

PSR-MS50 / PSR-MS55



Safety relays for monitoring non-equivalent signal generators

Data sheet
106170_en_02

© PHOENIX CONTACT 2016-10-28

1 Description

Intended Use

The safety relays are used to monitor two-channel, non-equivalent signal generators and to control actuators.

When the corresponding safety equipment is actuated, the safety relays initiate the safe state.

The safety relays interrupt circuits in a safety-related way.

Possible signal generators

- Solenoid switch

Contact type

- 1 undelayed enabling current path
- 1 digital signal output

The enabling current path drops out without delay according to stop category 0 (EN 60204-1).

When the enabling current path is open, the signal output is active.

The signal output transmits non-safety-related status information.

Control

- Two-channel, non-equivalent
- Automatic start (PSR-MS50 only)
- Manual, monitored start (PSR-MS55 only)

Achievable safety integrity

- Suitable up to category 4, PL e (EN ISO 13849-1), SILCL 3 (EN 62061)

Additional features

- Fixed screw connection
- 6.8 mm housing width

Approvals



WARNING: Risk of electric shock

Observe the safety regulations and installation notes in the corresponding section.



Make sure you always use the latest documentation.

It can be downloaded from the product at phoenixcontact.net/products.



This document is valid for the products listed in the "Ordering data".

This document meets the same requirements as the original operating instructions with respect to the contents.

2	Table of contents	
1	Description	1
2	Table of contents	2
3	Ordering data	3
4	Technical data	3
5	Safety regulations and installation notes.....	7
6	Function description	9
7	Function and time diagrams	9
8	Basic circuit diagram	10
9	Derating.....	10
10	Load curve.....	10
11	Operating and indication elements	11
12	Mounting and removing	12
13	Wiring	12
14	Startup.....	13
15	Calculating the power dissipation	13
16	Diagnostics.....	14
17	Application examples	16
18	Attachment	17

3 Ordering data

Description	Type	Order No.	Pcs./Pkt.
Safety relay for monitoring non-equivalent signal generators up to SILCL 3, Cat. 4, PL e, 2-channel, non-equivalent operation, automatic start, 1 enabling current path, $U_S = 24$ V DC, fixed screw terminal block	PSR-MS50-1NO-1DO-24DC-SC	2904956	1
Safety relay for monitoring non-equivalent signal generators up to SILCL 3, Cat. 4, PL e, 2-channel, non-equivalent operation, manual, monitored start, 1 enabling current path, $U_S = 24$ V DC, fixed screw terminal block	PSR-MS55-1NO-1DO-24DC-SC	2904957	1

4 Technical data

Hardware/firmware version	
HW/FW	≥ 00/--
The technical data and safety characteristics are valid as of the specified HW/FW version.	
Input data	
Rated control circuit supply voltage U_S	24 V DC -15 % / +10 %
Rated control supply current I_S	typ. 42 mA
Input voltage range "0" signal	0 V DC ... 5 V DC (for safe Off; at S12)
Input current range "0" signal	0 mA ... 2 mA (for safe Off; at S12)
Inrush current	4.5 A ($\Delta t = 120 \mu s$ at U_S) < 20 mA (with U_S/I_x to S12) < 10 mA (with U_S/I_x at the start circuit) < 20 mA (with U_S/I_x to S13)
Current consumption	< 5 mA (with U_S/I_x to S12) < 5 mA (with U_S/I_x to S13) < 10 mA (with U_S/I_x at the start circuit)
Power consumption at U_S	typ. 1 W
Voltage at input/start and feedback circuit	24 V DC -15 % / +10 %
Filter time	1 ms (at A1 in the event of voltage dips at U_S) max. 1.5 ms (at S12, S13; test pulse width) min. 7.5 ms (at S12, S13; test pulse rate) Test pulse rate = 5 x Test pulse width
Max. permissible overall conductor resistance (Input and reset circuit at U_S)	150 Ω
Typical response time at U_S	< 175 ms
Typical starting time with U_S	< 250 ms (when controlled via A1)
Typical release time with U_S	< 20 ms (when controlled via A1 or S12 and S13.)
Recovery time	< 500 ms
Maximum switching frequency	0.5 Hz

Input data	
Operating voltage display	1 x green LED
Status display	2 x green LEDs
Protective circuit	Surge protection Suppressor diode Protection against polarity reversal for rated control circuit supply voltage
Output data	
Contact type	1 enabling current path
Contact material	AgSnO ₂
Minimum switching voltage	12 V AC/DC
Maximum switching voltage	250 V AC/DC (Observe the load curve)
Limiting continuous current	6 A (observe derating)
Maximum inrush current	6 A
Inrush current, minimum	3 mA
Sq. Total current $I_{TH}^2 = I_1^2 + I_2^2 + \dots + I_N^2$	36 A ² (observe derating)
Switching capacity	min. 60 mW
Mechanical service life	10 x 10 ⁶ cycles
Output fuse	6 A gL/gG (N/O contact) 4 A gL/gG (for low-demand applications)
Alarm outputs	
Number of outputs	1 (digital, PNP)
Voltage	22 V DC (U _s - 2 V)
Current	max. 100 mA
Maximum inrush current	500 mA (Δt = 1 ms at U _s)
Short-circuit protection	no
General data	
Relay type	Electromechanical relay with forcibly guided contacts in accordance with IEC/EN 61810-3 (EN 50205)
Nominal operating mode	100% operating factor
Degree of protection	IP20
Min. degree of protection of inst. location	IP54
Mounting type	DIN rail mounting
Mounting position	vertical or horizontal
Assembly instructions	See derating curve
Dimensions (W/H/D)	6.8 x 93.1 x 102.5 mm
Type of housing	PBT yellow
Air clearances and creepage distances between the power circuits	according to DIN EN 50178
Rated insulation voltage	250 V AC

General data	
Rated surge voltage/insulation	Safe isolation, reinforced insulation 6 kV between input circuit and enabling current path Basic insulation 4 kV between all current paths and housing
Degree of pollution	2
Overvoltage category	III
Connection data	
Connection method	Screw connection
Conductor cross section, solid	0.2 mm ² ... 2.5 mm ²
Conductor cross section, flexible	0.2 mm ² ... 2.5 mm ²
Conductor cross section AWG/kcmil	26 ... 12
Stripping length	12 mm
Screw thread	M3
Ambient conditions	
Ambient temperature (operation)	-40 °C ... 60 °C (observe derating)
Ambient temperature (storage/transport)	-40 °C ... 85 °C
Max. permissible relative humidity (operation)	75 % (on average, 85% infrequently, non-condensing)
Max. permissible humidity (storage/transport)	75 % (on average, 85% infrequently, non-condensing)
Maximum altitude	≤ 2000 m (Above sea level)
Information on operating height	See the "Using PSR devices at altitudes greater than 2000 m above sea level" section
Shock	15g
Vibration (operation)	10 Hz ... 150 Hz, 2g
Conformance/Approvals	
Conformance	CE-compliant
The full EC Declaration of Conformity can be downloaded for the product at phoenixcontact.net/products .	
Approvals	
Safety data	
Stop category according to IEC 60204	0
Safety parameters for IEC 61508 - High demand	
SIL	3
PFH _D	1.5 x 10 ⁻⁹ (4 A DC13; 5 A AC15; 8760 switching cycles/year)
Demand rate	< 12 Months
Proof test interval	240 Months
Safety parameters for IEC 61508 - Low demand	
SIL	3
PFD _{avg}	1.47 x 10 ⁻⁴
Proof test interval	60 Months
Duration of use	240 Months

Safety characteristic data according to EN ISO 13849

Category	4
Performance level	e (4 A DC13; 5 A AC15; 8760 switching cycles/year)
Duration of use	240 Months

For applications in PL e, the required demand rate for the safety function is once per month.

Safety parameters for EN 62061

SILCL	3
-------	---

5 Safety regulations and installation notes



WARNING: Death, serious personal injury or damage to equipment

Depending on the application, incorrect handling of the device may pose serious risks for the user or cause damage to equipment.

- Observe all the safety notes and warning instructions provided in this chapter and elsewhere in this document.

General

- Observe the safety regulations of electrical engineering and industrial safety and liability associations.

Disregarding these safety regulations may result in death, serious personal injury or damage to equipment.



The device contains components that can be damaged or destroyed by electrostatic discharge.

- When handling the device, observe the necessary safety precautions against electrostatic discharge (ESD) according to EN 61340-5-1 and IEC 61340-5-1.

Power supply units for 24 V supply

- Only use power supply units with safe isolation and SELV/PELV according to EN 50178/VDE 0160.
- Provide external protection for the 24 V area.
- Make sure that the power supply unit is able to supply **four times** the nominal current of the external fuse, to ensure that it trips in the event of an error.

Startup, mounting, and modifications

Startup, mounting, modifications, and upgrades may only be carried out by an electrically skilled person.

- Before working on the device, disconnect the power.
- Carry out wiring according to the application. Refer to the "Application examples" section for this.

Reliable operation is only ensured if the device is installed in housing protected from dust and humidity.

- Install the device in housing protected from dust and humidity (min. IP54).

In operation

During operation, parts of electrical switching devices carry hazardous voltages.

- Protective covers must not be removed when operating electrical switching devices.

For emergency stop applications, automatic startup of the machine can pose serious risks for the user.

- The machine must be prevented from restarting automatically by a higher-level controller.

With the manual, monitored reset device, a machine start may not be triggered in accordance with EN ISO 13849-1.

Inductive loads can lead to welded relay contacts.

- Connect a suitable and effective protective circuit to inductive loads.
- Implement the protective circuit parallel to the load and not parallel to the switch contact.

Magnetic fields can influence the device. The magnetic field strength of the environment must not exceed 30 A/m.

- Do not use the device in the vicinity of strong magnetic fields (e.g., caused by transformers or magnetic iron).

Noise emission may occur when operating relay modules. Wireless reception may be disrupted in residential areas.

The device is a Class A product.

- Observe the requirements for noise emission for electrical and electronic equipment (EN 61000-6-4).
- Implement appropriate precautions against noise emission.

Faulty devices

The devices may be damaged following an error. Correct operation can no longer be ensured.

- In the event of an error, replace the device.

Only the manufacturer or their authorized representative may perform the following activities. Otherwise the warranty is invalidated.

- Repairs to the device
- Opening the housing

Taking out of service and disposal

- Dispose of the device in accordance with environmental regulations.
- Make sure that the device can never be reused.

6 Function description

6.1 Two-channel, non-equivalent sensor circuit

The two-channel sensor circuit has a non-equivalent design. A non-equivalent signal is expected and this is how the safety relay detects short circuits and cross-circuits in the sensor circuit.

6.2 Automatic start

PSR-MS50 only

The device starts automatically once channel 1 of the sensor circuit has been closed and channel 2 has been opened.

6.3 Manual, monitored start

PSR-MS55 only

When channel 1 of the sensor circuit is closed and channel 2 is open, the device starts once the start circuit has been closed and opened again by pressing and releasing the reset button.

A connected reset button is monitored.

6.4 Safe shutdown

When the corresponding safety equipment is actuated, the enabling current path opens without delay.

When the enabling current path is open, the device is in the safe state.

Signal output M1 is active.



Signal output M1 transmits non-safety-related status information. Feedback of signal output M1 to external basic devices for reasons of functional safety is therefore not required.

7 Function and time diagrams

7.1 Time diagram PSR-MS50

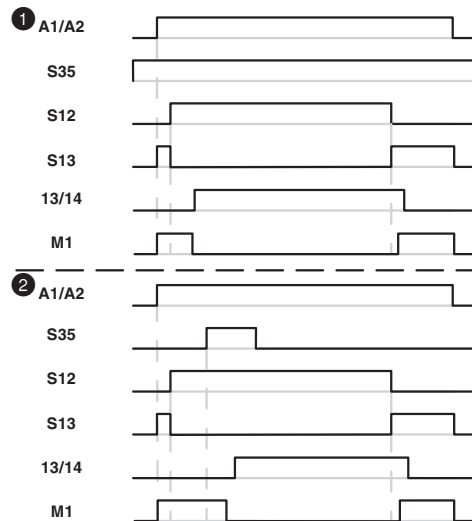

Figure 1 Time diagram PSR-MS50

7.2 Time diagram PSR-MS55

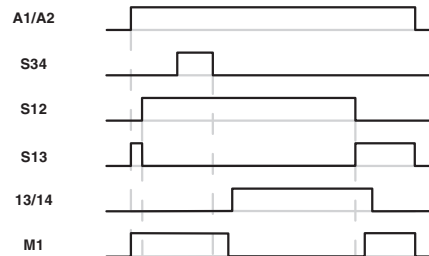

Figure 2 Time diagram PSR-MS55

Key:

- ① Automatic start
- ② Start via external signal at S35 which is not monitored
- A1/A2 Power supply
- S35 (PSR-MS50 only) Automatic start
- S34 (PSR-MS55 only) Manual, monitored start
- S12 Input sensor circuit (channel 1)
- S13 Input sensor circuit (channel 2)
- 13/14 Enabling current path, undelayed
- M1 Signal output (PNP), not security-relevant

8 Basic circuit diagram

8.1 Block diagram PSR-MS50

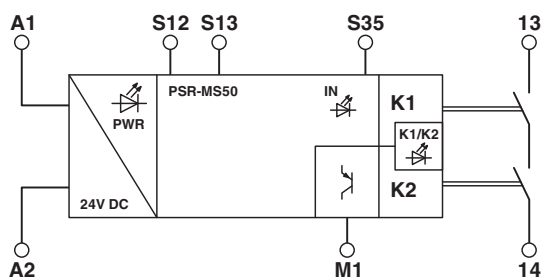

Figure 3 Block diagram PSR-MS50

8.2 Block diagram PSR-MS55

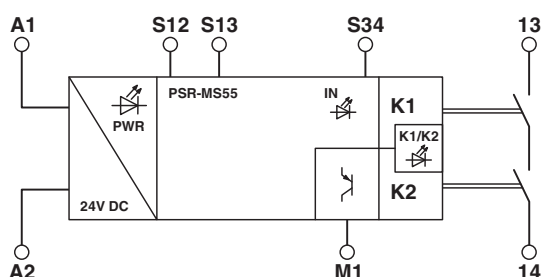

Figure 4 Block diagram PSR-MS55

Key:

A1	24 V DC power supply
A2	0 V power supply
S12	Input sensor circuit (channel 1)
S13	Input sensor circuit (channel 2)
S35 (PSR-MS50 only)	Automatic start
S34 (PSR-MS55 only)	Manual, monitored start
13/14	Enabling current path, undelayed
M1	Signal output (PNP), not security-relevant

9 Derating

9.1 Vertical or horizontal mounting position

The derating curve applies for the following conditions:

- Mounting on a vertical or horizontal DIN rail
- Devices mounted next to each other without spacing

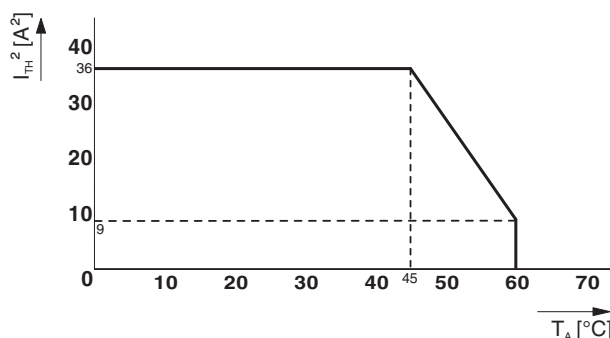

Figure 5 Derating curve - vertical or horizontal mounting position, without spacing

10 Load curve

10.1 Ohmic and inductive load

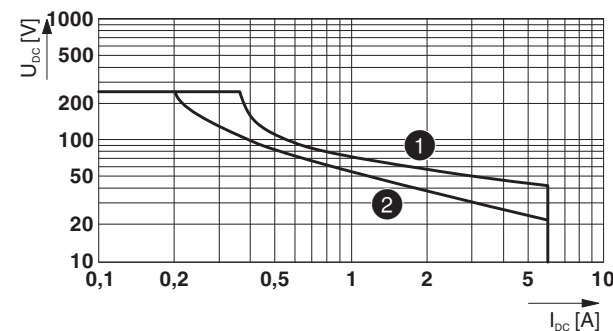

Figure 6 Relay load curve - ohmic and inductive load

Key:

- ① Ohmic load L/R = 0 ms
- ② Inductive load L/R = 40 ms

11 Operating and indication elements

11.1 Connection versions

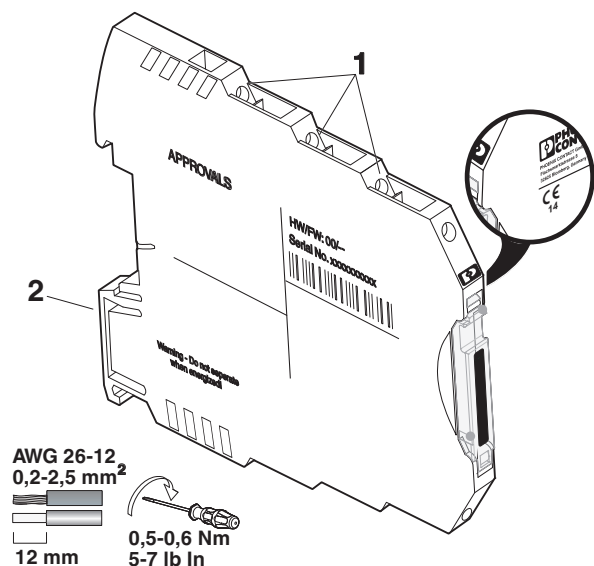

- 1 Fixed screw connection
- 2 Snap-on foot for DIN rail mounting



The year the device was constructed can be found underneath the CE designation on the housing.

Figure 7 Connection versions

11.2 Connection assignment

<table border="1" style="border-collapse: collapse; text-align: center;"> <tr><td>A</td><td>1</td></tr> <tr><td>A</td><td>2</td></tr> <tr><td>S</td><td>13</td></tr> <tr><td>S</td><td>12</td></tr> <tr><td colspan="2" style="text-align: center;">P</td></tr> <tr><td colspan="2" style="text-align: center;">PWR</td></tr> <tr><td colspan="2" style="text-align: center;">IN</td></tr> <tr><td colspan="2" style="text-align: center;">K1 K2</td></tr> <tr><td colspan="2" style="text-align: center;">MS 50</td></tr> <tr><td>S</td><td>35</td></tr> <tr><td>1</td><td>4</td></tr> <tr><td>1</td><td>3</td></tr> <tr><td>M</td><td>1</td></tr> </table>	A	1	A	2	S	13	S	12	P		PWR		IN		K1 K2		MS 50		S	35	1	4	1	3	M	1	<table border="1" style="border-collapse: collapse; text-align: center;"> <tr><td>A</td><td>1</td></tr> <tr><td>A</td><td>2</td></tr> <tr><td>S</td><td>13</td></tr> <tr><td>S</td><td>12</td></tr> <tr><td colspan="2" style="text-align: center;">P</td></tr> <tr><td colspan="2" style="text-align: center;">PWR</td></tr> <tr><td colspan="2" style="text-align: center;">IN</td></tr> <tr><td colspan="2" style="text-align: center;">K1 K2</td></tr> <tr><td colspan="2" style="text-align: center;">MS 55</td></tr> <tr><td>S</td><td>34</td></tr> <tr><td>1</td><td>4</td></tr> <tr><td>1</td><td>3</td></tr> <tr><td>M</td><td>1</td></tr> </table>	A	1	A	2	S	13	S	12	P		PWR		IN		K1 K2		MS 55		S	34	1	4	1	3	M	1	<p>A1 24 V DC power supply</p> <p>A2 0 V power supply</p> <p>S13 Input sensor circuit (channel 2)</p> <p>S12 Input sensor circuit (channel 1)</p> <p>PWR Power LED (green)</p> <p>IN Status indicator sensor circuit; LED (green)</p> <p>K1/K2 Status indicator safety circuit; LED (green)</p> <p>S35 (PSR-MS50 only) Automatic start</p> <p>S34 (PSR-MS55 only) Manual, monitored start</p> <p>13/14 Enabling current path, undelayed</p> <p>M1 Signal output (PNP), not security-relevant</p>
A	1																																																					
A	2																																																					
S	13																																																					
S	12																																																					
P																																																						
PWR																																																						
IN																																																						
K1 K2																																																						
MS 50																																																						
S	35																																																					
1	4																																																					
1	3																																																					
M	1																																																					
A	1																																																					
A	2																																																					
S	13																																																					
S	12																																																					
P																																																						
PWR																																																						
IN																																																						
K1 K2																																																						
MS 55																																																						
S	34																																																					
1	4																																																					
1	3																																																					
M	1																																																					

12 Mounting and removing

- Mount the device on a 35 mm DIN rail according to EN 60715.
- To remove the device, use a screwdriver to release the snap-on foot.

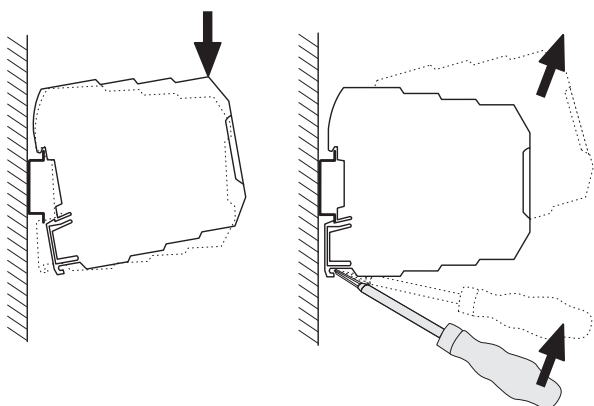

Figure 8 Mounting and removing

13 Wiring

- Connect the cables to the connection terminal blocks using a screwdriver.

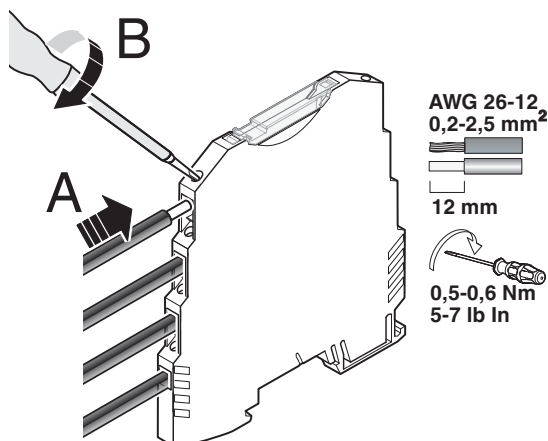

Figure 9 Connection of the cables



It is recommended that ferrules are used to connect stranded cables.



For compliance with UL approval, use copper wire that is approved up to 60°C/75°C.

13.1 Signal generator connection versions

- Connect suitable signal generators to S12/S13.

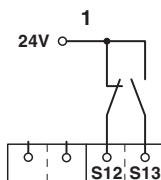

Figure 10 Signal generator connection versions

- 1 Two-channel, non-equivalent connection

13.2 Start and feedback circuit connection variants

Automatic start (PSR-MS50 only)

- Bridge the contacts A1/S35.

Manual, monitored start (PSR-MS55 only)

- Connect a reset button to contacts A1/S34. A connected reset button is monitored.

Start and feedback circuit

- Place the relevant N/C contacts in path A1/S34 or A1/S35 to monitor external contactors or extension devices with force-guided contacts.

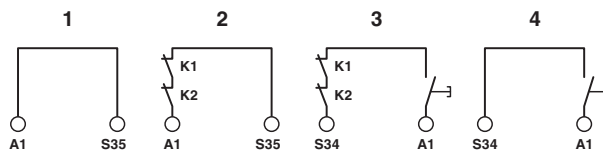

Figure 11 Start and feedback circuit connection variants

- 1 Automatic start
- 2 Automatic start with monitored contact extension
- 3 Manual, monitored start with monitored contact extension
- 4 Manual, monitored start

14 Startup

- Apply the rated control circuit supply voltage (24 V DC) at terminal blocks A1/A2.

The Power LED lights up.

- Close sensor circuit channel 1 (24 V/S12) and open channel 2 (24 V/S13).

The IN LED lights up.

Automatic start (PSR-MS50 only)

Enabling current path 13/14 closes.

The K1/K2 LED lights up.

Signal output M1 is not active.

Manual, monitored start (PSR-MS55 only)

- Press the reset button.
- Release the reset button.

Enabling current path 13/14 closes.

The K1/K2 LED lights up.

Signal output M1 is not active.

15 Calculating the power dissipation



The total power dissipation of the safety relay is based on the input power dissipation and the contact power dissipation for the same and for different load currents.

Input power dissipation

$$P_{\text{Input}} = U_B^2 / (U_S / I_S)$$

Contact power dissipation

With the same load currents:

$$P_{\text{Contact}} = n \cdot I_L^2 \cdot 50 \text{ m}\Omega$$

With different load currents:

$$P_{\text{Contact}} = (I_{L1}^2 + I_{L2}^2 + \dots + I_{Ln}^2) \cdot 50 \text{ m}\Omega$$

Total power dissipation

$$P_{\text{Total}} = P_{\text{Input}} + P_{\text{Contact}}$$

therefore

$$P_{\text{Total}} = U_B^2 / (U_S / I_S) + n \cdot I_L^2 \cdot 50 \text{ m}\Omega$$

or

$$P_{\text{Total}} = U_B^2 / (U_S / I_S) + (I_{L1}^2 + I_{L2}^2 + \dots + I_{Ln}^2) \cdot 50 \text{ m}\Omega$$

Key:

- P** Power dissipation in mW
- U_B** Applied operating voltage
- U_S** Rated control circuit supply voltage
- I_S** Rated control supply current
- n** Number of enabling current paths used
- I_L** Contact load current

16 Diagnostics

The following section describes the LED indicators for general states and error messages as well as possible causes and remedies.

Signal output M1 - not safety-related



Signal output M1 transmits non-safety-related status information. Feedback of signal output M1 to external basic devices for reasons of functional safety is therefore not required.

Function test/proof test

To verify the device function, proceed as follows:

- Demand the safety function by actuating the corresponding safety equipment.
- Check whether the safety function was executed correctly by switching the device on again.

If the device does not switch on again, the proof test failed.



WARNING: Loss of functional safety due to malfunction.

If the proof test contains errors, the device no longer functions correctly.

- Replace the device.

16.1 General states

PWR LED	IN LED	K1/K2 LED	State	Notes
ON	OFF	OFF	All relays are not activated. The sensor circuit is off.	Possible error see error messages
ON	ON	OFF	The sensor circuit is active. Relays K1 and K2 are ready to start and await reset/start command (S34 or S35).	
ON	ON	ON	The sensor circuit is active. All relays are picked up.	-

16.2 Error Messages

PWR LED	IN LED	K1/K2 LED	State	Possible cause	Corrective
ON	OFF	OFF	The sensor circuit is actively controlled, but no input LEDs are lit up.	Internal cross-circuit detection (via non-equivalence) is active: potential cross-circuit in the sensor circuit.	Check the sensor circuit/signal generator. Then perform a function test.
ON	ON	OFF	The sensor circuit is active. The reset/start circuit (S34 or S35) is/was activated. The safety circuit (K1 and K2) is not picking up.	External error: the readback contact (external actuator) is open in the reset circuit. Internal error: 1. The diagnostic contact is not working correctly. 2. An N/O contact is welded.	External error: check the actuator. Internal error: perform a power down reset with subsequent function test. If the error occurs again after the function test, replace the device.
ON	ON	OFF	The sensor circuit is active. The reset/start circuit (S34 or S35) is/was activated. The safety circuit (K1 and K2) is not picking up.	Error in the sensor circuit.	Check the sensor circuit. Then perform a function test. If the error occurs again after the function test, replace the device.
ON	ON	OFF	The sensor circuit is active. The reset/start circuit (S34) is/was activated. The safety circuit (K1 and K2) is not picking up.	Error during manual reset S34 (stuck-at at the input).	Remove the error in the reset/start circuit. Then perform a function test.
OFF	OFF	OFF	The sensor circuit is active.	1. No supply voltage at A1/A 2. Over- or undervoltage at A1	Check the supply voltage.

17 Application examples

Applications with the PSR-MS50

17.1 Magnetic switch monitoring/automatic start

- Two-channel, non-equivalent magnetic switch monitoring
- Automatic start
- Monitoring of external, force-guided contactors
- Suitable up to category 4, PL e (EN ISO 13849-1), SIL 3 (EN 62061), if cross-circuits in the control to the actuator can be ruled out



Cross-circuits in the cable installation can be excluded if the safety relay and external contactors K1 and K2 are located in the same electrical installation space.

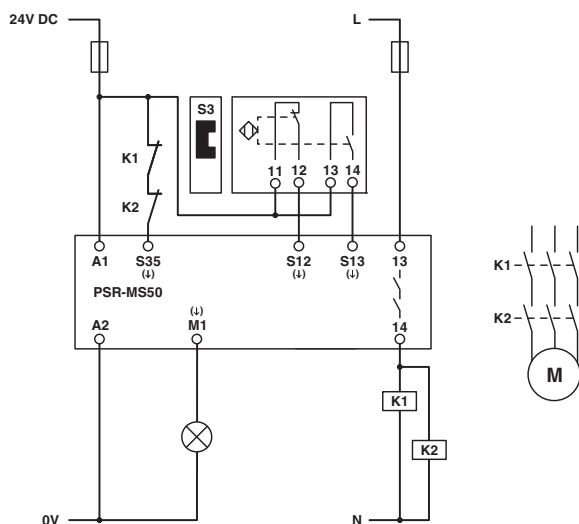

Figure 12 Magnetic switch monitoring/automatic start

Key:

- S3** Solenoid switch
- K1/K2** Force-guided contactors

Applications with the PSR-MS55

17.2 Magnetic switch monitoring/manual, monitored start

- Two-channel, non-equivalent magnetic switch monitoring
- Manual, monitored start
- Monitoring of external, force-guided contactors
- Suitable up to category 4, PL e (EN ISO 13849-1), SIL 3 (EN 62061), if cross-circuits in the control to the actuator can be ruled out



Cross-circuits in the cable installation can be excluded if the safety relay and external contactors K1 and K2 are located in the same electrical installation space.

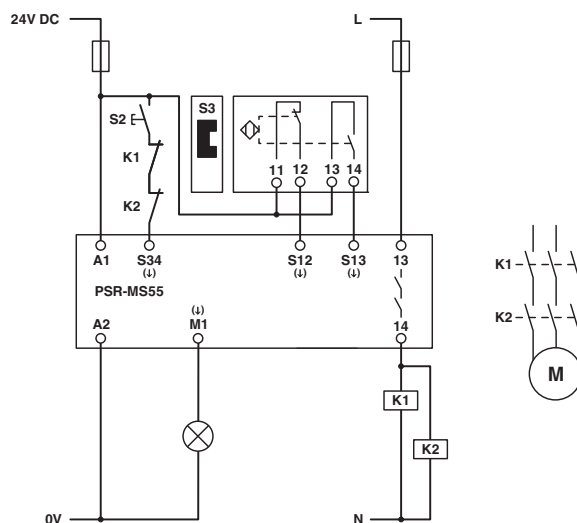

Figure 13 Magnetic switch monitoring/manual, monitored start

Key:

- S3** Solenoid switch
- S2** Manual reset device
- K1/K2** Force-guided contactors

18 Attachment

18.1 Using PSR devices at altitudes greater than 2000 m above sea level



The following section describes the special conditions for using PSR devices at altitudes greater than 2000 m above sea level. Observe the relevant device-specific data (technical data, derating, etc.) according to the product documentation for the individual device.

Using the device at altitudes **greater than 2000 m above sea level up to max. 4500 m above sea level** is possible under the following conditions:

1. Limit the rated control circuit supply voltage (U_S) in accordance with the table below. Observe the technical data for the device.

U_S according to the technical data for the device	U_S when used at altitudes greater than 2000 m above sea level
< 150 V AC/DC	U_S according to the technical data for the device still valid
> 150 V AC/DC	Limited to max. 150 V AC/DC

2. Limit the maximum switching voltage in accordance with the table below. Observe the technical data for the device.

Max. switching voltage according to the technical data for the device	Max. switching voltage when used at altitudes greater than 2000 m above sea level
< 150 V AC/DC	Max. switching voltage according to the technical data for the device still valid
> 150 V AC/DC	Limited to max. 150 V AC/DC

3. Reduce the maximum ambient temperature for operation by the corresponding factor in accordance with the table below.
4. If derating is specified, offset all the points of the derating curve by the corresponding factor in accordance with the table below.

Altitude above sea level	Temperature derating factor
2000 m	1
2500 m	0.953
3000 m	0.906
3500 m	0.859
4000 m	0.813
4500 m	0.766

Example calculation for 3000 m



The following calculation and the illustrated derating curve are provided as examples. Perform the actual calculation and offset the derating curve for the device used according to the technical data and the "Derating" section.

$$27\text{ °C} \cdot 0.906 \approx 24\text{ °C}$$

$$55\text{ °C} \cdot 0.906 \approx 49\text{ °C}$$

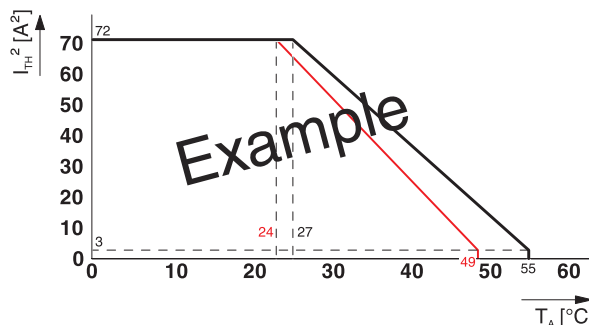

Figure 14 Example of a suspended derating curve (red)

18.2 Revision history

Version	Date	Contents
00	2014-12-03	First publication
01	2015-03-05	Reverse polarity protection extended; relay type extended; dimensions updated; load curve extended
02	2016-10-14	New edition of the data sheet: layout and structure revised; input voltage range and input current for "0" signal extended; output data (min. switching voltage) adjusted; relay type modified; note added regarding the protection of the 24 V area; inductive load curve extended; connection reset in Figure 11 adjusted; section on use at altitudes greater than 2000 m above sea level extended; information added regarding M1 = not safety-related



SCATTERGOOD & JOHNSON LTD

ELECTRICAL ENGINEERING & FLUID CONTROL DISTRIBUTORS

Est.1899

At Scattergood & Johnson Ltd, we pride ourselves on being a technical distributor to specialist industries.

Working with a range of quality product suppliers across a number of specialist markets, we are not your average 'box shifter' - we are your technical and supply chain partner.

We fully support every product we sell - for free! Our internal team and external sales engineers can answer any product or application question, no matter the complexity.

Backing up this technical ability is a range of 50,000+ products available from stock for nationwide next day delivery (same day if required!), or you can collect what you need from any of our trade counters around the UK.

Select your specialist interest below to learn more about how we can help.



Online, In Branch and On the Road - Scattergood & Johnson Ltd, there when you need us.

www.scatts.co.uk