

PSR-MS60



Safety relay for emergency stop, safety door and light grid monitoring

Data sheet
106171_en_03

© PHOENIX CONTACT 2016-10-28

1 Description

Intended Use

The safety relay is used to monitor single or two-channel signal generators and to control actuators.

When the sensor circuit is interrupted, the safety relay initiates the safe state.

The safety relay interrupts circuits in a safety-related way.

Possible signal generators

- Emergency stop button
- Door locking mechanisms
- Light grids

Contact type

- 2 undelayed single-channel enabling current paths

The enabling current paths drop out without delay according to stop category 0 (EN 60204-1).

Control

- Single or two channel
- Automatic start

Achievable safety integrity

- Suitable up to category 4, PL e (EN ISO 13849-1), SILCL 3 (EN 62061)

Additional features

- Fixed screw connection
- 6.8 mm housing width

Approvals



WARNING: Risk of electric shock

Observe the safety regulations and installation notes in the corresponding section.



Make sure you always use the latest documentation.

It can be downloaded from the product at phoenixcontact.net/products.



This document is valid for the products listed in the "Ordering data".

This document meets the same requirements as the original operating instructions with respect to the contents.

2	Table of contents	
1	Description	1
2	Table of contents	2
3	Ordering data	3
4	Technical data	3
5	Safety regulations and installation notes.....	6
6	Function description	8
	6.1 Single-channel sensor circuit	8
	6.2 Two-channel sensor circuit	8
	6.3 Automatic start.....	8
	6.4 Safe shutdown	8
7	Function and time diagrams	8
	7.1 Time diagram for automatic start	8
8	Basic circuit diagram	9
9	Derating.....	9
	9.1 Vertical or horizontal mounting position	9
10	Load curve.....	9
	10.1 Ohmic and inductive load	9
11	Operating and indication elements	10
	11.1 Connection versions	10
	11.2 Connection assignment.....	10
12	Mounting and removing	11
13	Wiring	11
	13.1 Signal generator connection versions	11
14	Startup.....	11
15	Calculating the power dissipation	12
16	Diagnostics.....	13
	16.1 General states	13
	16.2 Error Messages.....	13
17	Application examples	14
	17.1 Light grid monitoring/automatic start	14
	17.2 Two-channel control via LPSDO module	14
	17.3 Single-channel control via failsafe controller	15
18	Attachment	16
	18.1 Using PSR devices at altitudes greater than 2000 m above sea level.....	16
	18.2 Revision history.....	17

3 Ordering data

Description	Type	Order No.	Pcs./Pkt.
Safety relay for emergency stop, safety doors, and light grids up to SILCL 3, Cat. 4, PL e, 1 or 2-channel operation, automatic start, 2 enabling current paths (1-channel), $U_S = 24 \text{ V DC}$, fixed screw terminal block	PSR-MS60-2NO-24DC-SC	2904958	1

4 Technical data

Hardware/firmware version	
HW/FW	≥ 00/--
The technical data and safety characteristics are valid as of the specified HW/FW version.	
Input data	
Rated control circuit supply voltage U_S	24 V DC -15 % / +10 %
Rated control supply current I_S	typ. 40 mA
Input voltage range "0" signal	0 V DC ... 5 V DC (for safe Off; at S12 and S22)
Input current range "0" signal	0 mA ... 2 mA (for safe Off; at S12 and S22)
Inrush current	4.5 A ($\Delta t = 120 \mu\text{s}$ at U_S) < 20 mA (with U_S/I_x to S12) < 20 mA (with U_S/I_x to S22)
Current consumption	< 5 mA (with U_S/I_x to S12) < 5 mA (with U_S/I_x to S22)
Power consumption at U_S	typ. 0.96 W
Voltage at input/start and feedback circuit	24 V DC -15 % / +10 %
Filter time	1 ms (at A1 in the event of voltage dips at U_S) max. 1.5 ms (Test pulse duration) min. 7.5 ms (Test pulse rate) Test pulse rate = 5 x Test pulse width
Max. permissible overall conductor resistance (Input and reset circuit at U_S)	150 Ω
Typical response time at U_S	< 175 ms
Typical starting time with U_S	< 250 ms (when controlled via A1)
Typical release time with U_S	< 20 ms (when controlled via A1 or S12 and S22.)
Recovery time	< 500 ms
Maximum switching frequency	0.5 Hz
Operating voltage display	1 x green LED
Status display	2 x green LEDs
Protective circuit	Surge protection Suppressor diode Protection against polarity reversal for rated control circuit supply voltage

Output data	
Contact type	2 enabling current paths
Contact material	AgSnO ₂
Minimum switching voltage	12 V AC/DC
Maximum switching voltage	250 V AC/DC (Observe the load curve)
Limiting continuous current	6 A (observe derating)
Maximum inrush current	6 A
Inrush current, minimum	3 mA
Sq. Total current $I_{TH}^2 = I_1^2 + I_2^2 + \dots + I_N^2$	72 A ² (observe derating)
Switching capacity	min. 60 mW
Mechanical service life	10 x 10 ⁶ cycles
Output fuse	6 A gL/gG (N/O contact) 4 A gL/gG (for low-demand applications)
General data	
Relay type	Electromechanical relay with forcibly guided contacts in accordance with IEC/EN 61810-3 (EN 50205)
Nominal operating mode	100% operating factor
Degree of protection	IP20
Min. degree of protection of inst. location	IP54
Mounting type	DIN rail mounting
Mounting position	vertical or horizontal
Assembly instructions	See derating curve
Dimensions (W/H/D)	6.8 x 93.1 x 102.5 mm
Type of housing	PBT yellow
Air clearances and creepage distances between the power circuits	according to DIN EN 50178
Rated insulation voltage	250 V AC
Rated surge voltage/insulation	Safe isolation, reinforced insulation 6 kV between input circuit and enabling current path (13/14) and enabling current path (23/24) Basic insulation 4 kV between all current paths and housing
Degree of pollution	2
Overvoltage category	III
Connection data	
Connection method	Screw connection
Conductor cross section, solid	0.2 mm ² ... 2.5 mm ²
Conductor cross section, flexible	0.2 mm ² ... 2.5 mm ²
Conductor cross section AWG/kcmil	26 ... 12
Stripping length	12 mm
Screw thread	M3

Ambient conditions	
Ambient temperature (operation)	-40 °C ... 55 °C (observe derating)
Ambient temperature (storage/transport)	-40 °C ... 85 °C
Max. permissible relative humidity (operation)	75 % (on average, 85% infrequently, non-condensing)
Max. permissible humidity (storage/transport)	75 % (on average, 85% infrequently, non-condensing)
Maximum altitude	≤ 2000 m (Above sea level)
Information on operating height	See the "Using PSR devices at altitudes greater than 2000 m above sea level" section
Shock	15g
Vibration (operation)	10 Hz ... 150 Hz, 2g

Conformance/Approvals	
Conformance	CE-compliant
The full EC Declaration of Conformity can be downloaded for the product at phoenixcontact.net/products .	
Approvals	

Safety data	
Stop category according to IEC 60204	0

Safety parameters for IEC 61508 - High demand	
SIL	3
PFH _D	1.5 x 10 ⁻⁹ (4 A DC13; 5 A AC15; 8760 switching cycles/year)
Demand rate	< 12 Months
Proof test interval	240 Months
Duration of use	240 Months

Safety parameters for IEC 61508 - Low demand	
SIL	3
PFD _{avg}	1.47 x 10 ⁻⁴
Proof test interval	60 Months
Duration of use	240 Months

Safety characteristic data according to EN ISO 13849	
Category	4
Performance level	e (4 A DC13; 5 A AC15; 8760 switching cycles/year)
Duration of use	240 Months
For applications in PL e, the required demand rate for the safety function is once per month.	

Safety parameters for EN 62061	
SILCL	3

5 Safety regulations and installation notes



WARNING: Death, serious personal injury or damage to equipment

Depending on the application, incorrect handling of the device may pose serious risks for the user or cause damage to equipment.

- Observe all the safety notes and warning instructions provided in this chapter and elsewhere in this document.

General

- Observe the safety regulations of electrical engineering and industrial safety and liability associations.

Disregarding these safety regulations may result in death, serious personal injury or damage to equipment.



The device contains components that can be damaged or destroyed by electrostatic discharge.

- When handling the device, observe the necessary safety precautions against electrostatic discharge (ESD) according to EN 61340-5-1 and IEC 61340-5-1.

Power supply units for 24 V supply

- Only use power supply units with safe isolation and SELV/PELV according to EN 50178/VDE 0160.
- Provide external protection for the 24 V area.
- Make sure that the power supply unit is able to supply **four times** the nominal current of the external fuse, to ensure that it trips in the event of an error.

Startup, mounting, and modifications

Startup, mounting, modifications, and upgrades may only be carried out by an electrically skilled person.

- Before working on the device, disconnect the power.
- Carry out wiring according to the application. Refer to the "Application examples" section for this.

Reliable operation is only ensured if the device is installed in housing protected from dust and humidity.

- Install the device in housing protected from dust and humidity (min. IP54).

In operation

During operation, parts of electrical switching devices carry hazardous voltages.

- Protective covers must not be removed when operating electrical switching devices.

For emergency stop applications, automatic startup of the machine can pose serious risks for the user.

- The machine must be prevented from restarting automatically by a higher-level controller.

With the manual, monitored reset device, a machine start may not be triggered in accordance with EN ISO 13849-1.

Inductive loads can lead to welded relay contacts.

- Connect a suitable and effective protective circuit to inductive loads.
- Implement the protective circuit parallel to the load and not parallel to the switch contact.

Magnetic fields can influence the device. The magnetic field strength of the environment must not exceed 30 A/m.

- Do not use the device in the vicinity of strong magnetic fields (e.g., caused by transformers or magnetic iron).

Noise emission may occur when operating relay modules. Wireless reception may be disrupted in residential areas.

The device is a Class A product.

- Observe the requirements for noise emission for electrical and electronic equipment (EN 61000-6-4).
- Implement appropriate precautions against noise emission.

Faulty devices

The devices may be damaged following an error. Correct operation can no longer be ensured.

- In the event of an error, replace the device.

Only the manufacturer or their authorized representative may perform the following activities. Otherwise the warranty is invalidated.

- Repairs to the device
- Opening the housing

Taking out of service and disposal

- Dispose of the device in accordance with environmental regulations.
- Make sure that the device can never be reused.

6 Function description

6.1 Single-channel sensor circuit

The sensor circuit is not designed with redundancy.

The safety relay does not detect short and cross-circuits in the sensor circuit.

6.2 Two-channel sensor circuit

The sensor circuit is designed with redundancy.

The safety relay does not detect short and cross-circuits in the sensor circuit.

External cross-circuit detection can be implemented by using a suitable signal generator.

6.3 Automatic start

The device starts automatically after the sensor circuit has been closed.

6.4 Safe shutdown

Channel 1 and channel 2 of the sensor circuit are assigned to the enabling current paths as follows:

- Channel 1: input S12 to enabling current path 13/14
- Channel 2: input S22 to enabling current path 23/24



See "Block diagram".

If a channel to the sensor circuit is opened (24 V/S12 or 24 V/S22) the corresponding enabling current path opens (13/14 or 23/24).

If only channel 1 (input S12) opens, only enabling current path 13/14 drops out.

If channel 2 (input S22) also opens, enabling current path 23/24 likewise drops out.

When the enabling current paths are open, the device is in the safe state.

7 Function and time diagrams

7.1 Time diagram for automatic start

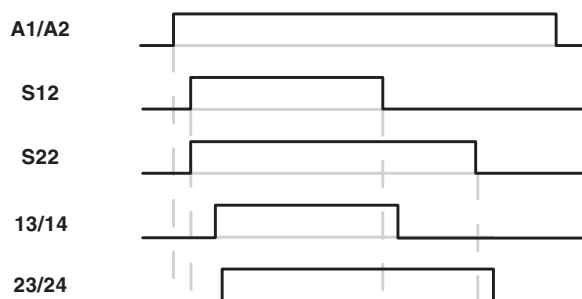

Figure 1 Time diagram

Key:

A1/A2	Power supply
S12	Input sensor circuit (channel 1)
S22	Input sensor circuit (channel 2)
13/14	Enabling current path (channel 1), undelayed
23/24	Enabling current path (channel 2), undelayed

8 Basic circuit diagram

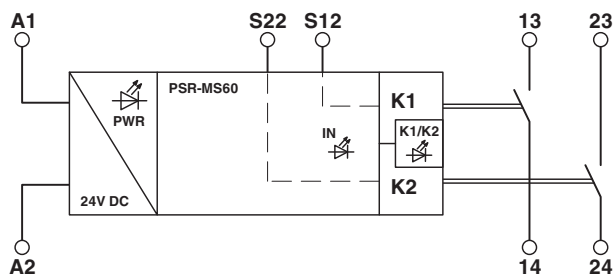

Figure 2 Block diagram

Key:

- A1** 24 V DC power supply
- A2** 0 V power supply
- S12** Input sensor circuit (channel 1)
- S22** Input sensor circuit (channel 2)
- 13/14** Enabling current path (channel 1), undelayed
- 23/24** Enabling current path (channel 2), undelayed



Observe the assignment of channel 1 and channel 2 of the sensor circuit to the enabling current paths:

- **Channel 1: input S12 to enabling current path 13/14**
- **Channel 2: input S22 to enabling current path 23/24**

See "Safe shutdown".

9 Derating

9.1 Vertical or horizontal mounting position

The derating curve applies for the following conditions:

- Mounting on a vertical or horizontal DIN rail
- Devices mounted next to each other without spacing

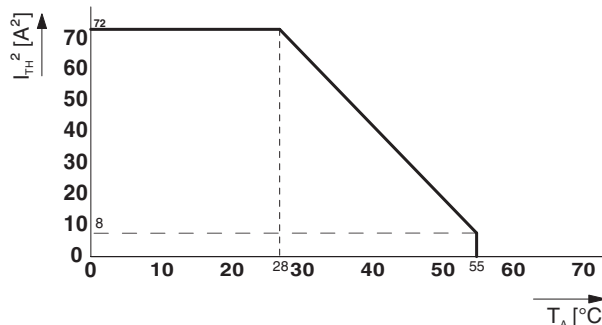

Figure 3 Derating curve - vertical or horizontal mounting position, without spacing

10 Load curve

10.1 Ohmic and inductive load

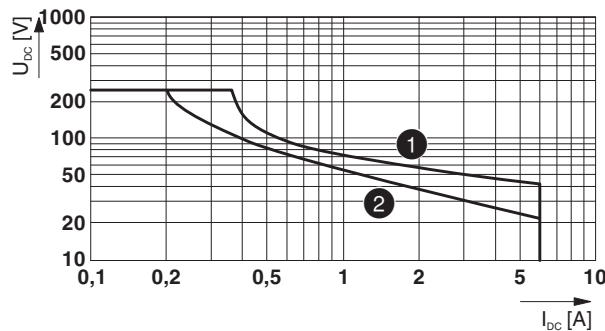

Figure 4 Relay load curve - ohmic and inductive load

Key:

- ① Ohmic load L/R = 0 ms
- ② Inductive load L/R = 40 ms

11 Operating and indication elements

11.1 Connection versions

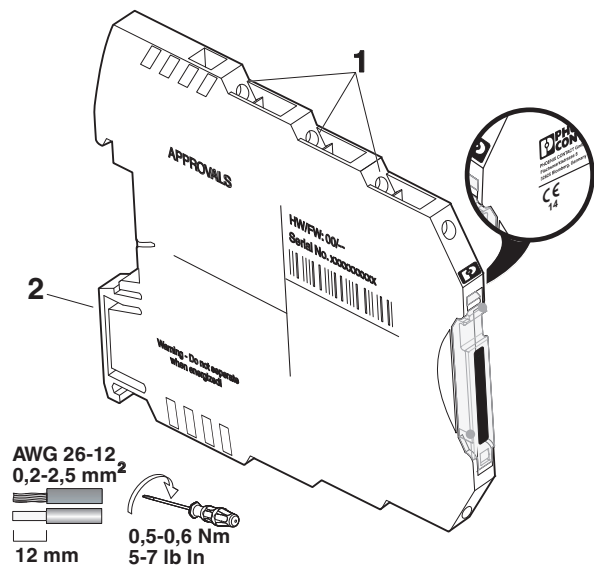

- 1 Fixed screw connection
- 2 Snap-on foot for DIN rail mounting



The year the device was constructed can be found underneath the CE designation on the housing.

Figure 5 Connection versions

11.2 Connection assignment

A 1	A1	24 V DC power supply
A 2	A2	0 V power supply
S 22	S22	Input sensor circuit (channel 2)
S 12	S12	Input sensor circuit (channel 1)
	PWR	Power LED (green)
	IN	Status indicator sensor circuit; LED (green)
	K1/K2	Status indicator safety circuit; LED (green)
MS 60		
2 4	23/24	Enabling current path (channel 2), undelayed
2 3	13/14	Enabling current path (channel 1), undelayed
1 4		
1 3		

12 Mounting and removing

- Mount the device on a 35 mm DIN rail according to EN 60715.
- To remove the device, use a screwdriver to release the snap-on foot.

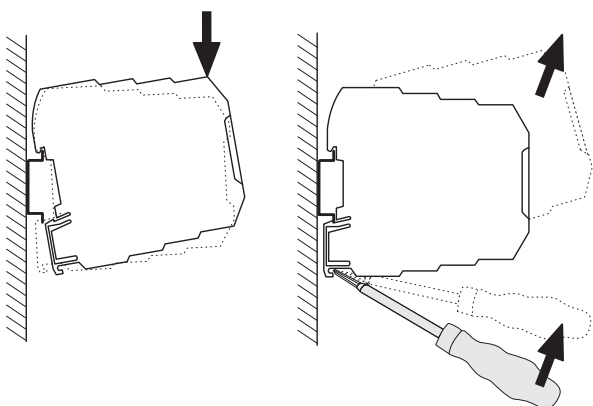

Figure 6 Mounting and removing

13 Wiring

- Connect the cables to the connection terminal blocks using a screwdriver.

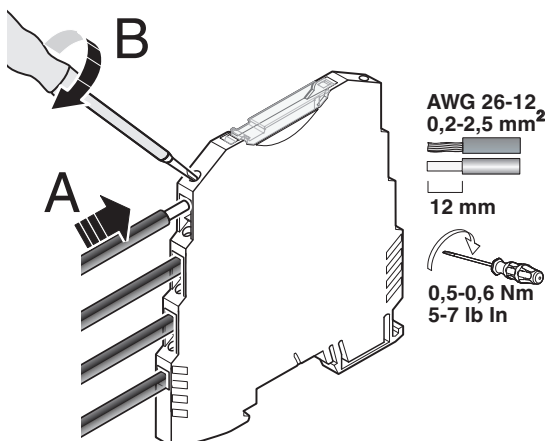

Figure 7 Connection of the cables



It is recommended that ferrules are used to connect stranded cables.



For compliance with UL approval, use copper wire that is approved up to 60°C/75°C.

13.1 Signal generator connection versions

- Connect suitable signal generators to S12/S22.

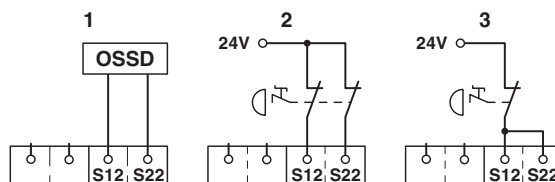

Figure 8 Signal generator connection versions

- 1 Two-channel connection with **external** cross-circuit monitoring
- 2 Two-channel connection without cross-circuit monitoring
- 3 Single-channel connection

14 Startup

- Apply the rated control circuit supply voltage (24 V DC) at terminal blocks A1/A2.

The Power LED lights up.

- Close the sensor circuit at 24 V/S12 and 24 V/S22 as per the wiring.

The IN LED lights up.



Single or two-channel sensor circuit: see "Signal generator connection versions".

The enabling current paths 13/14 and 23/24 close.

The K1/K2 LED lights up.

15 Calculating the power dissipation



The total power dissipation of the safety relay is based on the input power dissipation and the contact power dissipation for the same and for different load currents.

Input power dissipation

$$P_{\text{Input}} = U_B^2 / (U_S / I_S)$$

Contact power dissipation

With the same load currents:

$$P_{\text{Contact}} = n \cdot I_L^2 \cdot 25 \text{ m}\Omega$$

With different load currents:

$$P_{\text{Contact}} = (I_{L1}^2 + I_{L2}^2 + \dots + I_{Ln}^2) \cdot 25 \text{ m}\Omega$$

Total power dissipation

$$P_{\text{Total}} = P_{\text{Input}} + P_{\text{Contact}}$$

therefore

$$P_{\text{Total}} = U_B^2 / (U_S / I_S) + n \cdot I_L^2 \cdot 25 \text{ m}\Omega$$

or

$$P_{\text{Total}} = U_B^2 / (U_S / I_S) + (I_{L1}^2 + I_{L2}^2 + \dots + I_{Ln}^2) \cdot 25 \text{ m}\Omega$$

Key:

- P** Power dissipation in mW
- U_B** Applied operating voltage
- U_S** Rated control circuit supply voltage
- I_S** Rated control supply current
- n** Number of enabling current paths used
- I_L** Contact load current

16 Diagnostics

The following section describes the LED indicators for general states and error messages as well as possible causes and remedies.

Function test/proof test

To verify the device function, proceed as follows:

- Demand the safety function by actuating the corresponding safety equipment.
- Check whether the safety function was executed correctly by switching the device on again.

If the device does not switch on again, the proof test failed.



WARNING: Loss of functional safety due to malfunction.

If the proof test contains errors, the device no longer functions correctly.

- Replace the device.

16.1 General states

PWR LED	IN LED	K1/K2 LED	State	Notes
ON	OFF	OFF	All relays are not activated. The sensor circuit is off.	Possible error see error messages
ON	ON	ON	The sensor circuit is active. All relays are picked up.	-

16.2 Error Messages

PWR LED	IN LED	K1/K2 LED	State	Possible cause	Corrective
ON	OFF	OFF	The sensor circuit is actively controlled, but no input LEDs are lit up.	Interrupt in the sensor circuit or faulty signal generator.	Check the sensor circuit/signal generator. Then perform a function test.
ON	ON	OFF	The sensor circuit is active. The safety circuit (K1 and K2) is not picking up.	Internal error: 1. The diagnostic contact is not working correctly. 2. An N/O contact is welded.	Internal error: perform a power down reset with subsequent function test. If the error occurs again after the function test, replace the device.
ON	ON	OFF	The sensor circuit is active. The safety circuit (K1 and K2) is not picking up.	Error in the sensor circuit.	Check the sensor circuit. Then perform a function test. If the error occurs again after the function test, replace the device.
OFF	OFF	OFF	The sensor circuit is active.	1. No supply voltage at A1/A 2. Over- or undervoltage at A1	Check the supply voltage.

17 Application examples

17.1 Light grid monitoring/automatic start

- Two-channel light grid monitoring
- Automatic start
- Monitoring of external, force-guided contactors
- Suitable up to category 4, PL e (EN ISO 13849-1), SIL 3 (EN 62061)

WARNING: Loss of functional safety!
Make sure that the signal generator and the safety relay have the same ground potential.

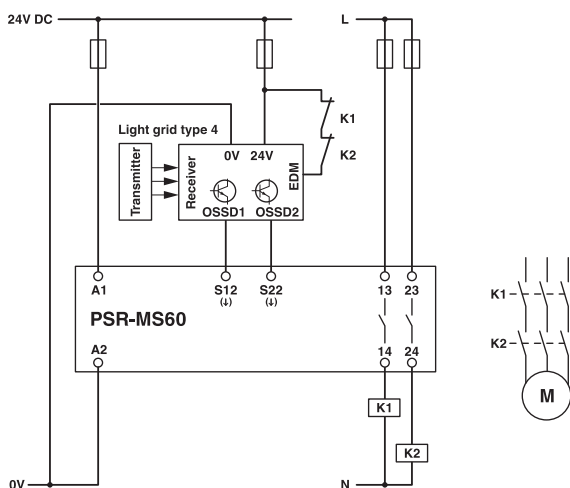

Figure 9 Light grid monitoring/automatic start

Key:

- EDM** Input supply for start and feedback circuit, Monitoring of external contacts
- K1/K2** Force-guided contactors

17.2 Two-channel control via LPSDO module

- Two-channel control
- Cross-circuit detection by means of LPSDO module
- Monitoring of external, force-guided contactors
- Automatic start
- Suitable up to category 4, PL e (EN ISO 13849-1), SIL 3 (EN 62061)

WARNING: Loss of functional safety!
Make sure that the signal generator and the safety relay have the same ground potential.

WARNING: Loss of functional safety!
The switch-on pulses sent by the controller (light test) can lead to brief, unwanted activation of the safety relay.

- Deactivate the light pulses/light tests, unless they are safety-related.

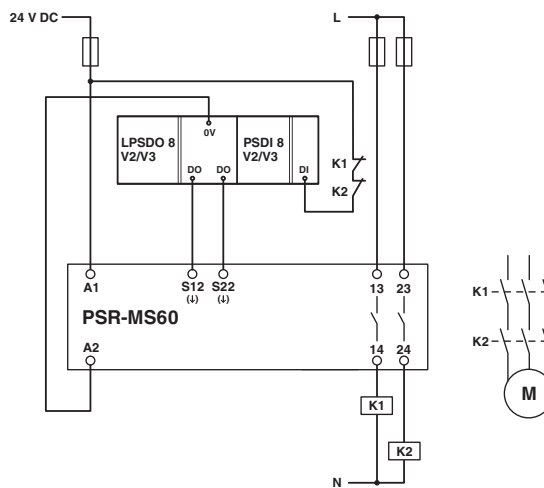

Figure 10 Two-channel control via LPSDO module

Key:

- DO** Digital output
- DI** Digital input
- K1/K2** Force-guided contactors

17.3 Single-channel control via failsafe controller

- Single-channel control
- Automatic start
- Monitoring of external, force-guided contactors
- Suitable up to category 4, PL e (EN ISO 13849-1), SIL 3 (EN 62061), if the failsafe controller meets PL e, SIL 3 and cross-circuits can be ruled out



WARNING: Loss of functional safety!

Make sure that the signal generator and the safety relay have the same ground potential.



WARNING: Loss of functional safety!

The switch-on pulses sent by the controller (light test) can lead to brief, unwanted activation of the safety relay.

- Deactivate the light pulses/light tests, unless they are safety-related.

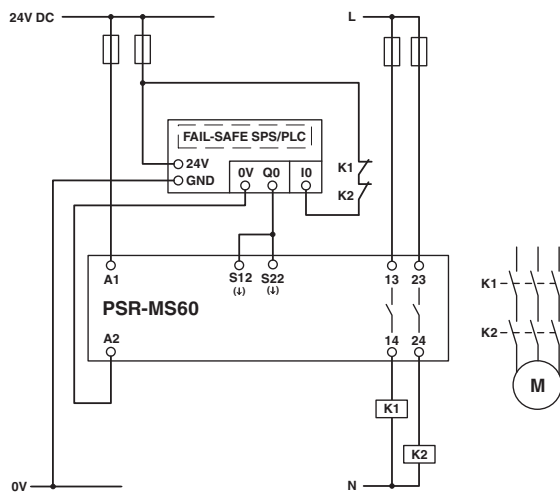

Figure 11 Single-channel control via failsafe PLC

Key:

- Q0** Digital output
IO Digital input
K1/K2 Force-guided contactors

18 Attachment

18.1 Using PSR devices at altitudes greater than 2000 m above sea level



The following section describes the special conditions for using PSR devices at altitudes greater than 2000 m above sea level. Observe the relevant device-specific data (technical data, derating, etc.) according to the product documentation for the individual device.

Using the device at altitudes **greater than 2000 m above sea level up to max. 4500 m above sea level** is possible under the following conditions:

1. Limit the rated control circuit supply voltage (U_S) in accordance with the table below. Observe the technical data for the device.

U_S according to the technical data for the device	U_S when used at altitudes greater than 2000 m above sea level
< 150 V AC/DC	U_S according to the technical data for the device still valid
> 150 V AC/DC	Limited to max. 150 V AC/DC

2. Limit the maximum switching voltage in accordance with the table below. Observe the technical data for the device.

Max. switching voltage according to the technical data for the device	Max. switching voltage when used at altitudes greater than 2000 m above sea level
< 150 V AC/DC	Max. switching voltage according to the technical data for the device still valid
> 150 V AC/DC	Limited to max. 150 V AC/DC

3. Reduce the maximum ambient temperature for operation by the corresponding factor in accordance with the table below.
4. If derating is specified, offset all the points of the derating curve by the corresponding factor in accordance with the table below.

Altitude above sea level	Temperature derating factor
2000 m	1
2500 m	0.953
3000 m	0.906
3500 m	0.859
4000 m	0.813
4500 m	0.766

Example calculation for 3000 m



The following calculation and the illustrated derating curve are provided as examples. Perform the actual calculation and offset the derating curve for the device used according to the technical data and the "Derating" section.

$$27\text{ °C} \cdot 0.906 \approx 24\text{ °C}$$

$$55\text{ °C} \cdot 0.906 \approx 49\text{ °C}$$

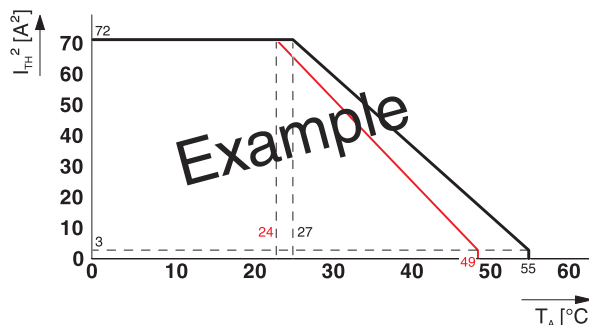

Figure 12 Example of a suspended derating curve (red)

18.2 Revision history

Version	Date	Contents
00	2014-12-03	First publication
01	2015-03-05	Reverse polarity protection extended; relay type extended; dimensions updated; load curve extended
02	2015-08-21	Input voltage range "0" signal supplemented; relay type changed; application examples and notes on examples revised
03	2016-09-30	New edition of the data sheet: layout and structure revised; input current for "0" signal extended; output data (min. switching voltage, min. switching capacity) adjusted; note added regarding the protection of the 24 V area; inductive load curve extended; section on use at altitudes greater than 2000 m above sea level extended



SCATTERGOOD & JOHNSON LTD

ELECTRICAL ENGINEERING & FLUID CONTROL DISTRIBUTORS

Est.1899

At Scattergood & Johnson Ltd, we pride ourselves on being a technical distributor to specialist industries.

Working with a range of quality product suppliers across a number of specialist markets, we are not your average 'box shifter' - we are your technical and supply chain partner.

We fully support every product we sell - for free! Our internal team and external sales engineers can answer any product or application question, no matter the complexity.

Backing up this technical ability is a range of 50,000+ products available from stock for nationwide next day delivery (same day if required!), or you can collect what you need from any of our trade counters around the UK.

Select your specialist interest below to learn more about how we can help.

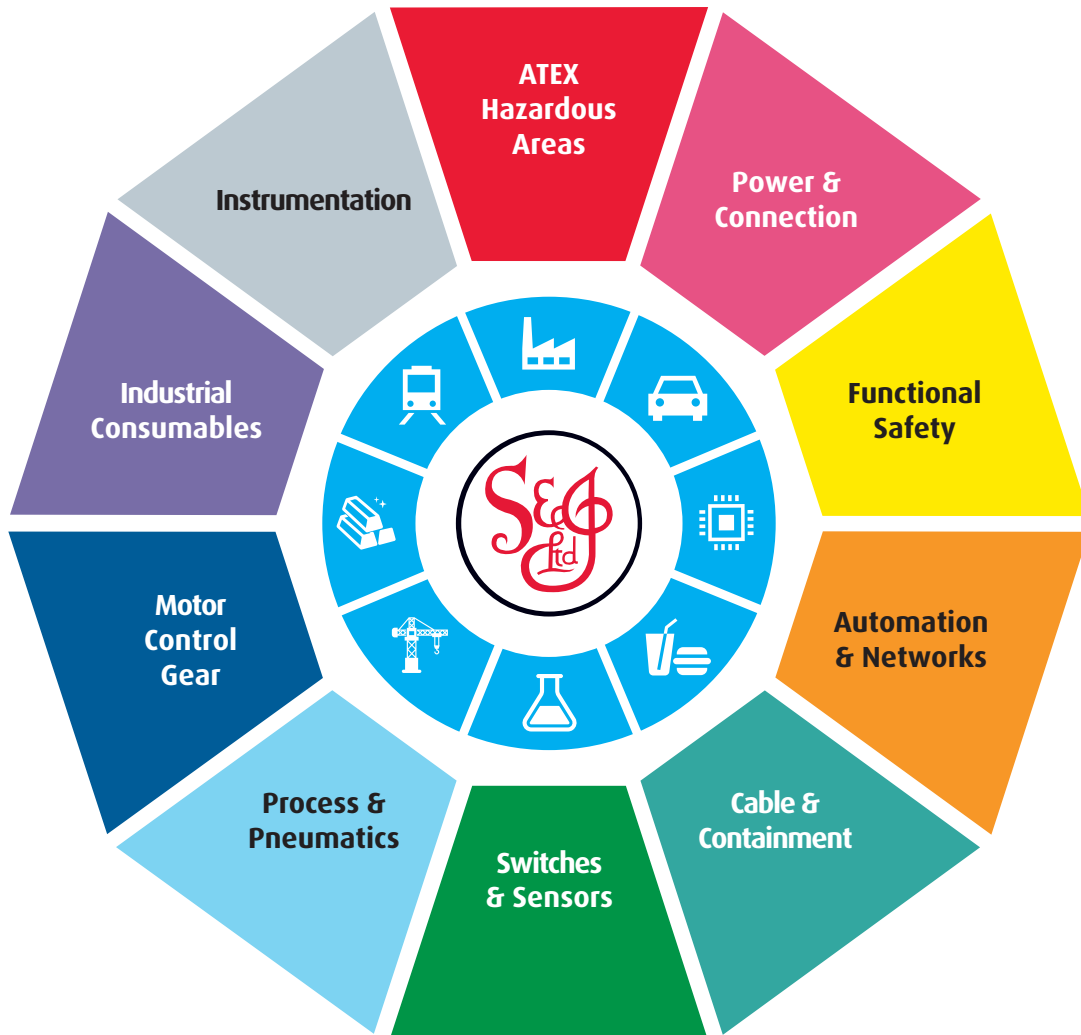

Online, In Branch and On the Road - Scattergood & Johnson Ltd, there when you need us.

www.scatts.co.uk