

EMD-SL-PH-690

Electronic monitoring relay for undervoltage, phase sequence, and phase failure monitoring



Data sheet
106037_en_00

© PHOENIX CONTACT - 2014-06-17

1 Description

Increasingly higher demands are being placed on safety and system availability – across all sectors. Processes are becoming more and more complex, not only in mechanical engineering and the chemical industry, but also in plant and automation technology. Demands on power engineering are also increasing constantly.

Error-free and therefore cost-effective operation can only be achieved through continuous monitoring of important network and system parameters. Electronic monitoring relays in the EMD series are available for a wide range of monitoring tasks to avoid the consequences of errors or to keep them within limits.

The operating states are indicated using colored LEDs, errors that may occur can be sent to a control system via a floating contact or can shut down a part of the system. Some device versions are equipped with startup and response delays in order to briefly tolerate measured values outside the set monitoring range.

Features

- Phase sequence monitoring
- Phase failure monitoring
- Undervoltage monitoring
- Adjustable response delay
- 2 PDT



WARNING: Risk of electric shock

Never carry out work when voltage is present.



Make sure you always use the latest documentation.
It can be downloaded from the product at phoenixcontact.net/products.

2 Ordering data

Description	Type	Order No.	Pcs. / Pkt.
Electronic monitoring relay for undervoltage, phase sequence, and phase failure monitoring	EMD-SL-PH-690	2905597	1

3 Technical data

Input data	
Input name	Measuring input
Measured value	AC sine (48 Hz ... 63 Hz)
Nominal input voltage U_N	690 V (3~ 208 V ... 690 V)
Input voltage range	177 V ... 794 V (3~)
Maximum input voltage	3~ 794 V
Setting range for response delay	0.1 s ... 10 s
Min setting range of the voltage threshold value	180 V AC
Max. setting range of the voltage threshold value	690 V AC
Function	Undervoltage , Phase sequence , Phase failure
Basic accuracy	≤ 3 % (of scale end value)
Setting accuracy	≤ 5 % (of scale end value)
Repeat accuracy	≤ 2 %
Asymmetry	25 %
Recovery time	> 500 ms
Output data	
Contact type	2 floating PDT contacts
Maximum switching voltage	400 V AC
Interrupting rating (ohmic load) max.	1250 VA (5 A/250 V AC at +55 °C) 150 VA (5 A/30 V DC at +55 °C) 75 VA (2.5 A/30 V DC at +70 °C)
Output fuse	5 A (fast-blow)
Supply	
Supply voltage	±15 % (= measuring voltage)
Frequency range	48 Hz ... 63 Hz
Nominal power consumption	2 VA (1.2 W)
General data	
Mains type	3-phase
Operating voltage display	Green LED
Status display	Yellow LED
Indication	Red LED
Mechanical service life	20 x 10 ⁶ cycles
Service life, electrical	2 x 10 ⁵ cycles
Switching frequency	≤ 6 (per minute at 1000 VA ohmic load)
Operating mode	100% operating factor
Degree of protection	IP40 (housing) / IP20 (connection terminal blocks)
Pollution degree	3 (IEC 60664-1)
Surge voltage category	III (IEC 60664-1)
Rated voltage	250 V (Output circuit (DIN EN 60947-5-1))
Mounting	on standard DIN rail NS 35 in accordance with EN 60715

General data [...]

Mounting position	any
Width	22.5 mm
Height	90 mm
Depth	113 mm
Type of housing	Polyamide PA, self-extinguishing
Color	green

Connection data

Conductor cross section, solid	0.5 mm ² ... 2.5 mm ²
Conductor cross section, stranded	0.5 mm ² ... 2.5 mm ²
Stripping length	8 mm
Connection method	Screw connection
Tightening torque	1 Nm

Ambient conditions

Ambient temperature (operation)	-25 °C ... 70 °C (C300) -25 °C ... 55 °C (B300)
Ambient temperature (storage/transport)	-25 °C ... 70 °C
Permissible humidity (operation)	15 % ... 85 %
Climatic class	3K3 (in acc. with EN 60721)

Conformance / approvals

Conformance	CE-compliant
UL, USA / Canada	UL 508 Listed

Conformance with EMC Directive 2004/108/EC

Noise immunity according to	EN 61326-1
Noise emission according to	EN 61326-1

Conformance with LV directive 2006/95/EC

Low voltage switchgear according to	EN 50178
-------------------------------------	----------

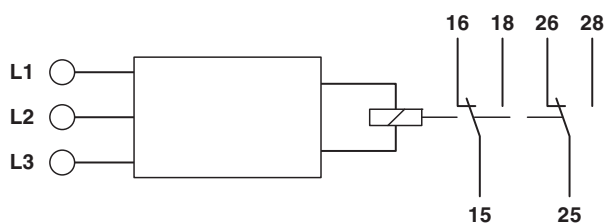
4 Block diagram**5 Safety notes****WARNING: Risk of electric shock**

Never carry out work when voltage is present.

6 Structure

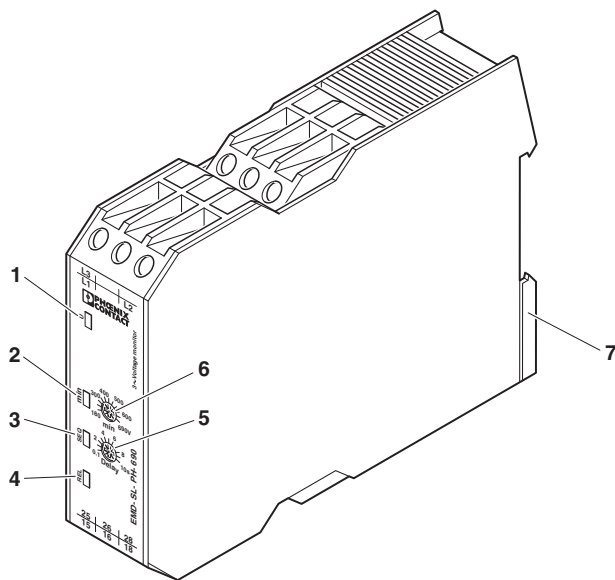

- 1 "U" LED: Supply voltage
- 2 "MIN" LED: Lower threshold value
- 3 "SEQ" LED: Phase failure/phase sequence
- 4 "REL" LED: Output relay
- 5 "Delay" potentiometer: response delay
- 6 "MIN" potentiometer: Lower threshold value
- 7 Universal snap-on foot for EN DIN rails

7 Installation



WARNING: Risk of electric shock

Never carry out work when voltage is present.

The module can be snapped onto all 35 mm DIN rails according to EN 60715.

8 Diagnostics

The LEDs indicate the following error states:

"U" LED (Green)

- LED ON: Supply voltage present

"MIN" LED (red)

- LED flashes: Set threshold value exceeded, set delay time is running
- LED ON: Set threshold value exceeded, delay time has elapsed

"SEQ" LED (Red)

- LED flashing: phase has failed, set delay time is running
- LED on: phase has failed, delay time has elapsed

"SEQ" LED (Red)

- LED ON: Phases connected incorrectly. LED lights up immediately, relay drops out without delay.

"REL" LED (Yellow)

- LED ON: Output relay has picked up
- LED OFF: Output relay has dropped out

9 Connection examples

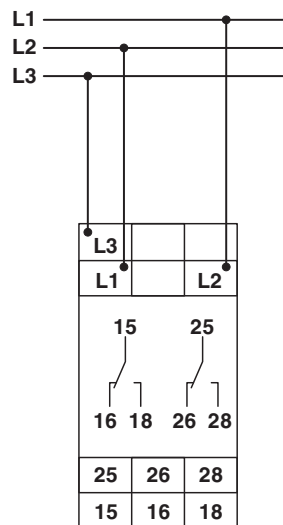
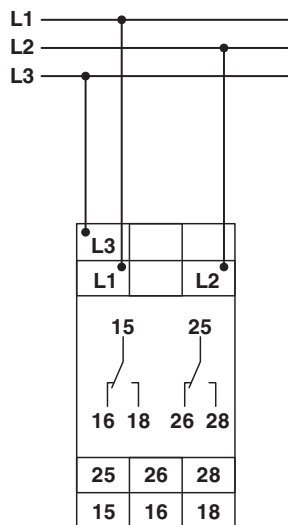

Correct phase connection: Output relay "R" picks up and yellow "REL" LED is ON

Modified phase sequence: Output relay "R" drops out and yellow "REL" LED is OFF

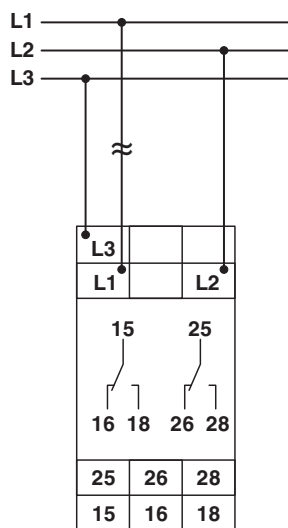

Phase failure: Output relay "R" drops out and yellow "REL" LED is OFF

10 Function

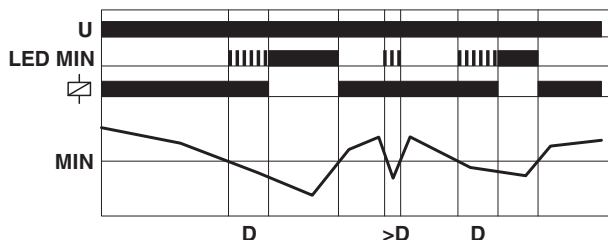

Undervoltage Monitoring (UNDER and UNDER + SEQ)

If the measured voltage (average value of the linked voltages) falls below the value set at the "MIN" controller, the set response delay ($D = \text{DELAY}$) starts (red "MIN" LED flashes). After the delay time has elapsed (red "MIN" LED is ON), the output relays drop out (yellow "REL" LED is OFF). If the measured voltage exceeds the value set at the "MIN" controller, the output relays pick up again (yellow "REL" LED is ON). The adjustable overvoltage threshold or the permanently set asymmetry also make it possible to detect the phase failure despite reverse voltages.



Phase Sequence Monitoring (SEQ)

If the phase direction changes (red "SEQ" LED is ON), the output relays drop out without delay (yellow "R" LED is OFF).

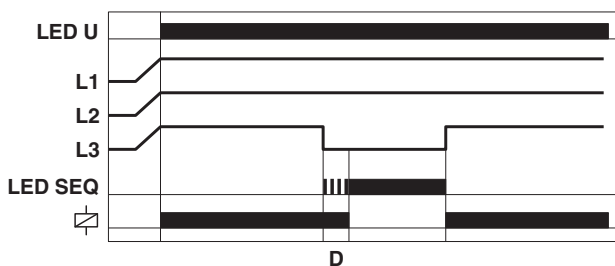

Phase failure monitoring

In the event that one of the phase voltages fails, the set response delay ($D = \text{DELAY}$) starts (red "SEQ" LED flashes). After the time delay has elapsed (red "SEQ" LED is ON), the output relays drops out (yellow "REL" LED is OFF). Reverse voltages (e.g. motors continuing to run on 2 phases) are not detected by this function but by monitoring the asymmetry with an appropriate selection of switching threshold.



SCATTERGOOD & JOHNSON LTD

ELECTRICAL ENGINEERING & FLUID CONTROL DISTRIBUTORS

Est.1899

At Scattergood & Johnson Ltd, we pride ourselves on being a technical distributor to specialist industries.

Working with a range of quality product suppliers across a number of specialist markets, we are not your average 'box shifter' - we are your technical and supply chain partner.

We fully support every product we sell - for free! Our internal team and external sales engineers can answer any product or application question, no matter the complexity.

Backing up this technical ability is a range of 50,000+ products available from stock for nationwide next day delivery (same day if required!), or you can collect what you need from any of our trade counters around the UK.

Select your specialist interest below to learn more about how we can help.



Online, In Branch and On the Road - Scattergood & Johnson Ltd, there when you need us.

www.scatts.co.uk