

PSR-...-24UC/ESAM4/8X1/1X2

PL
EN ISO 13849

SILCL
IEC 62061



Safety relay for emergency stop and safety door monitoring

Data sheet
100021_en_05

© PHOENIX CONTACT 2016-04-29

1 Description

Intended Use

The safety relay is used for the emergency stop and safety door monitoring.

The safety relay interrupts circuits in a safety-related way.

Possible signal generators

- Emergency stop button
- Door locking mechanisms

Contact type

- 8 undelayed enabling current paths
- 1 undelayed enabling current path

The enabling current paths and the signaling current path drop out without delay according to stop category 0 (EN 60204-1).

Control

- Single or two channel
- Automatic or manual, monitored start

Achievable safety integrity

- Suitable up to category 4, PL e (EN ISO 13849-1), SILCL 3 (EN 62061)

Additional features

- Cross circuiting detection
- Option of screw or spring-cage terminal blocks for plug-in
- 45 mm housing width

Approvals



WARNING: Risk of electric shock

Observe the safety regulations and installation notes in the corresponding section.



Make sure you always use the latest documentation.

It can be downloaded from the product at phoenixcontact.net/products.



This document is valid for the products listed in the "Ordering data".

This document meets the same requirements as the original operating instructions with respect to the contents.

2	Table of contents	
1	Description	1
2	Table of contents	2
3	Ordering data	3
4	Technical data	3
5	Safety regulations and installation notes.....	7
6	Function description	8
	6.1 Single-channel sensor circuit	8
	6.2 Two-channel sensor circuit	8
	6.3 Automatic start.....	8
	6.4 Manual, monitored start.....	8
	6.5 Safe shutdown	8
7	Function and time diagrams	8
	7.1 Time diagram for automatic start, two-channel control.....	8
	7.2 Time diagram for manual start, single-channel control.....	8
8	Basic circuit diagram	9
9	Derating.....	9
	9.1 Any mounting position.....	9
10	Load curve.....	9
	10.1 Ohmic load	9
11	Operating and indication elements	10
	11.1 Connection versions	10
	11.2 Connection assignment.....	10
12	Mounting and removing	11
13	Wiring	11
	13.1 Signal generator connection versions	11
	13.2 Start and feedback circuit connection variants	12
14	Startup.....	12
15	Calculating the power dissipation	12
16	Diagnostics.....	12
17	Application examples	13
	17.1 Single-channel emergency stop monitoring	13
	17.2 Two-channel emergency stop monitoring	14
	17.3 Single-channel safety door monitoring	15
	17.4 Two-channel safety door monitoring	16
18	Attachment	17
	18.1 Using PSR devices at altitudes greater than 2000 m above sea level	17
	18.2 Revision history.....	18

3 Ordering data

Description	Type	Order No.	Pcs./Pkt.
Safety relay for emergency stop and safety door monitoring up to SIL 3 or Cat. 4, PL e according to EN ISO 13849, single- or two-channel operation, 8 enabling current paths, $U_S = 24$ V AC/DC, plug-in screw terminal block	PSR-SCP- 24UC/ESAM4/8X1/1X2	2963912	1
Safety relay for emergency stop and safety door monitoring up to SIL 3 or Cat. 4, PL e according to EN ISO 13849, single- or two-channel operation, 8 enabling current paths, $U_S = 24$ V AC/DC, plug-in spring-cage terminal block	PSR-SPP- 24UC/ESAM4/8X1/1X2	2963996	1
Documentation	Type	Order No.	Pcs./Pkt.
User manual, English, for applications for PSR safety relay	UM EN SAFETY RELAY APPLICATION	2888712	1

4 Technical data

Hardware/firmware version	
HW/FW	≥ 10/-- (2963912) ≥ 08/-- (2963996)
The technical data and safety characteristics are valid as of the specified HW/FW version.	
Input data	
Rated control circuit supply voltage U_S	24 V AC/DC -15 % / +10 %
Rated control supply current I_S	typ. 177 mA AC typ. 93 mA DC
Typical inrush current	2 A ($\Delta t = 10$ ms at U_S) < 60 mA (with U_S/I_x to S10) < 110 mA (with U_S/I_x to S12) > -110 mA (with U_S/I_x to S22) < 60 mA (with U_S/I_x to S34) < 60 mA (with U_S/I_x to S35)
Current consumption	< 50 mA (with U_S/I_x to S10) < 50 mA (with U_S/I_x to S12) > -50 mA (with U_S/I_x to S22) 0 mA (with U_S/I_x to S34) 0 mA (with U_S/I_x to S35)
Power consumption at U_S	typ. 4.25 W (AC) typ. 2.23 W (DC)
Voltage at input/start and feedback circuit	24 V DC -15 % / +10 %
Filter time	2 ms (at A1 in the event of voltage dips at U_S) max. 1.5 ms (at S10, S12; test pulse width) 7.5 ms (at S10, S12; test pulse rate) Test pulse rate = 5 x Test pulse width
Max. permissible overall conductor resistance (Input and reset circuit at U_S)	approx. 11 Ω (Input and start circuits at U_S)
Typical response time at U_S	< 380 ms (automatic start) < 60 ms (manual start)
Typical starting time with U_S	< 500 ms (when controlled via A1)
Typical release time with U_S	< 20 ms (when controlled via S11/S12 and S21/S22) < 50 ms (when controlled via A1)
Recovery time	< 1 s
Maximum switching frequency	0.5 Hz
Concurrence input 1/2	∞
Operating voltage display	1 x green LED
Status display	2 x green LEDs
Protective circuit	Surge protection Suppressor diode and varistors

Output data	
Contact type	8 enabling current paths 1 signaling current path
Contact material	AgSnO ₂
Minimum switching voltage	5 V AC/DC
Maximum switching voltage	250 V AC/DC (Observe the load curve)
Limiting continuous current	6 A (N/O contact, pay attention to the derating) 6 A (N/C contact)
Maximum inrush current	20 A ($\Delta t \leq 100$ ms)
Inrush current, minimum	10 mA
Sq. Total current $I_{TH}^2 = I_1^2 + I_2^2 + \dots + I_N^2$	50 A ² (observe derating)
Interrupting rating (ohmic load) max.	144 W (24 V DC, $\tau = 0$ ms) 288 W (48 V DC, $\tau = 0$ ms) 110 W (110 V DC, $\tau = 0$ ms) 88 W (220 V DC, $\tau = 0$ ms) 1500 VA (250 V AC, $\tau = 0$ ms)
Maximum interrupting rating (inductive load)	42 W (24 V DC, $\tau = 40$ ms) 42 W (48 V DC, $\tau = 40$ ms) 42 W (110 V DC, $\tau = 40$ ms) 42 W (220 V DC, $\tau = 40$ ms)
Switching capacity min.	50 mW
Mechanical service life	10 x 10 ⁶ cycles
Switching capacity (360/h cycles)	4 A (24 V DC) 4 A (230 V AC)
Switching capacity (3600/h cycles)	2.5 A (24 V (DC13)) 3 A (230 V (AC15))
Output fuse	10 A gL/gG (N/O contact) 6 A gL/gG (N/C contact)
General data	
Relay type	Electromechanical relay with forcibly guided contacts in accordance with EN 50205
Nominal operating mode	100% operating factor
Degree of protection	IP20
Min. degree of protection of inst. location	IP54
Mounting type	DIN rail mounting
Mounting position	any
Type of housing	PBT yellow
Air clearances and creepage distances between the power circuits	according to DIN EN 50178/VDE 0160
Rated insulation voltage	250 V AC
Rated surge voltage/insulation	Basic insulation 4 kV: between all current paths and housing Safe isolation, reinforced insulation 6 kV: between A1/A2 and 63/64, 73/74, 83/84 between S10/S11/S12/S33/S34/S35 and 63/64, 73/74, 83/84 between 63/64, 73/74, 83/84 among one another
Degree of pollution	2
Overvoltage category	III

Dimensions	Screw connection	Spring-cage connection
W x H x D	45 x 99 x 114.5 mm	45 x 112 x 114.5 mm

Connection data	Screw connection	Spring-cage connection
Conductor cross section, solid	0.2 mm ² ... 2.5 mm ²	0.2 mm ² ... 1.5 mm ²
Conductor cross section, flexible	0.2 mm ² ... 2.5 mm ²	0.2 mm ² ... 1.5 mm ²
Conductor cross section AWG/kcmil	24 ... 12	24 ... 16
Stripping length	7 mm	8 mm
Screw thread	M3	

Ambient conditions	
Ambient temperature (operation)	-20 °C ... 55 °C (observe derating)
Ambient temperature (storage/transport)	-40 °C ... 70 °C
Max. permissible relative humidity (operation)	75 % (on average, 85% infrequently, non-condensing)
Max. permissible humidity (storage/transport)	75 % (on average, 85% infrequently, non-condensing)
Maximum altitude	≤ 2000 m (Above sea level)
Information on operating height	See the "Using PSR devices at altitudes greater than 2000 m above sea level" section
Shock	15g
Vibration (operation)	10 Hz ... 150 Hz, 2g

Conformance / approvals	
Conformance	CE-compliant
The full EC Declaration of Conformity can be downloaded for the product at phoenixcontact.net/products .	
Approvals	

Safety data	
Stop category according to IEC 60204	0

Safety parameters for IEC 61508 - High demand	
SIL	3
PFH _D	5.06 x 10 ⁻¹⁰
Demand rate	< 12 Months
Proof test interval	240 Months
Duration of use	240 Months
The specifications apply assuming the following calculation basis	
B _{10D}	230000 (At 3 A AC15)
d _{op}	365.25 Days
h _{op}	24 h
t _{Cycle}	3600 s

Safety parameters for IEC 61508 - Low demand	
SIL	3
PFD _{avg}	1.48 x 10 ⁻⁴
Proof test interval	77 Months
Duration of use	240 Months

Safety characteristic data according to EN ISO 13849

Category	4
Performance level	e
Duration of use	240 Months
For applications in PL e, the required demand rate for the safety function is once per month.	
Calculation basis	
B _{10D}	230000 (At 3 A AC15)
d _{op}	365.25 Days
t _{op}	24 h
t _{Cycle}	3600 s

Safety parameters for EN 62061

SILCL	3
-------	---

5 Safety regulations and installation notes



WARNING: Death, serious personal injury or damage to equipment

Depending on the application, incorrect handling of the device may pose serious risks for the user or cause damage to equipment.

- Observe all the safety notes and warning instructions provided in this chapter and elsewhere in this document.

General

- Observe the safety regulations of electrical engineering and industrial safety and liability associations.

Disregarding these safety regulations may result in death, serious personal injury or damage to equipment.

- Only use power supply units with safe isolation and SELV/PELV according to EN 50178/VDE 0160.

Startup, mounting, and modifications

Startup, mounting, modifications, and upgrades may only be carried out by an electrically skilled person.

- Before working on the device, disconnect the power.
- Carry out wiring according to the application. Refer to the “Application examples” section for this.

Reliable operation is only ensured if the device is installed in housing protected from dust and humidity.

- Install the device in housing protected from dust and humidity (min. IP54).

In operation

During operation, parts of electrical switching devices carry hazardous voltages.

- Protective covers must not be removed when operating electrical switching devices.

For emergency stop applications, automatic startup of the machine can pose serious risks for the user.

- The machine must be prevented from restarting automatically by a higher-level controller.

With the manual, monitored reset device, a machine start may not be triggered in accordance with EN ISO 13849-1.

Inductive loads can lead to welded relay contacts.

- Connect a suitable and effective protective circuit to inductive loads.
- Implement the protective circuit parallel to the load and not parallel to the switch contact.

Noise emission may occur when operating relay modules. Wireless reception may be disrupted in residential areas.

The device is a Class A product.

- Observe the requirements for noise emission for electrical and electronic equipment (EN 61000-6-4).
- Implement appropriate precautions against noise emission.

Surge voltages can destroy the device.

- Make sure that the output voltage of the voltage supply does not exceed 37 V even in the event of error.

Faulty devices

The devices may be damaged following an error. Correct operation can no longer be ensured.

- In the event of an error, replace the device.

Only the manufacturer or their authorized representative may perform the following activities. Otherwise the warranty is invalidated.

- Repairs to the device
- Opening the housing

Taking out of service and disposal

- Dispose of the device in accordance with environmental regulations.
- Make sure that the device can never be reused.

6 Function description

6.1 Single-channel sensor circuit

The sensor circuit is not designed with redundancy.

The safety relay does not detect short and cross-circuits in the sensor circuit.

6.2 Two-channel sensor circuit

The sensor circuit is designed with redundancy.

Depending on the wiring, the safety relay has cross-circuit detection.

With the corresponding wiring, the safety relay detects short and cross-circuits in the sensor circuit.

6.3 Automatic start

The device starts automatically after the sensor circuit has been closed.

6.4 Manual, monitored start

The device starts with closed sensor circuit once the start circuit has been closed by pressing the reset button.

A connected reset button (connected to S33/S34) is monitored.

6.5 Safe shutdown

When the sensor circuit is opened, the enabling current paths 13/14 ... 83/84 open without delay.

When the enabling current paths are open, the device is in the safe state.

The signaling current path closes.

7 Function and time diagrams

7.1 Time diagram for automatic start, two-channel control

- Cross-circuit detection activated

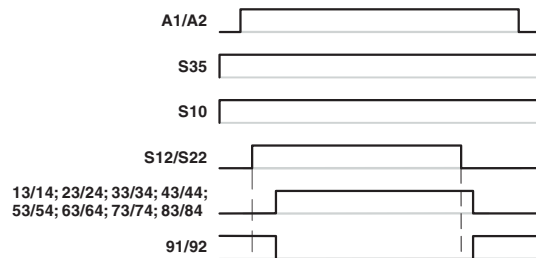

Figure 1 Time diagram for automatic start, two-channel control

7.2 Time diagram for manual start, single-channel control

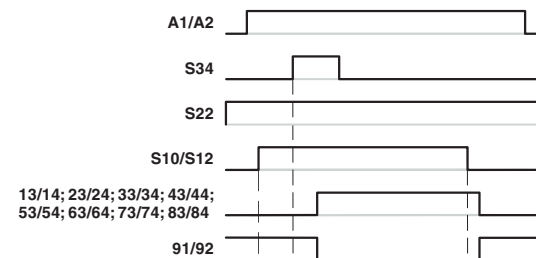

Figure 2 Time diagram for manual start, single-channel control

Key:

A1/A2	Power supply
S34	Start circuit
S35	Start circuit
S10 / S12 / S22	Input sensor circuit
13/14 ... 83/84	Undelayed enabling current paths
91/92	Signaling current path, undelayed

8 Basic circuit diagram

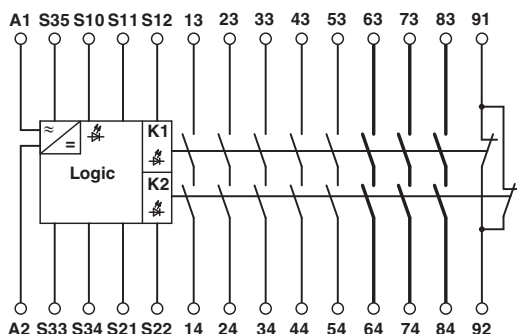

Figure 3 Block diagram

Key:

A1	24 V AC/DC power supply
A2	0 V power supply
S33, S34, S35	Start and feedback circuit
S10, S11, S12	Input sensor circuit (channel 1)
S11	Output 24 V
S21	Output 0 V
S22	Input sensor circuit (channel 2)
13/14 ... 83/84	Undelayed enabling current paths
91/92	Signaling current path, undelayed

9 Derating

9.1 Any mounting position

The derating curve applies for the following conditions:

- Mounting on a DIN rail in any mounting position
- Devices mounted next to each other without spacing

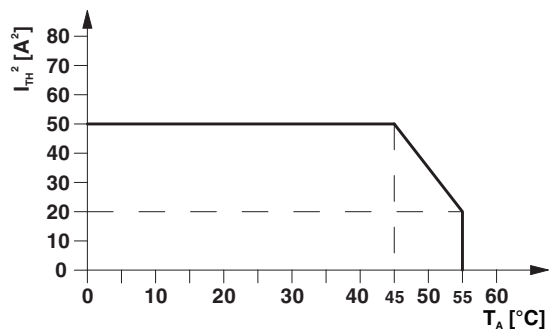

Figure 4 Derating curve - any mounting position, without spacing

10 Load curve

10.1 Ohmic load

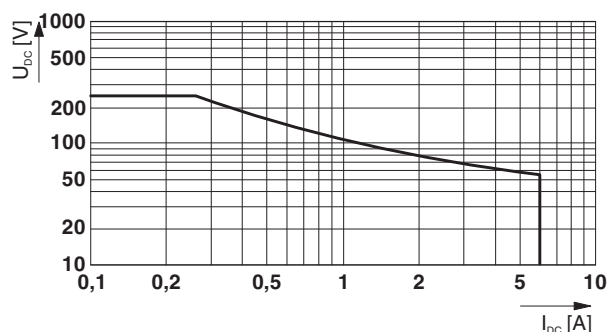

Figure 5 Relay load curve - ohmic load

11 Operating and indication elements

11.1 Connection versions

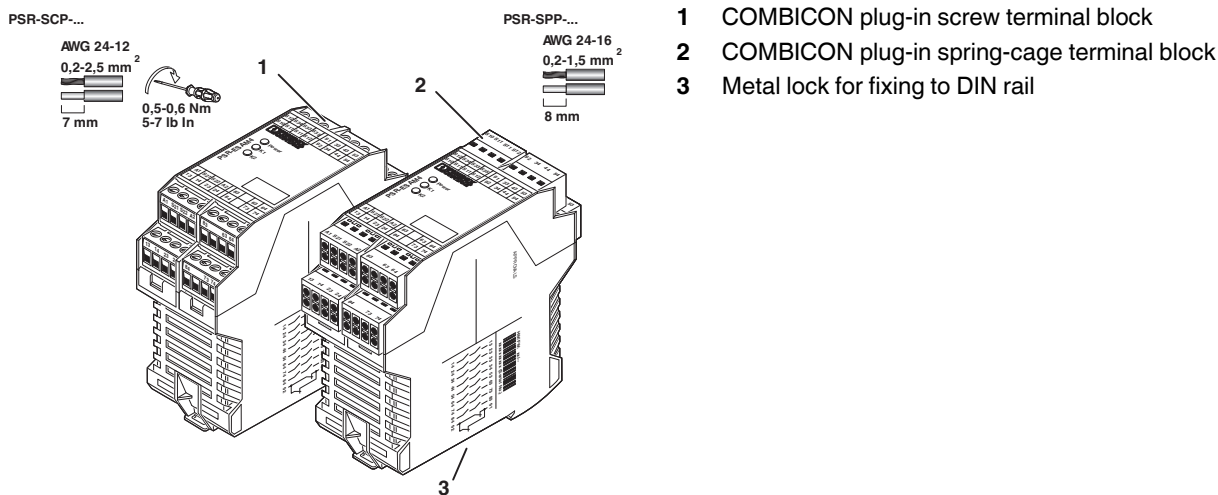
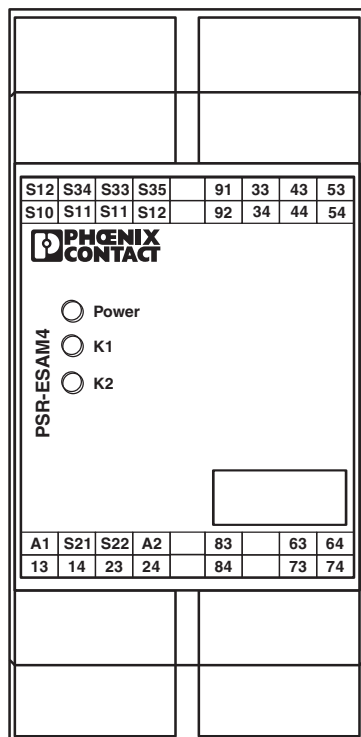

Figure 6 Connection versions

11.2 Connection assignment



- S10, S12** Input sensor circuit (channel 1)
- S33, S34, S35** Start and feedback circuit
- S11** Output 24 V
- 91/92** Signaling current path, undelayed
- 33/34**
- 43/44** Undelayed enabling current paths
- 53/54**
- Power** Power LED (green)
- K1** Status indicator safety circuit; LED (green)
- K2** Status indicator safety circuit; LED (green)
- A1** 24 V AC/DC power supply
- S21** Output 0 V
- S22** Input sensor circuit (channel 2)
- A2** 0 V power supply
- 13/14**
- 23/24**
- 83/84** Undelayed enabling current paths
- 63/64**
- 73/74**

12 Mounting and removing

- Mount the device on a 35 mm DIN rail according to EN 60715.
- To remove the device, use a screwdriver to release the snap-on foot.

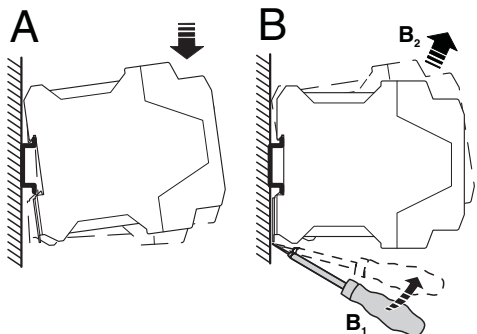

Figure 7 Mounting and removing

13 Wiring

- Connect the cables to the connection terminal blocks using a screwdriver.

PSR-SCP-...

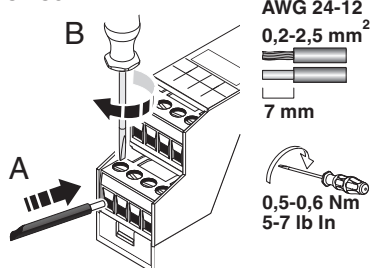

Figure 8 Connecting the cables for PSR-SCP-... (Screw terminal block)

PSR-SPP-...

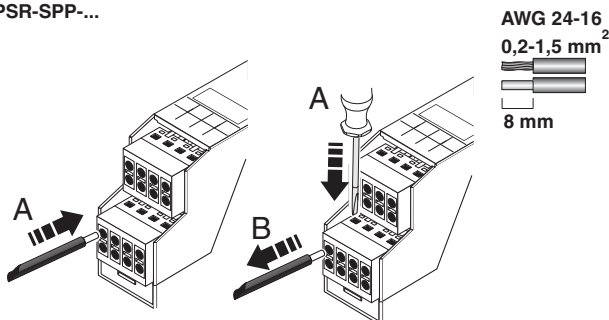

Figure 9 Connecting the cables for PSR-SPP-... (Spring-cage terminal block)



It is recommended that ferrules are used to connect stranded cables.



For compliance with UL approval, use copper wire that is approved up to 60°C/75°C.

13.1 Signal generator connection versions

- Connect suitable signal generators to S10/S11/S12 and S21/S22.

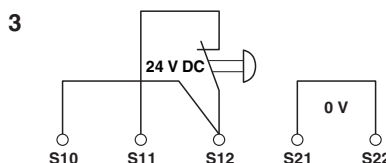
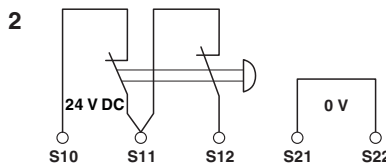
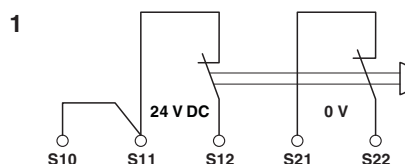

Figure 10 Signal generator connection versions

- 1 Two-channel connection with cross-circuit monitoring
- 2 Two-channel connection without cross-circuit monitoring
- 3 Single-channel connection

13.2 Start and feedback circuit connection variants

Automatic start

- Bridge the contacts S33/S35.

Manual, monitored start

- Connect a reset button to contacts S33/S34.

A connected reset button is monitored.

Start and feedback circuit

- Place the relevant N/C contact in path S33/S34 or S33/S35 to monitor external contactors or extension devices with force-guided contacts.

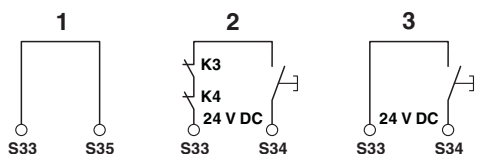

Figure 11 Start and feedback circuit connection variants

- 1 Automatic start
- 2 Manual, monitored start with monitored contact extension
- 3 Manual, monitored start

14 Startup

- Apply the rated control circuit supply voltage (24 V AC/DC) at terminal blocks A1/A2.

The Power LED lights up.

- Close contacts S10/S11/S12 and S21/S22

Automatic start

The enabling current paths 13/14 ... 83/84 close.

Signaling current path 91/92 opens.

The K1 and K2 LEDs light up.

Manual, monitored start

- Press the reset button.

The enabling current paths 13/14 ... 83/84 close.

Signaling current path 91/92 opens.

The K1 and K2 LEDs light up.

15 Calculating the power dissipation



The total power dissipation of the safety relay is based on the input power dissipation and the contact power dissipation for the same and for different load currents.

Input power dissipation

$$P_{\text{Input}} = U_B^2 / (U_S / I_S)$$

Contact power dissipation

With the same load currents:

$$P_{\text{Contact}} = n \cdot I_L^2 \cdot 200 \text{ m}\Omega$$

With different load currents:

$$P_{\text{Contact}} = (I_{L1}^2 + I_{L2}^2 + \dots + I_{Ln}^2) \cdot 200 \text{ m}\Omega$$

Total power dissipation

$$P_{\text{Total}} = P_{\text{Input}} + P_{\text{Contact}}$$

therefore

$$P_{\text{Total}} = U_B^2 / (U_S / I_S) + n \cdot I_L^2 \cdot 200 \text{ m}\Omega$$

or

$$P_{\text{Total}} = U_B^2 / (U_S / I_S) + (I_{L1}^2 + I_{L2}^2 + \dots + I_{Ln}^2) \cdot 200 \text{ m}\Omega$$

Key:

P	Power dissipation in mW
U_B	Applied operating voltage
U_S	Rated control circuit supply voltage
I_S	Rated control supply current
n	Number of enabling current paths used
I_L	Contact load current

16 Diagnostics

For the diagnostic description, please refer to the application manual for PSR safety relays.

Function test/proof test



Use the function test to test the safety function. To do this, request the safety function once by pressing the emergency stop button, for example. Check whether the safety function is executed correctly by then switching the device on again via the sensor circuits.

17 Application examples

17.1 Single-channel emergency stop monitoring

- Manual, monitored start
- Monitoring of external contactors
- Suitable up to category 1, PL c (EN ISO 13849-1), SIL 1 (EN 62061)

i For an automatic start, bridge contacts S33 and S35.

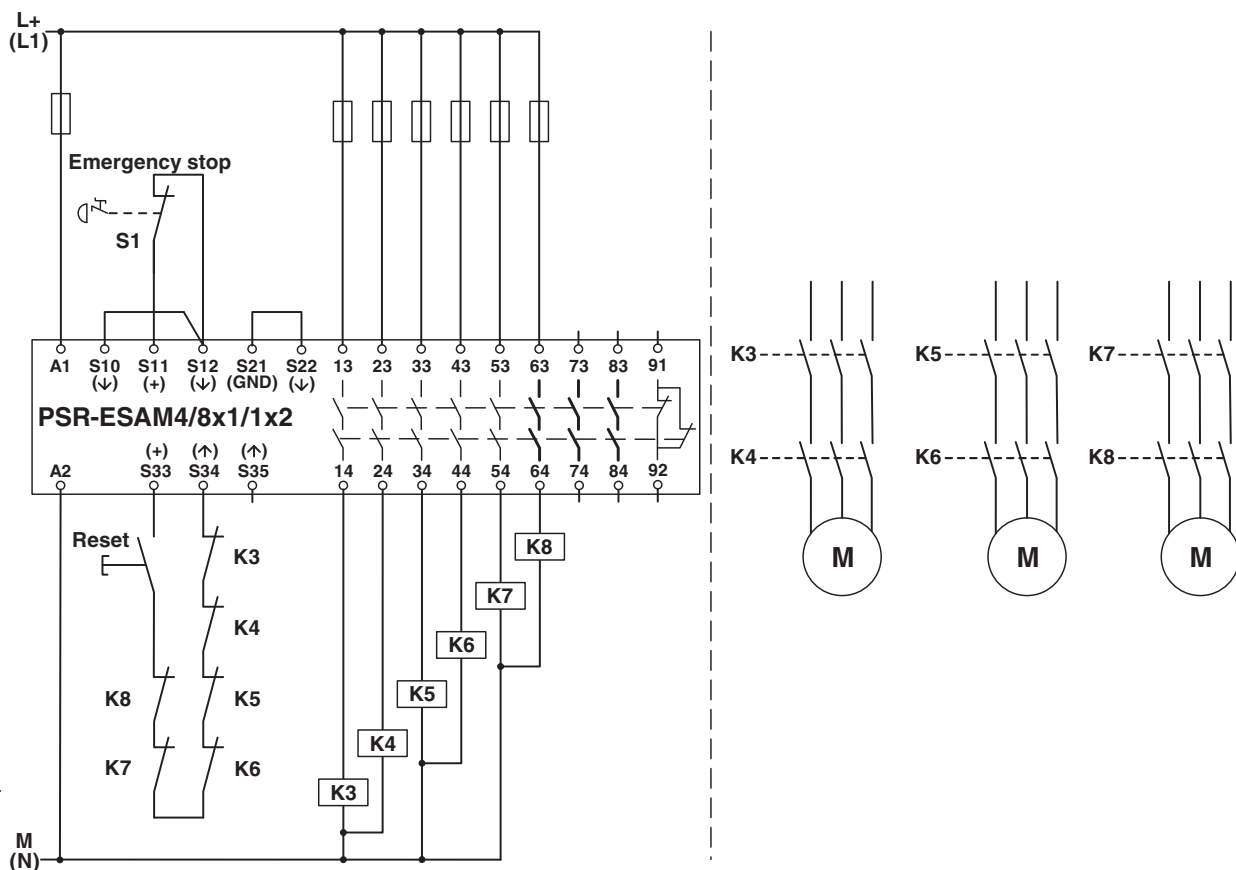

Figure 12 Single-channel emergency stop monitoring

Key:

- S1** Emergency stop button
- K3 ... K8** Contactors

17.2 Two-channel emergency stop monitoring

- Manual, monitored start
- Monitoring of external contactors
- Cross circuiting detection
- Suitable up to category 4, PL e (EN ISO 13849-1),
- SIL 3 (EN 62061)

i For an automatic start, bridge contacts S33 and S35.

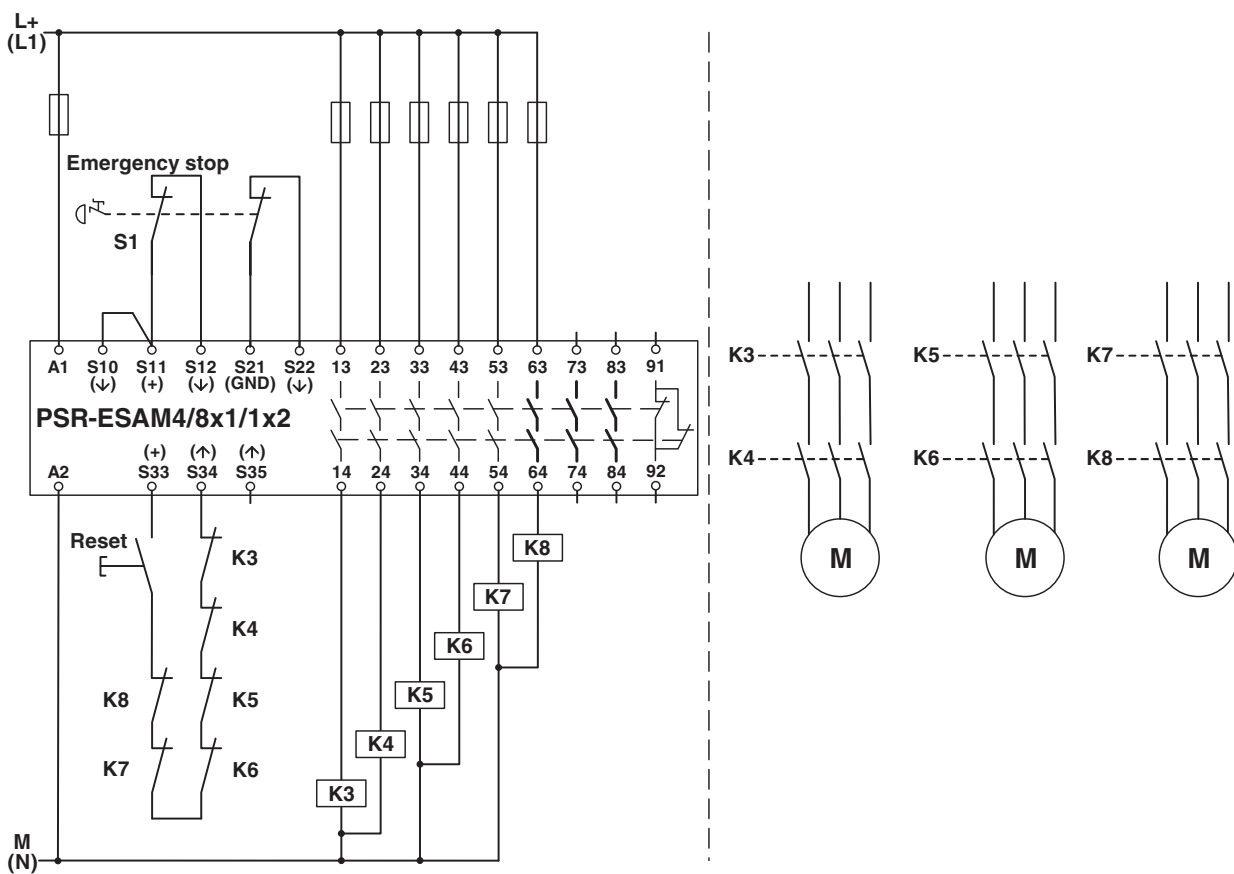

Figure 13 Two-channel emergency stop monitoring

Key:

- S1** Emergency stop button
- K3 ... K8** Contactors

17.3 Single-channel safety door monitoring

- Manual, monitored start
- Monitoring of external contactors
- Suitable up to category 1, PL c (EN ISO 13849-1), SIL 1 (EN 62061)

i For an automatic start, bridge contacts S33 and S35.

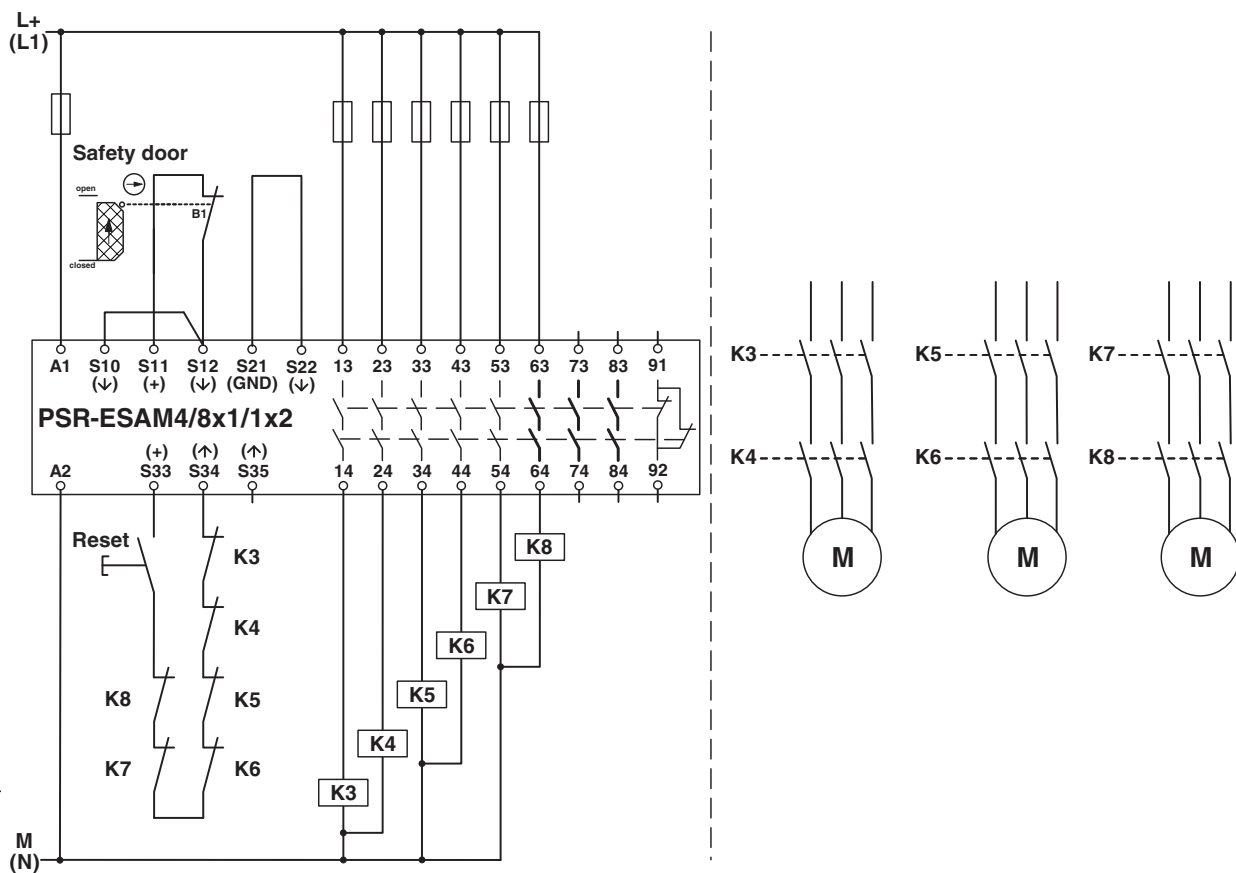

Figure 14 Single-channel safety door monitoring

Key:

- B1** Mechanical safety door switch
- K3 ... K8** Contactors

17.4 Two-channel safety door monitoring

- Manual, monitored start
- Monitoring of external contactors
- Cross circuiting detection
- Suitable up to category 4, PL e (EN ISO 13849-1), SIL 3 (EN 62061)



For an automatic start, bridge contacts S33 and S35.

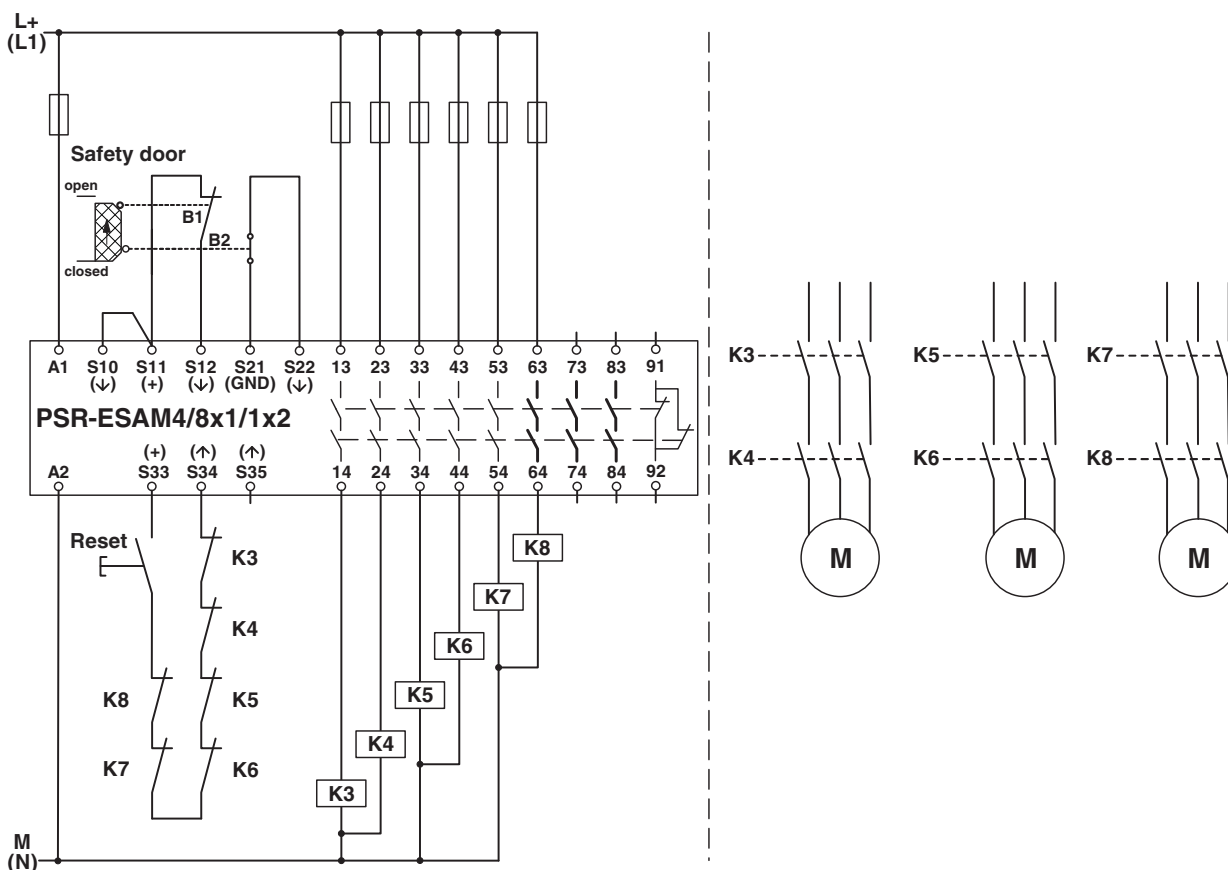

Figure 15 Two-channel safety door monitoring

Key:

- B1/B2** Mechanical safety door switches
- K3 ... K8** Contactors

18 Attachment

18.1 Using PSR devices at altitudes greater than 2000 m above sea level



The following section describes the special conditions for using PSR devices at altitudes greater than 2000 m above sea level. Observe the relevant device-specific data (technical data, derating, etc.) according to the product documentation for the individual device.

Using the device at altitudes **greater than 2000 m above sea level up to max. 4500 m above sea level** is possible under the following conditions:

1. Limit the rated control circuit supply voltage (U_S) in accordance with the table below. Observe the technical data for the device.

U_S according to the technical data for the device	U_S when used at altitudes greater than 2000 m above sea level
< 150 V AC/DC	U_S according to the technical data for the device still valid
> 150 V AC/DC	Limited to max. 150 V AC/DC

2. Limit the maximum switching voltage in accordance with the table below. Observe the technical data for the device.

Max. switching voltage according to the technical data for the device	Max. switching voltage when used at altitudes greater than 2000 m above sea level
< 150 V AC/DC	Max. switching voltage according to the technical data for the device still valid
> 150 V AC/DC	Limited to max. 150 V AC/DC

3. Reduce the maximum ambient temperature for operation by the corresponding factor in accordance with the table below.
4. If derating is specified, offset all the points of the derating curve by the corresponding factor in accordance with the table below.

Altitude above sea level	Temperature derating factor
2000 m	1
2500 m	0.953
3000 m	0.906
3500 m	0.859
4000 m	0.813
4500 m	0.766

Example calculation for 3000 m



The following calculation and the illustrated derating curve are provided as examples. Perform the actual calculation and offset the derating curve for the device used according to the technical data and the "Derating" section.

$$27\text{ °C} \cdot 0.906 \approx 24\text{ °C}$$

$$55\text{ °C} \cdot 0.906 \approx 49\text{ °C}$$

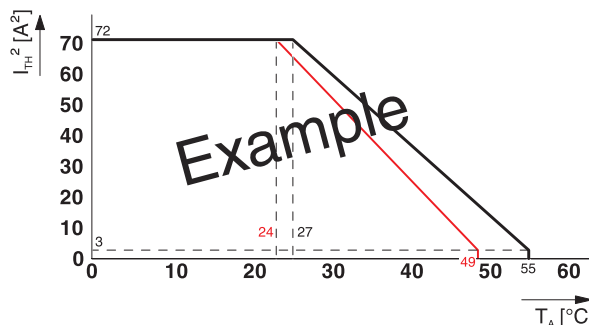

Figure 16 Example of a suspended derating curve (red)

18.2 Revision history

Version	Date	Contents
05	2016-02-03	New edition of the data sheet



SCATTERGOOD & JOHNSON LTD

ELECTRICAL ENGINEERING & FLUID CONTROL DISTRIBUTORS

Est.1899

At Scattergood & Johnson Ltd, we pride ourselves on being a technical distributor to specialist industries.

Working with a range of quality product suppliers across a number of specialist markets, we are not your average 'box shifter' - we are your technical and supply chain partner.

We fully support every product we sell - for free! Our internal team and external sales engineers can answer any product or application question, no matter the complexity.

Backing up this technical ability is a range of 50,000+ products available from stock for nationwide next day delivery (same day if required!), or you can collect what you need from any of our trade counters around the UK.

Select your specialist interest below to learn more about how we can help.



Online, In Branch and On the Road - Scattergood & Johnson Ltd, there when you need us.

www.scatts.co.uk