

# PSR-...-24-230UC/ESAM4/3X1/1X2

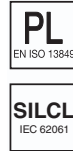

## Safety relay for emergency stop and safety door monitoring

Data sheet  
102404\_en\_04

© PHOENIX CONTACT 2015-04-08

### 1 Description

The safety relay can be used in safety circuits according to EN 60240-1 and IEC 61508.

With this switching device, circuits are interrupted in a safety-oriented manner.

Control is via a single channel or two channels, either with automatic or manual start circuit.

A connected reset button (connected to S33/S34) is monitored.

Depending on the external wiring, up to category 4, PL e according to EN ISO 13849-1 or SILCL 3 according to EN 62061 can be achieved.

The safety relay is equipped with three enabling current paths that drop out without delay corresponding to stop category 0 according to EN 60204-1.

The current paths are equipped with safe isolation.

A supply voltage in the range of 24 V ... 230 V AC or DC is possible for the safety relay.

### Features

- Emergency stop and safety door monitoring
- Suitable up to category 4, PL e (EN ISO 13849-1), SILCL 3 (EN 62061)
- Option of screw or spring-cage terminal blocks for plug-in
- Single-channel or two-channel wiring with cross-circuit detection
- Safe isolation
- 3 enable current paths
- 1 signaling current path
- Housing width of 45 mm
- Supply voltage range of 24 V ... 30 V AC/DC



#### **WARNING: Risk of electric shock**

Observe the safety instructions in the corresponding section!



Make sure you always use the latest documentation.  
It can be downloaded from the product at [phoenixcontact.net/products](http://phoenixcontact.net/products).



This data sheet is valid for all products listed on the following pages.

---

<b>2</b>	<b>Table of contents</b>	
1	Description .....	1
2	Table of contents .....	2
3	Ordering data .....	3
4	Technical data .....	3
5	Basic circuit diagram .....	6
6	Derating .....	6
7	Safety notes .....	7
8	Operating and indication elements .....	8
9	Diagnostics .....	8
10	Application examples .....	9
10.1	Single-channel safety door monitoring .....	9
10.2	Single-channel emergency stop monitoring .....	9
10.3	Two-channel safety door monitoring .....	9
10.4	Two-channel emergency stop monitoring .....	9

### 3 Ordering data

Description	Type	Order No.	Pcs. / Pkt.
Safety relay for emergency stop and safety door monitoring up to SIL 3 or Cat. 4, PL e according to EN ISO 13849, single or two-channel operation, 3 enabling current paths, nominal input voltage of 24 ... 230 V AC/DC, plug-in screw terminal blocks	PSR-SCP-24-230UC/ESAM4/3X1/1X2	2981114	1
Safety relay for emergency stop and safety door monitoring up to SIL 3 or Cat. 4, PL e according to EN ISO 13849, single or two-channel operation, 3 enabling current paths, nominal input voltage of 24 ... 230 V AC/DC, plug-in spring-cage terminal block	PSR-SPP-24-230UC/ESAM4/3X1/1X2	2981127	1
Documentation	Type	Order No.	Pcs. / Pkt.
User manual, English, for applications for PSR safety relay	UM EN SAFETY RELAY APPLICATION	2888712	1

### 4 Technical data

Hardware/firmware version	
HW/FW	≥ 08/-- (The technical data and safety characteristics are valid as of the specified HW/FW version.)
Input data	
Input voltage range	24 V AC/DC ... 230 V AC/DC
Input voltage range (factor)	0.85 ... 1.1
Typical input current	120 mA (at 24 V DC) 20 mA (for 120 V AC) 10 mA (for 230 V AC)
Voltage at input/start and feedback circuit	approx. 24 V DC
Max. permissible overall conductor resistance (Input and reset circuit at $U_N$ )	11 $\Omega$
Typical response time	50 ms (manual start) 60 ms (automatic start)
Typical pick-up time	500 ms (when controlled via A1)
Typical release time	20 ms (when controlled via S11/S12 and S21/S22) 50 ms (at 24 V DC) 110 ms (for 120 V AC) 280 ms (for 230 V AC)
Recovery time	1 s
Maximum switching frequency	0.5 Hz
Operating voltage display	1 x green LED
Status display	2 x green LEDs
Protective circuit	Surge protection Suppressor diode and varistors
Output data	
Contact type	3 enabling current paths 1 signaling current path
Contact material	AgSnO <sub>2</sub> , + 0.2 $\mu$ m Au
Minimum switching voltage	10 V AC/DC
Maximum switching voltage	250 V AC/DC
Limiting continuous current	6 A (N/O contact / N/C contact)
Maximum inrush current	6 A
Inrush current, minimum	10 mA
Sq. Total current	50 A <sup>2</sup> ( $I_{TH}^2 = I_1^2 + I_2^2 + \dots + I_N^2$ ) (see derating curve)

**Output data**

Interrupting rating (ohmic load) max.	192 W (24 V DC, $\tau = 0$ ms) 384 W (48 V DC, $\tau = 0$ ms) 80 W (110 V DC, $\tau = 0$ ms) 66 W (220 V DC, $\tau = 0$ ms) 2000 VA (250 V AC, $\tau = 0$ ms)
Maximum interrupting rating (inductive load)	48 W (24 V DC, $\tau = 40$ ms) 48 W (48 V DC, $\tau = 40$ ms) 48 W (110 V DC, $\tau = 40$ ms) 48 W (220 V DC, $\tau = 40$ ms)
Switching capacity min.	360 mW
Mechanical service life	Approx. $10^7$ cycles
Switching capacity (360/h cycles)	4 A (24 V (DC13)) 4 A (230 V (AC15))
Switching capacity (3600/h cycles)	2.5 A (24 V (DC13)) 3 A (230 V (AC15))
Output fuse	6 A gG NEOZED B6/C4A gL/gG automatic device

**General data**

Relay type	Electromechanically forcibly guided, dust-proof relay.
Nominal operating mode	100% operating factor
Degree of protection	IP20
Min. degree of protection of inst. location	IP54
Mounting position	any
Mounting type	DIN rail mounting
Clearances and creepage distances between the power circuits	DIN EN 50178/VDE 0160
Rated insulation voltage	250 V AC
Rated surge voltage/insulation	6 kV/safe isolation, reinforced insulation and 6 kV between input circuits and output contact current paths (13/14, 23/24, 33/34), as well as between output contact current paths (13/14, 23/24, 33/34).
Pollution degree	2
Surge voltage category	III

**Dimensions**

	<b>Screw connection</b>	<b>Spring-cage connection</b>
W x H x D	45 x 99 x 114.5 mm	45 x 112 x 114.5 mm

**Connection data**

	<b>Screw connection</b>	<b>Spring-cage connection</b>
Conductor cross section, solid	0.2 mm <sup>2</sup> ... 2.5 mm <sup>2</sup>	0.2 mm <sup>2</sup> ... 1.5 mm <sup>2</sup>
Conductor cross section, stranded	0.2 mm <sup>2</sup> ... 2.5 mm <sup>2</sup>	0.2 mm <sup>2</sup> ... 1.5 mm <sup>2</sup>
Conductor cross section AWG/kcmil	24 ... 12	24 ... 16
Stripping length	7 mm	8 mm

**Ambient conditions**

Ambient temperature (operation)	-20 °C ... 55 °C
Ambient temperature (storage/transport)	-25 °C ... 85 °C
Maximum altitude	≤ 2000 mm (Above sea level)

**Conformance / approvals**

Approvals	
-----------	---

**Safety data**

Stop category according to IEC 60204	0
--------------------------------------	---

**Safety parameters for IEC 61508 - High demand**

SIL	3
PFH <sub>d</sub>	$8.87 \times 10^{-10}$
Demand rate	< 12 Months
Proof test interval	240 Months
Duration of use	240 Months

Data only applies if the safety function is demanded at least once a year and the signal contact is read back.

The specifications apply assuming the following calculation basis

B <sub>10d</sub>	160000 (At 5 A DC 13)
d <sub>op</sub>	365.25 Days
h <sub>op</sub>	24 h
t <sub>Cycle</sub>	3600 s

**Safety parameters for IEC 61508 - Low demand**

SIL	3
MTTF <sub>d</sub>	18884 Years
PFD <sub>avg</sub>	$1.48 \times 10^{-4}$
Proof test interval	74 Months
Duration of use	240 Months

**Safety characteristic data according to EN ISO 13849**

Category	4
Performance level	e
CCF	Passed
Duration of use	240 Months

Data only applies if the safety function is demanded at least once a year and the signal contact is read back.

The specifications apply assuming the following calculation basis

B <sub>10d</sub>	160000 (At 5 A DC 13)
d <sub>op</sub>	365.25 Days
h <sub>op</sub>	24 h
t <sub>Cycle</sub>	3600 s

## 5 Basic circuit diagram

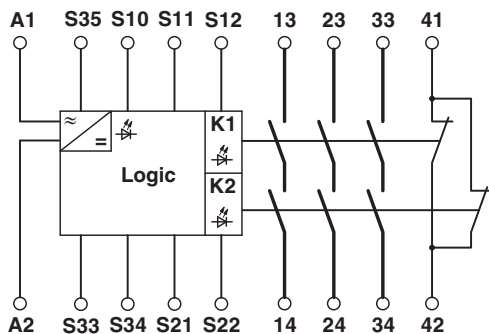

Figure 1 Block diagram

## 6 Derating

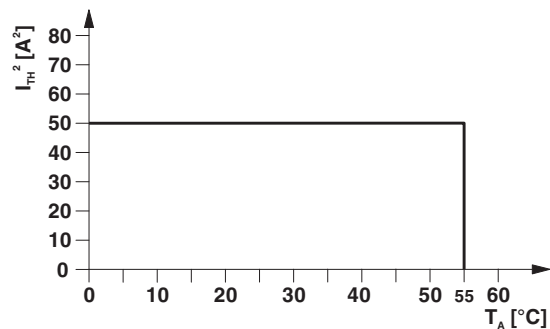

Figure 2 Derating curve

### Key:

Designation	Explanation
A1/A2	Safety relay input voltage
S10, S11, S12	Input circuits
S21/S22	Input circuit
S33, S34, S35	Start circuit
13/14	Undelayed enabling current paths
23/24	
33/34	
41/42	Signaling current path

## 7 Safety notes



### **WARNING: Risk of electric shock**

During operation, parts of electrical switching devices carry hazardous voltages.

Before working on the switching device, disconnect the power.

Please observe the safety regulations of electrical engineering and industrial safety and liability associations!

Disregarding these safety regulations may result in death, serious personal injury or damage to equipment.

Startup, mounting, modifications, and upgrades should only be carried out by a skilled electrical engineer!



### **WARNING: Risk of automatic machine restart!**

For emergency stop applications, the machine must be prevented from restarting automatically by a higher-level control system.

Protective covers must not be removed when operating electrical switching devices.



### **WARNING: Danger due to faulty devices!**

The devices may be damaged following an error and correct operation can no longer be ensured.

In the event of an error, replace the device immediately.

Repairs to the device, especially if the housing must be opened, may only be carried out by the manufacturer or authorized persons. Otherwise the warranty is invalidated.



### **NOTE: Risk of damage to equipment due to incorrect installation**

For reliable operation, the safety relay must be installed in housing protected from dust and humidity (IP54).

Carry out wiring according to the application. Refer to the "Application examples" section for this.



### **NOTE: Risk of damage to equipment due to noise emissions**

When operating relay modules the operator must meet the requirements for noise emission for electrical and electronic equipment (EN 61000-6-4) on the contact side and, if required, take appropriate measures.



Only use power supply units with safe isolation and SELV / PELV in accordance with EN 50178/VDE 0160 (SELV / PELV).

## 8 Operating and indication elements

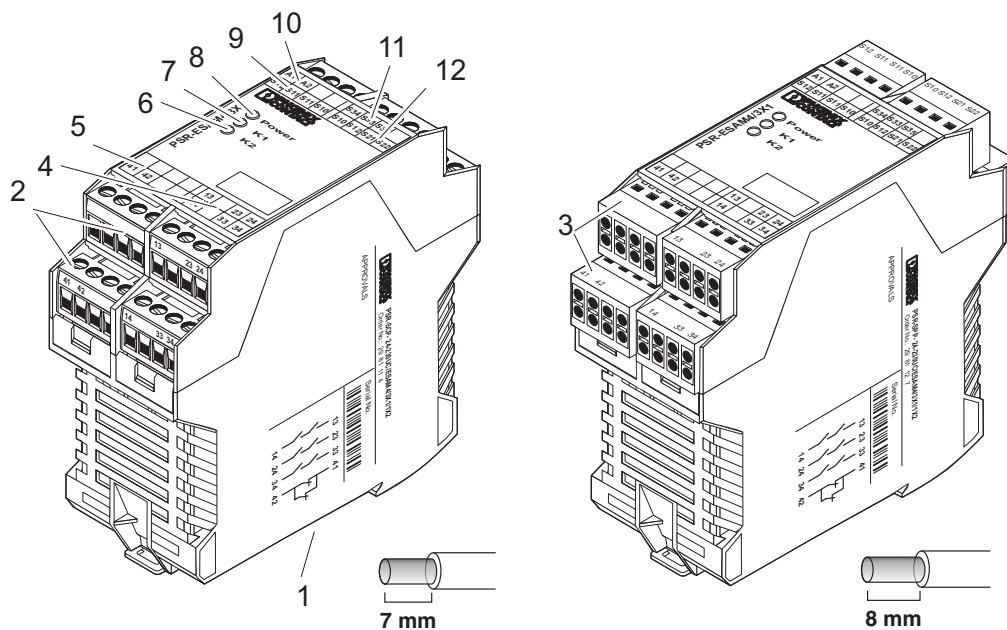

Figure 3 PSR-SCP-24-230UC/ESAM4/3X1/1X2 and PSR-SPP-24-230UC/ESAM4/3X1/1X2

### Key:

Designation	Explanation
1	Metal lock for mounting on the DIN rail
2	COMBICON plug-in screw terminal blocks
3	COMBICON plug-in spring-cage terminal blocks
4	13/14, 23/24, 33/34 - enabling current paths
5	41/42 signaling current path
6	LED status indicator, green - K2
7	LED status indicator, green - K1
8	LED status indicator, green - Power
9	S10, S11, S12 - input circuits
10	A1/A2 - supply voltage connection
11	S33, S34, S35 - start circuit (activating circuit)
12	S21/S22 - input circuit

## 9 Diagnostics

The diagnostic descriptions can be found in Section 7 of the application manual for PSR safety relays.

## 10 Application examples

### 10.1 Single-channel safety door monitoring

- Manual, monitored start
- Monitoring of external contactors
- Suitable up to category 1, PL c (EN ISO 13849-1), SILCL 1 (EN 62061)

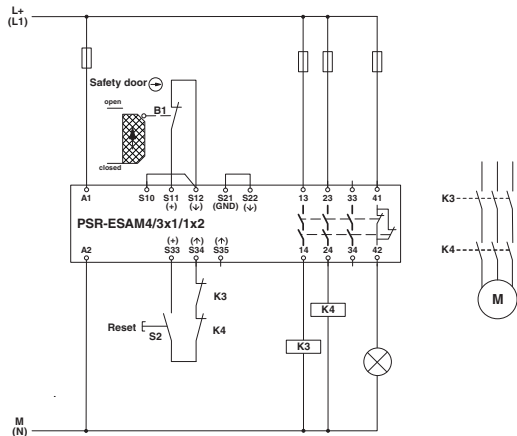

Figure 4 Single-channel safety door monitoring

### 10.2 Single-channel emergency stop monitoring

- Manual, monitored start
- Monitoring of external contactors
- Suitable up to category 1, PL c (EN ISO 13849-1), SILCL 1 (EN 62061)

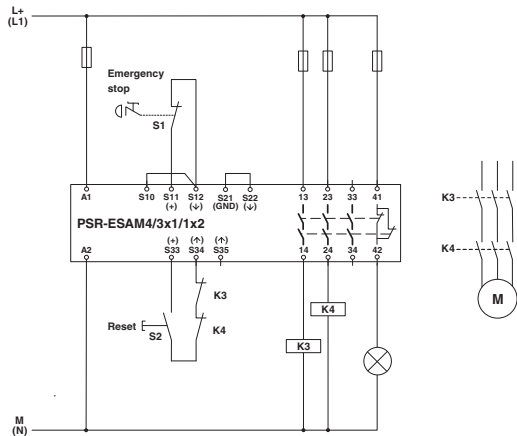

Figure 5 Single-channel emergency stop monitoring

### 10.3 Two-channel safety door monitoring

- Manual, monitored start
- Monitoring of external contactors
- Suitable up to category 4, PL e (EN ISO 13849-1), SILCL 3 (EN 62061)

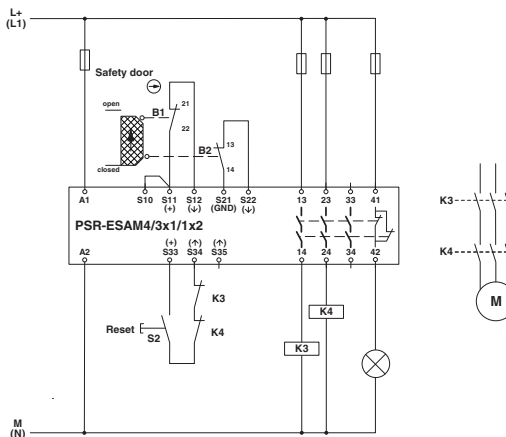

Figure 6 Two-channel safety door monitoring

### 10.4 Two-channel emergency stop monitoring

- Manual, monitored start
- Monitoring of external contactors
- Suitable up to category 4, PL e (EN ISO 13849-1), SILCL 3 (EN 62061)

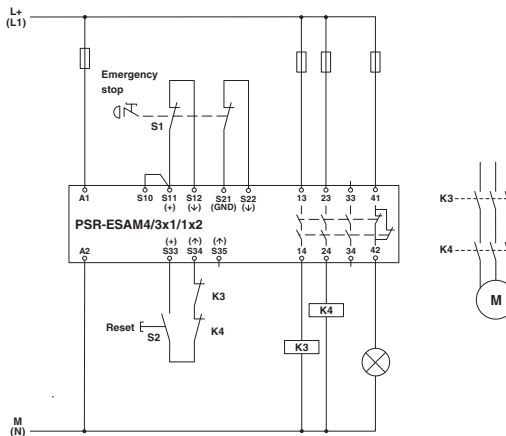

Figure 7 Two-channel emergency stop monitoring



# SCATTERGOOD & JOHNSON LTD

ELECTRICAL ENGINEERING & FLUID CONTROL DISTRIBUTORS

Est.1899

At Scattergood & Johnson Ltd, we pride ourselves on being a technical distributor to specialist industries.

Working with a range of quality product suppliers across a number of specialist markets, we are not your average 'box shifter' - we are your technical and supply chain partner.

We fully support every product we sell - for free! Our internal team and external sales engineers can answer any product or application question, no matter the complexity.

Backing up this technical ability is a range of 50,000+ products available from stock for nationwide next day delivery (same day if required!), or you can collect what you need from any of our trade counters around the UK.

Select your specialist interest below to learn more about how we can help.



Online, In Branch and On the Road - Scattergood & Johnson Ltd, there when you need us.

# [www.scatts.co.uk](http://www.scatts.co.uk)