



Parameterization and installation of the PSR-RSM4 safe speed monitor

User manual

UM EN PSR-CONF-WIN
Order No. 2888107

User manual

Parameterization and installation of the PSR-RSM4 safe speed monitor

2014-10-02

Designation: UM EN PSR-CONF-WIN

Revision: 03

Order No.: 2888107

This user manual is valid for:

| Designation | Revision | Order No. |
|-----------------------|----------|-----------|
| PSR-CONF-WIN1.0 | 1.0 | 2981554 |
| PSR-SCP-24DC/RSM4/4X1 | | 2981538 |
| PSR-SPP-24DC/RSM4/4X1 | | 2981541 |

Please observe the following notes

User group of this manual

The use of products described in this manual is oriented exclusively to:

- Qualified electricians or persons instructed by them, who are familiar with applicable standards and other regulations regarding electrical engineering and, in particular, the relevant safety concepts.
- Qualified application programmers and software engineers, who are familiar with the safety concepts of automation technology and applicable standards.

Explanation of symbols used and signal words



This is the safety alert symbol. It is used to alert you to potential personal injury hazards. Obey all safety measures that follow this symbol to avoid possible injury or death.

There are three different categories of personal injury that are indicated with a signal word.

DANGER This indicates a hazardous situation which, if not avoided, will result in death or serious injury.

WARNING This indicates a hazardous situation which, if not avoided, could result in death or serious injury.

CAUTION This indicates a hazardous situation which, if not avoided, could result in minor or moderate injury.



This symbol together with the signal word **NOTE** and the accompanying text alert the reader to a situation which may cause damage or malfunction to the device, hardware/software, or surrounding property.



This symbol and the accompanying text provide the reader with additional information or refer to detailed sources of information.

How to contact us

Internet

Up-to-date information on Phoenix Contact products and our Terms and Conditions can be found on the Internet at:

phoenixcontact.com

Make sure you always use the latest documentation.

It can be downloaded at:

phoenixcontact.net/products

Subsidiaries

If there are any problems that cannot be solved using the documentation, please contact your Phoenix Contact subsidiary.

Subsidiary contact information is available at phoenixcontact.com.

Published by

PHOENIX CONTACT GmbH & Co. KG
 Flachsmarktstraße 8
 32825 Blomberg
 GERMANY

Should you have any suggestions or recommendations for improvement of the contents and layout of our manuals, please send your comments to:

tecdoc@phoenixcontact.com

Please observe the following notes

General terms and conditions of use for technical documentation

Phoenix Contact reserves the right to alter, correct, and/or improve the technical documentation and the products described in the technical documentation at its own discretion and without giving prior notice, insofar as this is reasonable for the user. The same applies to any technical changes that serve the purpose of technical progress.

The receipt of technical documentation (in particular user documentation) does not constitute any further duty on the part of Phoenix Contact to furnish information on modifications to products and/or technical documentation. You are responsible to verify the suitability and intended use of the products in your specific application, in particular with regard to observing the applicable standards and regulations. All information made available in the technical data is supplied without any accompanying guarantee, whether expressly mentioned, implied or tacitly assumed.

In general, the provisions of the current standard Terms and Conditions of Phoenix Contact apply exclusively, in particular as concerns any warranty liability.

This manual, including all illustrations contained herein, is copyright protected. Any changes to the contents or the publication of extracts of this document is prohibited.

Phoenix Contact reserves the right to register its own intellectual property rights for the product identifications of Phoenix Contact products that are used here. Registration of such intellectual property rights by third parties is prohibited.

Other product identifications may be afforded legal protection, even where they may not be indicated as such.

Table of contents

| | | |
|---|--|----|
| 1 | For your safety | 9 |
| | 1.1 General safety notes | 9 |
| | 1.2 Electrical safety | 10 |
| | 1.3 Correct usage | 11 |
| | 1.4 Safety of the machine or system..... | 12 |
| | 1.5 Safety when starting applications | 12 |
| | 1.6 Directives and standards | 13 |
| | 1.7 Documentation | 13 |
| | 1.8 Safety hotline..... | 13 |
| 2 | Product description..... | 15 |
| | 2.1 Structure of the PSR-RSM4..... | 15 |
| | 2.1.1 Operating elements | 16 |
| | 2.1.2 LEDs | 16 |
| | 2.2 Function description | 17 |
| 3 | Mounting..... | 19 |
| | 3.1 General..... | 19 |
| | 3.2 Mounting the PSR-RSM4 | 19 |
| 4 | Connection and wiring | 21 |
| | 4.1 General..... | 21 |
| | 4.2 RJ45 programming and encoder connection..... | 21 |
| | 4.2.1 Signal conditioning for HTL encoders | 22 |
| | 4.3 Initiator connection | 23 |
| | 4.4 Adaptation to existing drive systems | 25 |
| | 4.5 Connection for the supply voltage | 26 |
| | 4.6 Start circuit connection | 26 |
| | 4.7 Operating mode selection..... | 27 |
| | 4.8 Switching outputs | 27 |
| | 4.8.1 Signal outputs | 29 |
| 5 | Software installation..... | 31 |
| | 5.1 System requirements..... | 31 |
| | 5.2 Installation instructions | 31 |
| | 5.3 Program startup..... | 34 |

PSR-CONF-WIN

| | | |
|-----------|--|-----------|
| 6 | Parameterization..... | 35 |
| 6.1 | Toolbar for parameterization..... | 35 |
| 6.1.1 | Language selection | 37 |
| 6.1.2 | Refresh button | 37 |
| 6.2 | Input fields for the parameterization..... | 38 |
| 6.2.1 | Axis/Spindle | 38 |
| 6.2.2 | Machine | 38 |
| 6.2.3 | Axial pitch/Ratio | 39 |
| 6.2.4 | Encoder | 39 |
| 6.2.5 | Automatic operation | 40 |
| 6.2.6 | Special operation mode | 40 |
| 6.2.7 | Set mode | 40 |
| 6.2.8 | Stop mode | 40 |
| 6.2.9 | Error message output FO | 41 |
| 6.2.10 | Signal output MO1 | 41 |
| 6.2.11 | Signal output MO2 | 41 |
| 6.2.12 | IN/RJ45 | 42 |
| 6.2.13 | Encoder type | 42 |
| 6.3 | Parameterization of shaft break monitoring | 43 |
| 7 | Startup | 45 |
| 7.1 | Communication with the module..... | 45 |
| 7.2 | Hardware connection | 45 |
| 8 | System response times | 47 |
| 9 | Safety evaluation of connected measuring systems | 49 |
| 9.1 | Requirements for subsystems when using different sensors | 50 |
| 10 | Error detection | 51 |
| 10.1 | Initiator errors, data errors | 51 |
| 10.2 | Encoder errors..... | 51 |
| 10.3 | Error list | 52 |
| 11 | Application examples..... | 53 |
| 11.1 | Application 1: basic machine | 53 |
| 11.2 | Application 2: basic machine with a monitored drive | 54 |
| 11.3 | Application 3: machine tool with several drives and differentiated operating modes | 55 |
| 11.4 | Application 4: basic machine with monitored drive and additional drive shaft monitoring..... | 56 |

Table of contents

| | | |
|------|--|----|
| 12 | Technical data and ordering data | 57 |
| 12.1 | Technical data | 57 |
| 12.2 | Ordering data | 59 |
| A | Appendix for document lists..... | 61 |
| A 1 | List of figures | 61 |
| A 2 | List of tables | 63 |
| B | Revision history | 65 |

PSR-CONF-WIN

1 For your safety

Purpose of this user manual

The information in this document is designed to familiarize you with how the PSR-RSM4 safety module works, its operating and connection elements, and its parameter settings. This information will enable you to use the safety module according to your requirements.

Validity of the user manual

This user manual is only valid for the safety modules indicated on the inner cover page.

1.1 General safety notes



WARNING: Incorrect handling can pose serious risks for the user

Depending on the application, incorrect handling of the safety module can pose serious risks for the user.

- When working with the safety module, please observe all the safety notes included in this section.

Qualified personnel

In terms of this user manual, qualified personnel are persons who, because of their education, experience and instruction, and their knowledge of relevant standards, regulations, accident prevention, and service conditions, have been authorized to carry out any required operations, and who are able to recognize and avoid any possible dangers.

Safety of personnel and equipment

The safety of personnel and equipment can only be assured if the safety module is used correctly (see "Correct usage" on page 11).

Error detection

Depending on the wiring and the corresponding setting of the parameters, the PSR-RSM4 can detect various errors.

Ground contact

Please ensure that all inputs and outputs and the safety switching device are connected to the same ground.

Do not carry out any repairs

Repair work may not be carried out on the safety module.

In the event that an error cannot be removed, please contact Phoenix Contact immediately, engage a service engineer or send the faulty module directly to Phoenix Contact.

Do not open the housing/security seal

It is strictly prohibited to open the safety module housing. In order to prevent the manipulation of the safety module and to detect the unauthorized opening of the safety module, a security seal is applied to the module. This security seal is damaged in the event of unauthorized opening. In this case, the correct operation of the safety module can no longer be ensured.

Measures to prevent mismatching and polarity reversal

Take measures to prevent the mismatching, polarity reversal, and manipulation of connections.

1.2 Electrical safety



WARNING: Hazardous shock currents and the loss of Functional Safety

Disregarding instructions for electrical safety may result in hazardous shock currents and the loss of Functional Safety.

- In order to ensure electrical safety, please observe the following points.

Direct/indirect contact

Protection against direct and indirect contact according to VDE 0100 Part 410 must be ensured for all components connected to the system. In the event of an error, parasitic voltages must not occur (single-fault tolerance).

This can be achieved by:

- Using power supply units with safe isolation (PELV)
- Decoupling circuits, which are not PELV systems, using optocouplers, relays, and other components which meet the requirements of safe isolation

Power supply unit for 24 V supply

Only use power supply units with safe isolation and PELV according to EN 50178/VDE 0160. This prevents short-circuits between primary and secondary sides.

Make sure that the output voltage of the power supply does not exceed 32 V even in the event of an error.

PELV

PELV = Protective extra-low voltage according to EN 50178/VDE 0160

Insulation rating

When selecting the equipment, please take into consideration the dirt and surge voltages which may occur during operation.

The PSR-RSM4 safety module is designed for surge voltage category II (according to DIN EN 60664-1). If you expect surge voltages in the system, which exceed the values defined in surge voltage category II, take into consideration additional measures for voltage limitation.



WARNING: Incorrect installation and upgrades can pose serious risks for the user

Depending on the application, incorrect installation and upgrades can pose serious risks for the user.

The user is obliged to design the devices used and their installation in the system according to these requirements.

- Check plants and systems retrofitted with the PSR-RSM4 safety module in this respect.

1.3 Correct usage

Only use the PSR-RSM4 safety module in accordance with the instructions in this section.

The PSR-RSM4 safety module is designed exclusively for downtime and speed monitoring on machines and systems.

The safety module can only perform its safety-related tasks within the system if it has been integrated into the execution process correctly and in such a way as to avoid errors.

Within a system, the PSR-RSM4 safety module can be used to achieve safety functions with the following requirements depending on the conditions of use:

- Up to SIL 3 according to EN 61508
- Up to SILCL 3 according to EN 62061
- Up to Cat. 4/PL e according to EN ISO 13849-1

Key

| | |
|--------------|------------------------|
| SIL | Safety integrity level |
| SILCL | SIL claim limit |
| Cat. | Category |
| PL | Performance level |

The PSR-RSM4 safety module can be used, for example, in the following applications:

- Safety circuits according to EN 60204 Part 1
- Safe shutdown of contactors, motors (24 V DC), valves, ohmic, inductive, and capacitive loads



Before startup, configure the safety module according to your application. To do this, you will require the PSR-CONF-WIN parameterization software that is described in this user manual.

1.4 Safety of the machine or system

The machine/system manufacturer and the operator are solely responsible for the safety of the machine or system and the implemented application in which the machine or system is used. The Machinery Directive must therefore be observed.

Draw up and implement a safety concept

In order to use the safety module described in this document, you must have drawn up an appropriate safety concept for your machine or system. This includes a hazard and risk analysis according to the directives and standards specified in "Directives and standards" on page 13.

The target safety integrity level (SIL according to IEC 61508, SILCL according to EN 62061 or performance level and category according to EN ISO 13849-1) is ascertained on the basis of the risk analysis. The safety integrity level ascertained determines how to connect and parameterize the safety module within the overall safety function.

Safety-related equipment

In order to use the PSR-RSM4 properly, safety-related equipment must be provided on the machine.

This includes protective cover switches, enable switches, mode selector switches, and essential sensors for motion detection (e.g., rotary impulse encoders, length measuring systems, initiators, and Hall sensors).

The limit values may not be switched by the control circuit, as control circuits are generally not safety-related.

Check hardware and parameterization

Carry out a **validation** every time you make a safety-related modification to your overall system.

Use your test report to ensure that the following conditions are met:

- The safe devices are connected to the correct sensors and actuators.
- The safety functions have been wired correctly.
- The parameter settings have been correctly calculated and set according to the safety function.

1.5 Safety when starting applications

Take the following into consideration when determining the start conditions for your machine or system:

- The machine or system may only be started if it has been ensured that no one is present in the danger zone.
- Meet the requirements of EN ISO 13849-1 with regard to the manual reset function.

This applies to:

- Switching on safe devices
- Acknowledging device error messages
- Removing startup inhibits for safety functions

1.6 Directives and standards

The manufacturers and operators of machines and systems in which the PSR-RSM4 module is used are responsible for adhering to all applicable directives and legislation.

For the standards observed by the safety module, please refer to the certificate issued by the approval body and the EC declaration of conformity. These documents are available on the Internet at phoenixcontact.net/products.

1.7 Documentation

Latest documentation

Make sure you always use the latest documentation. Changes or additions to this document can be found on the Internet at phoenixcontact.net/products.

1.8 Safety hotline

24-hour hotline

Should you have any technical questions, please contact our 24-hour hotline.

Phone: + 49 5281 9-462777

E-mail: safety-service@phoenixcontact.com

PSR-CONF-WIN

2 Product description

2.1 Structure of the PSR-RSM4

Product image



Figure 2-1 Product image for the PSR-RSM4

Connection versions

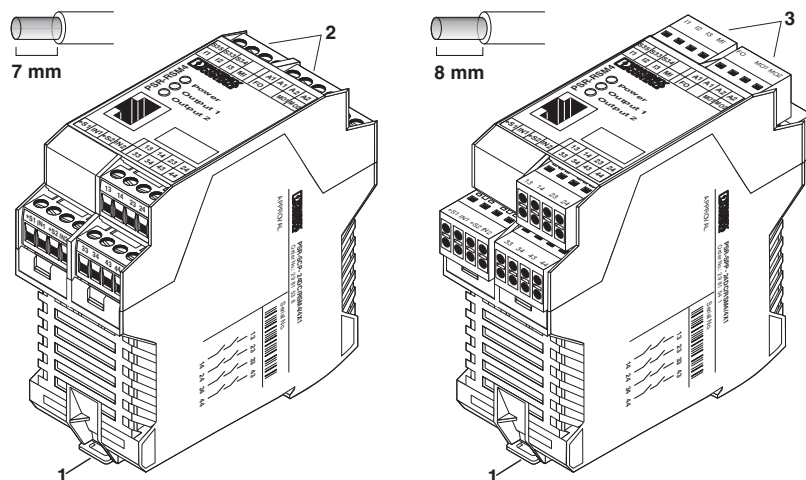

Figure 2-2 Connection versions for the PSR-RSM4

- 1 Metal lock for fixing to the DIN rail
- 2 COMBICON plug-in screw terminal block
- 3 COMBICON plug-in spring-cage terminal block

2.1.1 Operating elements

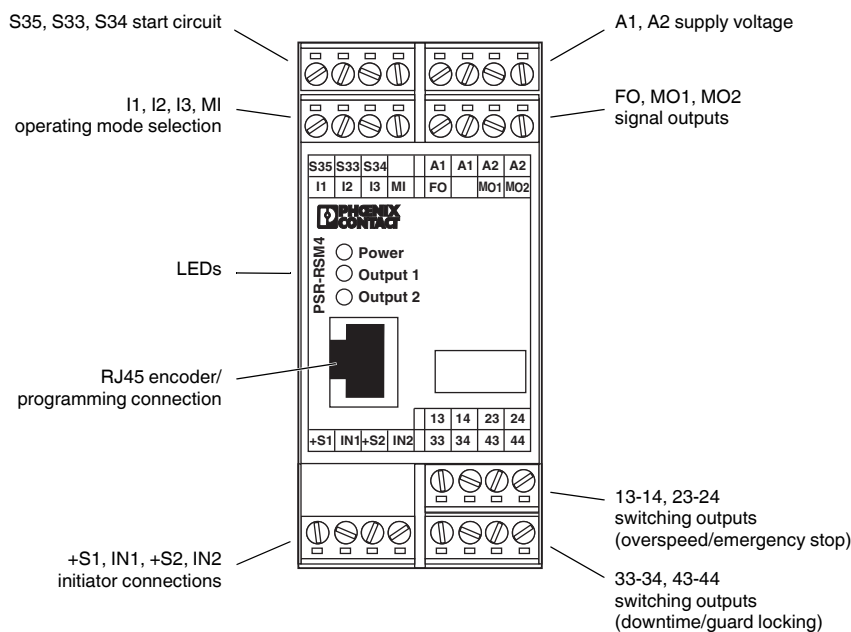





Figure 2-3 Operating elements of the PSR-RSM4

2.1.2 LEDs

- 
Power **Supply voltage**
 ON: speed monitor is ready
 Flashing: an error has occurred ("Error list" on page 52)
- 
Output 1 **Overspeed (emergency stop)**
 ON: actual speed (speed) < parameterized overspeed threshold
- 
Output 2 **Downtime detection**
 ON: actual speed (speed) < parameterized downtime threshold

2.2 Function description

Block diagram

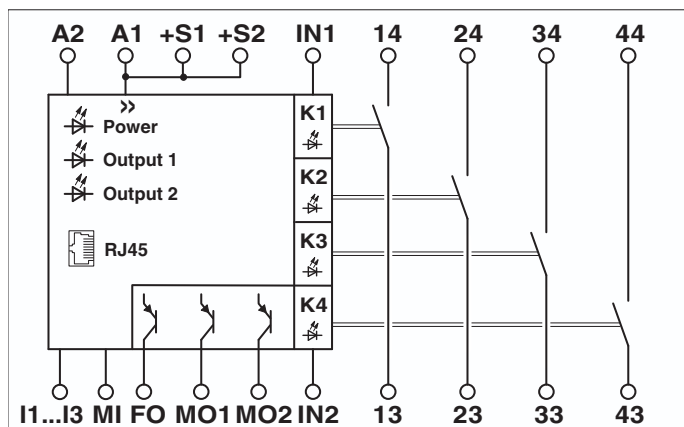

Figure 2-4 Block diagram for the PSR-RSM4

Key

| Designation | Explanation |
|---------------|--|
| A1, A2 | Supply voltage connection |
| +S1, IN1 | Initiator connections |
| +S2, IN2 | |
| I1 ... I3, MI | Operating mode selection |
| FO | Error message output |
| MO1 | Signal output (emergency stop) |
| MO2 | Signal output (guard locking) |
| 13-14, 23-14 | Switching outputs (overspeed/emergency stop) |
| 33-34, 43-44 | Switching outputs (downtime/guard locking) |
| RJ45 | Encoder input |

Method of operation

The speed monitor is used to monitor movement on all types of machines, assuming that the required equipment is present on the machine.

Motion detection is performed by two proximity switches which switch with an overlap or by an encoder (incremental or sin/cos encoder) that can be connected via a cable adapter.

The frequency comparator uses the actual value for speed detection and the setpoint for operating mode selection at I1, I2, I3 or MI to update the downtime contact and the speed/emergency stop contact (see Figure 2-5 "Function diagram").

PSR-CONF-WIN

Function diagram

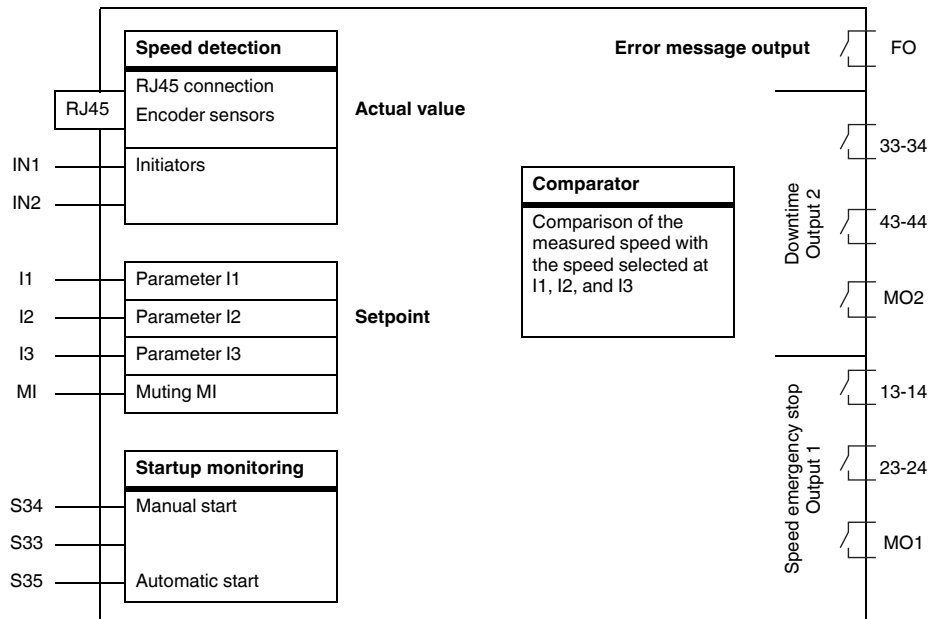

Figure 2-5 Function diagram

Function description

Once the operating voltage (24 V DC) has been applied at terminal blocks A1 and A2, the electronics (during downtime) check whether at least one proximity switch is supplying a signal to input IN1 or IN2 or whether a valid signal is present at the encoder input. If so, all the output relays switch to the operated condition, according to terminal blocks S33, S34, and S35. N/O contacts 13-14, 23-24 (emergency stop), and 33-34, 43-44 (guard locking) are closed, signal outputs MO1 (emergency stop) and MO2 (guard locking) supply 24 V DC. Error message output FO is in a high-resistance state.

Outputs 33-34 and 43-44 (guard locking) remain active in their switch position as long as no signal change is generated at the inputs (IN1 and IN2 or at the encoder input) by a movement greater than the parameterized downtime frequency. As soon as the downtime frequency is exceeded, outputs 33-34 and 43-44 return to the idle position and signal output MO2 switches to a high-resistance state.

Outputs 13-14 and 23-24 (emergency stop) remain active in their switch position as long as the parameterized and preselected desired speed value is not exceeded at the inputs (IN1 and IN2 or at the encoder input). As soon as the desired speed value is exceeded, outputs 13-14 and 23-24 return to the idle position and signal output MO1 switches to a high-resistance state.

If an initiator or encoder error is detected, all the output relays shut down, the "Power" LED flashes, and error message output FO supplies 24 V.

Signal outputs MO1 and MO2 and error message output FO can be inverted via the PSR-CONF-WIN software.

3 Mounting

3.1 General

The module is supplied in an ESD box together with a package slip with installation instructions.

Please read the complete package slip carefully.



NOTE: Electrostatic discharge

The module contains components that can be damaged or destroyed by electrostatic discharge. When handling the module, observe the necessary safety precautions against electrostatic discharge (ESD) according to EN 61340-5-1 and IEC 61340-5-1.

Qualified personnel

The safety module may only be installed and removed by qualified personnel.



WARNING: Unintentional machine startup

The system may only be started provided neither the station nor the system poses a hazard.

- Do not mount or remove the module while the power is connected.
- Before mounting or removing the safety module, disconnect the power to the module and ensure that it cannot be switched on again.
- Make sure the entire system is reassembled before switching the power back on.
- Observe the diagnostics indicators and any diagnostic messages.

Installation space

To ensure reliable operation, install the safety module in housing protected from dust and humidity (IP54 or higher).

In order to prevent manipulation, secure the housing (control cabinet/control box) against being opened by unauthorized persons.

Mount the safety module on a 35 mm DIN rail.

3.2 Mounting the PSR-RSM4

- Disconnect the power to the station.
- Hold the safety module perpendicular and snap it onto the DIN rail (7.5 mm in height).



Observe a mounting distance of 30 mm above and 40 mm below the safety module. Shorter distances may inhibit proper handling during installation.

- Check that all the snap-on mechanisms are securely snapped into place.



Make sure that all featherkeys and keyways on adjacent terminals are securely interlocked.

PSR-CONF-WIN

4 Connection and wiring

4.1 General

Qualified personnel

The electrical connection, startup, and operation of this device may only be performed by qualified personnel.



WARNING: Unintentional machine startup

The system may only be started provided neither the station nor the system poses a hazard.

- Make sure the entire system is reassembled before switching the power back on.
- Observe the diagnostics indicators and any diagnostic messages.

4.2 RJ45 programming and encoder connection



The RJ45 input is only designed for programming and for TTL, HTL, and sine/cosine encoders.

Resolver encoder, Ethernet or ISDN signals will not be processed.

Programming

The safety module is connected to the computer for configuration via the RS-232 programming cable. The cable is a passive interface cable with RJ45 and D9-SUB connector plug.

- Use this interface cable to connect the speed monitor to a free COM interface on the PC.

| Signal | D9-SUB | Signal | RJ45 |
|--------|--------|--------|------|
| | RS-232 | | PIN |
| | PIN | | |
| – | 1 | GND | 1 |
| TX | 2 | – | 2 |
| RX | 3 | – | 3 |
| – | 4 | – | 4 |
| GND | 5 | RX | 5 |
| – | 6 | – | 6 |
| – | 7 | TX | 7 |
| – | 8 | – | 8 |
| – | 9 | | |

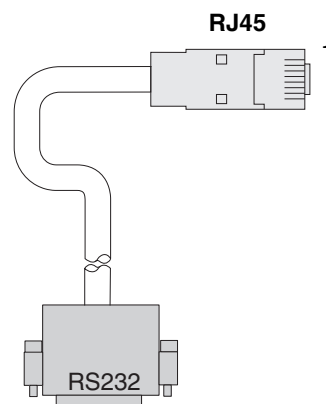

Figure 4-1 Interface cable with RJ45 and D9-SUB connector plug

Encoder connection

- Connect the encoder to the front of the device using an RJ45 adapter cable (accessory).

Cut-off frequency: 400 kHz

Nominal input voltage: 1 V_{PP}, 5 V TTL, and 24 V HTL

PSR-CONF-WIN



The supply voltage of the encoder is not provided by the PSR-RSM4 and must therefore be supplied separately.



NOTE: Errors

The GND connection of the encoder must be connected to the GND connection (pin 1 of the RJ45 connector).

- Follow the encoder manufacturer's recommendations to ensure correct shielding of the sensor cable.

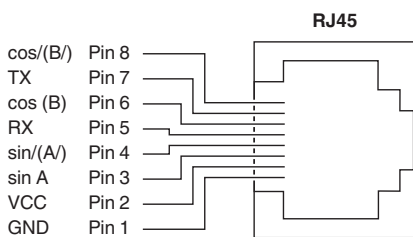

Figure 4-2 Connection with RJ45 connector

The Sin(A), Sin/(A/), Cos(B), and Cos/(B/) signals must be present. Encoders without negated tracks cannot be used.

4.2.1 Signal conditioning for HTL encoders

Signal conditioning is required if the permissible low level of the encoder signals of 0.8 V is exceeded.

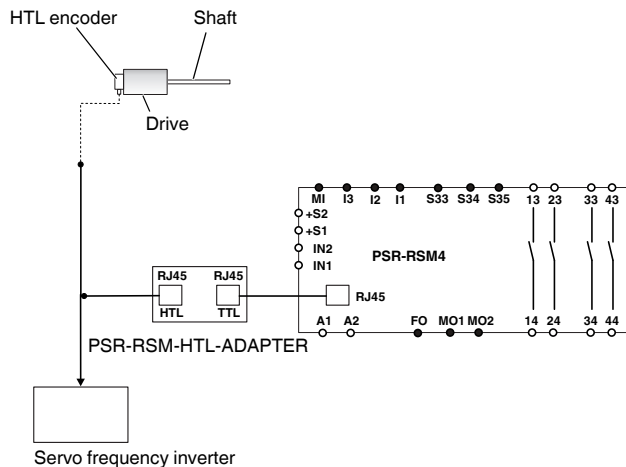

Figure 4-3 Connection example



Signal conditioning may be required if HTL encoders are used. Use the PSR-HTL adapter from Phoenix Contact for this (Order No. 2981897).

4.3 Initiator connection

IN1, IN2

24 V two or three-wire sensors can be connected directly to the plug-in connection terminal blocks.



WARNING: Loss of Functional Safety

Cross-circuits between the initiators can result in the loss of Functional Safety.

- Prevent cross-circuits between the initiators by using a suitable cable installation.

Cut-off frequency: 2 kHz

Nominal input voltage: 24 V HTL

Single-channel operation

- In single-channel operation, jumper IN1 and IN2.



WARNING: Loss of Functional Safety

In single-channel operation, sensor errors and an open circuit or short-circuit of the sensor cable are not detected by the safety module.

+S1, +S2

Two and three-wire sensors can be supplied directly by the safety module via terminal blocks +S1 and +S2 ($U_N = 24 \text{ V DC}$).

For three-wire sensors, please note that the GND potential of the sensors is the same as the device potential of the PSR-RSM4.



To prevent electromagnetic interference, the initiator cables that are installed must be shielded.

Requirements for a gear wheel or gear rack

The design of the gear wheel or the gear rack is an important factor for safe operation.

The gear wheel surface must always be larger than the gap between the teeth. This ensures that at least one initiator is dampened.

Requirements for the initiators

- Tooth > tooth gap
- Tooth > switch diameter
- Gap depth > switch operating distance
- $a \leq (\text{switch operating distance}/2)$ (as per manufacturer's information))

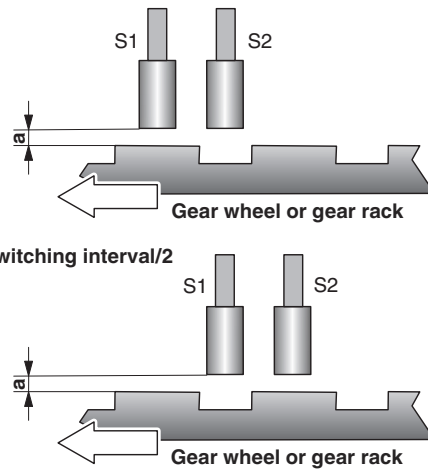

Figure 4-4 Mounting initiators

4.4 Adaptation to existing drive systems

Prefabricated Y cable adapters can be used on existing drive systems for quick and easy connection. Phoenix Contact offers an appropriate solution for all popular systems (see Table 4-1).

The Y adapter is inserted directly into the motor feedback interface (D-SUB or other) and connects the encoder (or sin/cos encoder) to the drive and the PSR-RSM4 (Figure 22).

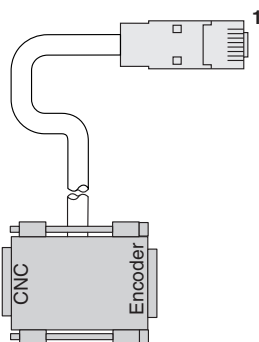

Figure 4-5 Y adapter

Table 4-1 Adaptation to existing drive systems

| Order No. | Designation | D-SUB | Controller type | Motor feedback - interface (D-SUB) assignment | | | | | | RJ45 assignment | | | | | | |
|-----------|-------------------------------|-------------|---------------------|---|----|----|----|----|----|-----------------|----|---|----|---|----|---|
| | | | | UB | 0V | A | A/ | B | B/ | UB | 0V | A | A/ | B | B/ | |
| 2981583 | CABLE-25/8/250/RSM/SIMO611D | D-SUB 25 | Siemens, Heidenhain | 1 | 2 | 3 | 4 | 6 | 7 | 2 | 1 | 3 | 4 | 6 | 8 | |
| 2981596 | CABLE-25/8/250/RSM/ARADEx | | Aradex | 1 | 12 | 2 | 3 | 4 | 5 | | | | | | | |
| 2981606 | CABLE-15/8/250/RSM/SIMO611D | | Siemens, Heidenhain | 1 | 2 | 3 | 4 | 6 | 7 | | | | | | | |
| 2981619 | CABLE-15/8/250/RSM/MHD/G | D-SUB 15 | Indramat | 12 | 4 | 2 | 9 | 3 | 10 | | | | | | | |
| 2981622 | CABLE-15/8/250/RSM/SIN800 | | Siemens | 14 | 11 | 1 | 9 | 10 | 3 | | | | | | | |
| 2981635 | CABLE-15/8/250/RSM/FM-NC | | Siemens | 4 | 9 | 15 | 14 | 13 | 12 | | | | | | | |
| 2981648 | CABLE-15/8/250/RSM/DKC | | Indramat | 12 | 10 | 7 | 8 | 6 | 5 | | | | | | | |
| 2981651 | CABLE-15/8/250/RSM/AMK | | AMK | 7 | 8 | 4 | 3 | 6 | 5 | | | | | | | |
| 2981664 | CABLE-15/8/250/RSM/SWE-X15 | | SEW | 15 | 8 | 2 | 10 | 1 | 9 | | | | | | | |
| 2981758 | CABLE-15/8/250/RSM/PD | | Parker Drives | 4 | 2 | 1 | 9 | 3 | 11 | | | | | | | |
| 2981826 | CABLE-9/8/250/RSM/LENZE | | D-SUB 9 | LENZE | 4 | 5 | 3 | 2 | 1 | | | | | | | 9 |
| 2986698 | CABLE-15/8/250/RSM/KINETIX | | D-SUB 15 | AB KINETIX | 14 | 6 | 1 | 2 | 3 | | | | | | | 4 |
| 2986973 | CABLE-15/8/250/RSM/IHDUNI-SP | Unidrive SP | | - | 14 | 1 | 2 | 3 | 4 | | | | | | | |
| 2986986 | CABLE-15/8/250/RSM/INDRADYN-2 | Rexroth | | - | 4 | 2 | 3 | 5 | 6 | | | | | | | |
| 2986999 | CABLE-20/8/250/RSM/FANUC | FANUC | GE FANUC | 20 | 12 | 5 | 6 | 7 | 8 | | | | | | | |
| 2901746 | CABLE-25/8/250/RSM/E-SIMO611D | D-SUB 25 | Siemens, Heidenhain | 1 | 2 | 3 | 4 | 6 | 7 | | | | | | | |
| 2902338 | CABLE-15/8/250/RSM/INDEL | D-SUB 15 | INDEL | 12 | 10 | 1 | 9 | 3 | 11 | | | | | | | |
| 2902984 | CABLE-9/8/250/RSM/ELAU | D-SUB 9 | ELAU | - | 9 | 1 | 2 | 3 | 4 | | | | | | | |
| 2904108 | CABLE-15/8/100/RSM/BM | D-SUB 15 | Baumüller | - | 1 | 8 | 7 | 5 | 9 | | | | | | | |

Further types available on request at phoenixcontact.net/products.

4.5 Connection for the supply voltage

A1, A2

The supply voltage must be between 20.4 V DC and 26.4 V DC ($U_N = 24 \text{ V DC}$).

- Connect the supply voltage to terminal points A1 and A2.

Connections A1 (24 V) and A2 (0 V) are arranged in pairs and each is jumpered internally.

The speed monitor is ready for operation as soon as the "Power" LED lights up.

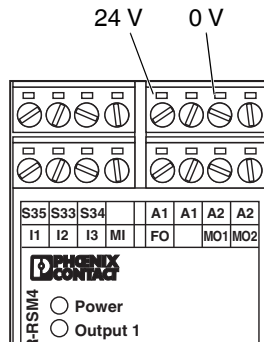

Figure 4-6 Connection for the supply voltage



The "Power" LED flashes in the event of an initiator/encoder error (see "Initiator errors, data errors" on page 51 and "Encoder errors" on page 51).

- In this case, check the initiator/encoder connection.

4.6 Start circuit connection

S33, S34, S35

- Connect the start circuit via terminal blocks S33, S34, and S35.

You can choose between automatic and manual start.

Automatic start

- Jumper S33 and S35.



WARNING: Risk of automatic machine restart

The system may only be started provided neither the station nor the system poses a hazard.

- The machine must be prevented from restarting automatically by a higher-level controller.

Manual start with monitored edge

- Connect the start button to S33 and S34.

4.7 Operating mode selection

I1, I2, I3, MI

The parameters for the operating modes at the connection terminal blocks are specified via the PSR-CONF-WIN configuration software (see page 35).

Nominal input voltage: 24 V DC



WARNING: Loss of Functional Safety due to incorrect wiring

“Mute” mode (24 V DC at terminal block MI) disables speed monitoring. Contacts 13-14 and 23-24 are permanently in the operated condition.

- Check whether your wiring has been carried out correctly.

Priority of terminal blocks:

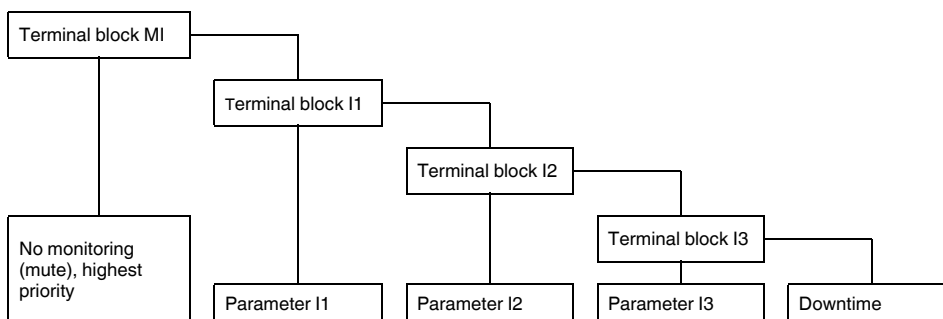

Figure 4-7 Priority of terminal blocks



Switching the inputs from a high priority to a lower priority (MI -> I3) is delayed by 500 ms. There is no delay when switching in the opposite direction.



If none of the input terminal blocks (MI, I1 - I3) are assigned, contacts 13-14 and 23-24 are monitored with the parameterized downtime speed.

4.8 Switching outputs

The safety-related switching outputs (13-14, 23-24, 33-34, and 43-44) are floating N/O contacts and are suitable for 250 V/5 A. They are connected via plug-in connection terminal blocks.

13-14, 23-24

Forcibly guided N/O contacts for evaluating overspeed (emergency stop)

As long as the parameterized and preselected speed is not exceeded, the N/O contacts are in the operated condition.

In the event of an overspeed, the contacts open and the relays are then in the idle position.



Reliable contact is achieved by connecting contacts 13-14 and 23-24 in series. Alternatively, the individual contacts can be integrated into the two-channel emergency stop circuit.

PSR-CONF-WIN

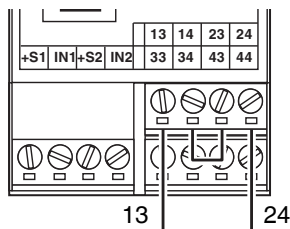

Figure 4-8 Connecting contacts 13-14 and 23-24 in series

33-34, 43-44

Forcibly guided N/O contacts for evaluating downtime

As long as the parameterized downtime speed is not exceeded, the N/O contacts are in the operated condition.

In the event that the downtime speed is exceeded, the contacts open and the relays are then in the idle position.



Reliable contact is achieved by connecting contacts 33-34 and 43-44 in series.

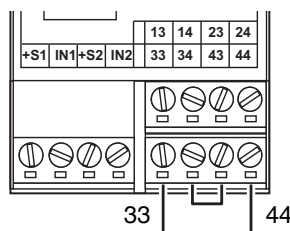

Figure 4-9 Connecting contacts 33-34 and 43-44 in series



The N/O contacts are **fixed** at the parameterized downtime speed. Operating mode inputs I1 ... MI have **no** effect on these contacts.

4.8.1 Signal outputs



WARNING: Loss of Functional Safety due to incorrect wiring

Error message output FO and signal outputs MO1 and MO2 are not safety-related.

- Do not use error message output FO and signal outputs MO1 and MO2 in a safety-related way.

The signal and error message outputs (MO1, MO2, and FO) are non-isolated, short-circuit-proof switching outputs and can support 24 V DC/100 mA.

They are parameterized as NPN or PNP mode via the PSR-CONF-WIN configuration software (see 6.2.10 and 6.2.11).

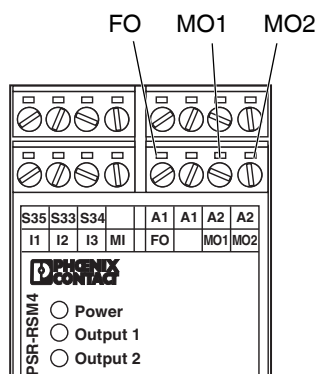

Figure 4-10 Connecting the signal and error message outputs

FO

Error message output

In the event of an error (e.g., encoder error, cable break or internal failure), a static signal is output (see “Error message output FO” on page 41).

MO1

Overspeed signal output

In the event of an overspeed, a static signal is output (see “Signal output MO1” on page 41).

MO2

Downtime signal output

In the event of a downtime, a static signal is output (see “Signal output MO2” on page 41).

PSR-CONF-WIN

5 Software installation

5.1 System requirements

Any computer with a free RS-232 interface can be connected to the PSR-RSM4 safety module.

A PC with one of the following operating systems is required for the PSR-CONF-WIN configuration software and the Plug and Play function:

- Windows XP
- Windows 7 (32-bit)

The application program is supplied on an installation CD. The technical documentation can be opened directly in the application program.

5.2 Installation instructions

- Insert the CD-ROM labeled “PSR-CONF-WIN” in the CD-ROM drive on your computer.
- Use Windows Explorer to start the “Setup.exe” file located in the setup directory.



Figure 5-1 Installation start screen

- Click on “Next”.

PSR-CONF-WIN

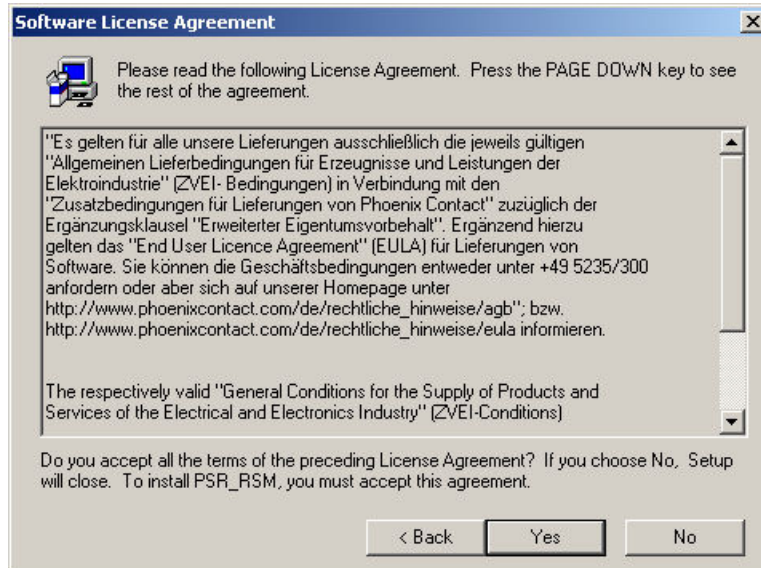

Figure 5-2 Software license terms

- To accept the terms of the license agreement, confirm with "Yes".

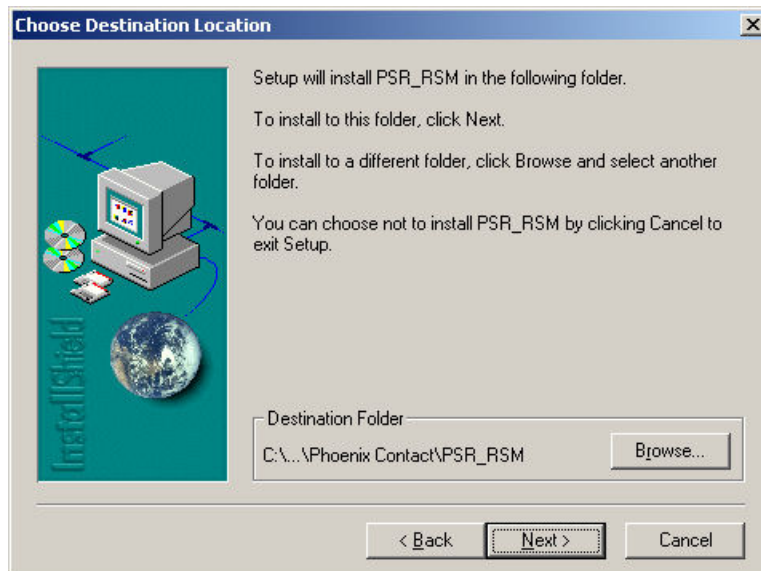

Figure 5-3 Selecting the installation directory

- Select an installation directory and click on "Next".

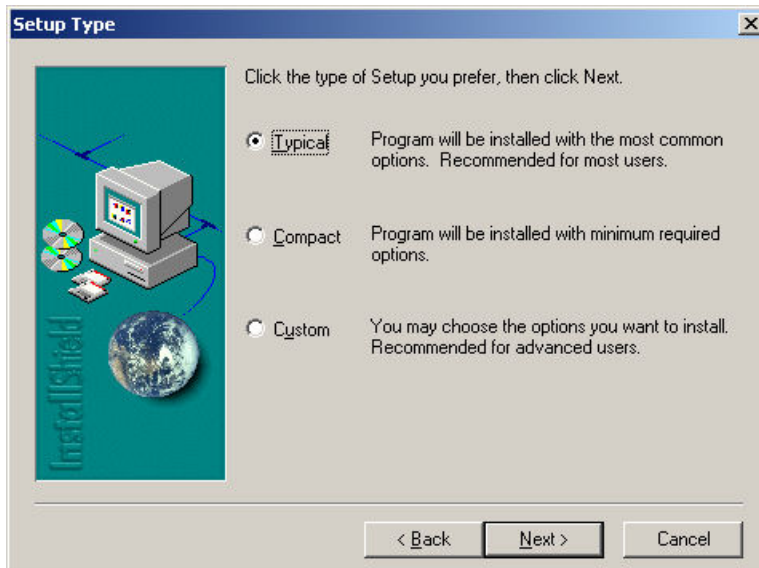

Figure 5-4 Selecting the type of installation

- Select "Typical" and confirm with "Next".

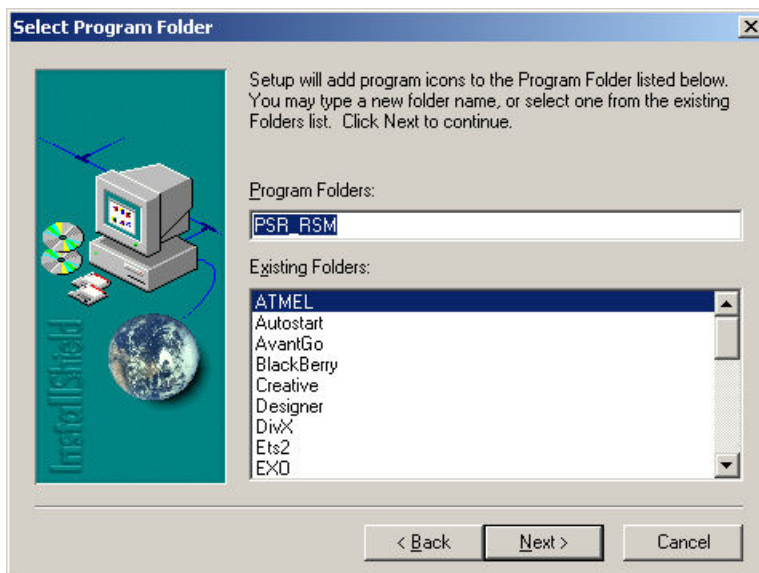

Figure 5-5 Selecting the program name for the Start menu

- Select a name for the entry in the Start menu and confirm with "Next".

PSR-CONF-WIN

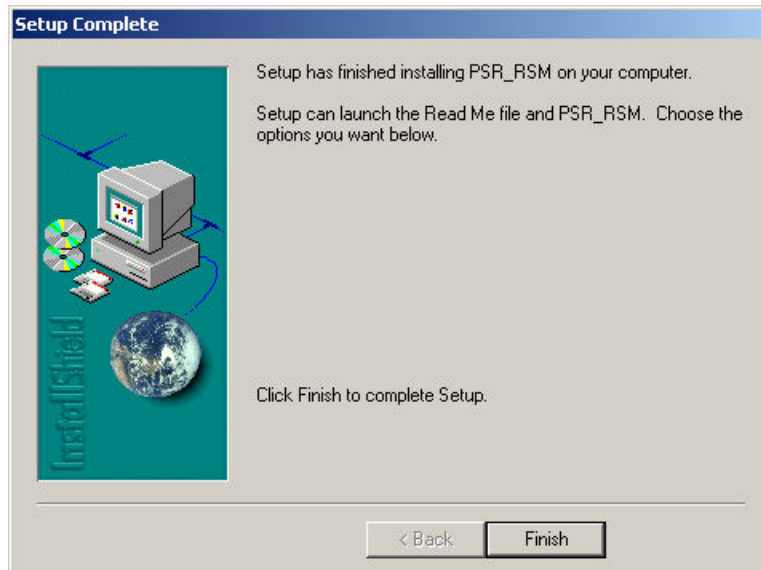

Figure 5-6 Completing the installation

- To complete the installation, click on "Finish".

5.3 Program startup

After installation the following shortcut will appear on your desktop:



Figure 5-7 Desktop shortcut

The program can be started via the shortcut or via the Windows Start menu.

6 Parameterization





6.1 Toolbar for parameterization



Figure 6-1 Start screen of the parameterization software

The toolbar and the functions of the individual buttons are described below.

Table 6-1 Toolbar for parameterization

| Button | Designation | Explanation |
|---|-------------------|--|
|  | New | Corresponds to a program restart. All existing entries are deleted. Deleted forms cannot be restored. |
|  | Open file | Load an existing file. The extension .phx is selected by default. The loaded data is displayed immediately. A previously created application that was not saved is overwritten when a file is loaded. The loaded file is displayed in the toolbar. |
|  | Save file | Save a created application. The extension .phx is selected by default. A prompt is displayed if an existing file name is selected. |
|  | Print file | Print the displayed parameters for the system documentation. The parameter record must be saved first. |

PSR-CONF-WIN

Table 6-1 Toolbar for parameterization













| Button | Designation | Explanation |
|---|--------------------------------|---|
|  | Data upload | <p>The PSR-RSM4 module parameters are transferred to the computer via the data cable. The data is displayed immediately. A password is not required.</p> <p> The module disables the outputs during communication.</p> |
|  | Data download | <p>The created application is transferred from the computer to the PSR-RSM4 via the data cable. This feature is password-protected. Before downloading the data, establish a connection between the computer and the PSR-RSM4 using the data cable.</p> <p>Enter your user name (6 - 32 characters) together with the password.</p> <p>If the password is not entered correctly, the data will not be transferred to the device.</p> <p> The module disables the outputs during communication.</p> |
|  | Program info | Info box containing data and the software version. |
|  | History | Following a data upload, the firmware version, user name, date, and time of the last transfer are displayed. |
|  | Technical documentation | The technical documentation (.pdf file) is opened in the set language. |
|  | COM port | The COM port must be specified prior to transfer. The settings are saved in an .ini file when exiting the program and are reloaded the next time the program is started. COM port 1 is set by default. |

Table 6-1 Toolbar for parameterization

| Button | Designation | Explanation |
|---|---------------------------|--|
|  | Change password | <p>The password can be changed. Default: "00000000" (eight zeros).</p> <p>Before changing the password, establish a connection between the computer and the PSR-RSM4 using the data cable.</p> <div style="border: 1px solid black; padding: 5px; margin-top: 10px;">  The module disables the outputs during communication. </div> |
|  | Language selection | <p>German, English, French, Spanish, and Italian can be selected.</p> <p>The language can also be selected directly in the program interface. Click on the corresponding button:</p> <div style="text-align: center; margin-top: 10px;">  </div> |
|  | Exit | Exit the program. A prompt to save the data is displayed. |

6.1.1 Language selection

The software language can be selected via the relevant country abbreviation.



The following are available:

German (DE), English (EN), French (FR), Spanish (ES), and Italian (IT).



The language can also be selected via this button in the toolbar.

6.1.2 Refresh button



When the Refresh button is selected, the program calculates the real frequency to be monitored in Hz according to the encoder and the set speed. The optimized values for the real monitored speed overwrite the values entered (tolerance < 1.3%).

The frequency value in Hz is displayed for three seconds.

6.2 Input fields for the parameterization



Figure 6-2 Start screen of the parameterization software

The input fields are described below.

6.2.1 Axis/Spindle

The calculation algorithms differ for rotary (Spindle) and linear (Axis) movements. The fields in the input mask change when “Axis”/“Spindle” is selected.

If the setting is changed during parameterization, the non-active data is deleted.

6.2.2 Machine

The “Machine” field is a text field for entering a name with a maximum of 16 characters, e.g., the machine designation. Although not mandatory, it is useful to enter a name. Letters, numbers, and special characters can be used.

6.2.3 Axial pitch/Ratio

The axial pitch must be specified for the axis. It indicates the feed rate of the axis in millimeters for one rotation.

The axial pitch can only be specified for axes, whereas the ratio can be specified for both axes and spindles.

The "Ratio" field describes the ratio of the encoder (encoder or sensor(s)) to the hazardous movement. The value for the encoder is fixed at "1".



Convert a ratio of, e.g., "4:3" into a corresponding ratio of "1:0.75".

Entries that are not integers are entered using dotted notation – e.g., "1.4".

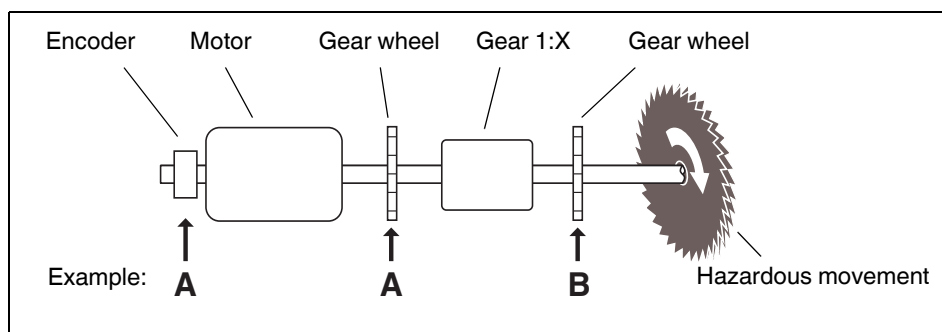

Figure 6-3 Ratio example

Example A: The value "1:X" must be entered for the ratio.

Example B: As speed detection depends on the gear, the ratio is 1:1.

6.2.4 Encoder

The encoder resolution can be specified in impulses per rotation.

Standard encoders can be found in the table. Resolutions that are not available can be entered directly in the input field.

For proximity switches, the number of cams per rotation is specified in the input field.

6.2.5 Automatic operation

The "Automatic operation" parameter is assigned to terminal block I1. The parameterized values can be achieved when terminal block I1 (+24 V DC) is selected.

Terminal block I1 has priority over I2 and I3.



Due to the control behavior of the motors, it is advisable to add an extra 10% to the maximum speed.

It is not possible to monitor movement to zero. The minimum frequency that can be set is 1.3 Hz.

6.2.6 Special operation mode

The "Special operation mode" parameter is assigned to terminal block I2. The parameterized values can be achieved when terminal block I2 (+24 V DC) is selected.

Terminal block I2 has priority over I3.



Due to the control behavior of the motors, it is advisable to add an extra 10% to the maximum speed.

It is not possible to monitor movement to zero. The minimum frequency that can be set is 1.3 Hz.

6.2.7 Set mode

The "Set mode" parameter is assigned to terminal block I3. The parameterized values can be achieved when terminal block I3 (+24 V DC) is selected.



Due to the control behavior of the motors, it is advisable to add an extra 10% to the maximum speed.

It is not possible to monitor movement to zero. The minimum frequency that can be set is 1.3 Hz.

6.2.8 Stop mode

If there is no signal present at terminal blocks I1, I2, I3 or MI, the PSR-RSM4 safety module monitors the application with the parameterized stop mode value. The value is evaluated via terminal blocks 13-14 and 23-24.

Irrespective of this, the parameter also acts as the switching threshold for the relay contacts at terminal blocks 33-34 and 43-44.

Due to possible drive synchronization fluctuations a restart hysteresis of 10% is observed. The parameterized value corresponds to the upper limit of the hysteresis.



It is not possible to monitor downtime to zero. The minimum frequency that can be set is 1.3 Hz.

6.2.9 Error message output FO

In the event of a sensor error or internal failure, the error message output is updated. Output FO is controlled according to the table.

| Parameter | npn | pnp | Power LED |
|-----------|----------|----------|-----------|
| No error | FO: 24 V | FO: 0 V | On |
| Error | FO: 0 V | FO: 24 V | Flashing |

6.2.10 Signal output MO1

Signal output MO1 is controlled according to contacts 13-14 and 23-24 (overspeed/emergency stop).

| Parameter | npn | pnp | Output 1 LED |
|---------------------|-----------|-----------|--------------|
| Output 13-24 closed | MO1: 24 V | MO1: 0 V | On |
| Output 13-24 open | MO1: 0 V | MO1: 24 V | Off |

6.2.11 Signal output MO2

Signal output MO2 is controlled according to contacts 33-34 and 43-44 (downtime detection).

| Parameter | npn | pnp | Output 2 LED |
|---------------------|-----------|-----------|--------------|
| Output 33-44 closed | MO2: 24 V | MO2: 0 V | On |
| Output 33-44 open | MO2: 0 V | MO2: 24 V | Off |

6.2.12 IN/RJ45

The following sensor versions are available:

IN1

Single-channel speed monitoring with a proximity switch

- Jumper IN1 and IN2.



WARNING: Loss of Functional Safety

In single-channel operation, sensor errors and an open circuit or short-circuit of the sensor cable are not detected by the safety module.

IN1,IN2

Speed monitoring with two proximity switches at IN1,IN2

The high signals at IN1 and IN2 must overlap. During downtime, at least one proximity switch must be dampened.

RJ45

Frequency measurement at the RJ45 input

See section for RJ45 assignment.

RJ45+IN1

Shaft break monitoring

- For shaft break monitoring, connect an initiator to IN1 in addition to the encoder.

The frequency is measured via the RJ45 input. The values for the encoder should be parameterized accordingly in the software. The measured frequency is verified via the initiator.

- Jumper IN1 and IN2.

See "Parameterization of shaft break monitoring" on page 43.

6.2.13 Encoder type

In "RJ45" and "RJ45+IN1" mode:

- Select the "Sin/Cos" encoder type for a sine/cosine encoder and "HTL/TTL" for the corresponding HTL or TTL encoder.

6.3 Parameterization of shaft break monitoring

The PSR-RSM4 speed monitor can be used to monitor a shaft for breaks. The following should be observed.

Encoder connection:

- Connect the encoder to the speed monitor via an adapter cable.
- Connect a gear wheel initiator to IN1.
- Jumper IN1 and IN2.

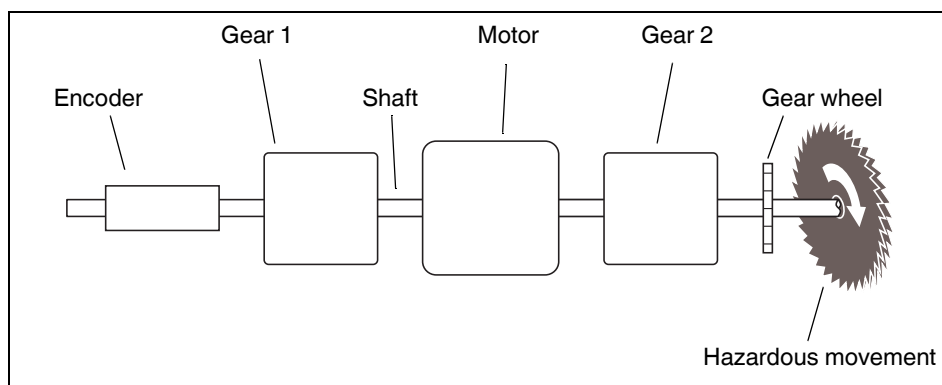

Figure 6-4 Shaft break monitoring

Software configuration:

- Enter the encoder values accordingly.
- Select the “RJ45 + IN1” sensor version.
- Enter the operating modes with maximum speeds.
- Calculate the corresponding downtime speed.

Formula for calculating the downtime speed according to the encoder and the number of teeth on the gear wheel:

$$n_{\text{Downtime}} \geq \frac{f_{\text{Gear wheel}}}{T \times R_2} \times \frac{60 \text{ s}}{\text{min}}$$

Key

| | |
|-------------------------|--|
| n_{Downtime} | Minimum downtime speed to be parameterized |
| $f_{\text{Gear wheel}}$ | Impulse frequency on the gear wheel in Hz (≥ 1 Hz) |
| Z | Number of teeth on the gear wheel |
| R_2 | Transformation ratio between motor and gear wheel (gear 2) |



Shaft break monitoring is only active after the downtime frequency has been exceeded (measured at the encoder input).

If the condition for shaft break monitoring is met (frequency at encoder input > downtime), the expected minimum frequency at the initiator input is 1 Hz.

When a movement is measured at the initiator input (IN1/IN2), a movement is likewise expected at the encoder input.

PSR-CONF-WIN

7 Startup

7.1 Communication with the module

1. Apply the operating voltage (24 V DC) at A1/A2.
2. Connect the module to a serial COM port via the programming cable.
3. Select the connected COM port in the software (see "COM port" on page 36).
4. Load the parameterized data to the module (see "Input fields for the parameterization" on page 38).
5. Enter the user name and password in the window.



Default password: "00000000" (eight zeros).

If the password is not entered, the data will not be transferred.

6. Once entered, the values must be verified again by the user. The values read back are displayed in a window. Check that they are correct and confirm with "Yes".
7. The values are only enabled on the module once they have been confirmed.



If data is not confirmed, the values are transferred but not enabled. The module remains inactive and indicates an error via the flashing Power LED.



If an encoder error is detected following transfer, the module enters the error state. It can only be started when the correct encoder signal is present.

7.2 Hardware connection

Make sure that the following requirements are met on the input side:

1. The sensors for motion detection are connected.
2. The maximum speed is selected at operating mode inputs I1, I2, I3, and MI.
3. Startup monitoring (S33/S34) is acknowledged or a jumper is present at (S33/S35).

If the requirements are met, the frequency comparator uses this information to generate the status information for the following:

4. Downtime contacts 33-34 and 43-44 with assigned signal output MO2
and
5. Speed/emergency stop contacts 13-14 and 23-24 with assigned signal output MO1

The parameters for the operating modes at I1, I2, I3, and MI are transferred to the PSR-RSM4 safety module via the configuration software.

PSR-CONF-WIN

8 System response times



When starting up safety equipment, verify that a safety-related output is disconnected within a maximum permissible response time if the input signal changes at the corresponding input.

Calculate the total duration of your planned application to verify the required response time.

The response time of the PSR-RSM4 is determined from the sum of the following factors:

1. Speed monitoring response time (PSR-RSM4 logic)
This time depends on the measured movement (frequency) and decreases linearly as the speed to be monitored increases. It is approximately 500 ms at 6 Hz. The minimum value of 30 ms is reached at 100 Hz and above.
2. Output relay release time (12 ms)

PSR-CONF-WIN

9 Safety evaluation of connected measuring systems

For the safety assessment of the overall arrangement and the associated measures to determine the safety integrity level achieved, the manufacturer's information must be consulted. This is why you should preferably use sensors where the safety-related properties have been certified by the manufacturer.

In general, the safety level of the sensor must correspond to the minimum target safety level of the overall arrangement (of the subsystem).

If using a single sensor, measures may need to be taken in some circumstances to avoid mechanically-caused errors (with at least one form of error prevention for the mechanical actuation chain).

Performance level PL e can be achieved with the PSR-RSM4 depending on the wiring (including the sensor and actuator system). You should always check your actual application to ascertain the level of safety that can be achieved.



Phoenix Contact recommends using the SISTEMA software utility to determine the achievable safety.

The SISTEMA software utility for the safety of control systems on machines can be downloaded free of charge from the website of the Institute for Occupational Safety and Health of the German Social Accident Insurance, see:

<http://www.dguv.de/dguv/ifa/Praxishilfen/Software/SISTEMA/index-2.jsp>

Observe the relevant guidelines of standards EN ISO 13849-1 and EN ISO 61800-5-2.

9.1 Requirements for subsystems when using different sensors

Inspection according to EN ISO 13849-1

Table 9-1 Connection of two proximity switches

| | |
|---|---|
| Basic safety principles | Must be used |
| Proven safety principles | Must be used |
| Additional requirements for systematic aspects | Must be met (see EN ISO 13849-1, Annex G) |
| Category | 3 |
| DC | Low |
| CCF | Measures required |
| MTTFd | High ¹ |
| Performance level (PL) | d |

Table 9-2 Connection of a suitable rotary transducer

| | |
|---|---|
| Basic safety principles | Must be used ¹ |
| Proven safety principles | Must be used ¹ |
| Additional requirements for systematic aspects | Must be met (see EN ISO 13849-1, Annex G) |
| Category | 2 ² |
| DC | Medium ² |
| CCF | Measures required ¹ |
| MTTFd | High ² |
| Performance level (PL) | d ² |

¹ In addition, observe the notes on Functional Safety in the operating instructions of the sensor manufacturer.

² In order to satisfy the above requirements, use the rotary transducer from the RVS58S series from Pepperl & Fuchs, for example.

10 Error detection

10.1 Initiator errors, data errors

The "Power" LED flashes at 2 Hz and error message output FO outputs a static signal.

Check the initiator or encoder connection and the parameterized data in the PSR-CONF-WIN software.

Check the following depending on the application:

Encoder

- Sin/Cos or TTL/HTL selection
- Sin/Cos or A/B tracks
- Negated Sin//Cos/ or A//B/ tracks

Initiators

- Operating distances/adjustment
- In IN1/IN2 mode, at least one initiator must be dampened.
- In IN1 mode, a jumper must be inserted from IN1 to IN2.

The error state can be acknowledged by a power on reset.



NOTE: No diagnostics for sensor errors

In order to diagnose sensor errors, the monitored speed must exceed six times the parameterized downtime frequency at least once per shift (which corresponds to an operating time of 8 hours).

10.2 Encoder errors

The "Power" LED is on and error message output FO outputs a static signal.

Check the RJ45 connection and supply voltage of the encoder.



The supply voltage of the encoder is not provided by the PSR-RSM4 and must therefore be supplied separately.

Depending on the assignment of the start circuit (S33, S34, S35), the PSR-RSM4 is started automatically or manually via the start button.

10.3 Error list

The PSR-RSM4 safety relay uses an LED blink code to indicate errors which can lead to the safe state of the safety relay.

The number of flashes denotes the number of the code. Only flash sequences from 1 ... 14 can occur. The blink code is repeated continuously. The start is indicated by a 1.5 second long pause.

Power LED flashing: error message 1st channel

Power LED and Output 2 LED flashing: error message 2nd channel

Table 10-1 Error list

| Blink code | Error type |
|------------|---|
| 1 | Internal device error |
| 2 | Button S34 closed on start |
| 3 | Initiator error two-channel |
| 4 | 3-channel error IN/RJ45 |
| 5 | Sin and Cos = 0 V |
| 6 | Frequency measurement not equal |
| 7 | Internal device error |
| 8 | Inputs I1, I2, I3, and MI are not equal |
| 9 | Internal device error |
| 10 | Internal device error |
| 11 | Internal device error |
| 12 | Internal device error |
| 13 | Internal device error |
| 14 | Initiator frequency > 4 kHz |

In order to use the safety relay again, it must be disconnected (power on reset).

11 Application examples

11.1 Application 1: basic machine

In application 1, a machine with a drive and guard is used as an example. The drive supplies the rotary movement information to the PSR-RSM4 via the flange-mounted rotary impulse encoder.

When the protective cover is closed, the operating mode switches to production (I1) and the drive can rotate at the maximum programmed speed. If the drive exceeds the maximum speed, contacts 13-14 and 23-24 open and the drive is stopped via the emergency stop circuit (stop category 0).

When the protective cover is open, the PSR-RSM4 monitors the downtime of the drive. If the drive starts up without permission due to an error in the control circuit, contacts 13-14 and 23-24 open and the drive is stopped immediately (stop category 0).

When the drive is turning, contacts 33-34 and 43-44 prevent the protective cover from being opened. Contacts 33-34 and 43-44 only close when the drive is in the stop state and the guard locking magnet opens the protective cover.

Following an overspeed, the PSR-RSM4 starts automatically with a jumper at S33-S35 or manually via a button at S33-S34.

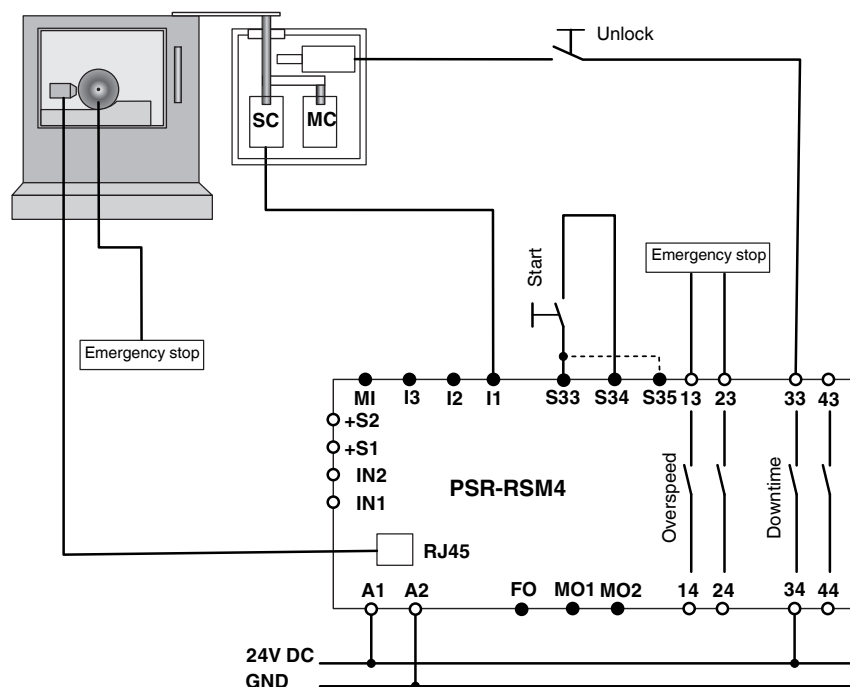

Figure 11-1 Application 1: basic machine

11.2 Application 2: basic machine with a monitored drive

In application 2, a machine with a drive, guard, enabling device, and operating mode selector switch is used as an example. The basic function is the same as application 1.

When the cover is closed, overspeed monitoring is not enabled (muting).

When the cover is open - depending on the selected input - monitoring can be enabled either for downtime only (enable switch not activated, no power to I2 and I3) or for the speeds parameterized under I2 and I3.

Following an overspeed, the PSR-RSM4 starts automatically with a jumper at S33-S35 or manually via a button at S33-S34.

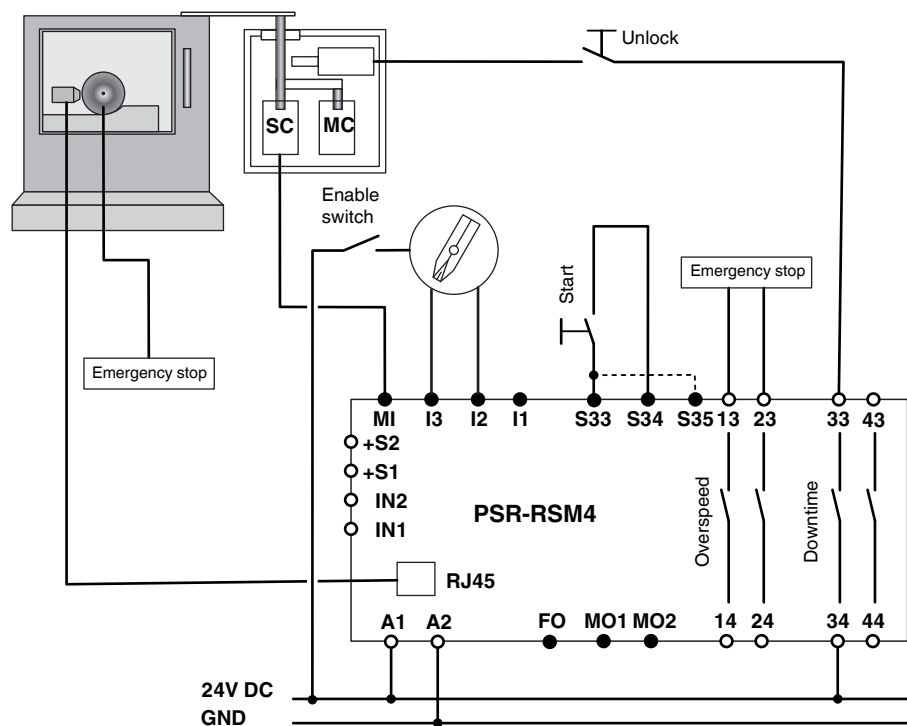

Figure 11-2 Application 2: basic machine with a monitored drive

11.3 Application 3: machine tool with several drives and differentiated operating modes

In application 3, a machine with several drives is monitored in a working area. The working area is protected by a protective cover with guard locking. For speed/emergency stop monitoring both drives are switched off. Drive 1 is monitored for maximum speed during production, drive 2 is not monitored (muting). Drive 1 can be rotated in set mode via the enable switch. Drive 2 can be rotated in set mode even without the enable switch. Both drives cannot be rotated at the same time.

Following an overspeed, the PSR-RSM4 module starts automatically with a jumper at S33-S35 or manually via a button at S33-S34.

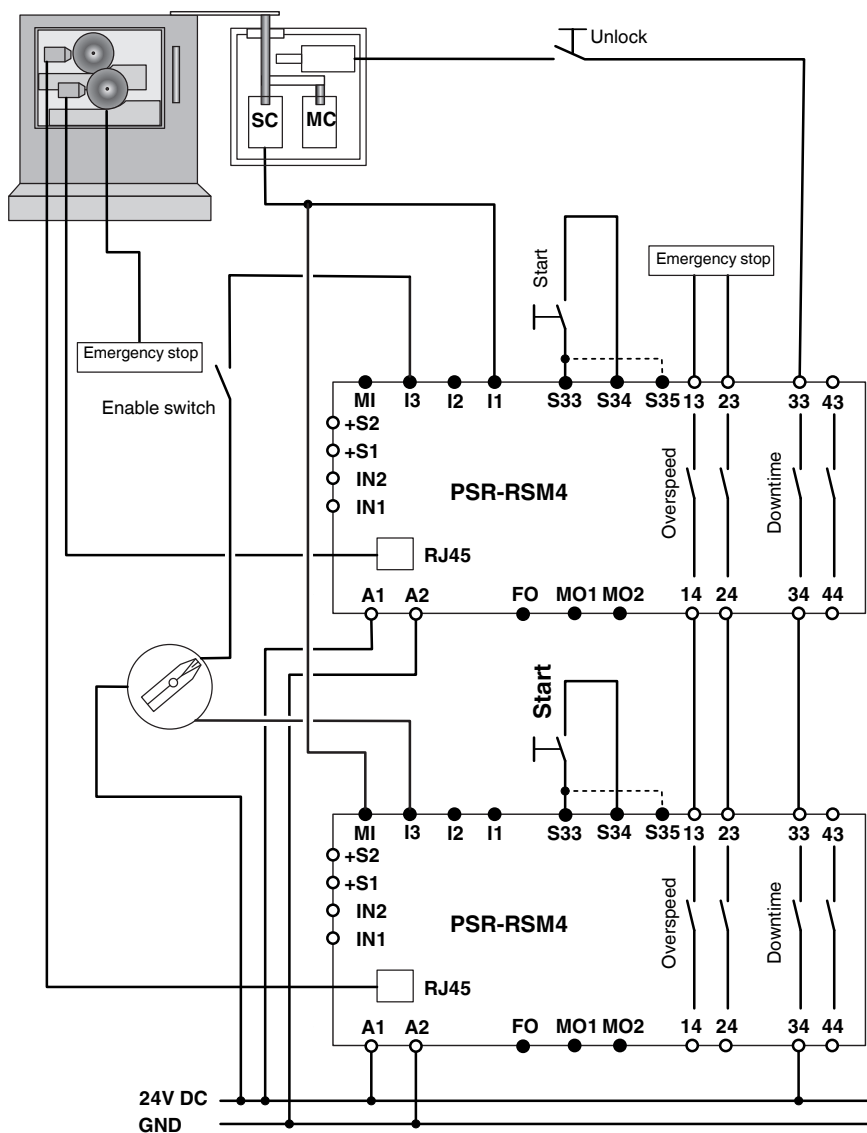

Figure 11-3 Application 3: machine tool with several drives and differentiated operating modes

11.4 Application 4: basic machine with monitored drive and additional drive shaft monitoring

In application 4, a machine with a drive, guard, enabling device, and operating mode selector switch is used as an example. The basic function is the same as application 1. In addition to drive monitoring, the drive shaft is monitored.

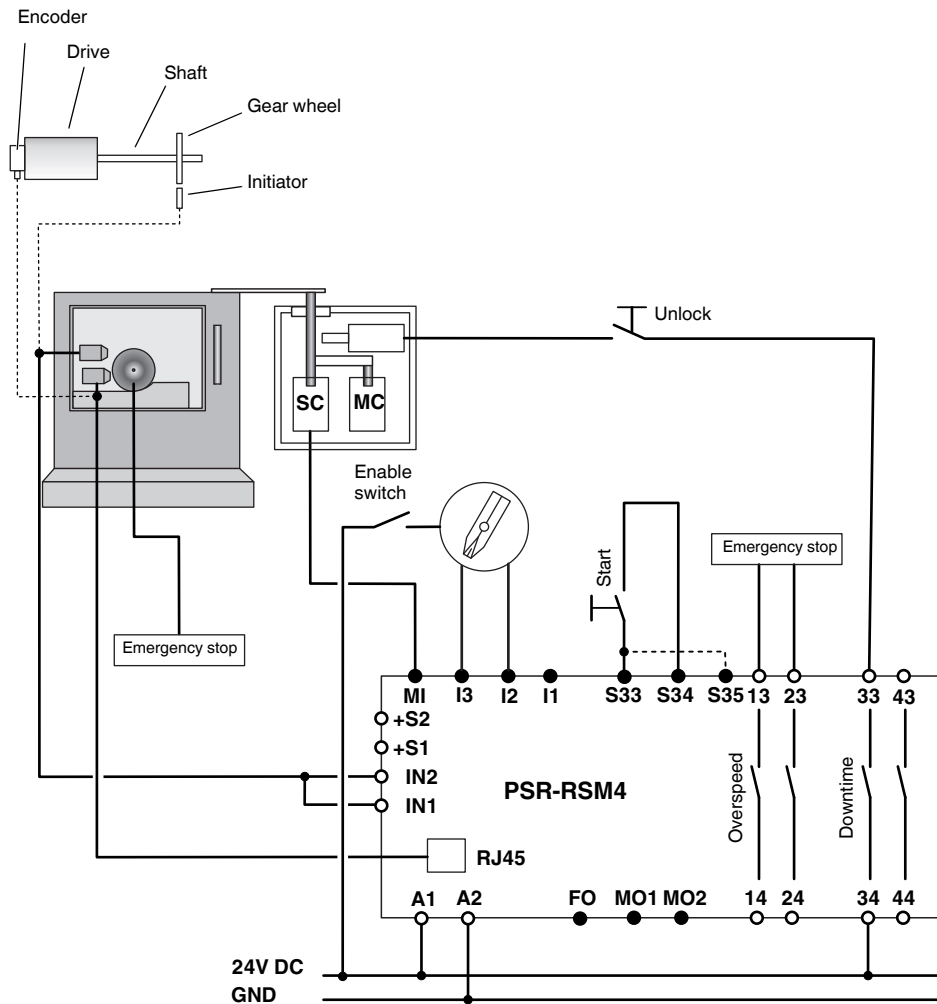

Figure 11-4 Application 4: basic machine with monitored drive and additional drive shaft monitoring

12 Technical data and ordering data

12.1 Technical data

Input data

| | |
|---|---------------------------------------|
| Nominal input voltage | 24 V DC |
| Permissible range (based on U_N) | 0.85 - 1.1 |
| Typical current consumption at U_N | 100 mA |
| Voltage at input, start, and feedback circuit | 24 V DC |
| Typical response time (K1, K2) at U_N | 15 ms |
| Typical release time (K1, K2) at U_N | 12 ms |
| Recovery time | 1 s |
| System response time | Depends on the frequency, see page 47 |

Output data

| | |
|--|---|
| Contact type | 4 enabling current paths |
| Contact material | Silver nickel 10 (AgNi10) 5 μ m gold-flashed |
| Maximum / minimum switching voltage | 250 V AC/DC / 10 V AC/DC |
| Limiting continuous current | 5 A ¹ |
| Maximum / minimum switch-on current | 6 A / 1 mA ² |
| Maximum interrupting rating | Ohmic load $t = 0$ ms, inductive load $t = 40$ ms On request |
| | 24 V DC 48 V DC 110 V DC 220 V DC 250 V AC |
| Minimum switching capacity | 0.1 W |
| Mechanical service life | $\geq 50 \times 10^6$ switching cycles |
| Switching capacity according to DIN EN 60947-5-1/VDE 0660 Part 200 | Switching cycles: 360/h 24 V (DC13) 5 A; 230 V (AC15) 5 A |
| Short-circuit protection of the output circuits | 6 A gL (automatic device C8) |
| Current carrying capacity of signal outputs FO, MO1, and MO2 | 100 mA, short-circuit-proof |

¹ Total current on request.

² Up to a maximum switching current of 0.3 A

PSR-CONF-WIN

| General data | | |
|--|---|--|
| Ambient temperature range | -20°C ... +55°C | |
| Nominal operating mode | 100% operating time | |
| Air and creepage distances between the circuits | DIN EN 50178/VDE 0160: 1998-04, basic insulation ¹ | |
| Rated voltage | 250 V | |
| Rated surge voltage | 4 kV ¹ | |
| Pollution degree | 2 | |
| Surge voltage category | III | |
| Mounting position | Any | |
| ¹ Safe isolation, reinforced insulation, and 6 kV between the input circuit and the output contact current paths. | | |
| Dimensions | Screw connection | Spring connection |
| W / H / D | 45 mm / 99 mm / 114.5 mm | 45 mm / 112 mm / 114.5 mm |
| Connection data | Screw connection | Spring connection |
| Conductor cross section | 0.2 mm ² ... 2.5 mm ² (24 - 12 AWG) | 0.2 mm ² ... 1.5 mm ² (24 - 16 AWG) |
| Stripping length | 7 mm | 12 mm |
| Safety characteristics according to IEC 61508 | | |
| SIL | 3 | |
| PFH (probability of a dangerous failure per hour for the entire module) | 7.9 x 10 ⁻⁹ | |
| Safety characteristics according to EN 62061 | | |
| SIL claim limit | 3 | |
| PFH (probability of a dangerous failure per hour for the entire module) | 7.9 x 10 ⁻⁹ | |
| Safety characteristics according to EN ISO 13849-1 | | |
| Category | 4 | |
| Performance level | e | |

12.2 Ordering data

Products

| Description | Type | Order No. | Pcs. / Pkt. |
|--|-----------------------|-----------|-------------|
| Safe speed monitoring with screw connection | PSR-SCP-24DC/RSM4/4X1 | 2981538 | 1 |
| Safe speed monitoring with spring connection | PSR-SPP-24DC/RSM4/4X1 | 2981541 | 1 |

Accessories

| Description | Type | Order No. | Pcs. / Pkt. |
|---|---|-----------|-------------|
| PSR configuration software with connecting cable, for configuring the PSR-RSM4 safety relay, language: German, English, French, Italian, and Spanish | PSR-CONF-WIN1.0 | 2981554 | 1 |
| Cable adapter for PSR-RSM4 Cable length: 2.5 m | See "Adaptation to existing drive systems" on page 25 | | |
| Adapter for PSR-RSM4 , hardware interface for HTL encoder - signal conditioning | PSR-RSM-HTL-ADAPTER | 2981897 | 1 |

PSR-CONF-WIN

A Appendix for document lists

A 1 List of figures

Section 2

| | | |
|-------------|--|----|
| Figure 2-1: | Product image for the PSR-RSM4 | 15 |
| Figure 2-2: | Connection versions for the PSR-RSM4 | 15 |
| Figure 2-3: | Operating elements of the PSR-RSM4 | 16 |
| Figure 2-4: | Block diagram for the PSR-RSM4 | 17 |
| Figure 2-5: | Function diagram | 18 |

Section 4

| | | |
|--------------|---|----|
| Figure 4-1: | Interface cable with RJ45 and D9-SUB connector plug | 21 |
| Figure 4-2: | Connection with RJ45 connector | 22 |
| Figure 4-3: | Connection example | 22 |
| Figure 4-4: | Mounting initiators | 24 |
| Figure 4-5: | Y adapter | 25 |
| Figure 4-6: | Connection for the supply voltage | 26 |
| Figure 4-7: | Priority of terminal blocks | 27 |
| Figure 4-8: | Connecting contacts 13-14 and 23-24 in series | 28 |
| Figure 4-9: | Connecting contacts 33-34 and 43-44 in series | 28 |
| Figure 4-10: | Connecting the signal and error message outputs | 29 |

Section 5

| | | |
|-------------|---|----|
| Figure 5-1: | Installation start screen | 31 |
| Figure 5-2: | Software license terms | 32 |
| Figure 5-3: | Selecting the installation directory | 32 |
| Figure 5-4: | Selecting the type of installation | 33 |
| Figure 5-5: | Selecting the program name for the Start menu | 33 |
| Figure 5-6: | Completing the installation | 34 |
| Figure 5-7: | Desktop shortcut | 34 |

Section 6

| | | |
|-------------|---|----|
| Figure 6-1: | Start screen of the parameterization software | 35 |
| Figure 6-2: | Start screen of the parameterization software | 38 |

PSR-CONF-WIN

| | | |
|-------------|------------------------------|----|
| Figure 6-3: | Ratio example | 39 |
| Figure 6-4: | Shaft break monitoring | 43 |

Section 11

| | | |
|--------------|--|----|
| Figure 11-1: | Application 1: basic machine | 53 |
| Figure 11-2: | Application 2: basic machine with a monitored drive | 54 |
| Figure 11-3: | Application 3: machine tool with several drives and differentiated operating modes | 55 |
| Figure 11-4: | Application 4: basic machine with monitored drive and additional drive shaft monitoring | 56 |

A 2 List of tables

Section 4

| | | |
|------------|---|----|
| Table 4-1: | Adaptation to existing drive systems..... | 25 |
|------------|---|----|

Section 6

| | | |
|------------|-----------------------------------|----|
| Table 6-1: | Toolbar for parameterization..... | 35 |
|------------|-----------------------------------|----|

Section 9

| | | |
|------------|--|----|
| Table 9-1: | Connection of two proximity switches..... | 50 |
| Table 9-2: | Connection of a suitable rotary transducer | 50 |

Section 10

| | | |
|-------------|------------------|----|
| Table 10-1: | Error list | 52 |
|-------------|------------------|----|

PSR-CONF-WIN

B Revision history

| Revision | Date | Contents |
|----------|------------|--|
| 03 | 2014-10-02 | Editorial revision Revision of section structure "Requirements for subsystems when using different sensors" on page 50 added. Information on safety characteristics added to "Technical data and ordering data" on page 57. |

PSR-CONF-WIN



SCATTERGOOD & JOHNSON LTD

ELECTRICAL ENGINEERING & FLUID CONTROL DISTRIBUTORS

Est.1899

At Scattergood & Johnson Ltd, we pride ourselves on being a technical distributor to specialist industries.

Working with a range of quality product suppliers across a number of specialist markets, we are not your average 'box shifter' - we are your technical and supply chain partner.

We fully support every product we sell - for free! Our internal team and external sales engineers can answer any product or application question, no matter the complexity.

Backing up this technical ability is a range of 50,000+ products available from stock for nationwide next day delivery (same day if required!), or you can collect what you need from any of our trade counters around the UK.

Select your specialist interest below to learn more about how we can help.

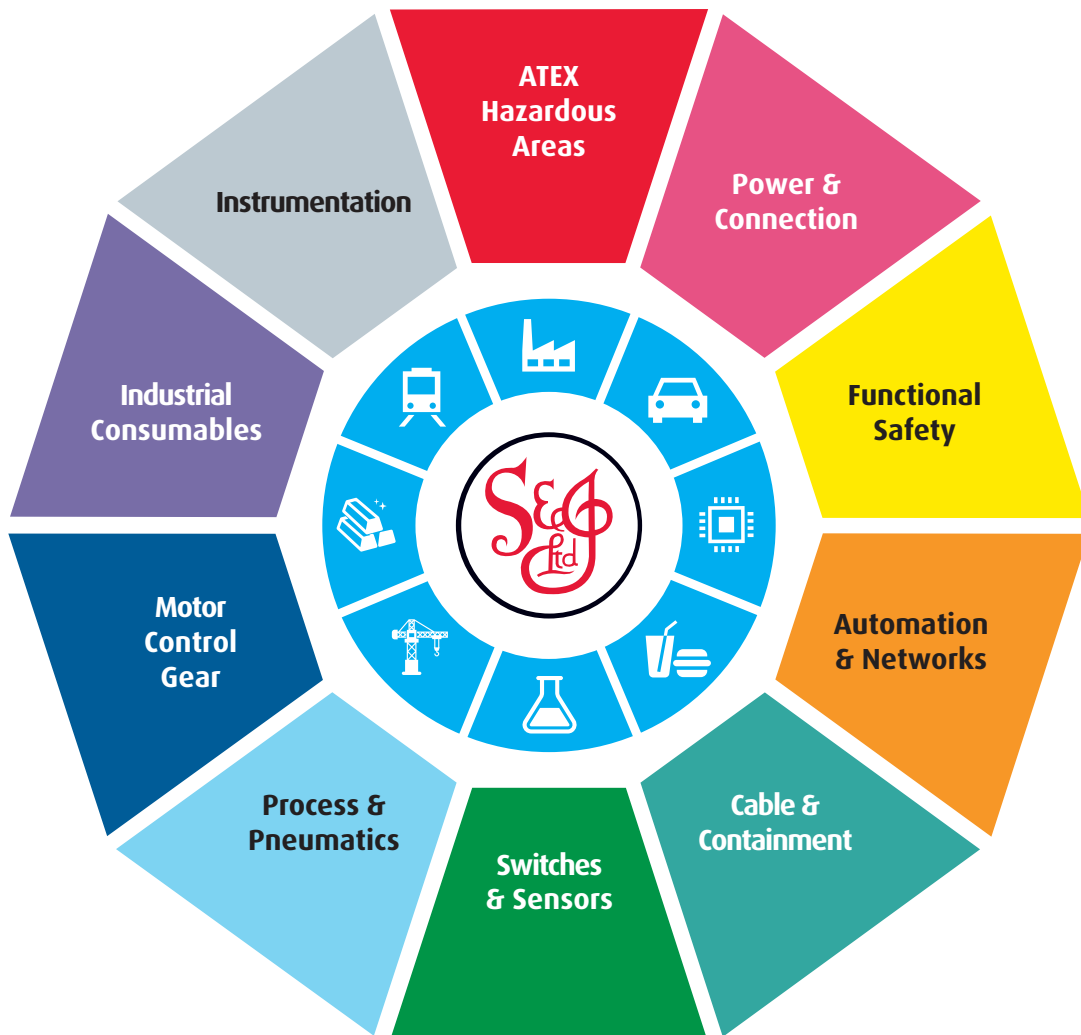

Online, In Branch and On the Road - Scattergood & Johnson Ltd, there when you need us.

www.scatts.co.uk