

PSR-TRISAFE system diagnostics

Diagnostics of PSR-TRISAFE safety modules via interface system gateways of type EM-xxx-GATEWAY-IFS



Application note
108139_en_00

© PHOENIX CONTACT 2017-10-13

1 Description

For diagnostics purposes, you can connect your PSR-TRISAFE system with interface system gateways of type EM-xxx-GATEWAY-IFS to a superordinate controller. For this, connect at most one gateway to the safety module PSR-TRISAFE-S or PSR-TRISAFE-M to transmit diagnostic data. Diagnostics readouts are bus-specific.

This application note informs you on:

- Basic hardware setup for diagnostics with gateways
- Status and diagnostics words in which the diagnostic information of the PSR-TRISAFE system is mapped
- Error codes and corrective measures in the event of an error

Requirement

You must be familiar with the integration of interface system gateways into your target system.



You will find corresponding application notes in the gateway's download area on how to start up IFS gateways in usual bus systems.



Make sure you always use the latest documentation. It can be downloaded at phoenixcontact.net/products.



This document is valid for products listed in the Section „Ordering data“ on page 3.

Table of contents

1	Description.....	1
2	Ordering data.....	3
3	Documentation	5
4	Safety hotline	5
5	Basic hardware setup	6
6	Fieldbus configuration.....	7
7	Status and diagnostic words.....	8
7.1	PSR-TRISAFE-S.....	8
7.1.1	Status words	8
7.1.2	Diagnostic words	9
7.2	PSR-TRISAFE-M	10
7.2.1	Status words	10
7.2.2	Diagnostic words	12
7.3	PSR-TS-SDI8-SDIO4 and PSR-TS-SDOR4.....	13
8	Error codes	14
8.1	PSR-TRISAFE-S and PSR-TRISAFE-M.....	14
8.2	PSR-TS-SDI8-SDIO4 and PSR-TS-SDOR4.....	17
9	Revision history	18

2 Ordering data

PSR-TRISAFE safety modules

Description	Type	Order No.	Pcs./Pkt.
Configurable safety module, non-extendable , DIN rail connector is included			
Module with screw connections	PSR-SCP-24DC/TS/S	2986229	1
Module with spring-cage connections	PSR-SPP-24DC/TS/S	2986232	1
Configurable safety module, extendable , DIN rail connector is included			
Module with screw connections	PSR-SCP-24DC/TS/M	2986012	1
Module with spring-cage connections	PSR-SPP-24DC/TS/M	2986025	1
Configurable safe extension module with parameterizable inputs/outputs , DIN rail connector is included			
Module with screw connections	PSR-SCP-24DC/TS/SDI8/SDIO4	2986038	1
Module with spring-cage connections	PSR-SPP-24DC/TS/SDI8/SDIO4	2986041	1
Configurable safe extension module with relay outputs , DIN rail connector is included			
Module with screw connections	PSR-SCP-24DC/TS/SDOR4/4x1	2986096	1
Module with spring-cage connections	PSR-SPP-24DC/TS/SDOR4/4x1	2986106	1

Gateways

Description	Bus system	Type	Order No.	Pcs./Pkt.
Gateway for the connection of up to 32 INTERFACE system devices to a superordinate controller, DIN rail connector is included	CANopen®	EM-CAN-GATEWAY-IFS	2901504	1
Gateway for the connection of up to 32 INTERFACE system devices to a superordinate controller, DIN rail connector is included	Modbus/TCP	EM-MODBUS-GATEWAY-IFS	2901528	1
Gateway for the connection of up to 32 INTERFACE system devices to a superordinate controller, DIN rail connector is included	DeviceNet™	EM-DNET-GATEWAY-IFS	2901529	1
Gateway for the connection of up to 32 INTERFACE system devices to a superordinate controller, DIN rail connector is included	EtherNet/IP™	EM-ETH-GATEWAY-IFS	2901988	1
Gateway for the connection of up to 32 INTERFACE system devices to a superordinate controller, DIN rail connector is included	PROFINET	EM-PNET-GATEWAY-IFS	2904472	1

Gateways

Description	Bus system	Type	Order No.	Pcs./Pkt.
Gateway for the connection of up to 32 INTERFACE system devices to a superordinate controller, DIN rail connector is included	PROFIBUS DP	EM-PB-GATEWAY-IFS	2297620	1
Gateway for the connection of up to 32 INTERFACE system devices to a superordinate controller, DIN rail connector is included	Modbus/RS-232	EM-RS232-GATEWAY-IFS	2901526	1
Gateway for the connection of up to 32 INTERFACE system devices to a superordinate controller, DIN rail connector is included	Modbus/RS-485	EM-RS485-GATEWAY-IFS	2901527	1

Software

Description	Type	Order No.
Configuration software for SafetyBridge Technology and PSR-TRISAFE modules, connecting cable for PSR-TRISAFE	SAFECONF	2986119
IFS-CONF-SUITE-INTERFACE Setup (FTD Container: IFS-CONF + INTERFACE SYSTEM DTMs + INTERFACE ANALOG DTMs + USB driver)	IFS-CONF-SUITE-INTERFACE_1vxx.zip	See download area of the gateway used



You need the configuration software IFS-CONF for all usual bus systems apart from PROFIBUS. See Section 6 "Fieldbus configuration".

3 Documentation



Observe the product documentation valid for the devices you are using.
Make sure you always use the latest documentation.
It can be downloaded at phoenixcontact.net/products.

System-relevant documents

Refer also to the following additional system-relevant documents.

Description	Designation
User manual PSR-TRISAFE system: configurable safety modules and safe extension modules	UM EN PSR-TRISAFE system
User manual IFS system <ul style="list-style-type: none"> • Motor management • Gateways • Hybrid motor starter 	UM EN IFS system
Application note Interface system gateways and digital extension modules	AH EN EM-xxx-GATEWAY-IFS
Application note EM-PNET-GATEWAY-IFS and ELR H5-IES-SC/500AC-3-IFS	AH EN EM-PNET-GATEWAY-IFS
Setup of EM-PNET-GATEWAY-IFS via IFS-TCP-PROG-ADAPTER with the IFS-CONF software	AH EN EM-PNET-GATEWAY-IFS / IFS-CONF

SAFECONF



For additional information and detailed step-by-step instructions for the SAFECONF configuration software, please refer to the online help of the software.

You will find the diagnostic messages for all safe blocks as an XLS file in the download area of the PSR-TRISAFE modules. This file is used, for example, for integration into your visualization.

See document SC_FB_DIAG_VXX_xx.xlsm.

See also "DiagFBQ_wxxx" in Section 7.2.1 "Status words" .

4 Safety hotline

Should you have any technical questions, please contact our 24-hour hotline.

Phone: +49 5281 9462777

E-mail: safety-service@phoenixcontact.com

5 Basic hardware setup

Only connect at most one gateway of type EM-xxx-GATEWAY-IFS to the safety module PSR-TRISAFE-S or PSR-TRISAFE-M in combination with the green DIN rail connector TBUS.

If you use the extendable safety module PSR-TRISAFE-M, you can connect further safe extension modules PSR-TS-SDI8-SDIO4 and/or PSR-TS-SDOR4. For this, use the yellow DIN rail connector PSR-TBUS.



Note the assembly instructions for non-safe and safe extension devices in the PSR-TRISAFE system. See user manual for UM EN PSR-TRISAFE system.

Assembly instructions

- Always mount the gateway to the **left** of safety module PSR-TRISAFE-S or PSR-TRISAFE-M.
- Only use the **green** DIN rail connector TBUS to connect the gateway.
- Always mount the safe extension modules PSR-TS-SDI8-SDIO4 and/or PSR-TS-SDOR4 to the **right** of safety module PSR-TRISAFE-M.
- Only use the **yellow** DIN rail connector PSR-TBUS to connect the safe extension modules.



NOTE: Module damage

Using an incorrect DIN rail connector or a dummy plug can cause the module to become faulty.

- Always use the correct DIN rail connector (**green** for gateways, **yellow** for safety modules and safe extension modules).
- **Never** use the PSR-TBUS-TP dummy plug.

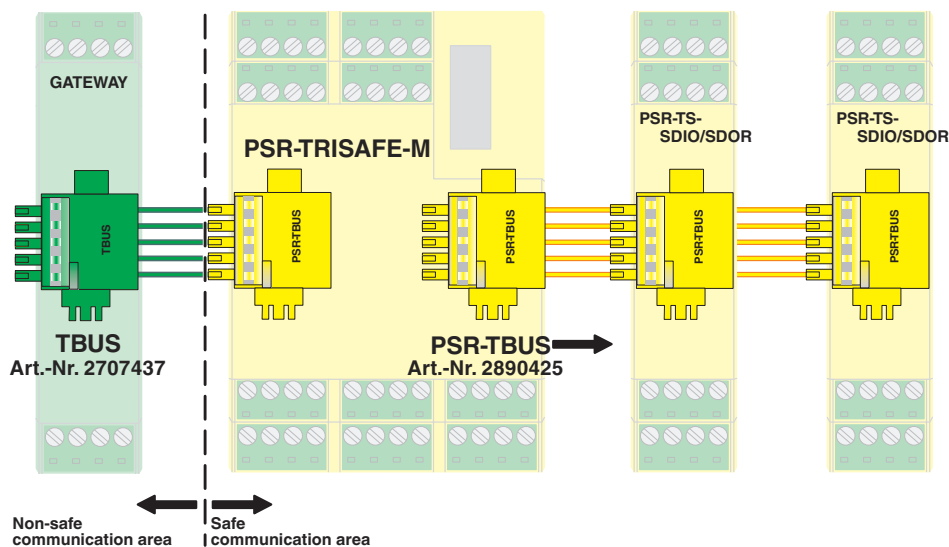

Figure 1 Connecting a gateway and safe extension modules in the PSR-TRISAFE system

6 Fieldbus configuration

The following IFS gateways are suitable for use with the PSR-TRISAFE system. You have the following options for field bus configuration depending on the used gateway or target system:

- Use of IFS-CONF software
- Use of the gateway's web server
- Integration of the GSD file of the gateway



You will find corresponding application notes in the gateway's download area on how to start up IFS gateways in usual bus systems:

AH EN EM-xxx-GATEWAY-IFS

AH EN EM-PNET-GATEWAY-IFS

AH EN EM-PNET-GATEWAY-IFS / IFS-CONF

Order No.	Type	Bus system	Configuration possible via:		
			IFS-CONF	Web server	GSD file
2901504	EM-CAN-GATEWAY-IFS	CANopen®	✓		
2901528	EM-MODBUS-GATEWAY-IFS	Modbus/TCP	✓	✓	
2901529	EM-DNET-GATEWAY-IFS	DeviceNet™	✓		
2901988	EM-ETH-GATEWAY-IFS	EtherNet/IP™	✓	✓	
2904472	EM-PNET-GATEWAY-IFS	PROFINET	✓	✓	
2297620	EM-PB-GATEWAY-IFS	PROFIBUS DP	Optional		✓
2901526	EM-RS232-GATEWAY-IFS	Modbus/RS-232	✓		
2901527	EM-RS485-GATEWAY-IFS	Modbus/RS-485	✓		

7 Status and diagnostic words

At most 16 process data words are read from the PSR-TRISAFE system with a gateway of type EM-xxx-GATEWAY-IFS.

The diagnostics covers the safety module PSR-TRISAFE-S or PSR-TRISAFE-M, as well as up to 10 safe extension modules PSR-TS-SDI8-SDIO4 and/or PSR-TS-SDOR4.

The status of the inputs and outputs of the safe extension modules cannot be read back via process data. These must be realized, if necessary, via the applicative diagnostics (e.g. via the external signals in SAFECNF).



You can also find the assignment of the status and diagnostic words in the SAFECNF dialog window "Project information/Diagnostic addresses".

7.1 PSR-TRISAFE-S

7.1.1 Status words

SafeIn_w1

Status word of the safe inputs I0 to I15

Bit	15	14	13	12	11	10	09	08	07	06	05	04	03	02	01	00
Input	I15	I14	I13	I12	I11	I10	I9	I8	I7	I6	I5	I4	I3	I2	I1	I0

SafeIn_w2

Status word of the safe inputs I16 to I19

Bit	15	14	13	12	11	10	09	08	07	06	05	04	03	02	01	00
Input	-	-	-	-	-	-	-	-	-	-	-	-	I19	I18	I17	I16

SafeOut_w1

Status word of the safe outputs

Bit	15	14	13	12	11	10	09	08	07	06	05	04	03	02	01	00
Input	-	-	-	-	-	-	-	-	-	-	-	-	O3	O2	O1	O0

DiagIn_w3

Status word of the diagnostic LEDs PWR, ERR and DATA

Bit	15	14	13	12	11	10	09	08	07	06	05	04	03	02	01	00
Input	-	-	-	-	-	-	-	-	-	-	-	-	-	ERR	DATA	PWR

NoneSafeOUT_w1

Status word of the status signals M0 to M3, as well as the external signals EQ00 – EQ11 from SAFECNF

Bit	15	14	13	12	11	10	09	08	07	06	05	04	03	02	01	00
Input	EQ11	EQ10	EQ09	EQ08	EQ07	EQ06	EQ05	EQ04	EQ03	EQ02	EQ01	EQ00	M3	M2	M1	M0

NoneSafeOUT_w2

Status word of the external signals EQ12 – EQ27 from SAFECONF

Bit	15	14	13	12	11	10	09	08	07	06	05	04	03	02	01	00
Input	EQ27	EQ26	EQ25	EQ24	EQ23	EQ22	EQ21	EQ20	EQ19	EQ18	EQ17	EQ16	EQ15	EQ14	EQ13	EQ12

Safe_Error

Device internal error messages

Bit	15	14	13	12	11	10	09	08	07	06	05	04	03	02	01	00
	Error codes channel 1 Low byte μ C1: 0x80xx								Error codes channel 2 Low byte μ C2: 0x90xx							
Hex	X				X				X				X			



For a list of possible error codes, please refer to Section 8 “Error codes”.

7.1.2 Diagnostic words

The diagnostic words report diagnostic events at the inputs and outputs of the safety module PSR-TRISAFE-S.

DE-ERR1

Diagnostic events at the inputs I0 to I13 (2 bit offset)

Bit	15	14	13	12	11	10	09	08	07	06	05	04	03	02	01	00
Input	I13	I12	I11	I10	I9	I8	I7	I6	I5	I4	I3	I2	I1	I0	-	-

DE-ERR2

Diagnostic events at the inputs I14 to I19

Bit	15	14	13	12	11	10	09	08	07	06	05	04	03	02	01	00
Input	I13	I12	I11	I10	I9	I8	I7	I6	I5	I4	I19	I18	I17	I16	I15	I14

Possible causes:

- Incorrect wiring of the input
- No correct switching signals from the perspective of the safe block connected to this input

If an input recognizes a cross-circuit, this event is reported by the corresponding bit. If several inputs are faulty, several bits are set accordingly.

If there is a cross-circuit at an input, the entire corresponding clock generator goes out of tact. For this reason, all the inputs that are supplied via T0 and T1 report a cross-circuit.

DA-ERR

Diagnostic events at the outputs O0 to O03

Bit	15	14	13	12	11	10	09	08	07	06	05	04	03	02	01	00
Input	-	-	-	-	-	-	-	-	-	-	-	-	O3	O2	O1	O0

Possible causes:

- Feedback
- Cross-circuit
- Overload

7.2 PSR-TRISAFE-M**7.2.1 Status words****Safeln_w1**

Status word of the safe inputs I0 to I15

Bit	15	14	13	12	11	10	09	08	07	06	05	04	03	02	01	00
Input	I15	I14	I13	I12	I11	I10	I9	I8	I7	I6	I5	I4	I3	I2	I1	I0

Safeln_w2

Status word of the safe inputs I16 to I19

Bit	15	14	13	12	11	10	09	08	07	06	05	04	03	02	01	00
Input	-	-	-	-	-	-	-	-	-	-	-	-	I19	I18	I17	I16

SafeOut_w1

Status word of the safe outputs

Bit	15	14	13	12	11	10	09	08	07	06	05	04	03	02	01	00
Input	-	-	-	-	-	-	-	-	-	-	-	-	O3	O2	O1	O0

DiagIn_w3

Status word of the diagnostic LEDs PWR, ERR and DATA

Bit	15	14	13	12	11	10	09	08	07	06	05	04	03	02	01	00
Input	-	-	-	-	-	-	-	-	-	-	-	-	-	ERR	DATA	PWR

NoneSafeOUT_w1

Status word of the status signals M0 to M3, as well as the external signals EQ00 – EQ11 from SAFECNF

Bit	15	14	13	12	11	10	09	08	07	06	05	04	03	02	01	00
Input	EQ11	EQ10	EQ09	EQ08	EQ07	EQ06	EQ05	EQ04	EQ03	EQ02	EQ01	EQ00	M3	M2	M1	M0

NoneSafeOUT_w2

Status word of the external signals EQ12 – EQ27 from SAFECONF

Bit	15	14	13	12	11	10	09	08	07	06	05	04	03	02	01	00
Input	EQ27	EQ26	EQ25	EQ24	EQ23	EQ22	EQ21	EQ20	EQ19	EQ18	EQ17	EQ16	EQ15	EQ14	EQ13	EQ12

NoneSafeOUT_w3

Status word of the external signals EQ28 – EQ43 from SAFECONF

Bit	15	14	13	12	11	10	09	08	07	06	05	04	03	02	01	00
Input	EQ43	EQ42	EQ41	EQ40	EQ39	EQ38	EQ37	EQ36	EQ35	EQ34	EQ33	EQ32	EQ31	EQ30	EQ29	EQ28

NoneSafeOUT_w4

Status word of the external signals EQ44 – EQ59 from SAFECONF

Bit	15	14	13	12	11	10	09	08	07	06	05	04	03	02	01	00
Input	EQ59	EQ58	EQ57	EQ56	EQ55	EQ54	EQ53	EQ52	EQ51	EQ50	EQ49	EQ48	EQ47	EQ46	EQ45	EQ44

NoneSafeOUT_w5

Status word of the external signals EQ60 – EQ64 from SAFECONF

Bit	15	14	13	12	11	10	09	08	07	06	05	04	03	02	01	00
Input	-	-	-	-	-	-	-	-	-	-	-	-	EQ63	EQ62	EQ61	EQ60

SLx_DiagIN_w2**(x = 1 - 10)**

Status word 2 of safe extension modules 1 - 10

Bit	15	14	13	12	11	10	09	08	07	06	05	04	03	02	01	00
Hex	X			X				X			X					

SLx_DiagIN_w3**(x = 1 - 10)**

Status word 3 (LED status) of safe extension modules 1 - 10

Bit	15	14	13	12	11	10	09	08	07	06	05	04	03	02	01	00
Input	-	-	-	-	-	-	-	-	-	-	-	-	-	ERR	-	PWR

DiagFBQ_wxxx**(xxx = 001 - 128)**

Status word of the block diagnostics of the safe block instances 1 - 128 from SAFECONF.

Bit	15	14	13	12	11	10	09	08	07	06	05	04	03	02	01	00
Hex	X				X				X				X			



Every safe function block of the configuration software SAFECONF is automatically assigned an instance number. You can find them in the SAFECONF dialog window "Project information/Diagnostic addresses".

You will find the diagnostic messages for all safe blocks as an XLS file in the download area of the PSR-TRISAFE modules. This file is used, for example, for integration into your visualization.

See document SC_FB_DIAG_VXX_xx.xlsm.

Error_Code

Device internal error messages

Bit	15	14	13	12	11	10	09	08	07	06	05	04	03	02	01	00
	Error codes channel 1 Low byte μ C1: 0x80xx								Error codes channel 2 Low byte μ C2: 0x90xx							
Hex	X				X				X				X			



For a list of possible error codes, please refer to Section 8 "Error codes".

7.2.2 Diagnostic words

The diagnostic words report diagnostic events at the inputs and outputs of the safety module PSR-TRISAFE-M.

DE-ERR1

Diagnostic events at the inputs I0 to I13 (2 bit offset)

Bit	15	14	13	12	11	10	09	08	07	06	05	04	03	02	01	00
Input	I13	I12	I11	I10	I9	I8	I7	I6	I5	I4	I3	I2	I1	I0	-	-

DE-ERR2

Diagnostic events at the inputs I14 to I19

Bit	15	14	13	12	11	10	09	08	07	06	05	04	03	02	01	00
Input	I13	I12	I11	I10	I9	I8	I7	I6	I5	I4	I19	I18	I17	I16	I15	I14

Possible causes:

- Incorrect wiring of the input
- No correct switching signals from the perspective of the safe block connected to this input

If an input recognizes a cross-circuit, this event is reported by the corresponding bit. If several inputs are faulty, several bits are set accordingly.

If there is a cross-circuit at an input, the entire corresponding clock generator goes out of tact. For this reason, all the inputs that are supplied via T0 and T1 report a cross-circuit.

DA-ERR

Diagnostic events at the outputs O0 to O03

Bit	15	14	13	12	11	10	09	08	07	06	05	04	03	02	01	00
Input	-	-	-	-	-	-	-	-	-	-	-	-	O3	O2	O1	O0

Possible causes:

- Feedback
- Cross-circuit
- Overload

7.3 PSR-TS-SDI8-SDIO4 and PSR-TS-SDOR4**SLx_DiagIN_w2****(x = 1 - 10)**

Status word for diagnostic messages of safe extension modules



For a list of relevant error codes for the safe extension modules, please refer to Section 8 "Error codes" .

8 Error codes



The following error codes are displayed in the configuration software SAFECNF.
If error codes are indicated by the system that do not appear in the table, please contact Phoenix Contact .

8.1 PSR-TRISAFE-S and PSR-TRISAFE-M

Error Code (Hex)	Description	Possible causes / Comment	Remedy
8001	Timeout of interprocessor communication	Error code occurs together with code 9068.	Perform a firmware update to version > 1529.
8004	Channel 2 not ready for interprocessor communication	Error can occur with firmware version 1527.	Perform a firmware update to version > 1529.
8020	Invalid file ID	Parameterization error – E.g. PSR-TRISAFE-S selected but project loaded to PSR-TRISAFE-M	Check and correct the parameterization.
8065	Test of the voltage monitoring failed in channel 1 – Error code occurs together with code 9066, where applicable.	– Undervoltage of supply voltage – Ground switching outputs mixed up with GND connection, contactors at A2/24 V	Check and correct the supply voltage. Check the GND connection and the contactors' connection.
8066	Test of the voltage monitoring failed in channel 2 – Error code occurs together with code 9065, where applicable.	– 24 V feedback at a safe output	Check if there is feedback at the safe outputs.
807c	CRC error of data of the TBUS of channel 2 Extension module has rejected parameter	Parameterization error in extension module – Outputs are parameterized as inputs – Signal outputs are not changed over to clock output – Signal outputs and clock outputs are mixed-up	Check and correct the parameterization.
8096	Invalid number of safe extension modules	– Extension module connected to the left of the safety module – More modules in the project than actually connected, or vice-versa – One or more extension modules is faulty	Reset the safety module to the factory default. Position the extension module to the right of the safety module. Check and correct the number of modules. Replace the faulty modules.
8097	Invalid ID of the extension devices	A different extension module than the actual hardware structure is integrated in the project.	Check and correct the project or the hardware structure.
80a7	Incorrect DEVICE-ID in the parameter file	PSR-TRISAFE-S configured instead of PSR-TRISAFE-M	Check and correct the project or the hardware structure.
80a9	No parameter file present	No project was downloaded onto the IFS-CONFSTICK.	Download the project onto the IFS-CONFSTICK.

PSR-TRISAFE system diagnostics

Error Code (Hex)	Description	Possible causes / Comment	Remedy
80aa	FRAM not connected	Faulty IFS-CONFSTICK / Faulty project	Reformat the IFS-CONFSTICK (SAFECONF function "Reset to factory default"). Use a new IFS-CONFSTICK.
80bf	Error state was set		Reformat the IFS-CONFSTICK (SAFECONF function "Reset to factory default").
80c5	Test of the voltage monitoring failed	<ul style="list-style-type: none"> - Surge voltage - Undervoltage 	Check and correct the supply voltage.
80c6	External FRAM stick not connected	IFS-CONFSTICK was removed and inserted during operating.	Observe the information in the user manual.
80e9	Test of the IO register failed in channel 1	Firmware error after 496 days	Carry out a firmware update.
9004	Channel 2 not ready for interprocessor communication	Error can occur with firmware version 1527.	Perform a firmware update to version > 1529.
9020	Invalid file ID	Parameterization error <ul style="list-style-type: none"> - E.g. PSR-TRISAFE-S selected but project loaded to PSR-TRISAFE-M 	Check and correct the parameterization.
9065	Test of the voltage monitoring failed in channel 1 <ul style="list-style-type: none"> - Error code occurs together with code 8066, where applicable. 	<ul style="list-style-type: none"> - Undervoltage of supply voltage - Ground switching outputs mixed up with GND connection, contactors at A2/24 V 	Check and correct the supply voltage. Check the GND connection and the contactors' connection.
9066	Test of the voltage monitoring failed in channel 2 <ul style="list-style-type: none"> - Error code occurs together with code 8065, where applicable. 	<ul style="list-style-type: none"> - 24 V feedback at a safe output 	Check if there is feedback at the safe outputs.
907c	CRC error of data of the TBUS of channel 2 Extension module has rejected parameter	Parameterization error in extension module <ul style="list-style-type: none"> - Outputs are parameterized as inputs - Signal outputs are not changed over to clock output - Signal outputs and clock outputs are mixed-up 	Check and correct the parameterization.
9096	Invalid number of safe extension modules	<ul style="list-style-type: none"> - Extension module connected to the left of the safety module - More modules in the project than actually connected, or vice-versa - One or more extension modules is faulty 	Reset the safety module to the factory default. Position the extension module to the right of the safety module. Check and correct the number of modules. Replace the faulty modules.

PSR-TRISAFE system diagnostics

Error Code (Hex)	Description	Possible causes / Comment	Remedy
9097	Invalid ID of the extension devices	A different extension module than the actual hardware structure is integrated in the project.	Check and correct the project or the hardware structure.
90a7	Incorrect DEVICE-ID in the parameter file	PSR-TRISAFE-S configured instead of PSR-TRISAFE-M	Check and correct the project or the hardware structure.
90a9	No parameter file present	No project was downloaded onto the IFS-CONFSTICK.	Download the project onto the IFS-CONFSTICK.
90aa	FRAM not connected	Faulty IFS-CONFSTICK / Faulty project	Reformat the IFS-CONFSTICK (SAFECONF function "Reset to factory default"). Use a new IFS-CONFSTICK.
90bf	Error state was set		Reformat the IFS-CONFSTICK (SAFECONF function "Reset to factory default").
90c5	Test of the voltage monitoring failed	<ul style="list-style-type: none"> - Surge voltage - Undervoltage 	Check and correct the supply voltage.
90c6	External FRAM stick not connected	IFS-CONFSTICK was removed and inserted during operating.	Observe the information in the user manual.
90e9	Test of the IO register failed in channel 1	Firmware error after 496 days	Carry out a firmware update.

8.2 PSR-TS-SDI8-SDIO4 and PSR-TS-SDOR4

Relevant error messages

Error Code (Hex)	Description	Possible causes / Comment	Remedy
0004	0-instead-of-1-error: Output cannot be activated	<ul style="list-style-type: none"> - Driver faulty - Peripheral fault (short circuit to 24 V) 	Eliminate the peripheral fault. Perform a voltage reset. Press the "Confirm" button (duration: min. 15 s).
000C	1-instead-of-0-error: Output cannot be deactivated	<ul style="list-style-type: none"> - Driver faulty - Peripheral fault (short circuit to GND) 	
0007	Clock signal error	<ul style="list-style-type: none"> - Cross-circuit at the inputs - Missing clock signal for IO0 to IO3 when these are parameterized as inputs 	

9 Revision history

Revision	Date	Contents
00	2017-10-13	First publication



SCATTERGOOD & JOHNSON LTD

ELECTRICAL ENGINEERING & FLUID CONTROL DISTRIBUTORS

Est.1899

At Scattergood & Johnson Ltd, we pride ourselves on being a technical distributor to specialist industries.

Working with a range of quality product suppliers across a number of specialist markets, we are not your average 'box shifter' - we are your technical and supply chain partner.

We fully support every product we sell - for free! Our internal team and external sales engineers can answer any product or application question, no matter the complexity.

Backing up this technical ability is a range of 50,000+ products available from stock for nationwide next day delivery (same day if required!), or you can collect what you need from any of our trade counters around the UK.

Select your specialist interest below to learn more about how we can help.



Online, In Branch and On the Road - Scattergood & Johnson Ltd, there when you need us.

www.scatts.co.uk