

## Panel feed-through - SACC-8P-DSI-M12MS/FS-M16 - 1551697

Please be informed that the data shown in this PDF Document is generated from our Online Catalog. Please find the complete data in the user's documentation. Our General Terms of Use for Downloads are valid (<http://phoenixcontact.com/download>)



Sensor/actuator control cabinet feed-through, male to female, 8-pos., M12, shielded, bipolar/screw mounting with M16 thread



### Key Commercial Data

Packing unit	1 pc
GTIN	 4 046356 156202
GTIN	4046356156202
Weight per Piece (excluding packing)	31.000 g
Custom tariff number	85366990
Country of origin	Czech Republic

### Technical data

#### Ambient conditions

Ambient temperature (operation)	-25 °C ... 85 °C (Plug / socket)
Degree of protection	IP67

#### General

Note	The electrical and mechanical data specified assume that the connector pair is correctly locked and mounted. If the connector is unlocked and if there is a danger of contamination, the connector must be sealed using a protective cap > IP54. Influences arising from litz wires, cables or PCB assembly must also be taken into consideration.
Rated current at 40 °C	2 A
Rated voltage	30 V
Rated surge voltage	0.8 kV
Number of positions	8
Insulation resistance	≥ 100 MΩ
Coding	A - standard
Standards/regulations	M12 connector IEC 61076-2-101

## Panel feed-through - SACC-8P-DSI-M12MS/FS-M16 - 1551697

### Technical data

#### General

Status display	No
Overvoltage category	II
Degree of pollution	3
Connection method	Individual wires
Insertion/withdrawal cycles	> 100
Torque	3 Nm ... 4 Nm (Installation-side)
Mounting type	Bipolar mounting M16 x 1.5

#### Material

Flammability rating according to UL 94	HB
Contact material	CuZn
Contact surface material	Au
Contact carrier material	PA 6.6
Material, knurls	Nickel-plated brass
Sealing material	FKM

#### Cable

Standards/specifications	M12 connector IEC 61076-2-101
Ambient temperature (operation)	-40 °C ... 85 °C (cable, fixed installation)
	-25 °C ... 85 °C (cable, flexible installation)

#### Standards and Regulations

Standard designation	M12 connector
Standards/regulations	IEC 61076-2-101
Flammability rating according to UL 94	HB

#### Environmental Product Compliance

	Lead 7439-92-1
China RoHS	Environmentally Friendly Use Period = 50
	For details about hazardous substances go to tab "Downloads", Category "Manufacturer's declaration"

### Drawings

# Panel feed-through - SACC-8P-DSI-M12MS/FS-M16 - 1551697

Schematic diagram

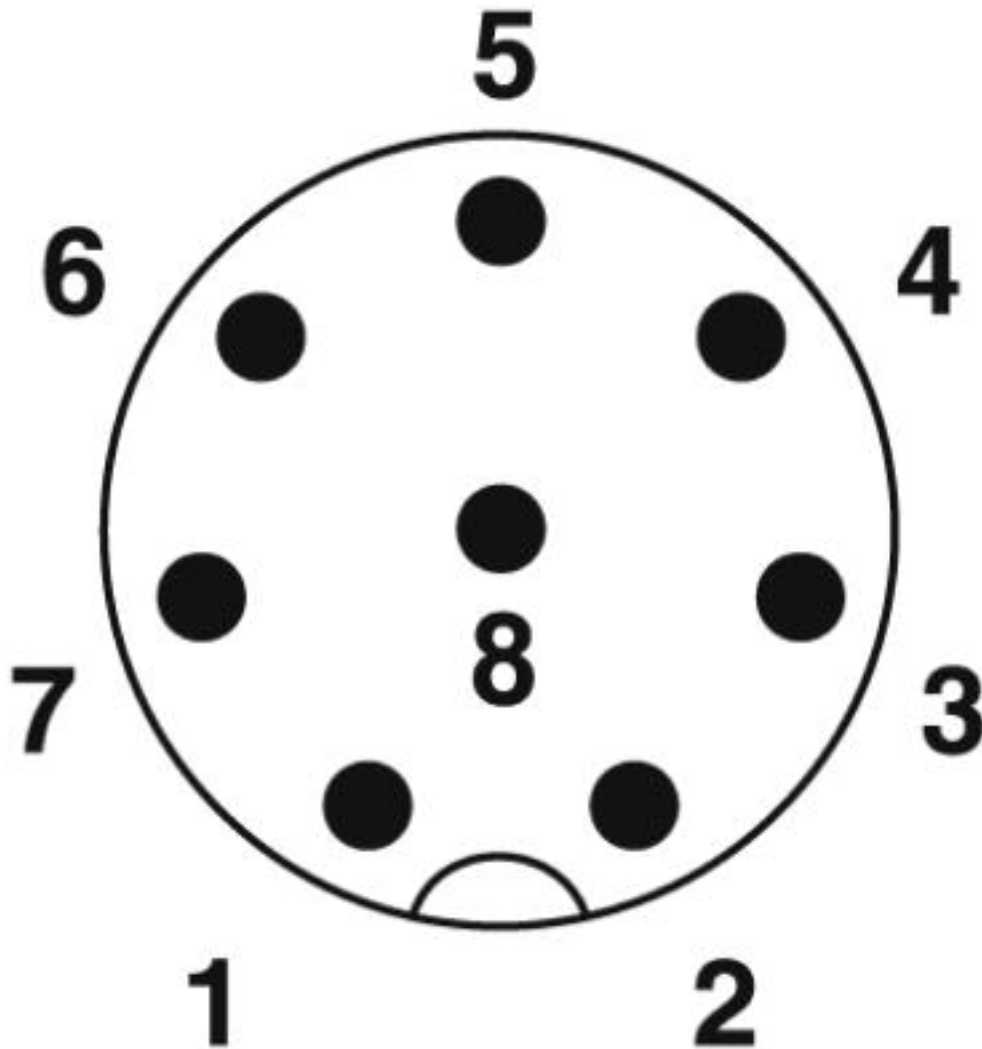

Pin assignment M12 plug, 8-pos., view plug side

# Panel feed-through - SACC-8P-DSI-M12MS/FS-M16 - 1551697

Schematic diagram

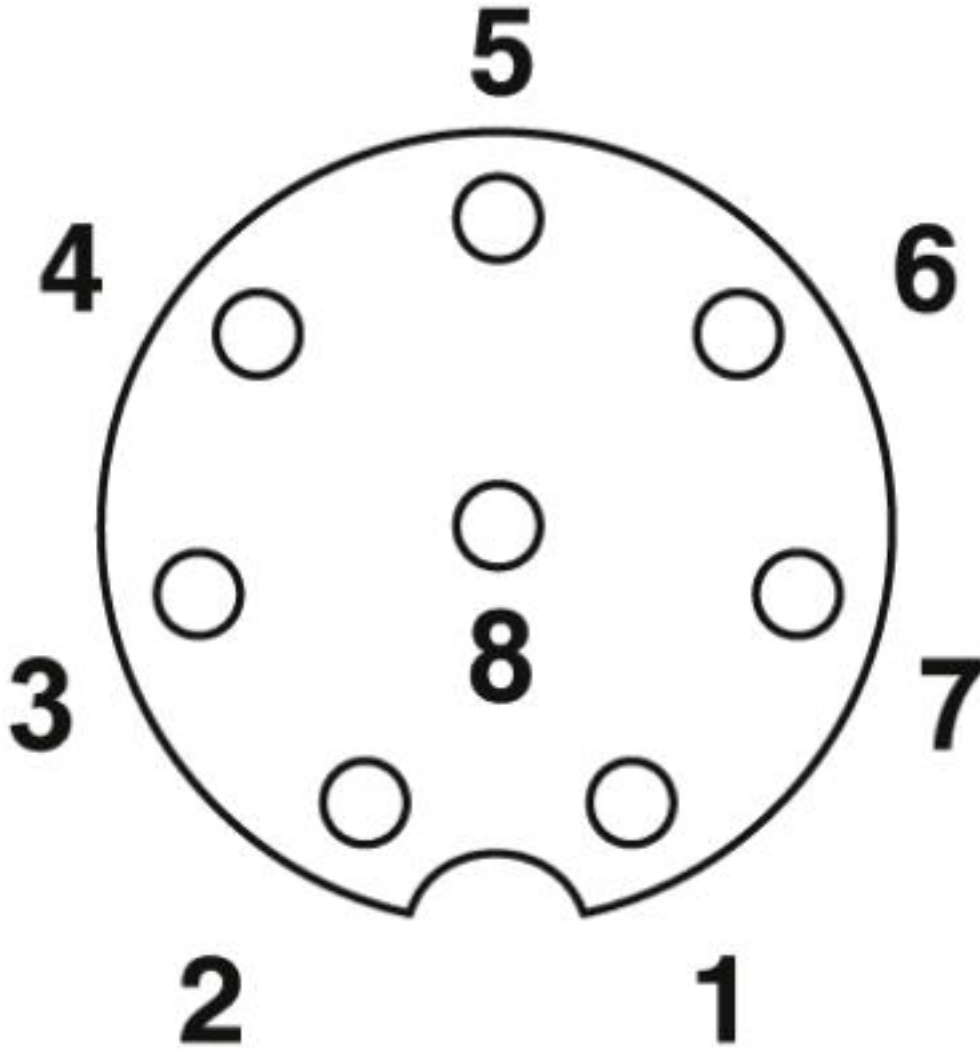

Pin assignment M12 socket, 8-pos., A-coded, view female side

## Panel feed-through - SACC-8P-DSI-M12MS/FS-M16 - 1551697

Dimensional drawing

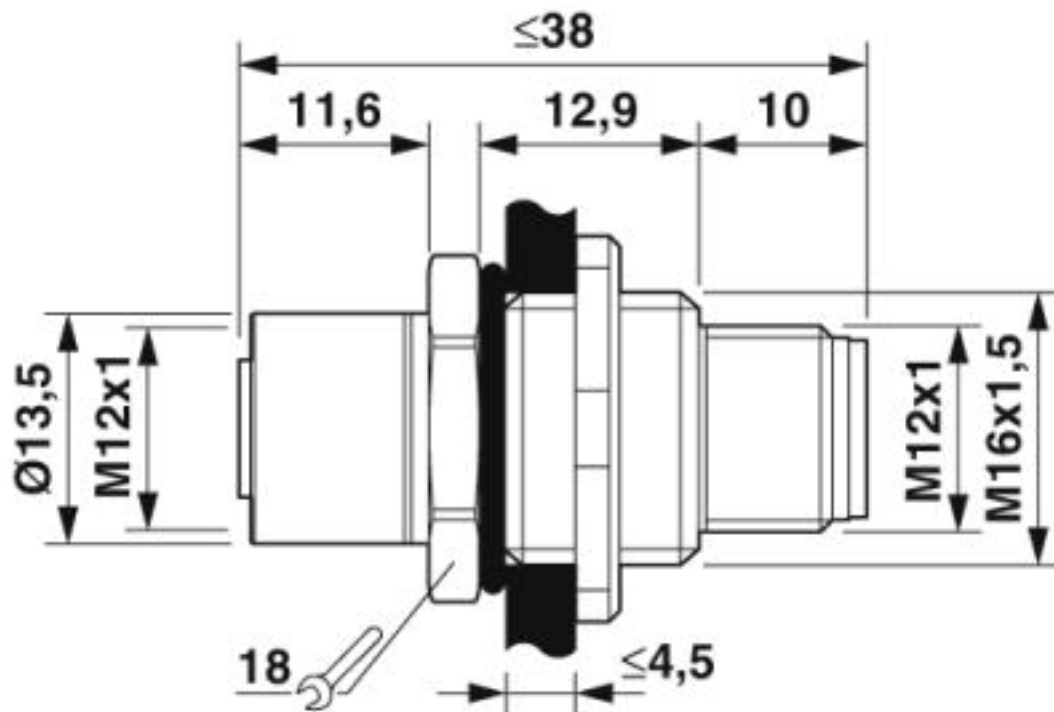

## Panel feed-through - SACC-8P-DSI-M12MS/FS-M16 - 1551697

Dimensional drawing

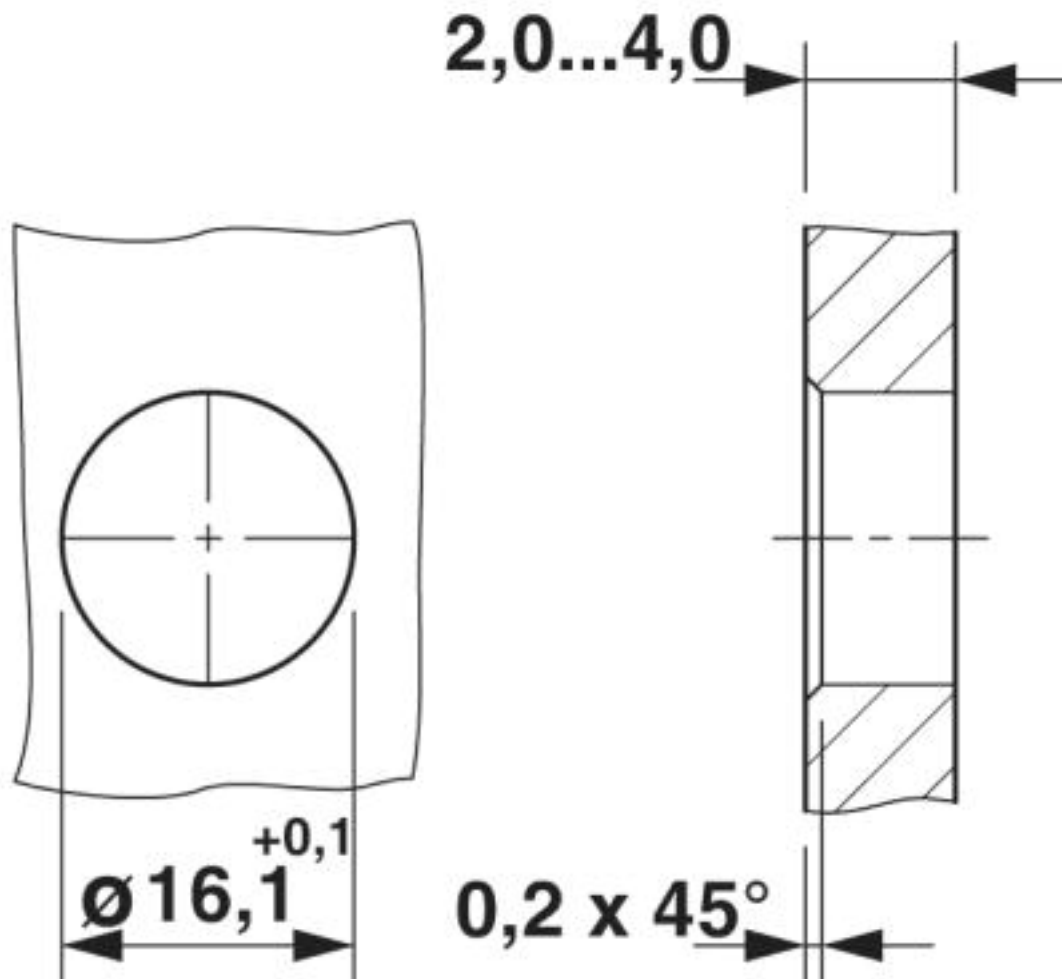

Mounting cutout

# Panel feed-through - SACC-8P-DSI-M12MS/FS-M16 - 1551697

Circuit diagram

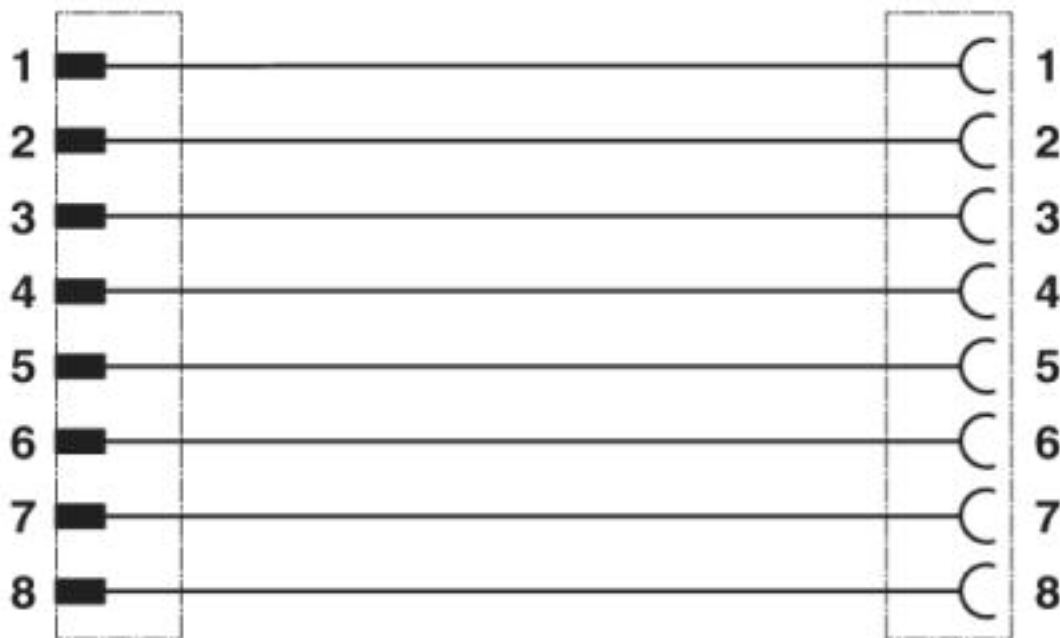

Contact assignment of the M12 plug and the M12 socket

## Classifications

### eCl@ss

eCl@ss 10.0.1	27440102
eCl@ss 4.0	27140800
eCl@ss 4.1	27140800
eCl@ss 5.0	27143400
eCl@ss 5.1	27143400
eCl@ss 6.0	27279200
eCl@ss 7.0	27440103
eCl@ss 8.0	27440103
eCl@ss 9.0	27440102

### ETIM

ETIM 3.0	EC002061
ETIM 4.0	EC002062
ETIM 5.0	EC002061
ETIM 6.0	EC002061

### UNSPSC

UNSPSC 6.01	31251501
UNSPSC 7.0901	31251501
UNSPSC 11	31251501

<https://www.phoenixcontact.com/gb/products/1551697>

## Panel feed-through - SACC-8P-DSI-M12MS/FS-M16 - 1551697

### Classifications

#### UNSPSC

UNSPSC 12.01	31251501
UNSPSC 13.2	39121413

### Approvals

#### Approvals

---

#### Approvals

#### EAC

---

#### Ex Approvals

---

### Approval details

EAC		B.01742
-----	---	---------

---

Phoenix Contact 2019 © - all rights reserved  
<http://www.phoenixcontact.com>



# SCATTERGOOD & JOHNSON LTD

ELECTRICAL ENGINEERING & FLUID CONTROL DISTRIBUTORS

Est.1899

At Scattergood & Johnson Ltd, we pride ourselves on being a technical distributor to specialist industries.

Working with a range of quality product suppliers across a number of specialist markets, we are not your average 'box shifter' - we are your technical and supply chain partner.

We fully support every product we sell - for free! Our internal team and external sales engineers can answer any product or application question, no matter the complexity.

Backing up this technical ability is a range of 50,000+ products available from stock for nationwide next day delivery (same day if required!), or you can collect what you need from any of our trade counters around the UK.

Select your specialist interest below to learn more about how we can help.



Online, In Branch and On the Road - Scattergood & Johnson Ltd, there when you need us.

# [www.scatts.co.uk](http://www.scatts.co.uk)