

# SUBCON-PLUS-PROFIB...



## Fast connectors for PROFIBUS systems

Data sheet  
101610\_en\_11

© PHOENIX CONTACT 2018-07-25

### 1 Description

The **SUBCON-PLUS-PROFIB...** D-SUB series is specifically designed for use in PROFIBUS systems up to 12 Mbps. Under field conditions, it enables the quick and easy connection of the incoming and outgoing bus line.

The product range includes ten fast connectors:

Connection	Cable entry	Programming interface	Reversible cable entry	Type	Order No.
Screw connection	Angled 35°	-	✓	SUBCON-PLUS-PROFIB/SC2	<a href="#">2708232</a>
		✓	✓	SUBCON-PLUS-PROFIB/PG/SC2	<a href="#">2708245</a>
	Angled 90°	-	-	SUBCON-PLUS-PROFIB/90/SC	<a href="#">2313698</a>
		✓	-	SUBCON-PLUS-PROFIB/90/PG/SC	<a href="#">2313708</a>
	Axial	-	-	SUBCON-PLUS-PROFIB/AX/SC	<a href="#">2744380</a>
Push-in spring connection	Axial	-	-	SUBCON-PLUS-PROFIB/AX	<a href="#">2744377</a>
	Angled 35°	-	✓	SUBCON-PLUS-PROFIB	<a href="#">2744348</a>
✓		-	SUBCON-PLUS-PROFIB/PG	<a href="#">2744403</a>	
IDC connection	Angled 90°	-	-	SUBCON-PLUS-PROFIB/90/IDC	<a href="#">2313672</a>
		✓	-	SUBCON-PLUS-PROFIB/90/PG/IDC	<a href="#">2313685</a>



#### **WARNING: Explosion hazard when used in potentially explosive areas**

Connectors with screw connection or Push-in spring connection: Follow the instructions provided here during installation and make sure you observe the safety notes.

The connectors with IDC connection have **no** ATEX approval and are suitable only for safe areas.



Make sure you always use the latest documentation.  
It can be downloaded at [phoenixcontact.net/products](http://phoenixcontact.net/products).

## Features

- All connectors can be used for PROFIBUS cables with a solid or stranded copper wire.
- All versions already have an integrated termination resistor. This is switched on externally via a slide switch. At the same time, the outgoing bus segment is switched off. This makes it easy to start up segment by segment while incorrect terminations are avoided.
- In addition, the connector housing with high-quality shielding ensures a high level of immunity to interference even at maximum data transmission speed.
- The connectors are designed for all standard PROFIBUS cables with an outside diameter of 8 mm (types A and B). When using Fast Connect cables, work is reduced to a minimum by using the PSM-STRIP-FC/PROFIB quick stripping tool.
- A special feature of the 35° angled connector is that the internal connection unit can be turned round. Whether the cable is to be inserted from the right or left can thus be decided on site.

## 2 Table of contents

1	Description.....	1
2	Table of contents .....	2
3	Ordering data.....	3
4	Connectors with screw connection or Push-in spring connection .....	5
4.1	Safety regulations and installation notes .....	5
4.2	Installation in zone 2.....	5
4.3	SUBCON-PLUS-PROFIB(/PG)/SC2 .....	6
4.4	SUBCON-PLUS-PROFIB/90(/PG)/SC .....	9
4.5	SUBCON-PLUS-PROFIB/AX(/SC).....	12
4.6	SUBCON-PLUS-PROFIB(/PG) .....	15
5	Connectors with IDC connection.....	18
6	Termination resistor .....	21

### 3 Ordering data

Connectors with screw connection	Type	Order No.	Pcs./Pkt.
D-SUB 9 connector, pin, 35° angled cable entry, bus system: PROFIBUS DP up to 12 Mbps, termination resistor can be switched on via slide switch, pin assignment: 3, 5, 6, 8	SUBCON-PLUS-PROFIB/SC2	2708232	1
D-SUB 9 connector, pin, 35° angled cable entry, bus system: PROFIBUS DP up to 12 Mbps with PG D-SUB socket for connecting a programming device, termination resistor can be switched on via slide switch, pin assignment: 3, 5, 6, 8	SUBCON-PLUS-PROFIB/PG/SC2	2708245	1
D-SUB 9 connector, pin, 90° angled cable entry, bus system: PROFIBUS DP up to 12 Mbps, termination resistor can be switched on via slide switch, pin assignment: 3, 5, 6, 8	SUBCON-PLUS-PROFIB/90/SC	2313698	1
D-SUB 9 connector, pin, 90° angled cable entry, bus system: PROFIBUS DP up to 12 Mbps with PG D-SUB socket for connecting a programming device, termination resistor can be switched on via slide switch, pin assignment: 3, 5, 6, 8	SUBCON-PLUS-PROFIB/90/PG/SC	2313708	1
D-SUB 9 connector, pin, axial version with two cable entries, bus system: PROFIBUS DP up to 12 Mbps, termination resistor can be switched on via slide switch, pin assignment: 3, 5, 6, 8	SUBCON-PLUS-PROFIB/AX/SC	2744380	1
Connectors with Push-in spring connection	Type	Order No.	Pcs./Pkt.
D-SUB 9 connector, pin, axial version with two cable entries, bus system: PROFIBUS DP up to 12 Mbps, termination resistor can be switched on via slide switch, pin assignment: 3, 5, 6, 8	SUBCON-PLUS-PROFIB/AX	2744377	1
D-SUB 9 connector, pin, two 35° angled cable entries, bus system: PROFIBUS DP up to 12 Mbps, termination resistor can be switched on via slide switch, pin assignment: 3, 5, 6, 8	SUBCON-PLUS-PROFIB	2744348	1
D-SUB 9 connector, pin, 35° angled cable entry, bus system: PROFIBUS DP up to 12 Mbps with PG D-SUB socket for connecting a programming device, termination resistor can be switched on via slide switch, pin assignment: 3, 5, 6, 8	SUBCON-PLUS-PROFIB/PG	2744403	1
Connectors with IDC connection	Type	Order No.	Pcs./Pkt.
D-SUB 9 connector, pin, 90° angled cable entry, bus system: PROFIBUS DP up to 12 Mbps, termination resistor can be switched on via slide switch, pin assignment: 3, 5, 6, 8	SUBCON-PLUS-PROFIB/90/IDC	2313672	1
D-SUB 9 connector, pin, 90° angled cable entry, bus system: PROFIBUS DP up to 12 Mbps with PG D-SUB socket for connecting a programming device, termination resistor can be switched on via slide switch, pin assignment: 3, 5, 6, 8	SUBCON-PLUS-PROFIB/90/PG/IDC	2313685	1

Accessories	Type	Order No.	Pcs./Pkt.
Quick stripping tool for PROFIBUS cable, Fast Connect type	PSM-STRIP-FC/PROFIB	2744623	1
Stripping pliers for PVC-insulated cables, stripping range: 0.08 ... 6 mm <sup>2</sup> , can cut wires up to 6 mm <sup>2</sup> stranded and 4 mm <sup>2</sup> solid	QUICK-WIREFOX 6	1204384	1
PROFIBUS cable, Fast Connect type, up to 12 Mbps (02YSY (ST)CY 1x2x22 AWG)	PSM-CABLE-PROFIB/FC	2744652	1
D-SUB 9 connector, pin, assignment: 3, 5, 6, 8 Two 90° angled M12 cable glands (B-coded) Bus system: PROFIBUS DP up to 12 Mbps Termination resistor via separate M12 terminator	SUBCON-PLUS-PROFIB/90/M12	2902318	1
D-SUB 9 connector, pin, assignment: 3, 5, 6, 8 Two 35° angled M12 cable glands (B-coded) Bus system: PROFIBUS DP up to 12 Mbps Termination resistor via separate M12 terminator	SUBCON-PLUS-PROFIB/35/M12	2902320	1
D-SUB 9 connector, pin, assignment: 3, 5, 6, 8 Two 180° angled (axial) M12 cable glands (B-coded) Bus system: PROFIBUS DP up to 12 Mbps Termination resistor via separate M12 terminator	SUBCON-PLUS-PROFIB/AX/M12	2902321	1

## 4 Connectors with screw connection or Push-in spring connection

### 4.1 Safety regulations and installation notes



**WARNING:**

Observe the following safety notes when using the connector.

- The category 3 device is designed for installation in zone 2 potentially explosive areas. It meets the requirements of EN 60079-0:2012+A11:2013 and EN 60079-15:2010.
- Installation, operation, and maintenance may only be carried out by qualified electricians. Follow the installation instructions as described. When installing and operating the device, the applicable regulations and safety directives (including national safety directives) as well as general technical regulations must be observed. The safety-related data is provided in the packing slip and on the certificates (conformity assessment, additional approvals where applicable).
- Do not repair the device yourself, but replace it with an equivalent device. Repairs may only be carried out by the manufacturer. The manufacturer is not liable for damage resulting from noncompliance.
- The IP20 degree of protection (IEC 60529/EN 60529) of the device is intended for a clean and dry environment. Do not subject the device to mechanical and/or thermal loads that exceed the specified limits.
- The device is not designed for installation in zone 22.
- If, however, you wish to use the device in zone 22, it must be installed in a housing that complies with IEC/EN 60079-31. Observe the maximum surface temperatures. Observe the requirements of IEC/EN 60079-14.

### 4.2 Installation in zone 2



**WARNING: Explosion hazard when used in potentially explosive areas**

Make sure that the following notes and instructions are observed.



**WARNING: Explosion hazard when used in potentially explosive areas**

D-SUB interfaces may only be connected or disconnected when the voltage is disconnected. Screw the D-SUB mounting screws tight on all connectors.

- Observe the specified conditions for use in potentially explosive areas!
- The device should be installed so that a degree of protection of at least IP54 is achieved in accordance with EN 60529. To this end, a suitable, approved housing that meets the requirements of EN60079-15 should be used.
- Only devices which are designed for operation in Ex zone 2 and are suitable for the conditions at the installation location may be connected to the circuits in zone 2.
- In potentially explosive areas, only connect and disconnect cables when the power is disconnected.
- The switches of the device that can be accessed may only be actuated when the power supply to the device is disconnected.
- Connection to the D-SUB interface is only permitted if the screw connection is fully tightened.
- Temporary malfunctions (transients) must not exceed the rated voltage by more than 40%.
- The device must be stopped and immediately removed from the Ex area if it is damaged, was subjected to an impermissible load, stored incorrectly or if it malfunctions.

4.3 SUBCON-PLUS-PROFIB(/PG)/SC2

**SUBCON-PLUS-PROFIB/SC2 (2708232)**

**SUBCON-PLUS-PROFIB/PG/SC2 (2708245)**

**Connection**

Connector connection	D-SUB 9 pin strip
Programming connection	D-SUB 9 socket strip (only for SUBCON-PLUS-PROFIB/PG/SC2)
Interface connection	Screw connection
Cable entry	Either left or right
Connection cross section of screw terminal blocks	
Solid	0.14 mm <sup>2</sup> ... 1.5 mm <sup>2</sup> (26-16 AWG)
Stranded	0.14 mm <sup>2</sup> ... 1 mm <sup>2</sup> (26-18 AWG)
Insertion cycles	>200
Cable diameter	8 mm (±0.4 mm)
Mounting screws	4-40 UNC
Maximum tightening torque	0.4 Nm
Pin assignment	3, 5, 6, 8

**General data**

Degree of protection	IP40
Housing material	ABS, metal-plated
Nominal current I <sub>N</sub>	100 mA
Max. operating voltage	5 V
Termination resistor	390 Ω - 220 Ω - 390 Ω (switchable)

**Ambient conditions**

Temperature range	
Operation	-20°C ... +75°C
Storage/transport	-25°C ... +80°C
Relative humidity	75% at 25°C

**Approvals**

UL approval	UL file no. 238705
ATEX	II 3 G Ex nA IIC T4 Gc X

Please follow the special installation instructions in the documentation (Page 5).

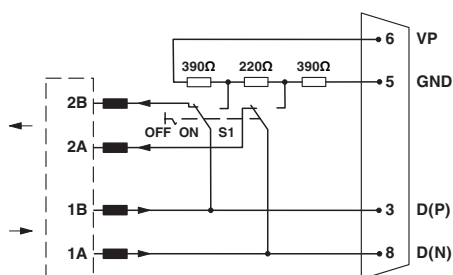

Figure 1 Circuit diagram

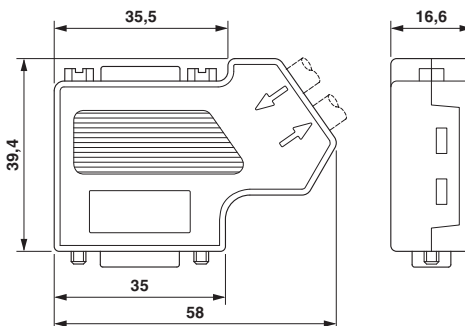

Figure 2 Dimensions

**SUBCON-PLUS-PROFIB/SC2 (2708232)**  
**SUBCON-PLUS-PROFIB/PG/SC2 (2708245)**

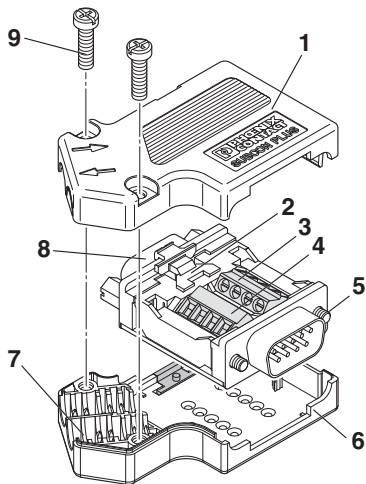

Figure 3 Structure

1	Upper housing part
2	Slide switch
3	Connection block for incoming bus
4	Connection block for outgoing bus
5	D-SUB mounting screws
6	Lower housing part
7	Strain relief
8	PG connection (only for SUBCON-PLUS-PROFIB/PG/SC2)
9	Housing screws

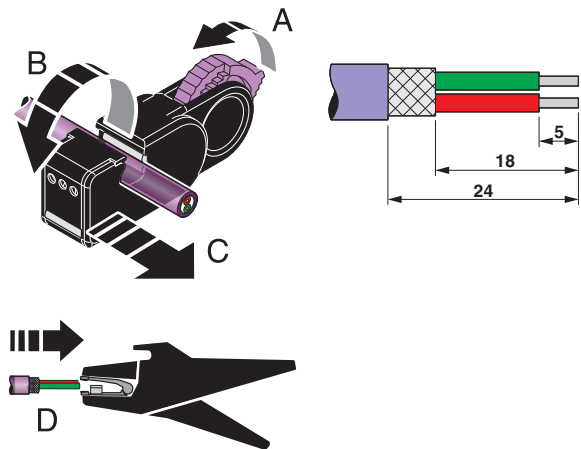

Figure 4 Stripping

The following stripping tools are recommended:

- PSM-STRIP-FC/PROFIB, Order No. 2744623
- QUICK WIREFOX 6, Order No. 1204384



**NOTE: Malfunction**

Observe the specified stripping lengths.

**SUBCON-PLUS-PROFIB/SC2 (2708232)****SUBCON-PLUS-PROFIB/PG/SC2 (2708245)****WARNING: Explosion hazard when used in potentially explosive areas**

D-SUB interfaces may only be connected or disconnected when the voltage is disconnected. Screw the D-SUB mounting screws tight on all connectors.

Cable entry can be from the right or left side. The connector supplied is pre-assembled for left-hand entry.

**Left-hand side cable entry**

Figure 5 Left-hand side cable entry

- Strip off the conductors (see Figure 4).
- Loosen the housing screw. Lift off the top cover.
- Screw the stripped conductors into the corresponding connection block contacts.
- Always connect the incoming bus line to terminal block connections 1A/1B (even at the start of the bus system).
- Connect the outgoing bus line to terminal connections 2A/2B. Observe the labeling of the connection terminal blocks.
- Finally, close and screw tight the housing half shells. This creates the shield connection and strain relief for the bus line.

**Right-hand side cable entry**

Figure 6 Right-hand side cable entry

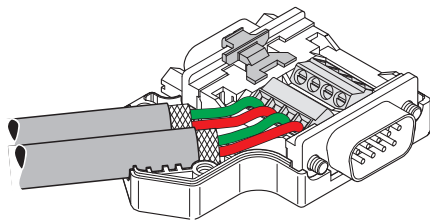
- Strip off the conductors (see Figure 4).
- Loosen the housing screw. Lift off the top cover.
- Lever the PCB out of the lower housing part near the cable entry. Use a screwdriver to do this.
- Insert the PCB in the upper housing part.
- Screw the stripped conductors into the corresponding connection block contacts.
- Always connect the incoming bus line to terminal block connections 1A/1B (even at the start of the bus system).
- Connect the outgoing bus line to terminal block connections 2A/2B. Observe the labeling of the connection terminal blocks.
- Finally, close and screw tight the housing half shells. This creates the shield connection and strain relief for the bus line.

## 4.4 SUBCON-PLUS-PROFIB/90(PG)/SC

**SUBCON-PLUS-PROFIB/90/SC (2313698)****SUBCON-PLUS-PROFIB/90/PG/SC (2313708)****Connection**

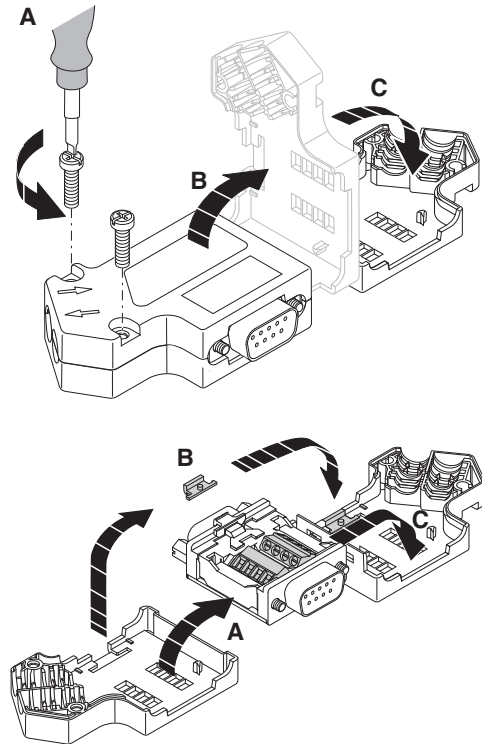
Connector connection	D-SUB 9 pin strip
Programming connection	D-SUB 9 socket strip (only for SUBCON-PLUS-PROFIB/90/PG/SC)
Interface connection	Screw connection
Cable entry	90° angled cable outlet
Connection cross section of screw terminal blocks	
Solid	0.14 mm <sup>2</sup> ... 1.5 mm <sup>2</sup> (26-16 AWG)
Stranded	0.14 mm <sup>2</sup> ... 1 mm <sup>2</sup> (26-18 AWG)
Insertion cycles	>200
Reconnection frequency	5
Cable diameter	8 mm (±0.4 mm)
Mounting screws	4-40 UNC
Maximum tightening torque	0.4 Nm
Pin assignment	3, 5, 6, 8



**General data**

Degree of protection	IP40
Housing material	ABS, metal-plated
Nominal current I <sub>N</sub>	100 mA
Max. operating voltage	5 V AC/DC
Termination resistor	390 Ω - 220 Ω - 390 Ω (switchable)

**Ambient conditions**

Temperature range	
Operation	-20°C ... +75°C
Storage/transport	-25°C ... +80°C
Relative humidity	75% at 25°C

**Approvals**

UL approval	 file no. E238705
ATEX	 II 3 G Ex nA IIC T4 Gc X
Please follow the special installation instructions in the documentation (Page 5)!	



All common Fast Connect PROFIBUS cables with solid and stranded single wires are supported, e.g., PSM-CABLE-PROFIB/FC (Order No. 2744652).

**SUBCON-PLUS-PROFIB/90/SC (2313698)**  
**SUBCON-PLUS-PROFIB/90/PG/SC (2313708)**

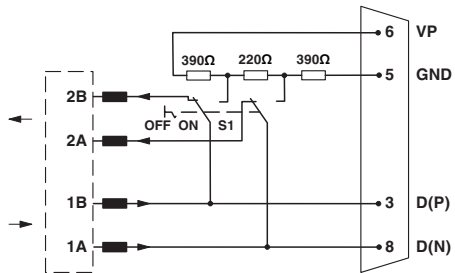

Figure 7 Circuit diagram

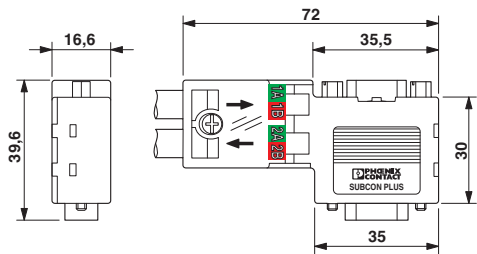

Figure 8 Dimensions

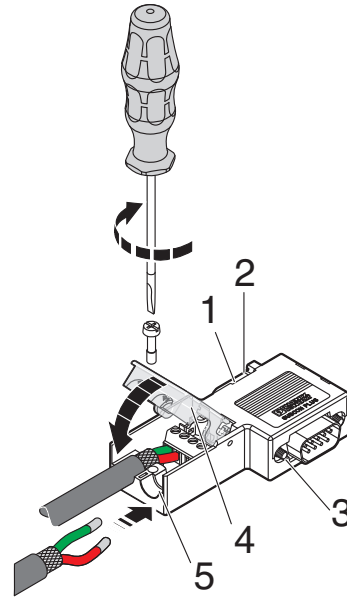

Figure 9 Structure

1	Slide switch
2	PG connection (only for SUBCON-PLUS-PROFIB/90/PG/SC)
3	D-SUB mounting screws
4	Terminal cover
5	Strain relief

SUBCON-PLUS-PROFIB/90/SC (2313698)

SUBCON-PLUS-PROFIB/90/PG/SC (2313708)

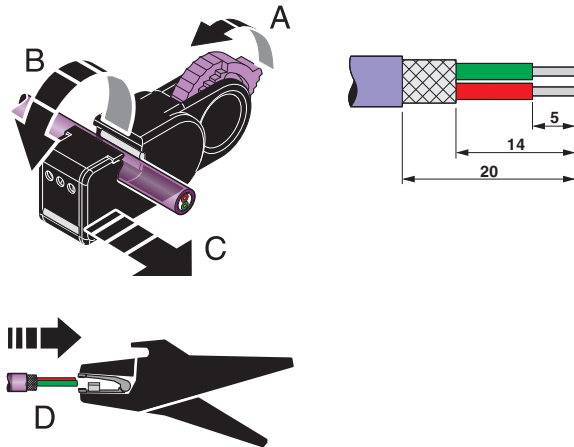

Figure 10 Stripping

The following stripping tools are recommended:

- PSM-STRIP-FC/PROFIB, Order No. 2744623
- QUICK WIREFOX 6, Order No. 1204384

**NOTE: Malfunction**

Observe the specified stripping lengths.

**WARNING: Explosion hazard when used in potentially explosive areas**

D-SUB interfaces may only be connected or disconnected when the voltage is disconnected. Screw the D-SUB mounting screws tight on all connectors.

The connector allows the incoming and outgoing bus lines to be quickly connected. The connector contacts are routed onto screw terminal blocks with colored labeling.

The integrated termination resistor can be switched and, when activated, simultaneously switches off the outgoing bus line. In this way, the bus system can be started up segment by segment.

The strain relief is integrated in the housing half-shells. It is designed for standard PROFIBUS cable type A. The additionally integrated SUBCON-PLUS-PROFIB/90/PG/SC programming connection allows a programming or service device to be connected without interrupting the bus operation.

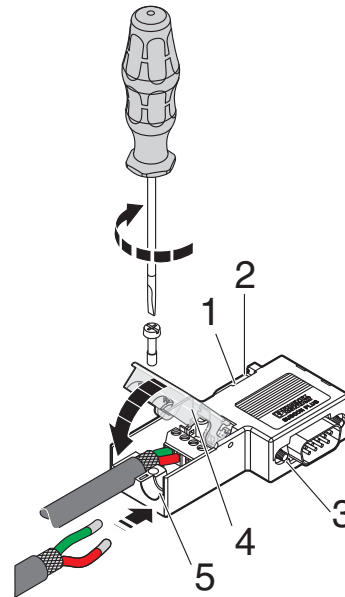

Figure 11 Connecting

- Strip off the conductors (see Figure 10).
- Remove the separating foil, if necessary.
- Insert the single wires into the connection terminal blocks as far as they will go.
- Always connect the incoming bus line to terminal block connections 1A/1B (even at the start of the bus system).
- Connect the outgoing bus line to terminal connections 2A/2B. Observe the labeling of the connection terminal blocks.
- Finally, mount and screw tight the connection terminal blocks. This creates the shield connection and strain relief for the bus line.

4.5 SUBCON-PLUS-PROFIB/AX(/SC)

	SUBCON-PLUS-PROFIB/AX/SC 2744380	SUBCON-PLUS-PROFIB/AX 2744377
<b>Connection</b>	Screw connection	Push-in spring connection
Connection cross section		
Solid	0.14 mm <sup>2</sup> ... 1.5 mm <sup>2</sup> (26-16 AWG)	0.12 mm <sup>2</sup> ... 0.5 mm <sup>2</sup> (26-20 AWG)
Stranded	0.14 mm <sup>2</sup> ... 1 mm <sup>2</sup> (26-18 AWG)	-
Connector connection	D-SUB 9 pin strip	
Cable entry	Axial	
Insertion cycles	>200	
Cable diameter	8 mm (±0.4 mm)	
Mounting screws	4-40 UNC	
Maximum tightening torque	0.4 Nm	
Pin assignment	3, 5, 6, 8	
<b>General data</b>		
Degree of protection	IP40	
Housing material	ABS, metal-plated	
Nominal current I <sub>N</sub>	100 mA	
Max. operating voltage	5 V	
Termination resistor	390 Ω - 220 Ω - 390 Ω (switchable)	
<b>Ambient conditions</b>		
Temperature range		
Operation	-20°C ... +75°C	
Storage/transport	-25°C ... +80°C	
Relative humidity	75% at 25°C	

**Approvals**

UL approval

 file no. E238705

ATEX

 II 3 G Ex nA IIC T4 Gc X

Please follow the special installation instructions in the documentation (Page 5)!

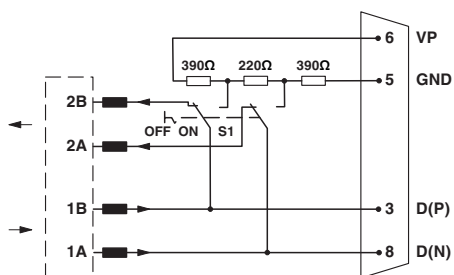

Figure 12 Circuit diagram

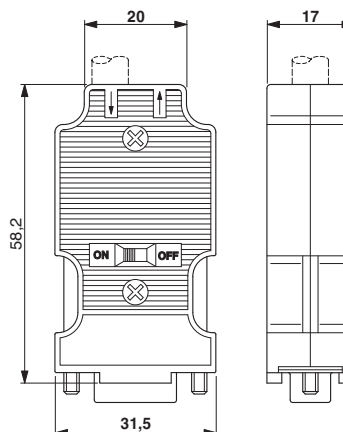

Figure 13 Dimensions

**SUBCON-PLUS-PROFIB/AX/SC (2744380)**

**SUBCON-PLUS-PROFIB/AX (2744377)**

**Screw connection**

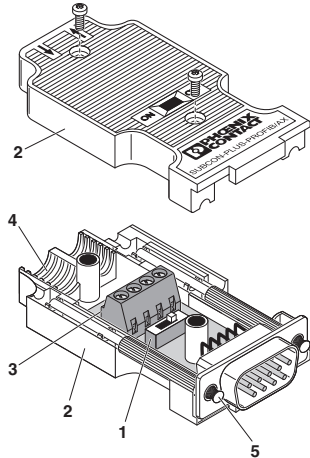

Figure 14 SUBCON-PLUS-PROFIB/AX/SC structure

1	Slide switch
2	Housing
3	Connection block
4	Strain relief
5	D-SUB mounting screw

**Push-in spring connection**

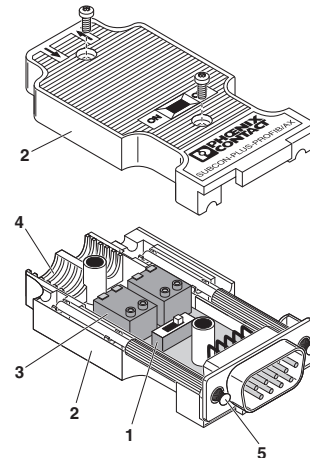

Figure 15 SUBCON-PLUS-PROFIB/AX structure

1	Slide switch
2	Housing
3	Connection block with release rocker
4	Strain relief
5	D-SUB mounting screw

SUBCON-PLUS-PROFIB/AX/SC (2744380)

SUBCON-PLUS-PROFIB/AX (2744377)

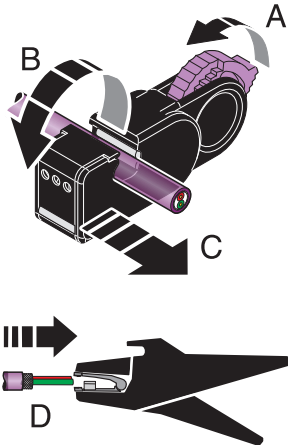

Figure 16 Stripping

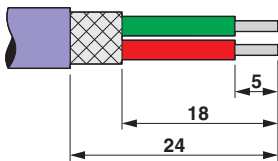

Figure 17 SUBCON-PLUS-PROFIB/AX/SC with screw connection

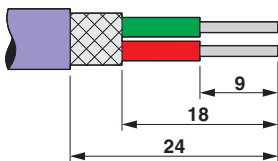

Figure 18 SUBCON-PLUS-PROFIB/AX with Push-in spring connection

The following stripping tools are recommended:

- PSM-STRIP-FC/PROFIB, Order No. 2744623
- QUICK WIREFOX 6, Order No. 1204384

**NOTE: Malfunction**

Observe the specified stripping lengths.

**WARNING: Explosion hazard when used in potentially explosive areas**

D-SUB interfaces may only be connected or disconnected when the voltage is disconnected. Screw the D-SUB mounting screws tight on all connectors.

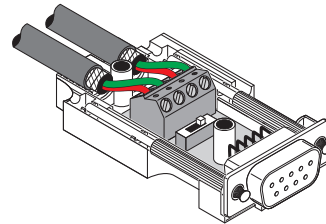

Figure 19 Connecting

**Screw connection (SUBCON-PLUS-PROFIB/AX/SC)**

- Strip off the conductors (see Figure 17).
- Loosen the housing screw. Lift off the top cover.
- Screw the stripped conductors into the corresponding connection block contacts.
- Always connect the incoming bus line to terminal block connections 1A/1B (even at the start of the bus system).
- Connect the outgoing bus line to terminal connections 2A/2B. Observe the labeling of the connection terminal blocks.

**Push-in spring connection (SUBCON-PLUS-PROFIB/AX)**

- Strip off the conductors (see Figure 18).
- Loosen the housing screw. Lift off the top cover.
- Insert the single wires into the connection terminal blocks as far as they will go. The conductors automatically make contact when inserted. To release the connection, press the orange release rocker.
- Always connect the incoming bus line to terminal block connections 1A/1B (even at the start of the bus system).
- Connect the outgoing bus line to terminal connections 2A/2B. Observe the labeling of the connection terminal blocks.

4.6 SUBCON-PLUS-PROFIB(/PG)

**SUBCON-PLUS-PROFIB (2744348)**

**SUBCON-PLUS-PROFIB/PG (2744403)**

**Connection**

Connector connection	D-SUB 9 pin strip
Programming connection	D-SUB 9 socket strip (only for SUBCON-PLUS-PROFIB/PG)
Cable entry	35°
Interface connection	Push-in spring connection
Connection cross-section: solid	0.12 mm <sup>2</sup> ... 0.5 mm <sup>2</sup> (26-20 AWG)
Stripping length	5 mm
Insertion cycles	>200
Cable diameter	8 mm (± 0.4 mm)
Mounting screws	4-40 UNC
Maximum tightening torque	0.4 Nm
Pin assignment	3, 5, 6, 8

**General data**

Degree of protection	IP40
Housing material	ABS, metal-plated
Nominal current I <sub>N</sub>	100 mA
Max. operating voltage	5 V
Termination resistor	390 Ω - 220 Ω - 390 Ω (switchable)

**Ambient conditions**

Temperature range	
Operation	-20°C ... +75°C
Storage/transport	-25°C ... +80°C

**Approvals**

UL approval	e <sub>UR</sub> file no. E238705
-------------	----------------------------------

ATEX

Please follow the special installation instructions in the documentation (Page 5)!

II 3 G Ex nA IIC T4 Gc X

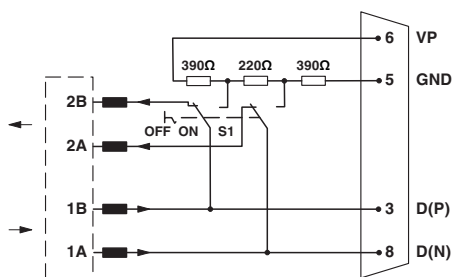

Figure 20 Circuit diagram

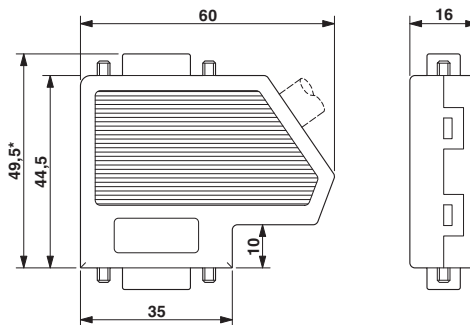

Figure 21 Dimensions

**SUBCON-PLUS-PROFIB (2744348)**

**SUBCON-PLUS-PROFIB/PG (2744403)**

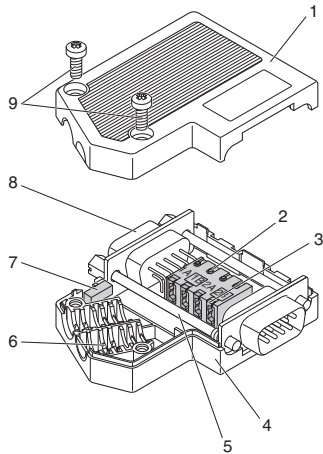

Figure 22 Structure

1	Upper housing part
2	Connection block
3	Release rocker
4	Lower housing part
5	D-SUB mounting screw
6	Strain relief
7	Slide switch
8	PG connection (only for SUBCON-PLUS-PROFIB/PG)
9	Housing screw

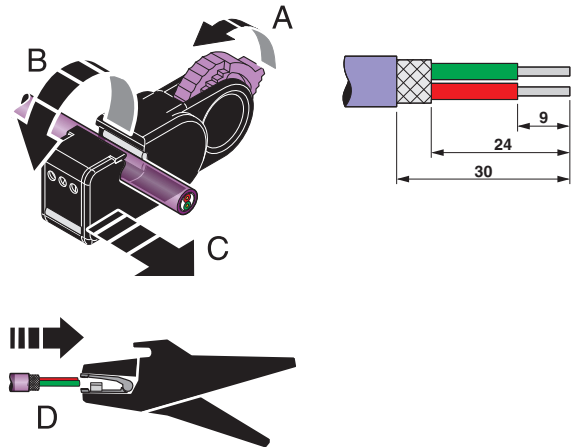

Figure 23 Stripping

The following stripping tools are recommended:

- PSM-STRIP-FC/PROFIB, Order No. 2744623
- QUICK WIREFOX 6, Order No. 1204384



**NOTE: Malfunction**

Observe the specified stripping lengths.

**SUBCON-PLUS-PROFIB (2744348)****SUBCON-PLUS-PROFIB/PG (2744403)****WARNING: Explosion hazard when used in potentially explosive areas**

D-SUB interfaces may only be connected or disconnected when the voltage is disconnected. Screw the D-SUB mounting screws tight on all connectors.



The SUBCON-PLUS-PROFIB/PG (2744403) with programming interface is designed for left-hand side cable entry. The cable entry is not reversible.

For SUBCON-PLUS-PROFIB, the cable entry can be from the right or left side. The connector supplied is pre-assembled for left-hand entry.

**Left-hand side cable entry**

Figure 24 Left-hand side cable entry

- Strip off the conductors (see Figure 23).
- Loosen the housing screw. Lift off the top cover.
- Insert the single wires into the connection terminal blocks as far as they will go. The conductors automatically make contact when inserted. To release the connection, press the orange release rocker.
- Always connect the incoming bus line to terminal block connections 1A/1B (even at the start of the bus system).
- Connect the outgoing bus line to terminal connections 2A/2B. Observe the labeling of the connection terminal blocks.
- Finally, close and screw tight the housing half shells. This creates the shield connection and strain relief for the bus line.

**Right-hand side cable entry (only 2744348)**

Figure 25 Removing and turning around the connection block.

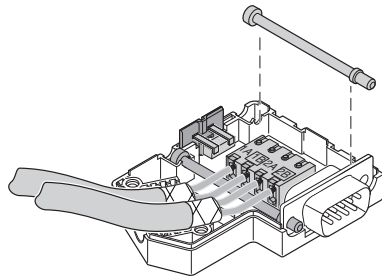
- Strip off the conductors (see Figure 23).
- Loosen the housing screw. Lift off the top cover.
- Lever the PCB out of the lower housing part near the rivets. Use a screwdriver to do this.
- Remove the connection block. Rotate it 180°.
- Insert the single wires into the connection terminal blocks as far as they will go. The conductors automatically make contact when inserted. To release the connection, press the orange release rocker.
- Always connect the incoming bus line to terminal block connections 1A/1B (even at the start of the bus system).
- Connect the outgoing bus line to terminal connections 2A/2B. Observe the labeling of the connection terminal blocks.
- Finally, close and screw tight the housing half shells. This creates the shield connection and strain relief for the bus line.

## 5 Connectors with IDC connection

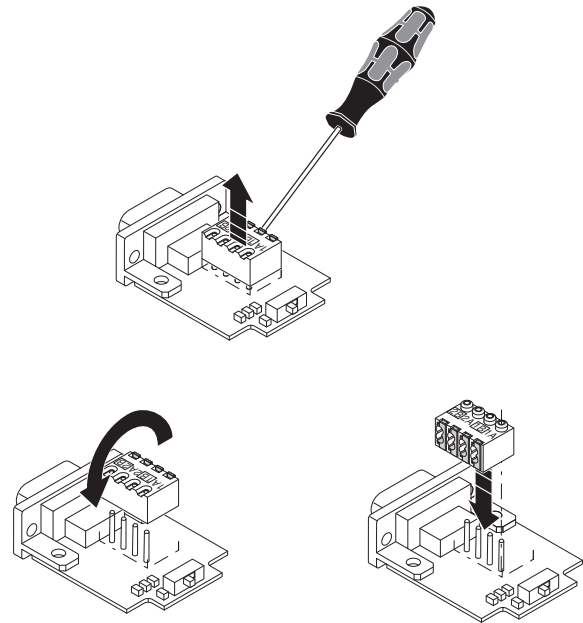

The connectors with IDC connection have **no** ATEX approval and are suitable only for safe areas.

- Installation, operation, and maintenance may only be carried out by qualified electricians. Follow the installation instructions as described.
- Do not repair the device yourself, but replace it with an equivalent device. Repairs may only be carried out by the manufacturer. The manufacturer is not liable for damage resulting from noncompliance.

### SUBCON-PLUS-PROFIB/90/IDC (2313672)

### SUBCON-PLUS-PROFIB/90/PG/IDC (2313685)

#### Connection

Connector connection	D-SUB 9 pin strip
Programming connection	D-SUB 9 socket strip (only for SUBCON-PLUS-PROFIB/90/PG/IDC)
Interface connection	IDC fast connection (insulation displacement connection technology)
Cable entry	90° angled cable outlet
Connection cross section of IDC terminal blocks (single-wire)	
Solid	0.32 mm <sup>2</sup> ... 1 mm <sup>2</sup> (22-18 AWG)
Stranded	0.32 mm <sup>2</sup> ... 1 mm <sup>2</sup> (22 AWG ... 18 AWG)
Insertion cycles	>200
Cable diameter	8 mm (±0.4 mm)
Mounting screws	4-40 UNC
Maximum tightening torque	0.4 Nm
Pin assignment	3, 5, 6, 8

#### General data

Degree of protection	IP40
Housing material	ABS, metal-plated
Nominal current $I_N$	100 mA
Nominal voltage $U_N$	5 V AC/DC
Termination resistor	390 Ω - 220 Ω - 390 Ω (switchable)

#### Ambient conditions

Temperature range	
Operation	-20°C ... +75°C
Storage/transport	-25°C ... +80°C
Relative humidity	75% at 25°C

#### Approvals

UL approval	file no. E238705
-------------	------------------



All common Fast Connect PROFIBUS cables with solid and stranded single wires are supported, e.g., PSM-CABLE-PROFIB/FC (Order No. 2744652).

SUBCON-PLUS-PROFIB/90/IDC (2313672)

SUBCON-PLUS-PROFIB/90/PG/IDC (2313685)

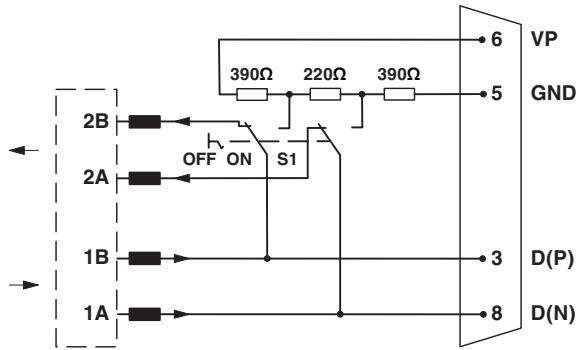

Figure 26 Circuit diagram

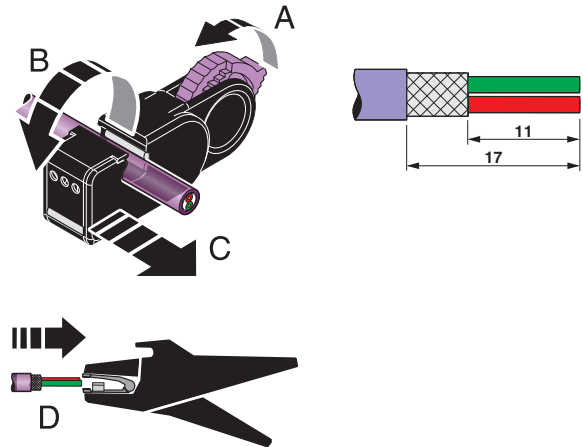

Figure 28 Stripping

The following stripping tools are recommended:

- PSM-STRIP-FC/PROFIB, Order No. 2744623
- QUICK WIREFOX 6, Order No. 1204384



**NOTE: Malfunction**

Observe the specified stripping lengths.

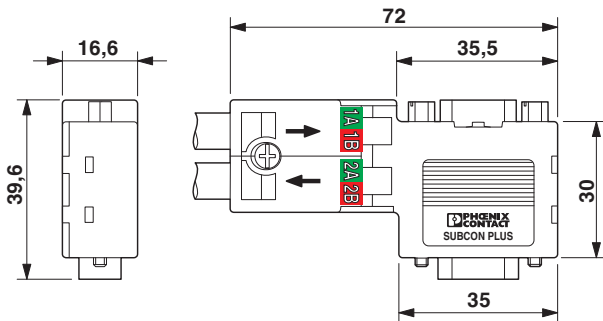

Figure 27 Dimensions

**SUBCON-PLUS-PROFIB/90/IDC (2313672)****SUBCON-PLUS-PROFIB/90/PG/IDC (2313685)**

The connector allows the incoming and outgoing bus lines to be quickly connected. The connector contacts are routed onto IDC terminal blocks with color labeling.

The integrated termination resistor can be switched and, when activated, simultaneously switches off the outgoing bus line. In this way, the bus system can be started up segment by segment.

The strain relief is integrated in the housing half-shells. It is designed for standard PROFIBUS cable type A. The additionally integrated SUBCON-PLUS-PROFIB/90/PG/IDC programming connection allows a programming or service device to be connected without interrupting the bus operation.

- Strip off the conductors (see Figure 28).
- Remove the separating foil, if necessary.
- Insert the single wires into the connection terminal blocks as far as they will go.
- Always connect the incoming bus line to terminal block connections 1A/1B (even at the start of the bus system).
- Connect the outgoing bus line to terminal connections 2A/2B. Observe the labeling of the connection terminal blocks.
- Then close and screw on the terminal cover. This creates the shield connection and strain relief for the bus line.

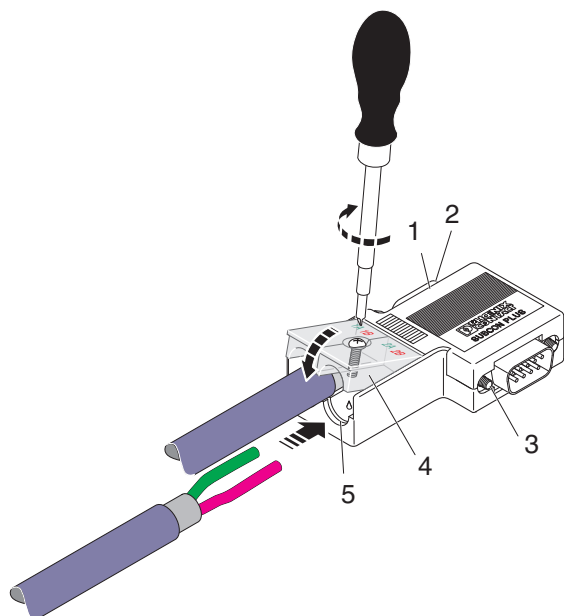

Figure 29 Connecting

1	Slide switch
2	PG connection (only for SUBCON-PLUS-PROFIB/90/PG/IDC)
3	D-SUB mounting screw
4	Terminal cover
5	Strain relief

## All versions

## 6 Termination resistor

Note regarding connectors with screw connection or Push-in spring connection:



**WARNING: Explosion hazard when used in potentially explosive areas**

The switches of the device that can be accessed may only be actuated when the power supply to the device is disconnected.

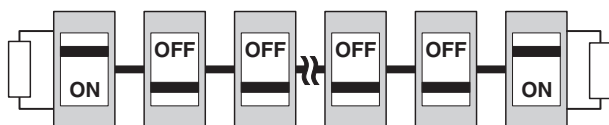

Figure 30 Termination resistor

- Use the slide switch to activate the termination resistors at the start and end points of the bus system. At the same time, the connection terminal blocks (2A/2B) for the outgoing bus cable are switched off.



The termination resistor must be deactivated at all other nodes in the bus system.

Length according to PROFIBUS specification

Transmission speed	Segment length	Permissible branch lengths per bus segment
9.6 kbps	1200 m	32 x 3 m
19.2 kbps	1200 m	32 x 3 m
45.45 kbps	1200 m	32 x 3 m
93.75 kbps	1200 m	32 x 3 m
187.5 kbps	1200 m	32 x 2 m
500 kbps	400 m	32 x 1 m
1500 kbps	200 m	32 x 0.3 m
3000 kbps ... 12000 kbps	100 m	Not permitted

### Minimum cable length between two PROFIBUS-DP bus devices

The PROFIBUS guideline recommends a minimum cable length of one meter. Due to the integrated inductances, you are not obliged to follow this recommendation. You can also install shorter cables between the PROFIBUS devices.



# SCATTERGOOD & JOHNSON LTD

ELECTRICAL ENGINEERING & FLUID CONTROL DISTRIBUTORS

Est.1899

At Scattergood & Johnson Ltd, we pride ourselves on being a technical distributor to specialist industries.

Working with a range of quality product suppliers across a number of specialist markets, we are not your average 'box shifter' - we are your technical and supply chain partner.

We fully support every product we sell - for free! Our internal team and external sales engineers can answer any product or application question, no matter the complexity.

Backing up this technical ability is a range of 50,000+ products available from stock for nationwide next day delivery (same day if required!), or you can collect what you need from any of our trade counters around the UK.

Select your specialist interest below to learn more about how we can help.

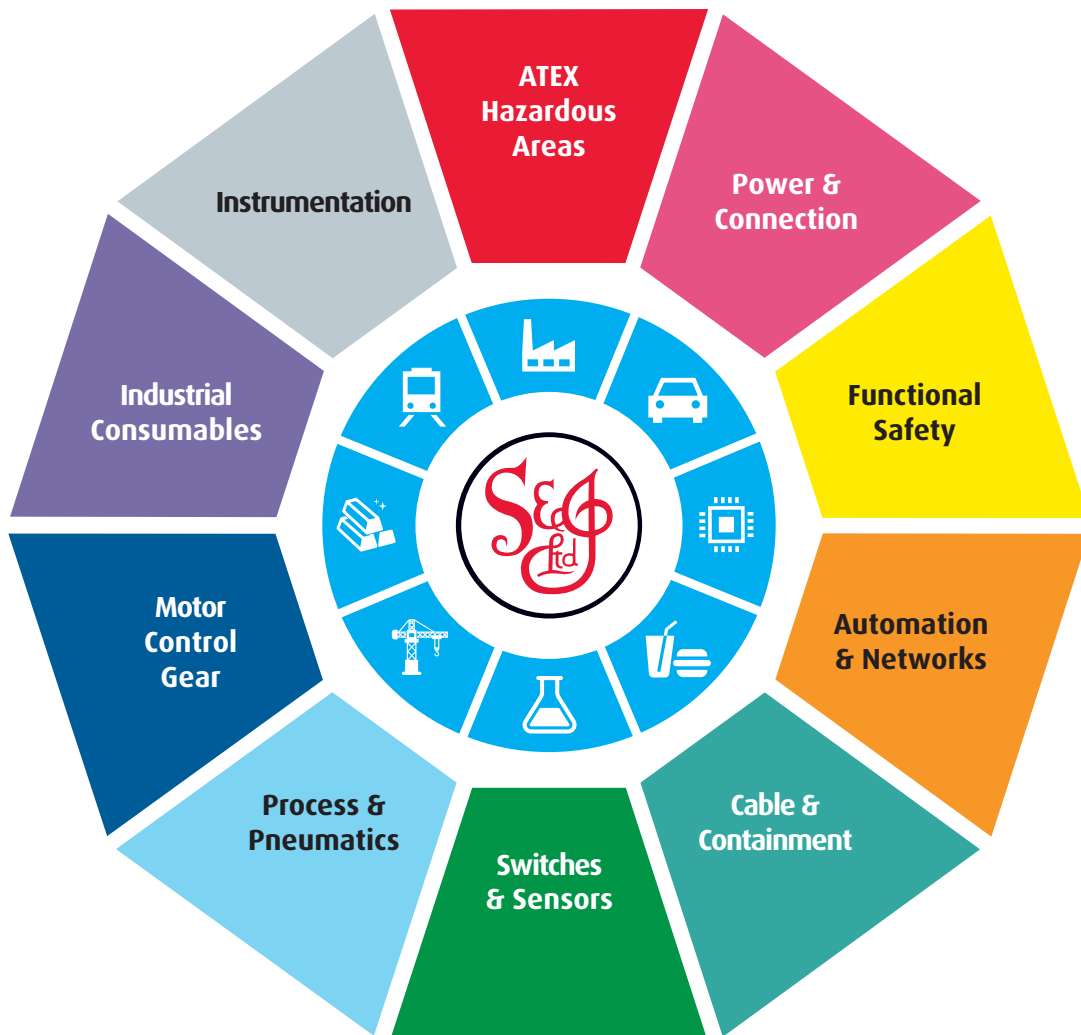

Online, In Branch and On the Road - Scattergood & Johnson Ltd, there when you need us.

# [www.scatts.co.uk](http://www.scatts.co.uk)