

Patch panels - FL-PP-RJ45-LSA - 2901645

Please be informed that the data shown in this PDF Document is generated from our Online Catalog. Please find the complete data in the user's documentation. Our General Terms of Use for Downloads are valid (<http://phoenixcontact.com/download>)



Patch panel, one RJ45 socket to 8 IDC connection terminal blocks (1:1 assignment), CAT5e, 10/100/1000 Mbps, DIN rail mounting, IP20, option of shield contacting on DIN rail via jumpers

Your advantages

- Safe shield connection to ground potential
- CAT5e
- Mounting on a DIN rail
- 10/100/1000 Mbps
- Optional shield connection via jumpers
- Shipbuilding approval in accordance with DNV GL



Key Commercial Data

Packing unit	10 pc
Minimum order quantity	10 pc
GTIN	 4 046356 622790
GTIN	4046356622790
Weight per Piece (excluding packing)	56.310 g
Custom tariff number	85366990
Country of origin	Germany

Technical data

Dimensions

Width	29 mm
Height	90 mm
Depth	53 mm

Ambient conditions

Ambient temperature (operation)	-25 °C ... 70 °C
Ambient temperature (storage/transport)	-25 °C ... 85 °C

Patch panels - FL-PP-RJ45-LSA - 2901645

Technical data

Ambient conditions

Permissible humidity (operation)	25 % ... 95 % (non-condensing)
Degree of protection	IP20

General

Net weight	56.31 g
Housing material	PVC / PA
Color	green
MTBF	6702 Years (Telcordia standard, 25°C temperature, 21% operating cycle (5 days a week, 8 hours a day))
	2962 Years (Telcordia standard, 40°C temperature, 34.25% operating cycle (5 days a week, 12 hours a day))

Serial interface

Interface 1	Ethernet interface, 10/100/1000Base-T(X) according to IEEE 802.3u
No. of ports	1
Connection method	LSA
Transmission length	100 m (including patch cables)
Conductor cross section solid min.	0.128 mm ²
Conductor cross section solid max.	0.325 mm ²
Conductor cross section flexible min.	0.128 mm ²
Conductor cross section flexible max.	0.325 mm ²
Conductor cross section AWG min.	26
Conductor cross section AWG max.	22
Pin assignment	1:1
Serial transmission speed	10/100/1000 Mbps
Interface 2	Ethernet interface, 10/100/1000Base-T(X) according to IEEE 802.3u
No. of ports	1
Connection method	RJ45 CAT5e

Conformance/approvals

Designation	EAC
Identification	EAC
Designation	Corrosive gas test
Identification	ISA-S71.04-1985 G3 Harsh Group A
Designation	Shipbuilding
Identification	DNV GL
Temperature	B
Humidity	A
Vibration	A
EMC	B
Enclosure	Required protection according to the Rules shall be provided upon installation on board

Standards and Regulations

Patch panels - FL-PP-RJ45-LSA - 2901645

Technical data

Standards and Regulations

Type of test	Vibration resistance in acc. with EN 60068-2-6/IEC 60068-2-6
Test result	5g, 10...150 Hz, 2.5 h, in XYZ direction
Type of test	Shock in acc. with EN 60068-2-27/IEC 60068-2-27
Test result	25g, 11 ms period, half-sine shock pulse

Environmental Product Compliance

REACH SVHC	Lead 7439-92-1
China RoHS	Environmentally Friendly Use Period = 50
	For details about hazardous substances go to tab "Downloads", Category "Manufacturer's declaration"

Drawings

Dimensional drawing

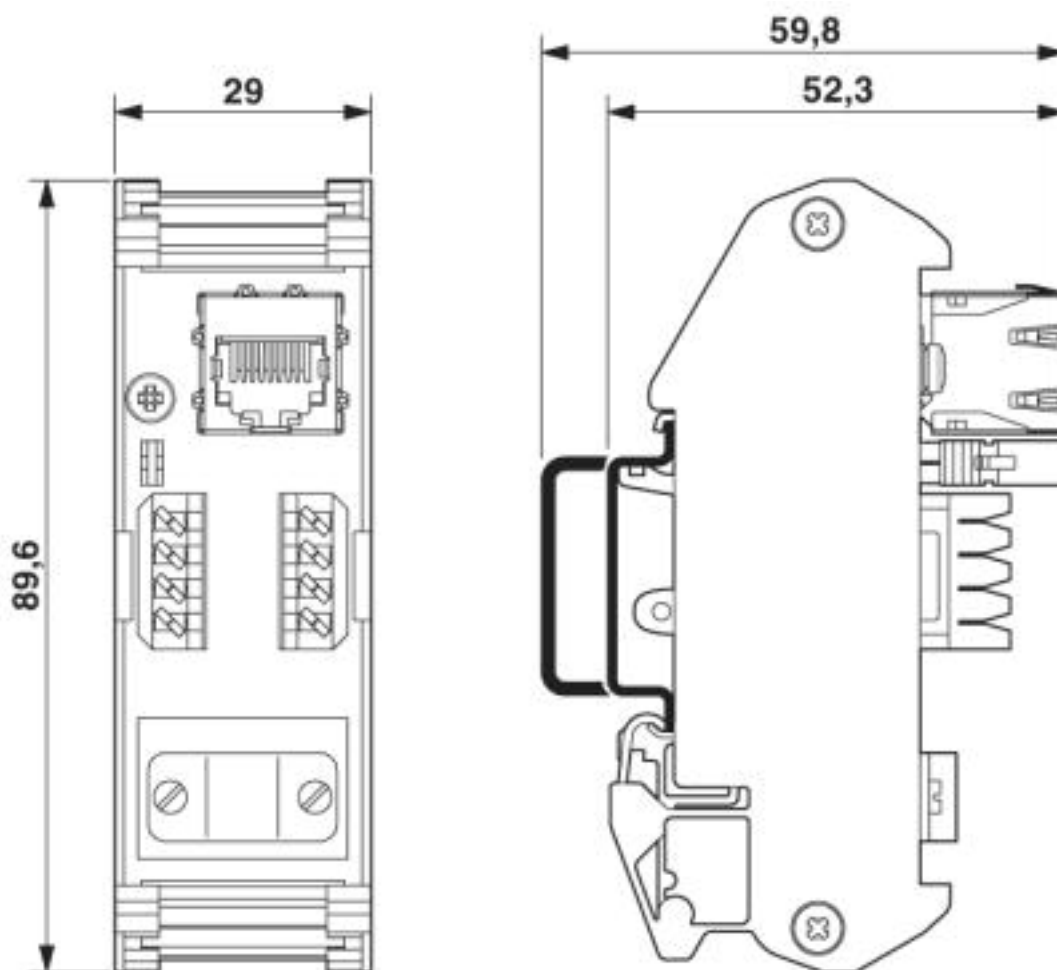

Patch panels - FL-PP-RJ45-LSA - 2901645

Circuit diagram

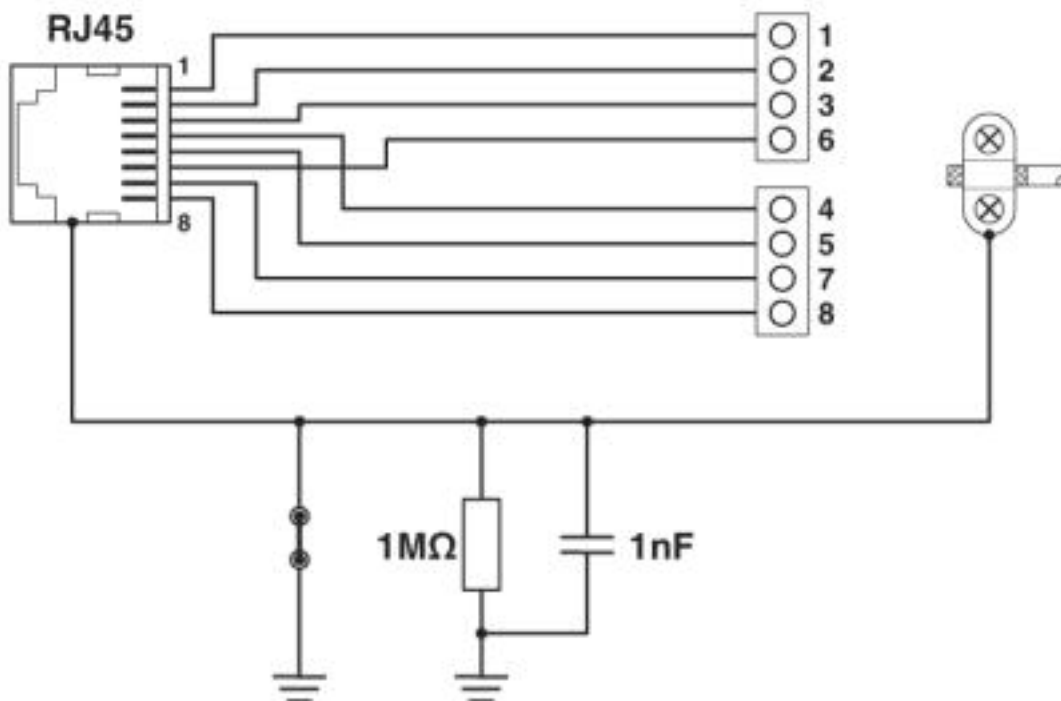

Schematic diagram

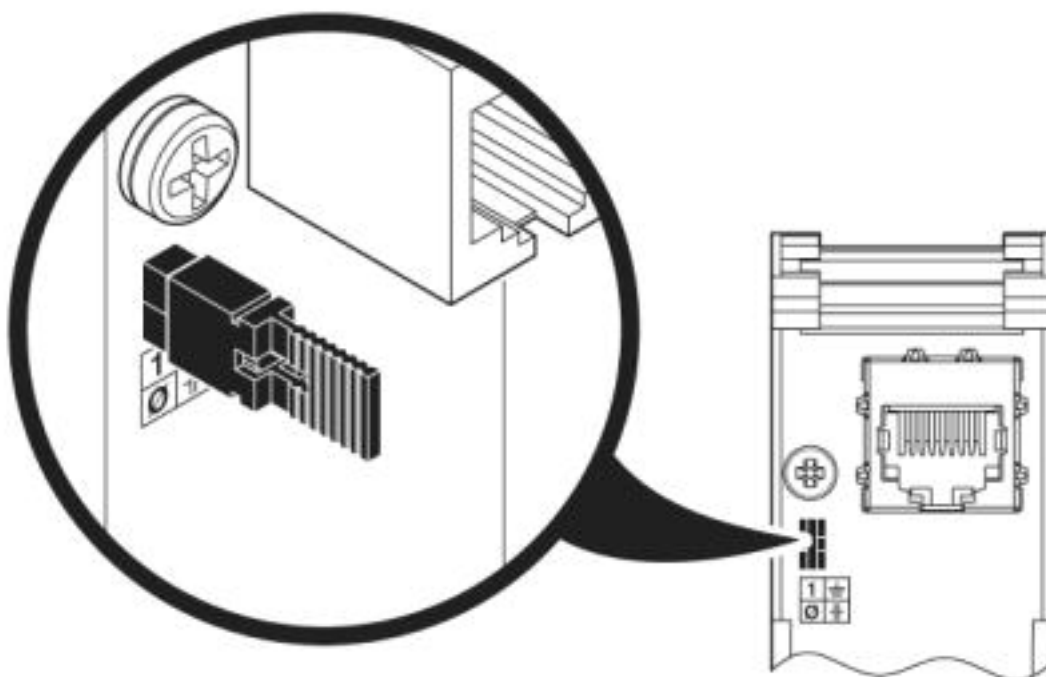

Shield connection direct to PE

Patch panels - FL-PP-RJ45-LSA - 2901645

Schematic diagram

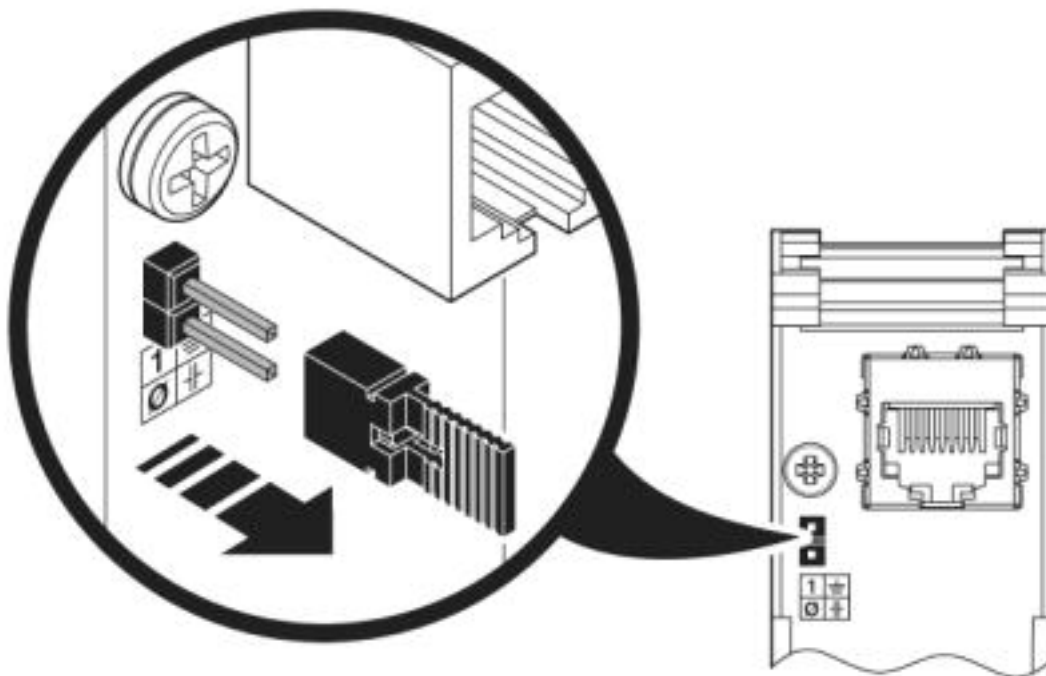

Shield connection to PE via RC element

Classifications

eCl@ss

eCl@ss 4.0	27230200
eCl@ss 4.1	27230200
eCl@ss 5.0	27230200
eCl@ss 5.1	27230200
eCl@ss 6.0	19170100
eCl@ss 7.0	19170112
eCl@ss 8.0	19170112
eCl@ss 9.0	19170112

ETIM

ETIM 3.0	EC000313
ETIM 4.0	EC001128
ETIM 5.0	EC002599
ETIM 6.0	EC002599
ETIM 7.0	EC002599

UNSPSC

UNSPSC 6.01	30211506
UNSPSC 7.0901	39121008

<https://www.phoenixcontact.com/gb/products/2901645>



Patch panels - FL-PP-RJ45-LSA - 2901645

Classifications

UNSPSC

UNSPSC 11	39121008
UNSPSC 12.01	39121008
UNSPSC 13.2	26121604

Approvals

Approvals

Approvals

DNV GL / EAC

Ex Approvals

Approval details

DNV GL		https://approvalfinder.dnvgl.com/	TAA00001KR
--------	---	---	------------

EAC			EAC-Zulassung
-----	---	--	---------------

Phoenix Contact 2019 © - all rights reserved
<http://www.phoenixcontact.com>



SCATTERGOOD & JOHNSON LTD

ELECTRICAL ENGINEERING & FLUID CONTROL DISTRIBUTORS

Est.1899

At Scattergood & Johnson Ltd, we pride ourselves on being a technical distributor to specialist industries.

Working with a range of quality product suppliers across a number of specialist markets, we are not your average 'box shifter' - we are your technical and supply chain partner.

We fully support every product we sell - for free! Our internal team and external sales engineers can answer any product or application question, no matter the complexity.

Backing up this technical ability is a range of 50,000+ products available from stock for nationwide next day delivery (same day if required!), or you can collect what you need from any of our trade counters around the UK.

Select your specialist interest below to learn more about how we can help.



Online, In Branch and On the Road - Scattergood & Johnson Ltd, there when you need us.

www.scatts.co.uk