

# FL-PP-RJ45... / FL CAT5...

## Ethernet patch panel

Data sheet  
104622\_en\_05

© PHOENIX CONTACT 2017-01-31



### 1 Description

**FL-PP-RJ45... / FL CAT5...** patch panels provide the transition from the field cabling to the cabling inside the control cabinet.

The patch panel is connected to the end device via the RJ45 socket using a pre-assembled patch cable. Pre-assembled patch cables in different connection lengths from 0.24 m to 20 m are available for this.

The field cabling is applied easily to spring, screw, or LSA connection terminal blocks, depending on the version. The individual terminal blocks are clearly labeled for connection according to Ethernet standard TIA 568 A and B as well as PROFINET. There is no longer any need to spend time and effort crimping an RJ45 connector to the field line.

### Features

- CAT5e
- 8-pin assignment: 1:1
- 10/100/1000 Mbps
- Mounting on a DIN rail
- Safe connection to ground potential
- FL-PP-RJ45/RJ45-B with extended temperature range -40 °C ... 85 °C
- Multiple options for securing field cables:
  - Spring connection terminal blocks
  - Screw connection terminal blocks
  - LSA connection terminal blocks
  - RJ45-RJ45 transition
- ATEX approval for the following patch panels:
  - FL-PP-RJ45-SCC
  - FL-PP-RJ45-SC
  - FL-PP-RJ45/RJ45
- Shipbuilding approval according to DNV for the following patch panels:
  - FL-PP-RJ45-SCC
  - FL-PP-RJ45-SC
  - FL-PP-RJ45-LSA
  - FL-PP-RJ45/RJ45
  - FL CAT5 TERMINAL BOX



Make sure you always use the latest documentation. It can be downloaded at [phoenixcontact.net/products](http://phoenixcontact.net/products).



This data sheet is valid for all products listed on the following page:

## 2 Table of contents

1	Description.....	1
2	Table of contents .....	2
3	Ordering data.....	3
4	Technical data .....	6
5	Safety regulations and installation notes.....	7
5.1	Installation in zone 2 (only FL-PP-RJ45-SCC, FL-PP-RJ45-SC and FL-PP-RJ45/RJ45) .....	7
6	FL-PP-RJ45-SCC with spring connection terminal blocks .....	8
6.1	Structure.....	8
6.2	Dimensions .....	8
6.3	Connecting the Ethernet network .....	8
7	FL-PP-RJ45-SC with screw connection terminal blocks .....	9
7.1	Structure.....	9
7.2	Dimensions .....	9
7.3	Connecting the Ethernet network .....	9
8	FL-PP-RJ45-LSA with LSA connection terminal blocks .....	10
8.1	Structure.....	10
8.2	Dimensions .....	10
8.3	Connecting the Ethernet network .....	10
9	FL-PP-RJ45/RJ45 with RJ45 socket.....	11
9.1	Structure.....	11
9.2	Dimensions .....	11
9.3	Connecting the Ethernet network .....	11
10	FL-PP-RJ45/RJ45-B with RJ45 socket, slim overall width .....	12
10.1	Dimensions .....	12
10.2	Connecting the Ethernet network .....	12
11	FL CAT5 TERMINAL BOX with screw connection terminal blocks .....	13
11.1	Structure.....	13
11.2	Dimensions .....	13
11.3	Connecting the Ethernet network .....	13
12	Shield grounding selection.....	14
13	Circuit diagrams.....	14

### 3 Ordering data

#### Products

Description	Type	Order No.	Pcs./Pkt.
Patch panel, one RJ45 socket to 8 spring-cage connection terminal blocks (1:1 assignment), CAT5e, 10/100/1000 Mbps, DIN rail mounting, IP20, option of shield contacting on DIN rail via jumpers	FL-PP-RJ45-SCC	2901642	1
Patch panel, one RJ45 socket to 8 screw connection terminal blocks (1:1 assignment), CAT5e, 10/100/1000 Mbps, DIN rail mounting, IP20, option of shield contacting on DIN rail via jumpers	FL-PP-RJ45-SC	2901643	1
Patch panel, one RJ45 socket to 8 LSA connection terminal blocks (1:1 assignment), CAT5e, 10/100/1000 Mbps, DIN rail mounting, IP20, option of shield contacting on DIN rail via jumpers	FL-PP-RJ45-LSA	2901645	1
Patch panel, two RJ45 sockets (1:1 assignment), CAT5e, 10/100/1000 Mbps, DIN rail mounting, IP20, option of shield contacting on DIN rail via jumpers	FL-PP-RJ45/RJ45	2901646	1
Patch panel, slim overall width, extended temperature range, two RJ45 sockets, 1:1 assignment, consistent shield, CAT5, 10/100 Mbps, DIN rail mounting, IP20	FL-PP-RJ45/RJ45-B	2904933	1
Patch panel, one RJ45 socket to 4 screw connection terminal blocks (1, 2, 3, 6 assignment), CAT5, 10/100 Mbps, DIN rail mounting, IP20, option of shield contacting on DIN rail	FL CAT5 TERMINAL BOX	2744610	1

#### Accessories

Description	Type	Order No.	Pcs./Pkt.
<b>Network isolators</b>			
Passive network isolator for electrical isolation in Ethernet networks, protects Ethernet devices from potential differences up to 4 kV. Can be used for transmission speeds of up to 100 Mbps. Connection via RJ45 and COMBICON pluggable screw terminal block.	FL ISOLATOR 100-RJ/SC	2313928	1
Passive network isolator for electrical isolation in Ethernet networks, protects Ethernet devices from potential differences up to 4 kV. Can be used for transmission speeds of up to 100 Mbps. Connection for two RJ45 connectors possible.	FL ISOLATOR 100-RJ/RJ	2313931	1
Passive network isolator for electrical isolation in Ethernet networks, protects Ethernet devices from potential differences up to 4 kV. Can be used for transmission speeds of up to 1 Gbps. Connection for two RJ45 connectors possible.	FL ISOLATOR 1000-RJ/RJ	2313915	1
Passive network isolator for electrical isolation in Ethernet networks, protects Ethernet devices from potential differences up to 4 kV. Can be used for transmission speeds up to 100 Mbps. Ethernet connection via two M12 sockets (D-coded).	FL ISOLATOR 100-M12	2902985	1

**Accessories [...]**

Description	Type	Order No.	Pcs./Pkt.
Passive network isolator with pre-installed adapter for mounting on a DIN rail. Electrical isolation in Ethernet networks. For protection against potential differences up to 4 kV. Transmission speed of up to 100 Mbps. M12 socket (D-coded).	FL ISOLATOR 100-M12 RMS	2904671	1
<b>Patch cable, CAT5</b>			
Pre-assembled, 0.24 m	FL CAT5 PATCH 0.24	2700301	10
Pre-assembled, 0.3 m	FL CAT5 PATCH 0.3	2832250	10
Pre-assembled, 0.5 m	FL CAT5 PATCH 0.5	2832263	10
Pre-assembled, 1.0 m	FL CAT5 PATCH 1.0	2832276	10
Pre-assembled, 1.5 m	FL CAT5 PATCH 1.5	2832221	10
Pre-assembled, 2.0 m	FL CAT5 PATCH 2.0	2832289	10
Pre-assembled, 3.0 m	FL CAT5 PATCH 3.0	2832292	10
Pre-assembled, 5.0 m	FL CAT5 PATCH 5.0	2832580	10
Pre-assembled, 7.5 m	FL CAT5 PATCH 7.5	2832616	10
Pre-assembled, 10.0 m	FL CAT5 PATCH 10.0	2832629	10
<b>Patch cable, CAT6</b>			
Pre-assembled, 0.3 m	FL CAT6 PATCH 0.3	2891181	10
Pre-assembled, 0.5 m	FL CAT6 PATCH 0.5	2891288	10
Pre-assembled, 1.0 m	FL CAT6 PATCH 1.0	2891385	10
Pre-assembled, 1.5 m	FL CAT6 PATCH 1.5	2891482	10
Pre-assembled, 2.0 m	FL CAT6 PATCH 2.0	2891589	10
Pre-assembled, 3.0 m	FL CAT6 PATCH 3.0	2891686	10
Pre-assembled, 5.0 m	FL CAT6 PATCH 5.0	2891783	10
Pre-assembled, 7.5 m	FL CAT6 PATCH 7.5	2891880	10
Pre-assembled, 10 m	FL CAT6 PATCH 10	2891877	10
Pre-assembled, 12.5 m	FL CAT6 PATCH 12.5	2891369	5
Pre-assembled, 15.0 m	FL CAT6 PATCH 15.0	2891372	5
Pre-assembled, 20.0 m	FL CAT6 PATCH 20.0	2891576	5
<b>CAT5-SF/UTP cables</b>			
CAT5-SF/UTP cable (J-02YS(ST)C HP 2 x 2 x 24 AWG), heavy-duty installation cable 2 x 2 x 0.22 mm <sup>2</sup> , solid conductor, shielded, outer sheath: 7.8 mm diameter, inner sheath: 5.75 mm ± 0.15 mm diameter, (length in meters according to customer requirements)	FL CAT5 HEAVY	2744814	1
CAT5-SF/UTP cable (J-02YS(ST)C HP 2 x 2 x 24 AWG), heavy-duty installation cable 2 x 2 x 0.22 mm <sup>2</sup> , solid conductor, shielded, outer sheath: 7.8 mm diameter, inner sheath: 5.75 mm ± 0.15 mm diameter, pre-assembled on both sides with RJ45 connector, crossover or line (length in meters according to customer requirements)	FL CAT5 HEAVY CONF/	2744827	1
CAT5-SF/UTP cable (J-LI02YS(ST)C H 2 x 2 x 26 AWG), light-duty, flexible installation cable 2 x 2 x 0.14 mm <sup>2</sup> , fine strand, shielded, outer sheath: 5.75 mm ± 0.15 mm diameter (length in meters according to customer requirements)	FL CAT5 FLEX	2744830	1

Description	Type	Order No.	Pcs./Pkt.
<b>Tools</b>			
Crimping pliers, for assembling the RJ45 connectors FL PLUG RJ45... , for on-site assembly	FL CRIMPTOOL	2744869	1
Actuation tool, for ST terminal blocks, also suitable for use as a flat-bladed screwdriver, size: 0.4 x 2.5 x 75 mm, 2-component handle, with non-slip grip	SZF 0-0.4X2.5	1204504	1
Split-core tool for connecting cables to LSA-PLUS strips	CT-WZ/A	2765505	1
Stripping tool, for the multi-stage stripping of shielded cables	VS-CABLE-STRIP-VARIO	1657407	1

## 4 Technical data

Ethernet interface	FL-PP-RJ45-SCC	FL-PP-RJ45-SC	FL-PP-RJ45-LSA	FL-PP-RJ45/RJ45	FL-PP-RJ45/RJ45-B	FL CAT5 TERMINAL BOX
Connection	Spring connection	Screw connection	LSA	RJ45	RJ45	Screw connection
Cable diameter [mm]	6 ... 10	6 ... 10	6 ... 10	-	-	6 ... 10
Conductor cross section [mm <sup>2</sup> ]						
Solid	0.2 ... 1.5	0.14 ... 1.5	0.128...0.325	-	-	0.14 ... 1.5
Stranded	0.2 ... 1.0	0.14 ... 1.0	0.128...0.325	-	-	0.14 ... 1.0
AWG	24 ... 16	26 ... 16	26 ... 22	-	-	26 ... 16
Pin assignment	1:1	1:1	1:1	1:1	1:1	1, 2, 3, 6
Connection	RJ45 CAT5e				RJ45 CAT5	
Transmission rate	10/100/1000 Mbps				10/100 Mbps	
Transmission length	100 m (including patch cables)					
Cable impedance	100 Ω					
Insertion cycles	≤ 2500					
<b>General data</b>						
Degree of protection	IP20					
Weight	45 g	55 g	55 g	39 g	33 g	39 g
Dimensions (W/H/D) [mm]	29 x 90 x 53	29 x 90 x 53	29 x 90 x 53	29 x 90 x 53	22.5 x 78 x 44	25 x 90 x 52
Housing material	PVC/PA					
Current consumption	<1 A					
<b>Ambient conditions</b>						
Ambient temperature						
Operation		-25°C ... 70°C			-40°C ... 85°C	-25°C ... 70°C
Assembly		-10°C ... 70°C			-40°C ... 85°C	-10°C ... 70°C
Storage/transport		-25°C ... 85°C			-40°C ... 85°C	-25°C ... 85°C
Max. permitted humidity (operation)	25% ... 95% (non-condensing)					
Vibration resistance according to IEC 60068-2-6	5g, 150 Hz, 2.5 h, in XYZ direction					
Shock test according to IEC 60068-2-27	25g, 11 ms period, half-sine shock pulse					

## 5 Safety regulations and installation notes



### WARNING:

Observe the following safety notes when using the device.

- Installation, operation, and maintenance may only be carried out by qualified electricians. Follow the installation instructions as described. When installing and operating the device, the applicable regulations and safety directives (including national safety directives), as well as the general codes of practice, must be observed. The safety data is provided in the packing slip and on the certificates (conformity assessment, additional approvals where applicable).
- Access to circuits within the component is not permitted.
- The component is maintenance-free. Repairs may only be carried out by the manufacturer.

### 5.1 Installation in zone 2 (only FL-PP-RJ45-SCC, FL-PP-RJ45-SC and FL-PP-RJ45/RJ45)

The following components have ATEX approval:

Type	Order No.	ATEX approval
FL-PP-RJ45-SCC	2901642	⊕ II 3 G Ex nA IIC Gc U
FL-PP-RJ45-SC	2901643	
FL-PP-RJ45/RJ45	2901646	



### WARNING: Explosion hazard when used in potentially explosive areas

Make sure that the following notes and instructions are observed.

- Only devices which are designed for operation in Ex zone 2 and are suitable for the conditions at the installation location may be connected to the circuits in zone 2.
  - In potentially explosive areas, always disconnect the power before snapping the device onto the DIN rail or removing it from the DIN rail, or connecting or disconnecting the cables or the plug-in bridge.
  - To ensure safe operation, the RJ45 connector must have a fully functioning locking clip. Repair any damaged connectors immediately.
  - The component must be disabled and immediately removed from the potentially explosive area if it is damaged, was subjected to an impermissible load, stored incorrectly or if it malfunctions.
  - The DIN rail must be connected to protective ground.
  - Due to self-heating during operation, the Ethernet patch panels may be used with the current value given and at ambient temperatures of  $-25^{\circ}\text{C} \dots +70^{\circ}\text{C}$  at the installation location of equipment, primarily control cabinets, for temperature class T4. When using the components in equipment of temperature classes T3 through T1, ensure that the highest temperature on the components does not exceed the operating temperature range.
- The category 3 component is designed for installation in zone 2 potentially explosive areas. It meets the requirements of EN 60079-0:2012+A11:2013 and EN 60079-15:2010.
  - Observe the specified conditions for use in potentially explosive areas.
  - The component should be installed so that a degree of protection of at least IP54 is achieved in accordance with EN 60529. To this end, a suitable, approved housing that meets the requirements of EN 60079-15 should be used.

## 6 FL-PP-RJ45-SCC with spring connection terminal blocks

### 6.1 Structure

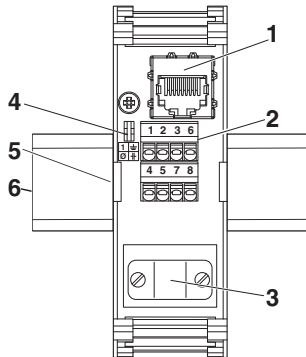

- 1 RJ45 socket (TP port)
- 2 Spring connection terminal blocks for field cabling
- 3 Strain relief with overall shielding braid
- 4 Plug-in bridge for selecting shield grounding
- 5 Universal snap-on foot for DIN rails
- 6 DIN rail

### 6.2 Dimensions

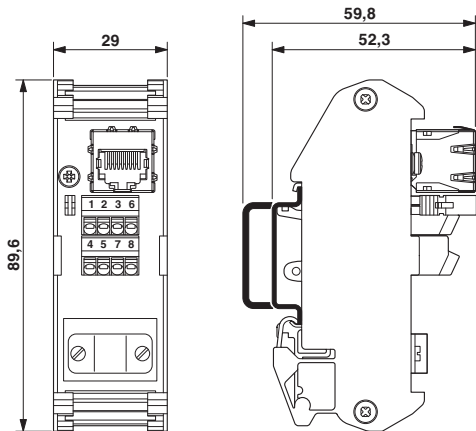

Figure 1 Dimensions FL-PP-RJ45-SCC

### 6.3 Connecting the Ethernet network

#### Twisted pair interface (TP port)



Only use shielded twisted pair cables and corresponding shielded RJ45 connectors.

- Take the Ethernet patch cable which leads to the end device and has a RJ45 connector, and push it into the RJ45 socket (TP port) until the connector audibly snaps in.

### Pin assignment and color coding

PROFINET		Ethernet	
		TIA 568 A	TIA 568 B
1 2 3 6		1 2 3 6 4 5 7 8	1 2 3 6 4 5 7 8
1 YE		1 WH/GN	1 WH/OG
2 OG		2 GN	2 OG
3 WH		3 WH/OG	3 WH/GN
6 BU		6 OG	6 GN
		4 BU	4 BU
		5 WH/BU	5 WH/BU
		7 WH/BN	7 WH/BN
		8 BN	8 BN

Figure 2 Ethernet (IEC 80.3u: TIA 568 A, TIA 568 B) and PROFINET

- YE = yellow
- OG = orange
- WH = white
- BU = blue
- GN = green
- BN = brown

### Spring connection terminal blocks

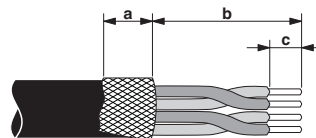

Figure 3 Required stripping lengths

- a = 10 mm
- b = 40 mm
- c = 8 mm

- Remove cable sheath in accordance with length b.
- Fold back 10 mm of the braided shield over the outer sheath.
- Remove the aluminum foil.
- Shorten wires 4, 5, 7, and 8 by 10 mm as required for the lower terminal block.
- Strip 8 mm off each single wire.
- Lay the shielding under the clip bracket of the strain relief and screw tight.
- Connect all single wires to the spring connection terminal blocks. If possible, make sure the single wires remain twisted up to the connection terminal blocks.



## 8 FL-PP-RJ45-LSA with LSA connection terminal blocks

### 8.1 Structure

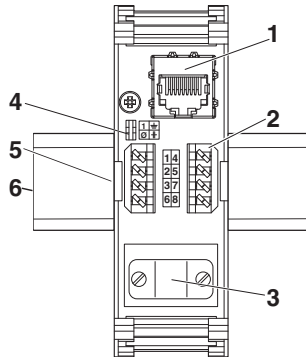

- 1 RJ45 socket (TP port)
- 2 LSA connection terminal blocks for field cabling
- 3 Strain relief with overall shielding braid
- 4 Plug-in bridge for selecting shield grounding
- 5 Universal snap-on foot for DIN rails
- 6 DIN rail

### 8.2 Dimensions

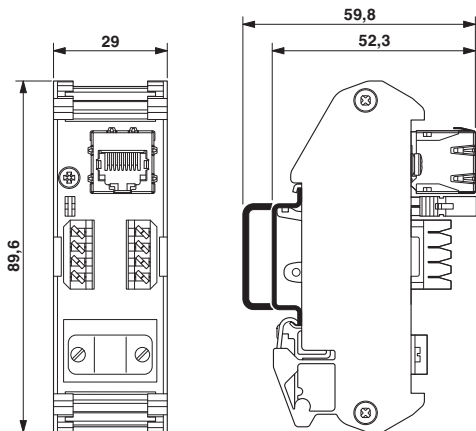

Figure 7 Dimensions FL-PP-RJ45-LSA

### 8.3 Connecting the Ethernet network

#### Twisted pair interface (TP port)



Only use shielded twisted pair cables and corresponding shielded RJ45 connectors.

- Take the Ethernet patch cable which leads to the end device and has a RJ45 connector, and push it into the RJ45 socket (TP port) until the connector audibly snaps in.

### Pin assignment and color coding

PROFINET		Ethernet																	
		TIA 568 A	TIA 568 B																
1	2	3	6	1	2	3	6	4	5	7	8	1	2	3	6	4	5	7	8
Yellow	Orange	White	Blue	Green	White	Orange	Blue	Brown	White	Green	Blue	Brown	White	Green	Blue	Brown			
1	2	3	6	1	2	3	6	4	5	7	8	1	2	3	6	4	5	7	8
YE	OG	WH	BU	WH/GN	GN	WH/OG	OG	BU	WH/BU	WH/BN	BN	WH/OG	OG	WH/GN	GN	BU	WH/BU	WH/BN	BN

Figure 8 Ethernet (IEC 80.3u: TIA 568 A, TIA 568 B) and PROFINET

- YE = yellow
- OG = orange
- WH = white
- BU = blue
- GN = green
- BN = brown

### LSA connection terminal blocks

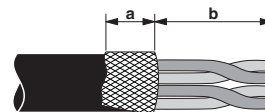
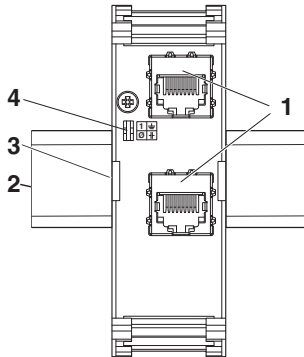

Figure 9 Required stripping lengths

- a = 10 mm
- b = 50 mm
- Remove cable sheath in accordance with length b.
- Fold back 10 mm of the braided shield over the outer sheath.
- Remove the aluminum foil.
- Lay the shielding under the clip bracket of the strain relief and screw tight.
- Connect the wire pairs to the LSA connection strips using the LSA split-core tool. If possible, make sure the single wires remain twisted up to the terminal strips.
- Make sure that the wires are flush with the terminal strip.

## 9 FL-PP-RJ45/RJ45 with RJ45 socket

### 9.1 Structure



- 1 RJ45 socket (TP port)
- 2 DIN rail
- 3 Universal snap-on foot for DIN rails
- 4 Plug-in bridge for selecting shield grounding

### 9.2 Dimensions

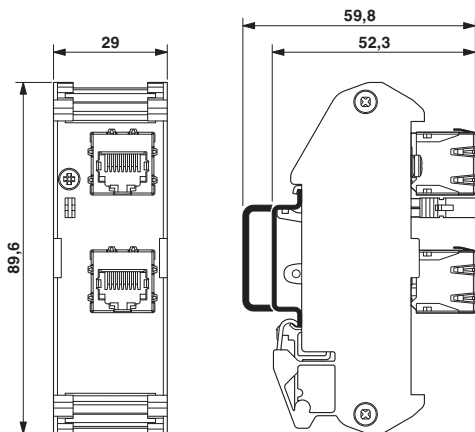

Figure 10 Dimensions FL-PP-RJ45/RJ45

### 9.3 Connecting the Ethernet network

The device is equipped with two RJ45 Ethernet interfaces for connection of twisted-pair cables.



Only use shielded twisted pair cables and corresponding shielded RJ45 connectors.

- Take the Ethernet patch cable which leads to the end device and has a RJ45 connector, and push this into the RJ45 socket (TP port) until the connector audibly snaps in.
- Push the field cable with the RJ45 connector into the second RJ45 socket until the connector audibly snaps in.



In regard to the correct function of the device, it is not important which port is assigned for incoming and outgoing cables.

## 10 FL-PP-RJ45/RJ45-B with RJ45 socket, slim overall width

### 10.1 Dimensions

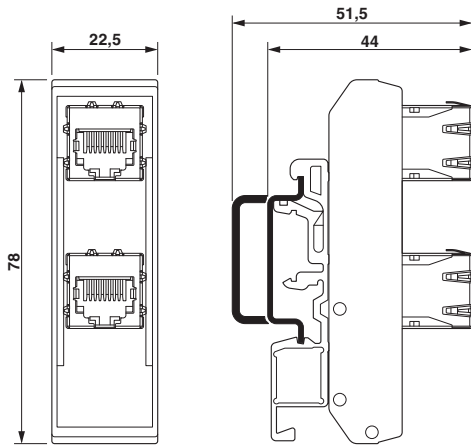

Figure 11 Dimensions FL-PP-RJ45/RJ45-B

### 10.2 Connecting the Ethernet network

The device is equipped with two RJ45 Ethernet interfaces for connection of twisted-pair cables.



Only use shielded twisted pair cables and corresponding shielded RJ45 connectors.

- Take the Ethernet patch cable which leads to the end device and has a RJ45 connector, and push this into the RJ45 socket (TP port) until the connector audibly snaps in.
- Push the field cable with the RJ45 connector into the second RJ45 socket until the connector audibly snaps in.



In regard to the correct function of the device, it is not important which port is assigned for incoming and outgoing cables.

## 11 FL CAT5 TERMINAL BOX with screw connection terminal blocks

### 11.1 Structure

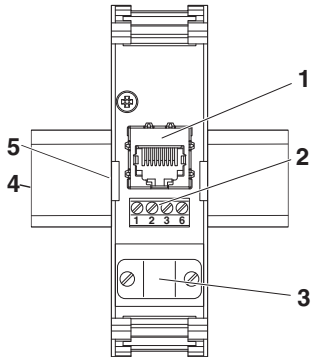

- 1 RJ45 socket (TP port)
- 2 Screw connection terminal blocks
- 3 Strain relief with overall shielding braid
- 4 DIN rail
- 5 Universal snap-on foot for DIN rails

### 11.2 Dimensions

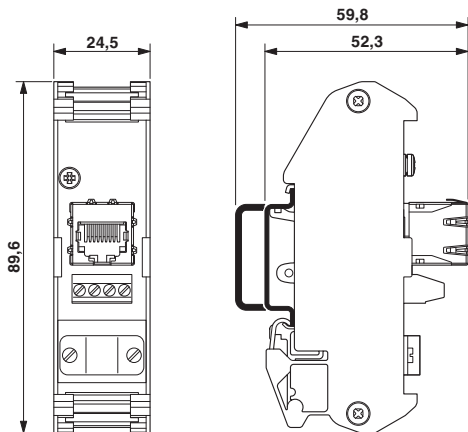

Figure 12 Dimensions FL CAT5 TERMINAL BOX

### 11.3 Connecting the Ethernet network

#### Twisted pair interface (TP port)



Only use shielded twisted pair cables and corresponding shielded RJ45 connectors.

- Take the Ethernet patch cable which leads to the end device and has a RJ45 connector, and push it into the RJ45 socket (TP port) until the connector audibly snaps in.

### Pin assignment and color coding

PROFINET		Ethernet	
1 2 3 6	TIA 568 A	TIA 568 B	1 2 3 6
1 YE	1 WH/GN	1 WH/OG	
2 OG	2 GN	2 OG	
3 WH	3 WH/OG	3 WH/GN	
6 BU	6 OG	6 GN	

Figure 13 Ethernet (IEC 80.3u: TIA 568 A, TIA 568 B) and PROFINET

- YE = yellow
- OG = orange
- WH = white
- BU = blue
- GN = green

### Screw connection terminal blocks

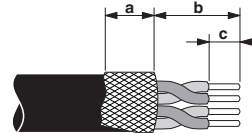

Figure 14 Required stripping lengths

- a = 10 mm
  - b = 10 mm
  - c = 5 mm
- Remove cable sheath in accordance with length b.
  - Fold back 10 mm of the braided shield over the outer sheath.
  - Remove the aluminum foil.
  - Strip off each individual wire to 5 mm.
  - Lay the shielding under the clip bracket of the strain relief and screw tight.
  - Connect the single wires to the screw terminal blocks. If possible, make sure the single wires remain twisted up to the connection terminal blocks.

## 12 Shield grounding selection

For the following patch panels, you can select the type of shielding with a plug-in bridge:

- FL-PP-RJ45-SCC
- FL-PP-RJ45-SC
- FL-PP-RJ45-LSA
- FL-PP-RJ45/RJ45

The patch panels come with the plug-in bridge inserted. The shielding is positioned directly on the ground potential (PE). With this arrangement, there is a low-ohmic electrical connection between the shield and the ground potential.

If you remove the plug-in bridge, the shield is connected to the ground potential via an RC combination. A high-ohmic resistance parallel to a capacitor ensures that high-frequency disturbances are delivered effectively to the ground potential without the presence of a low-ohmic electrical connection.

A single-sided grounding of the shield between two patch panels is best suited for suppressing electrical fields and ground loops.

### Overall shielding braid direct to PE (default setting)

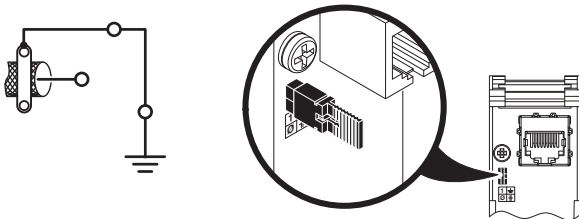

### Overall shielding braid to PE via RC element

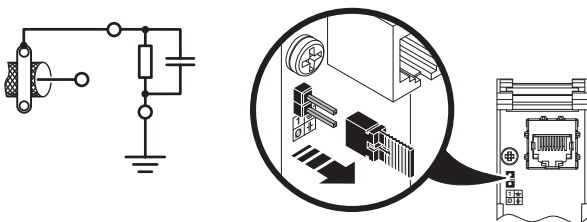

With FL-PP-RJ45/RJ45-B, the shielding is **not** connected with the DIN rail.  
 With FL CAT5 TERMINAL BOX, the shielding is always connected to the DIN rail via the universal snap-on foot.

## 13 Circuit diagrams

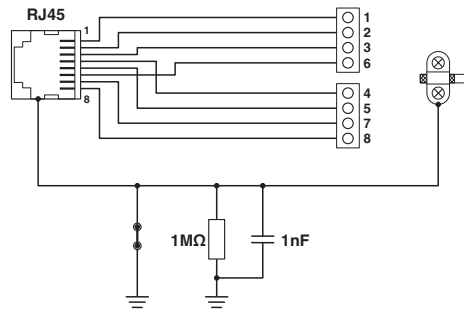

Figure 15 FL-PP-RJ45-SCC (2901642)  
 FL-PP-RJ45-SC (2901643)  
 FL-PP-RJ45-LSA (2901645)

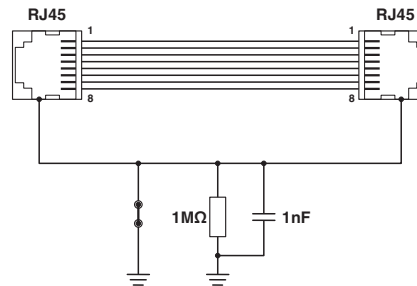

Figure 16 FL-PP-RJ45/RJ45 (2901646)

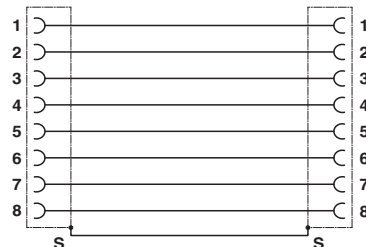

Figure 17 FL-PP-RJ45/RJ45-B (2904933)

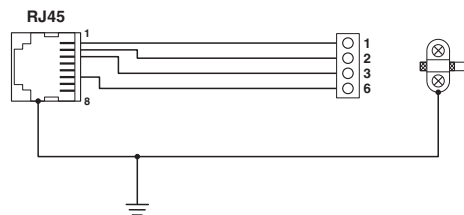

Figure 18 FL CAT5 TERMINAL BOX (2744610)



# SCATTERGOOD & JOHNSON LTD

ELECTRICAL ENGINEERING & FLUID CONTROL DISTRIBUTORS

Est.1899

At Scattergood & Johnson Ltd, we pride ourselves on being a technical distributor to specialist industries.

Working with a range of quality product suppliers across a number of specialist markets, we are not your average 'box shifter' - we are your technical and supply chain partner.

We fully support every product we sell - for free! Our internal team and external sales engineers can answer any product or application question, no matter the complexity.

Backing up this technical ability is a range of 50,000+ products available from stock for nationwide next day delivery (same day if required!), or you can collect what you need from any of our trade counters around the UK.

Select your specialist interest below to learn more about how we can help.



Online, In Branch and On the Road - Scattergood & Johnson Ltd, there when you need us.

# [www.scatts.co.uk](http://www.scatts.co.uk)