

Innovation in soft start technology



VMX-agility™

REMOTE KEYPAD USER GUIDE

MAN-AGY-016. Version 01



Remote Keypad User Guide

© **Motortronics UK Ltd**
Bristow House
Gillard Way, Ivybridge
PL21 9GG
UK
www.motortronics-uk.co.uk

[Full User Manual (MAN-AGY-015) available from www.motortronics-uk.co.uk]

© 2019 by Motortronics UK, all rights reserved

Copyright subsists in all Motortronics UK deliverables including magnetic, optical and/or any other soft copy of these deliverables. This document may not be reproduced, in full or in part, without written permission. Enquiries about copyright of Motortronics UK deliverables should be made to Motortronics UK Ltd. If, by permission of the copyright owner, any part of this document is quoted, then a statement specifying the original document shall be added to the quotation. Any such quotation shall be according to the original (text, figure or table) and may not be shortened or modified.

Connection and Operation

The remote keypad (VMX-AGY-012) can be used to control, monitor and program up to 32 VMX-agility™ soft starters.

The unit is powered from the host VMX-agility™ and requires an Ethernet cable for communication (Modbus RTU).

 As the remote keypad acts as the Modbus master, no additional master units must be placed within the network. Failure to observe this may lead to erratic behaviour, network failure and/or equipment damage.



Network Connection

For a configuration where there is only one VMX-agility™ unit (one-to-one), the remote and main unit can be directly cabled. See Diagram below:

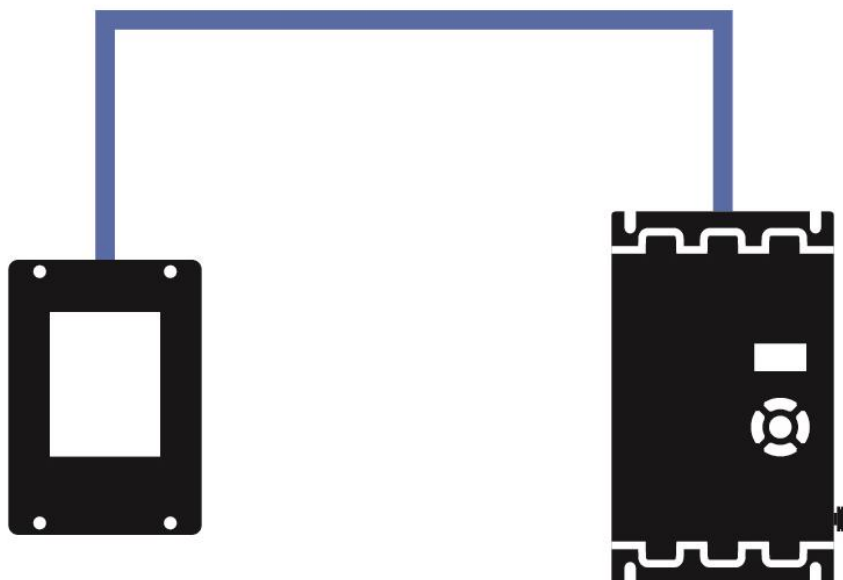

 Keypad power must be enabled on the VMX-agility™ starter (see below)

Enabling Keypad Power: Scroll to DEVICE menu → KEYPAD menu → KEYPAD PWR = ON

Connection and Operation (continued)

For multiple base units connected to the keypad, the use of VMX-SGY-011, CBL-036 and CBL-035 (terminator) is highly recommended. See diagram below.

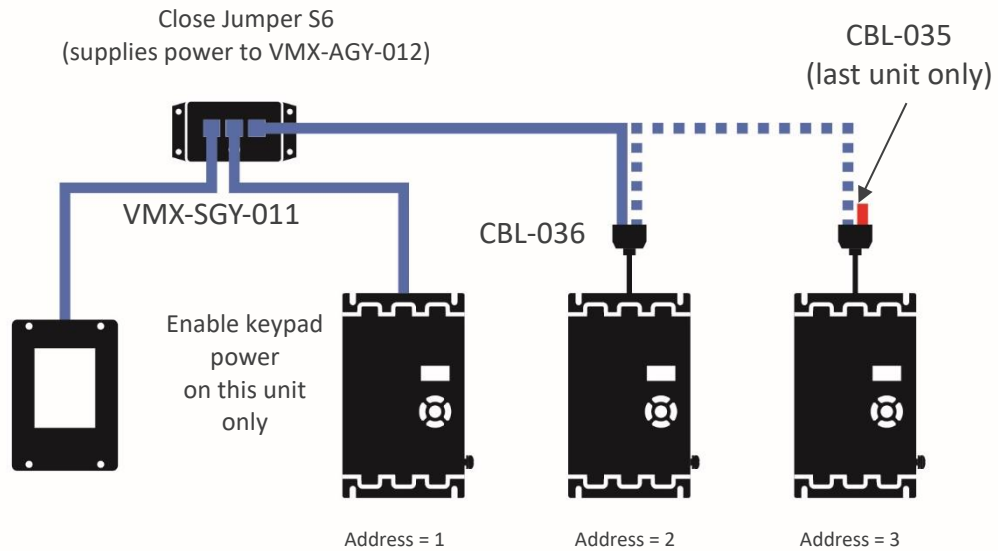

The VMX-agility™ units must have: a unique Modbus address on each unit and identical Parity/Baud rate values on each unit

Operation

Once connected to the VMX-agility™ host unit/s, menu structures and programming are the same as detailed in the VMX-agility™ manuals MAN-AGY-015 and MAN-AGY-014 (both may be downloaded from www.motortronics-uk.co.uk).

However, specific steps must be taken to connect the Remote Keypad to one or more VMX-agility™ host units.

Initial Power-Up

If the host VMX-agility™ unit/s and the remote keypad have the default Modbus transmission parameters set, and the host unit is powered and has Keypad power set to 'on', the keypad will automatically communicate with the host. The following status screen will be seen:

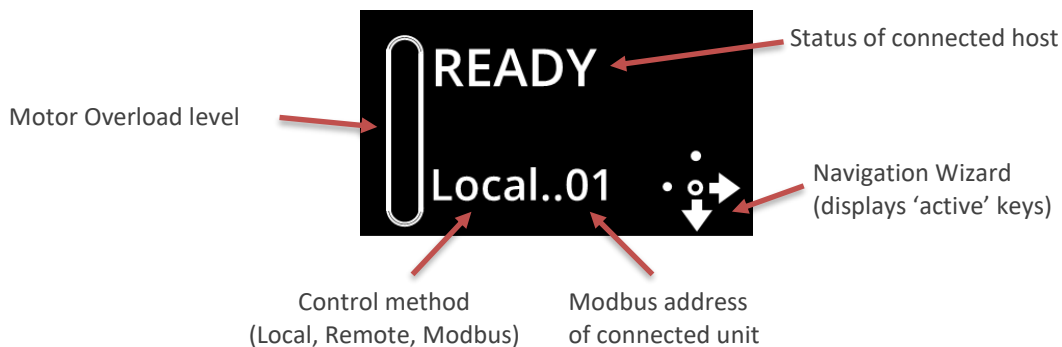

Connection and Operation (continued)

If any of the Modbus communication parameters are dissimilar on the host unit or remote keypad, communication will not be established. The keypad will display the following screen:



May show: Local, Remote or Modbus

By pressing the Right key, the user will be taken directly to the Modbus address selection menu:



If the selected Modbus address is valid, the status screen is displayed:

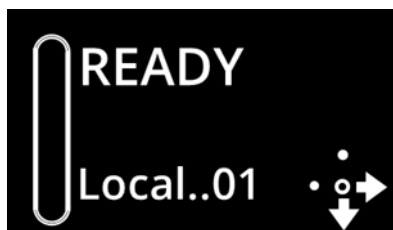

Selecting Units to Monitor/Configure

When the Remote Keypad is attached to multiple VMX-agility™ units on the Modbus network, the user can switch between each unit by using the following method.



To simplify this selection process, it is recommended that the host VMX-agility™ units are configured with consecutive Modbus addresses.

(continued over)

Connection and Operation (continued)

Procedure:

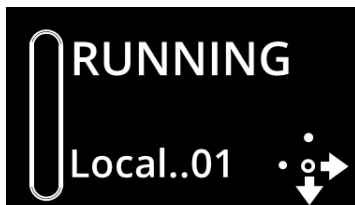

Modbus address
of connected unit

1. Press the 'Right' key
2. Address selection screen will be shown



3. Press the 'Centre' key. Display will change mode

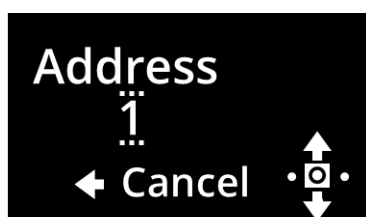

4. Use 'Up' or 'Down' keys to change address to the desired number (VMX-agility™ address). Press the 'Centre' key to confirm
5. Remote display will return to the Status screen and display the new address

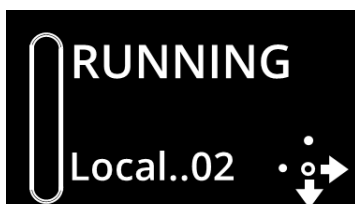

Installation

Mounting

Fix the unit to a flat, vertical surface using the mounting holes in the keypad enclosure.

- The orientation of the unit has the 'TOP' uppermost
- The location allows adequate front access
- The screen can be viewed

Do not install other equipment that generates significant heat close to the keypad.

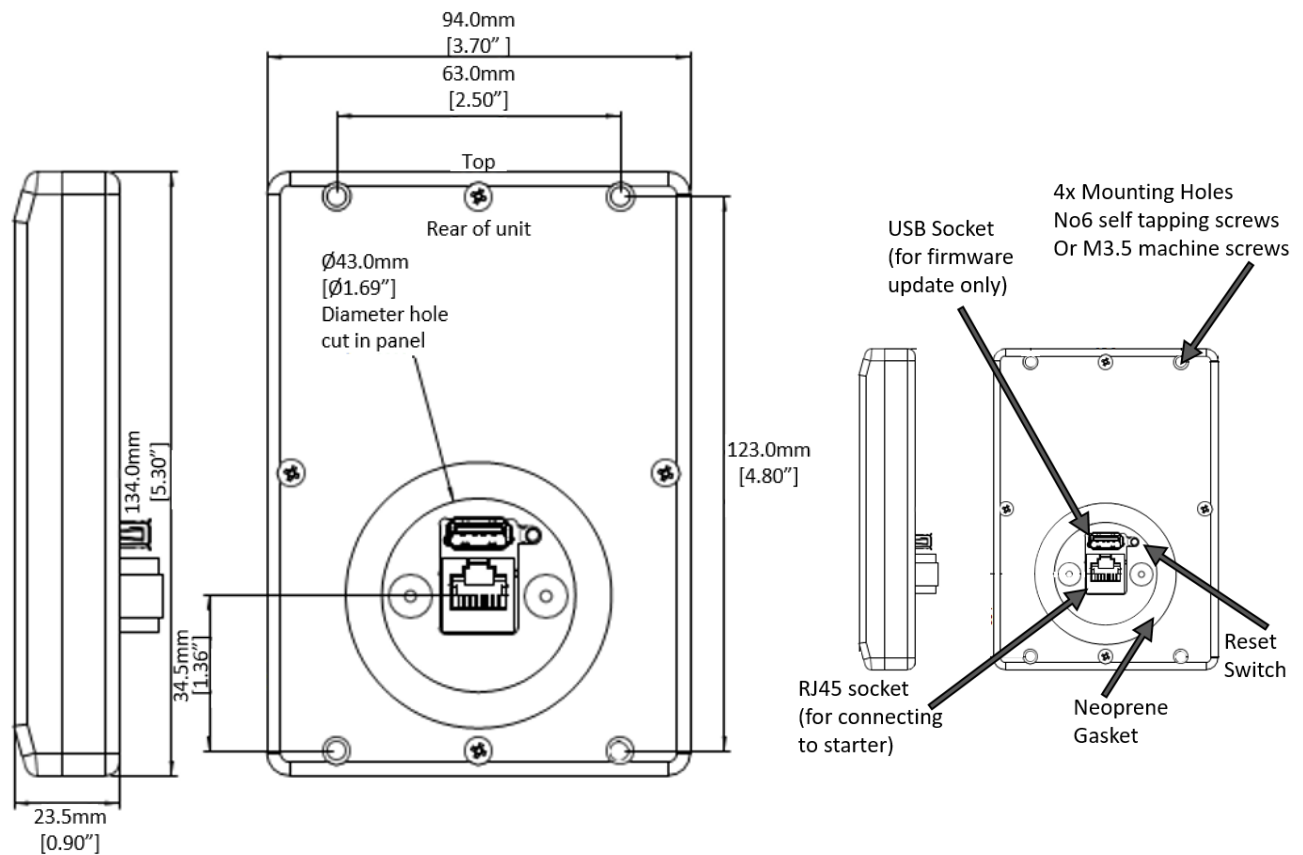

Firmware Update

1. Download the latest firmware version from www.motortronics-uk.co.uk and copy the files to a USB flash drive
2. Power down the Remote Keypad and insert the USB flash
3. Power-up the remote Keypad, the update will start automatically
4. When the update is complete (status screen shown), recycle the Remote Keypad power



Note: The host units and Keypad must have the same firmware version.



SCATTERGOOD & JOHNSON LTD

ELECTRICAL ENGINEERING & FLUID CONTROL DISTRIBUTORS

Est.1899

At Scattergood & Johnson Ltd, we pride ourselves on being a technical distributor to specialist industries.

Working with a range of quality product suppliers across a number of specialist markets, we are not your average 'box shifter' - we are your technical and supply chain partner.

We fully support every product we sell - for free! Our internal team and external sales engineers can answer any product or application question, no matter the complexity.

Backing up this technical ability is a range of 50,000+ products available from stock for nationwide next day delivery (same day if required!), or you can collect what you need from any of our trade counters around the UK.

Select your specialist interest below to learn more about how we can help.



Online, In Branch and On the Road - Scattergood & Johnson Ltd, there when you need us.

www.scatts.co.uk