



Innovation in soft starter technology



VMX-agility™

USER MANUAL

MAN-AGY-015. Version 02

VMX-agility™ user manual

© **Motortronics UK Ltd**
Bristow House
Gillard Way, Ivybridge
PL21 9GG
UK
www.motortronics-uk.co.uk

© 2019 by Motortronics UK, all rights reserved

Copyright subsists in all Motortronics UK deliverables including magnetic, optical and/or any other soft copy of these deliverables. This document may not be reproduced, in full or in part, without written permission. Enquiries about copyright of Motortronics UK deliverables should be made to Motortronics UK Ltd. If, by permission of the copyright owner, any part of this document is quoted, then a statement specifying the original document shall be added to the quotation. Any such quotation shall be according to the original (text, figure or table) and may not be shortened or modified.

Contents

Safety	5
Installation	6
Mounting	6
Requirements for an Enclosure	6
Enclosure Ventilation	6
Altitude Derate	6
Handling	7
Accessories	7
Dimensions VMX-AGY-101 to VMX-AGY-113	8
Dimensions VMX-AGY-201 to VMX-AGY-209	9
Dimensions VMX-AGY-301 to VMX-AGY-305	10
Environmental Specifications	11
Horizontal Mounting	11
Electrical Installation	12
Warnings	12
Electrical Supplies	12
Electromagnetic Compatibility	18
Motor Overload Protection	20
Electrical Connections	21
Main Circuit Wiring Diagram	21
Single Phase Operation	22
Control Terminal Connection	23
Control Terminal Functions	23
Digital Input 2 (D2) Selectable Functions	23
Digital Outputs Selectable Functions (13/14 and 21/22)	23
3-Wire Control Circuit Wiring Diagram	24
2-Wire Control Wiring Diagram	24
Display and Controls	25
Auto Setup Procedure (Auto App)	27
Setup by Individual Parameter Settings (Advanced)	27
Auto Application Setup Parameter Settings	27
Menu Structure	28
Function Descriptions	34
Trip and Fault Codes	43
Auto Reset Function	46
Auto Reset Assignable Trips	47

Auto Reset Function Descriptions	48
Communication	62
Modbus RTU Serial Communications	62
Modbus RTU Communications Interface.....	62
Modbus RTU Connections.....	62
Modbus Communications Configuration	63
Transmission Modes	63
Message Structure For RTU Mode	63
Address	63
Function Code	63
Data Field.....	63
CRC.....	64
Supported Functions	64
Write Multiple Registers.....	65
Modbus RTU Parameters	66
Memory Map.....	66
Message Timing	66
Special Modbus Registers	121
Modbus PNU Alphabetical Cross Reference	127
Updating Firmware	129
Update Procedure.....	129
Instruction for Updating	129
Applications.....	132
Motor Suitability and Associated Considerations	132
Maximum Motor Cable Length	133
Power Factor Correction Capacitors.....	133
Lightly Loaded, Small Motors.....	133
Motors Fitted with Integral Brakes	133
Older Motors	133
Wound-rotor or Slip-ring Motors	133
Enclosures	133
EU Compliance with the EMC Directive.....	134
Fuses.....	134
Rules for Specific Applications	134
High Inertia Loads	134
Frequent Starting.....	134
Soft-Stopping.....	134
Reversing Configuration	135

Replacement of Fluid Couplings.....	135
Two-speed Motor Applications.....	135
Overhauling Loads	135
Application Table.....	135
Concepts and principles of fixed-speed induction motor starting and control	137
Introduction.....	137
The Induction Motor.....	137
Starting Induction Motors.....	140
Electro-Mechanical Methods Of Starting	141
The Semiconductor Motor Controller	142
Running Induction Motors	143
Reliability Considerations	144
Accessory Installation	146
Power Supply VMX-AGY-020 and VMX-AGY-021	146
Connections.....	147
Control Terminal.....	147
Functions	147
3-Wire Control Using VMX-AGY-020/021	148
2-Wire Control Using VMX-AGY-020/021	148
Fan (VMX-AGY-030)	149
Fan (VMX-AGY-031)	150
Fitting	150
Remote Keypad (VMX-AGY-010).....	151
Network Connection.....	151
Keypad Connection and Operation	152
Operation	152
Initial Power-Up.....	152
Selecting Units To Monitor/Configure	153
Keypad Installation	155
Mounting.....	155
Sizing Guide	156
Key to Part Numbers.....	157
Notes.....	157

Safety

Important information

Installers should read and understand the instructions in this guide prior to installing, operating and maintaining the soft starter. The following symbols may appear in this guide or on the soft starter to warn of potential hazards or to draw attention to certain information.



Dangerous Voltage

Indicates the presence of a hazardous voltage which could result in personal injury or death.



Warning/Caution

Indicates a potential hazard. Any instructions that follow this symbol should be obeyed to avoid possible damage to the equipment, and personal injury or death.



Protective Earth (Ground)

Indicates a terminal which is intended for connection to an external conductor for protection against electric shock in case of a fault.

Caution Statements

The examples and diagrams in this manual are included solely for illustrative purposes. The information contained in this manual is subject to change at any time and without prior notice. In no event will responsibility or liability be accepted for direct, indirect or consequential damages resulting from the use or application of this equipment.

<p>VMX-agility™ soft starters contain dangerous voltages when connected to the mains supply. Only qualified personnel that have been completely trained and authorised, should carry out installation, operation and maintenance of this equipment.</p>
<p>Installation of the soft starter must be made in accordance with existing local and national electrical codes and regulations and have a minimum protection rating.</p>
<p>It is the responsibility of the installer to provide suitable grounding and branch circuit protection in accordance with local electrical safety codes.</p>
<p>This soft starter contains no serviceable or re-usable parts.</p>

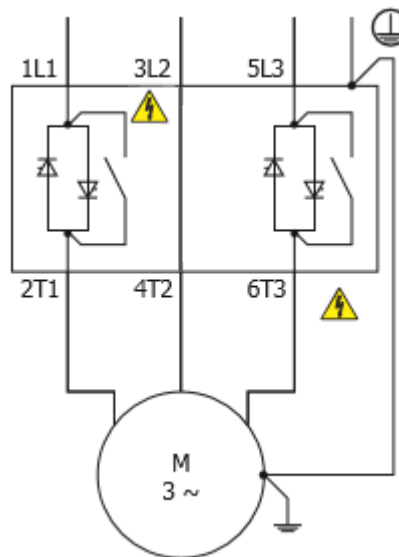

Installation

Mounting

Fix the unit to a flat, vertical surface using the mounting holes (or slots) on its base-plate. The mechanical outline diagrams, shown on Page 8, give the dimensions and mounting hole positions for each model. Ensure that:

- The orientation of the unit has the 'TOP' uppermost (unless horizontally mounted – see page 9).
- The location allows adequate front access.
- The screen can be viewed.

Do not install other equipment that generates significant heat close to the soft starter.

Requirements for an Enclosure

For a typical industrial environment, an enclosure would provide the following:

- A single location for the unit and its protection/isolation switch-gear
- The safe termination of cabling and/or bus-bars
- Means to effect proper air flow through the enclosure



Enclosure Ventilation

When fitting VMX-agility™ into a cabinet, ventilation must be provided if the heat output of the unit is greater than the cabinet will dissipate. The heat dissipated can be approximated with the formula:

Starting

Watts (VMX-agility™) = start current(A) x start time(s) x number of starts per hour/1800

Running Watts (VMX-agility™) = 0.4 x running amps

Use the following formula to determine the fan requirement. An allowance has been incorporated into the formula so that the figure for Q is the air delivery in the fan suppliers' data.

$$Q = (4 \times W_t / (T_{max} - T_{amb}))$$

Q = volume of air (cubic metres per hour-m³/h)

W_t = Heat produced by the unit and all other heat sources within the enclosure (Watts) T_{max} = Maximum permissible temperature within the enclosure (40°C for a fully rated agility™)

T_{amb} = Temperature of the air entering the enclosure (°C) [to work in CFM, substitute °F for °C. Q is now in CFM]

Altitude Derate

Altitude above sea level 1000m (3281ft). Above 1000m de rate by 1% of agility™ le per 100m (328ft) to a maximum altitude of 2000m (6562ft).

Ambient Temperature Derate

-20°C (-4°F) to 40°C (104°F). Above 40°C de-rate linearly by 2% of agility™ le per °C to a maximum of 60°C (140°F).

Installation (continued)

Handling

The VMX-agility soft start range comprises 3 frame sizes, with various weights and dimensions. See pages 8-10 for further information.

Prior to installing the agility unit, the installer should carry-out a risk assessment. If considered appropriate, a suitable handling device should be used.

Do not lift the VMX-agility unit by attachment to the 3-phase terminal connections or busbars.

WARNING

HANDLING AND LIFTING HAZARD

Ensure the area below any equipment is clear of all personnel and property.

Failure to follow this practice may result in death, serious injury, or damage to equipment.

Accessories

The following accessories have been developed and tested for use with the agility range of soft starts:

VMX-AGY-010 Remote keypad for VMX-AGY-101 to VMX-AGY-305. Provides remote functionality for up to 32 soft starter units.

VMX-AGY-020 100Vac – 240Vac power supply. Provides mains voltage control power and digital control functionality. **For use with VMX-AGY-101 to VMX-AGY-113 only.**

VMX-AGY-021 100Vac – 240Vac power supply. Provides mains voltage control power and digital control functionality. **For use with VMX-AGY-101 to VMX-AGY-305.**

VMX-AGY-030 Cooling fan accessory for VMX-AGY-101 to VMX-AGY-113 only. Increases the number of starts per hour (see page 19).

VMX-AGY-031 Cooling fan accessory for VMX-AGY-201 to VMX-AGY-209 only. Increases the number of starts per hour (see page 19).

Installation (continued)

Dimensions VMX-AGY-101 to VMX-AGY-113

[] = inch

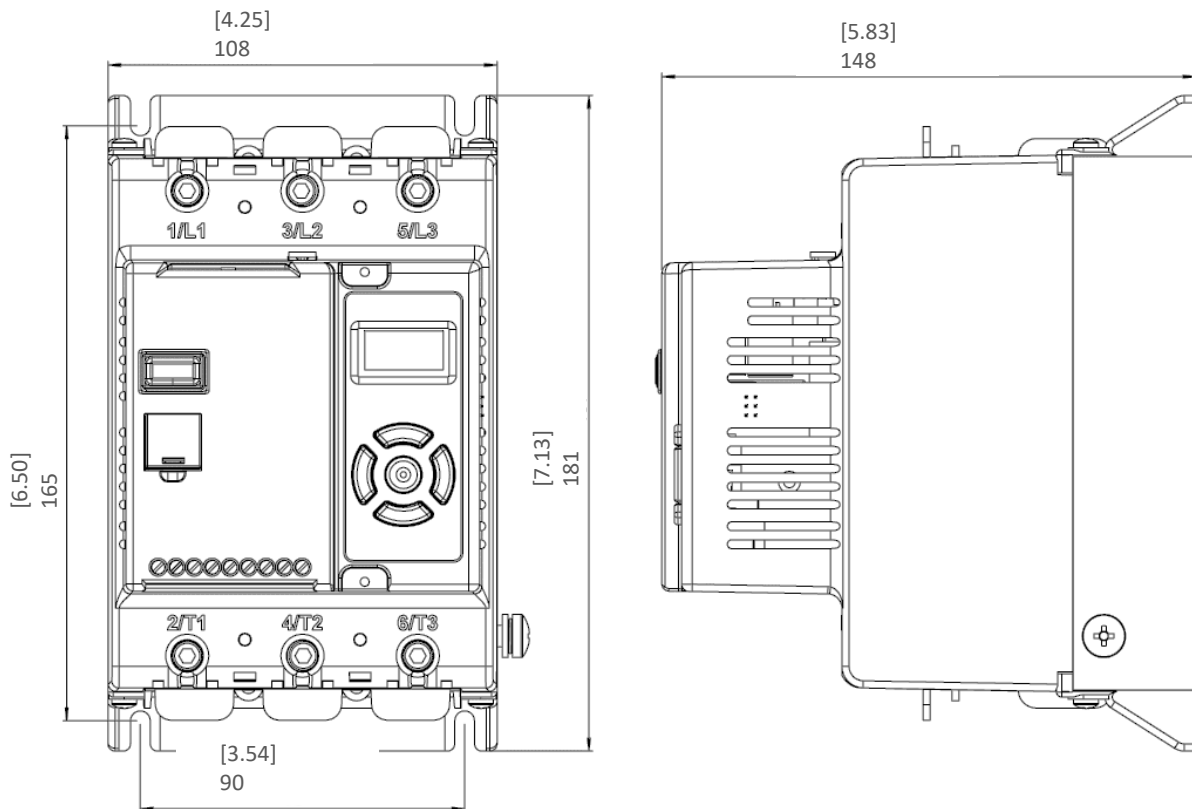

Weight 1.97kg (3.75lb)

Fitting

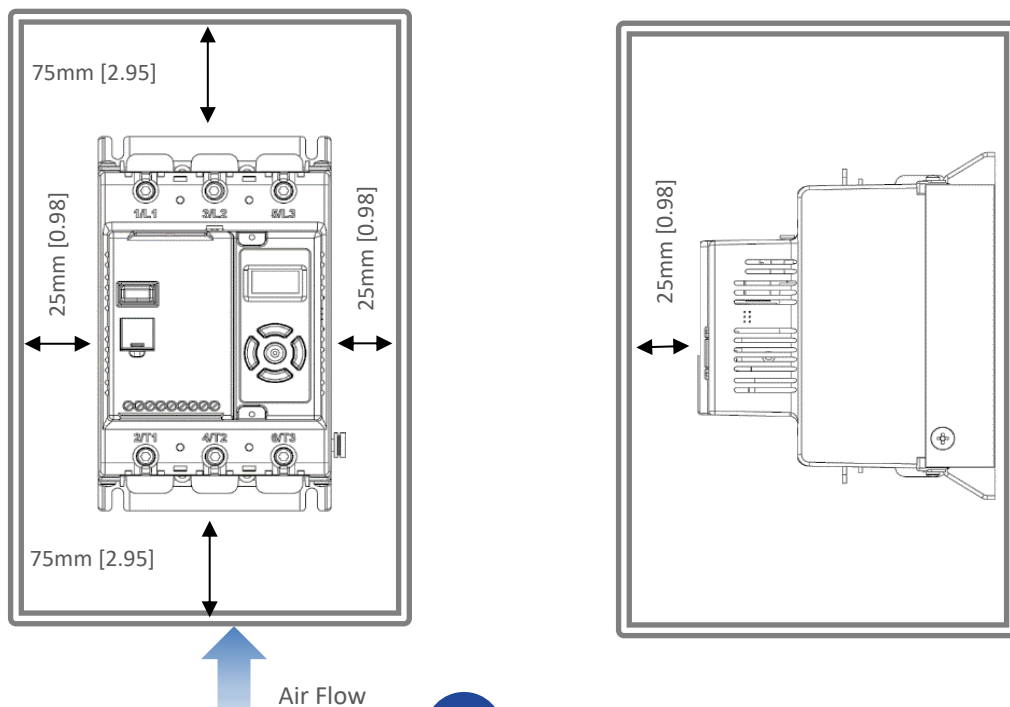

Installation (continued)

Dimensions VMX-AGY-201 to VMX-AGY-209

Weight 6 kg [13.22LB]

[] = inch

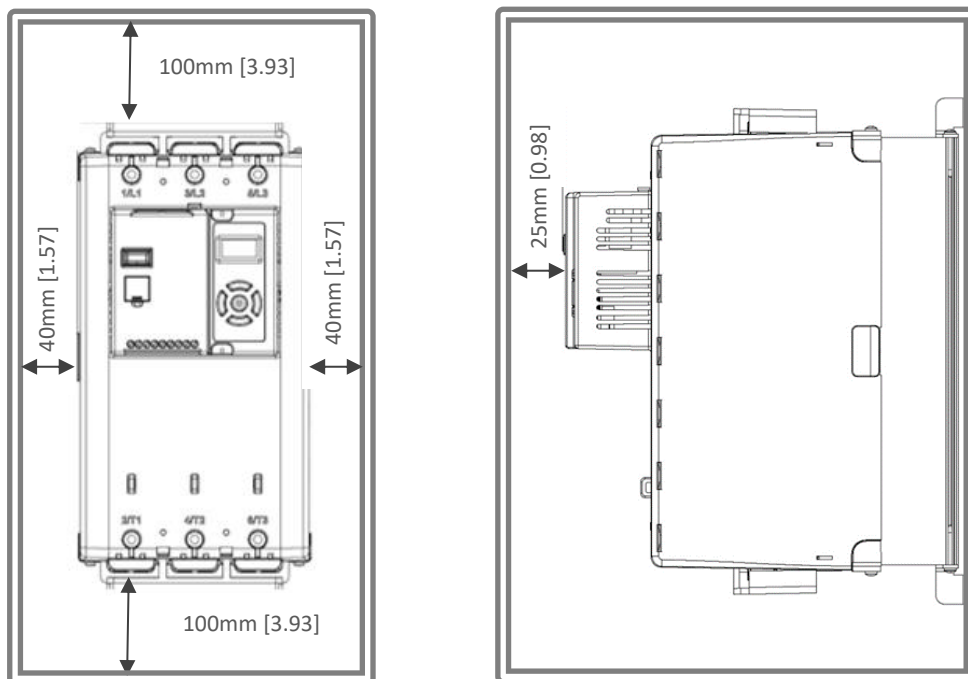
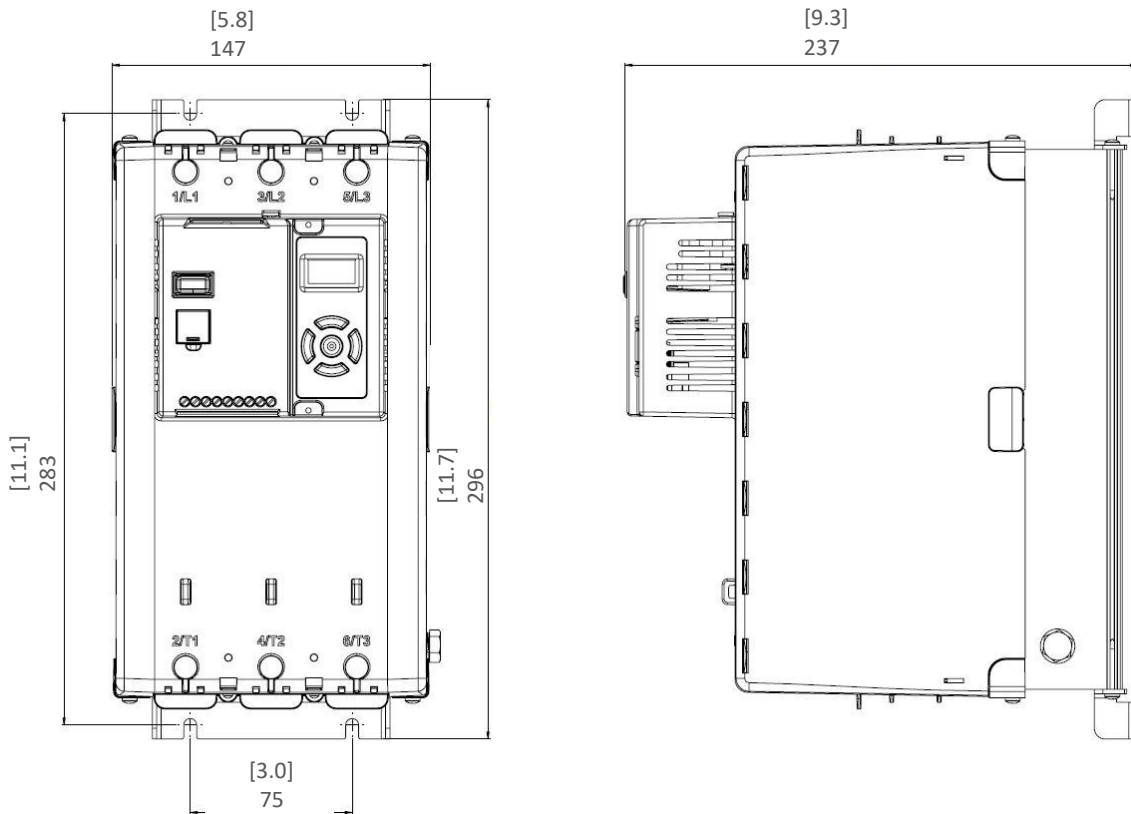

Installation (continued)

Dimensions VMX-AGY-301 to VMX-AGY-305

Weight 15kg [33.10lb]

[] = inch

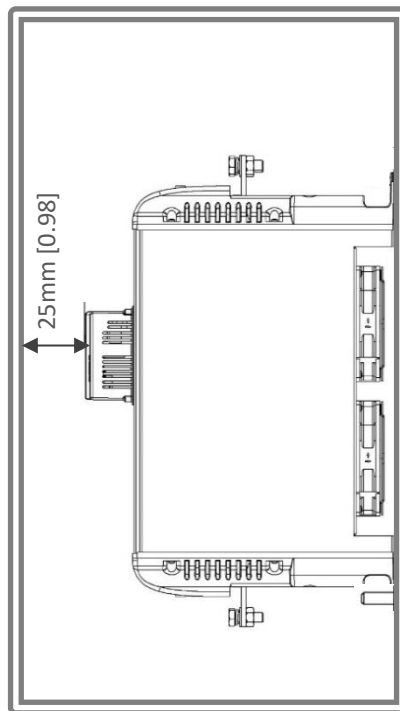
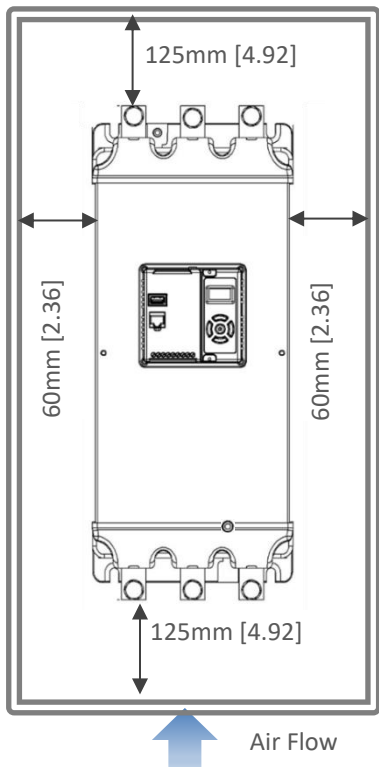
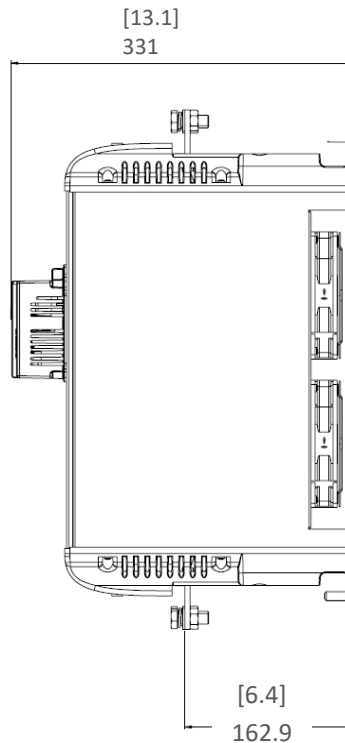
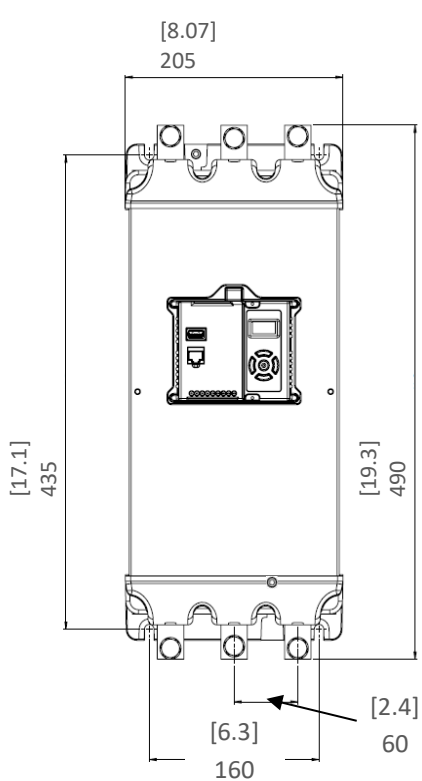

Installation (continued)

Environmental Specifications

Environmental Specifications							
Model (VMX-AGY-)	101	103	105	107	109	111	113
Frame Size	1						
Heat output (W)	9	12	14	16	20	25	30
Weight kg [lb]	1.97 [4.20]						
Model (VMX-AGY-)	201	203	205	207	209		
Frame Size	2						
Heat output (W)	37	49	61	74	90		
Weight kg [lb]	VMX-AGY-201-VMX-AGY-209 6.00 [13.22]						
Model (VMX-AGY-)	301	303	305				
Frame Size	3						
Heat output (W)	111	139	166				
Weight kg [lb]	15.00 [33.10]						
Ambient Operating Temperature	-20°C [-4°F] to 40°C [104°F] ; above 40°C derate linearly by 2% of VMX-agility Ie per °C to a maximum of 60°C (140°F)						
Transportation and Storage Temperature	-20°C to 70°C [-4°F to 158°F] continuous						
Humidity	max 85% non-condensing, not exceeding 50% @ 40°C [104°F]						
Maximum Altitude	1,000m [3281ft]; above 1000m derate by 1% of VMX-agility Ie per 100m (328ft) to a maximum altitude of 2,000m (6562ft)						
Environmental Rating	Main Circuit: IP00 (IP20 with optional finger guards); Control Circuit: IP20; No corrosive gases permitted						

Horizontal Mounting

The VMX-agility™ unit may be mounted horizontally if required. It will be necessary to apply a deration to the unit power in this instance – see Horizontal Rating Table (Page 16).

Electrical Installation

Warnings



Isolation

Caution: VMX-agility™ uses semiconductor devices in the main circuit and is not designed to provide isolation. For this reason isolation means must be installed in the supply circuit in accordance with the appropriate wiring and safety regulations.



Electrical Control Supply Requirements

All electrical connections are made to power input and output terminals, control terminals and an earth stud.



Fuse Protection

The Mains Supply and the Control Supply each require protection. Although all units have electronic overload protection for the Soft Starter, the installer should always fit fuses, for motor protection, between the unit and the Mains Supply, not between the unit and the motor. Semiconductor fuses can be supplied as an option for short-circuit protection of the semiconductors. These fuses must be fitted externally to the VMX-agility™ chassis to comply with certain standards. It is the responsibility of the installer and system designer/specifier to ensure that the required standards or regulations are not affected by so doing.



Safety

VMX-agility™ soft starters contain hazardous voltages when connected to the electrical power supply. Only qualified personnel who are trained and authorized should carry out installation, operation and maintenance of this equipment. Refer to and carefully follow all of the 'Warnings' section at the beginning of this user manual, as well as other warnings and notes throughout the manual.

Electrical Supplies

The unit requires a 3-phase balanced Mains Supply to provide the power for the controlled motor, and a 24Vdc for the internal control circuitry. The unit will not operate unless the control supply voltage is within the specified limits.

Electrical Installation (continued)

General Specification				
Product Standard		EN 60947-4-2: 2012		
Rated operational voltages		U_e	200Vac to 600Vac (See Key to part numbers)	
Rated operational current		I_e	See Rating Table	
Rating index		See Rating Table		
Rated frequencies		50 - 60Hz \pm 5Hz		
Rated duty		Uninterrupted		
Form designation		Form 1, Internally Bypassed		
Method of operation		Symmetrically controlled starter		
Method of control		Semi-automatic		
Method of connecting		Thyristors connected between motor windings and supply		
Number of poles		3 main poles, 2 main poles controlled by semiconductor switching element		
Rated insulation voltage		U_i	Main circuit	See Key to part numbers
			Control supply circuit	230Vac r.m.s ¹⁾
Rated impulse withstand voltage		U_{imp}	Main circuit	6 kV
			Control supply circuit	4 kV ¹⁾
IP code			Main circuit	IP00 (IP20 with finger guards ⁶⁾)
			Supply and Control circuit	IP20
Overvoltage Category / Pollution degree		III / 3		
Rated conditional short-circuit current and type of co-ordination with associated short circuit protective device (SCPD)		Type 1 co-ordination See Short Circuit Protection Tables for rated conditional short-circuit current and required current rating and characteristics of the associated SCPD		

Electrical Installation (continued)

General Specification (Continued)				
As Standard	Control Supply ⁽²⁾	Supply input	0, 24V	Protect with 4A UL listed fuse
		Kind of current, rated frequency	dc	
		Rated voltage U _s	24Vdc	
		Maximum power consumption	12VA (VMX-AGY-101 to VMX-AGY-113) 48VA (VMX-AGY-201 to VMX-AGY-305)	
	Control circuit ⁽²⁾	Programmable opto-isolated inputs	D1, D2	
		Common input, marking	COM	
		Kind of current, rated frequency	dc	
		Rated voltage U _c	24Vdc	
With VMX-AGY-020/ VMX-AGY-021 module	Control Supply	Supply input	L, N	
		Kind of current, rated frequency	ac, 50 - 60Hz ± 5Hz	
		Rated voltage U _s	110V to 230Vac	
		Rated input current	1A	
	Control circuit	Programmable opto-isolated inputs	D1, D2	
		Common input	COM	
		Kind of current, rated frequency	ac, 50 - 60Hz ± 5Hz	
		Rated voltage U _c	110V to 230Vac	
Auxiliary Circuit ⁽³⁾	Form A – Single gap make -contact (normally open)	13, 14		
	Form B – Single gap break-contact (normally closed)	21, 22		
	Utilisation category, voltage rating, current rating	Resistive load, 250Vac, 2A. Cosφ =0.5, 250Vac, 2A ⁽⁴⁾		

Continued over

Electrical Installation (continued)

General Specification (continued)

Electronic overload relay with manual reset and thermal memory	Trip Class	10 (factory default), 20 or 30 (selectable)
	Current setting	See Electronic Overload Relay Current Settings
	Rated frequency	50 to 60Hz ± 5Hz
	Time-current characteristics	See Fig.1 for trip curves (Trip time $T_p \pm 20\%$)
<p>¹⁾ With optional VMX-AGY-020 or VMX-AGY-021 power supply module. VMX-AGY-020 TO BE USED WITH VMX-AGY-101 TO VMX-AGY-113 ONLY</p> <p>²⁾ Must be supplied by class 2, limited voltage current or protected by a 4A UL 248 listed fuse</p> <p>³⁾ Compliant with Annex S of IEC 60947-1:2007 at 24Vdc</p> <p>⁴⁾ Not applicable for UL</p> <p>⁵⁾ The safety functions were not evaluated by UL. Listing is accomplished according to requirements of Standard UL 508 and CSA14-13, general use applications</p> <p>⁶⁾ For models VMX-AGY-101 to VMX-AGY-209 the main circuit IP20 rating only applies when the finger guards as supplied are fitted</p>		

Electrical Installation (continued)

Rating Table – Vertically Mounted												
I _e A ³⁾	kW ¹⁾			FLA A ³⁾	Hp ²⁾					Trip Class 10 I _e : AC-53a: 3.5-17: F-S ⁵⁾	Trip Class 20 I _e : AC-53a: 4-19: F-S ⁵⁾	Trip Class 30 I _e : AC-53a: 4-29: F-S ⁵⁾
	230V	400V	500V ⁴⁾		200V	208V	220-240V	440-480V	550-600V ⁴⁾			
17	4	7.5	7.5	17	3	5	5	10	15	-	-	VMX-AGY-101
17	4	7.5	7.5	17	3	5	5	10	15	-	VMX-AGY-101	VMX-AGY-103
17	4	7.5	7.5	17	3	5	5	10	15	VMX-AGY-101	VMX-AGY-103	VMX-AGY-105
22	5.5	11	11	22	5	5	7.5	15	20	VMX-AGY-103	VMX-AGY-105	VMX-AGY-107
29	7.5	15	15	27	7.5	7.5	7.5	20	25	VMX-AGY-105	VMX-AGY-107	VMX-AGY-109
35	7.5	18.5	22	34	10	10	10	25	30	VMX-AGY-107	VMX-AGY-109	VMX-AGY-111
41	11	22	22	41	10	10	10	30	40	VMX-AGY-109	VMX-AGY-111	VMX-AGY-113
55	15	30	37	52	15	15	15	40	50	VMX-AGY-111	VMX-AGY-113	VMX-AGY-201
66	18.5	37	45	65	20	20	20	50	60	VMX-AGY-113	VMX-AGY-201	VMX-AGY-203
80	22	45	55	77	20	25	25	60	75	VMX-AGY-201	VMX-AGY-203	VMX-AGY-205
106	30	55	75	100	30	30	30	75	100	VMX-AGY-203	VMX-AGY-205	VMX-AGY-207
132	37	75	90	125	40	40	40	100	125	VMX-AGY-205	VMX-AGY-207	VMX-AGY-209
160	45	90	110	156	50	50	60	125	150	VMX-AGY-207	VMX-AGY-209	VMX-AGY-301
195	55	110	132	192	60	60	60	150	200	VMX-AGY-209	VMX-AGY-301	VMX-AGY-303
242	75	132	160	242	75	75	75	200	250	VMX-AGY-301	VMX-AGY-303	VMX-AGY-305
302	90	160	200	302	100	100	100	250	300	VMX-AGY-303	VMX-AGY-305	-
361	110	200	250	361	125	125	150	300	350	VMX-AGY-305	-	-

Rating Table – Horizontally Mounted												
I _e A ³⁾	kW ¹⁾			FLA A ³⁾	Hp ²⁾					Trip Class 10 I _e : AC-53a: 3.5-17: F-S ⁵⁾	Trip Class 20 I _e : AC-53a: 4-19: F-S ⁵⁾	Trip Class 30 I _e : AC-53a: 4-29: F-S ⁵⁾
	230V	400V	500V ⁴⁾		200V	208V	220-240V	440-480V	550-600V ⁴⁾			
17	4	7.5	7.5	17	3	5	5	10	15	-	VMX-AGY-101	VMX-AGY-103
17	4	7.5	7.5	17	3	5	5	10	15	VMX-AGY-101	VMX-AGY-103	VMX-AGY-105
17	4	7.5	7.5	17	3	5	5	10	15	VMX-AGY-103	VMX-AGY-105	VMX-AGY-107
22	5.5	11	11	22	5	5	7.5	15	20	VMX-AGY-105	VMX-AGY-107	VMX-AGY-109
29	7.5	15	15	27	7.5	7.5	7.5	20	25	VMX-AGY-107	VMX-AGY-109	VMX-AGY-111
35	7.5	18.5	22	34	10	10	10	25	30	VMX-AGY-109	VMX-AGY-111	VMX-AGY-113
41	11	22	22	41	10	10	10	30	40	VMX-AGY-111	VMX-AGY-113	VMX-AGY-201
55	15	30	37	52	15	15	15	40	50	VMX-AGY-113	VMX-AGY-201	VMX-AGY-203
66	18.5	37	45	65	20	20	20	50	60	VMX-AGY-201	VMX-AGY-203	VMX-AGY-205
80	22	45	55	77	20	25	25	60	75	VMX-AGY-203	VMX-AGY-205	VMX-AGY-207
106	30	55	75	100	30	30	30	75	100	VMX-AGY-205	VMX-AGY-207	VMX-AGY-209
132	37	75	90	125	40	40	40	100	125	VMX-AGY-207	VMX-AGY-209	VMX-AGY-301
160	45	90	110	156	50	50	60	125	150	VMX-AGY-209	VMX-AGY-301	VMX-AGY-303
195	55	110	132	192	60	60	60	150	200	VMX-AGY-301	VMX-AGY-303	VMX-AGY-305
242	75	132	160	242	75	75	75	200	250	VMX-AGY-303	VMX-AGY-305	-
302	90	160	200	302	100	100	100	250	300	VMX-AGY-305	-	-

- 1) Rated operational powers in kW as per IEC 60072-1 (primary series) corresponding to IEC current rating.
- 2) Rated operational powers in hp as per UL508 corresponding to FLA current rating.
- 3) The I_e and FLA rating applies for a maximum surrounding air temperature of 40°C. Above 40°C de-rate linearly by 2% of I_e or FLA per °C to a maximum of 60°C.
- 4) kW and Hp ratings applicable for VMX-AGY-101-6 to VMX-AGY-305-6 models only.
- 5) For VMX-AGY-101 to VMX-AGY-209 models, a higher duty cycle F-S is possible with optional fan fitted as indicated in Fan option table. For VMX-AGY-301 to VMX-AGY-305 models with fans fitted as standard, consult Motortronics UK for higher duties.

Electrical Installation (continued)

Short Circuit Protection – VMX-Agility Frame Size 1										
Type designation (VMX-AGY-)			101-4 101-6	103-4 103-6	105-4 105-4	107-4 107-6	109-4 109-6	111-4 111-6	113-4	113-6
Rated operational current	I_e	A	17	22	29	35	41	55	66	66
Rated conditional short circuit current	I_q	kA	5	5	5	5	5	5	5	10
Class J time-delay fuse #1	Maximum rating Z_1	A	30	40	50	60	70	100	125	125
UL Listed inverse-time delay circuit breaker #1	Maximum rating Z_2	A	60	60	60	60	60	150	150	150
Semiconductor fuse (class aR) #2	Type		Mersen 6,9 URD 30 __ Bussmann 170M30__ Bussmann 170M31__ Bussmann 170M32__ SIBA 20 61__				Mersen 6,9 URD 31 __ Bussmann 170M40__ Bussmann 170M41__ Bussmann 170M42__ SIBA 20 61__			
	Fuse rating	A	160A	160A	200A	200A	250A	250A	250A	250A

Short Circuit Protection – VMX-Agility Frame Size 2 & 3										
Type designation (VMX-AGY-)			201-4 201-6	203-4 203-6	205-4 205-4	207-4 207-6	209-4 209-6	301-4 301-6	303-4 303-6	305-4 305-6
Rated operational current	I_e	A	80	106	132	160	195	242	302	361
Rated conditional short circuit current	I_q	kA	10	10	10	10	10	18	18	18
Class J time-delay fuse #1	Maximum rating Z_1	A	150	200	250	300	400	450	600	600
UL Listed inverse-time delay circuit breaker #1	Maximum rating Z_2	A	250	300	350	450	500	700	800	800
Semiconductor fuse (class aR) #2	Type		Mersen 6,9 URD 31__ Bussmann 170M40__ Bussmann 170M41__ Bussmann 170M42__ SIBA 20 61__				Mersen 6,9 URD 33__ Bussmann 170M60__ Bussmann 170M61__ Bussmann 170M62__ SIBA 20 63__			
	Fuse rating	A	400A	400A	550A	550A	550A	800A	900A	1000A

1. Suitable For Use On A Circuit Capable Of Delivering Not More Than I_q rms Symmetrical Amperes, 600Volts Maximum, When Protected by Class J Time Delay Fuses with a Maximum Rating of Z_1 or by a Circuit Breaker with a Maximum Rating of Z_2 .

2. Correctly selected semiconductor fuses can provide additional protection against damage to the VMX-agility unit (this is sometimes referred to as type 2 co-ordination). These semiconductor fuses are recommended to provide this increased protection.

Electrical Installation (continued)

Electromagnetic Compatibility

Electromagnetic Compatibility		
EMC Emission levels	EN 55011	Class A ¹
EMC Immunity levels	IEC 61000-4-2	8kV/air discharge or 4kV/contact discharge
	IEC 61000-4-3	10 V/m
	IEC 61000-4-4	2kV/5kHz (main and power ports)
		1kV/5kHz (signal ports)
	IEC 61000-4-5	2kV line-to-ground 1kV line-to-line
IEC 61000-4-6	10V	
¹ NOTICE: This product has been designed for environment A. Use of this product in environment B may cause unwanted electromagnetic disturbances, in which case the user may be required to take adequate mitigation measures		

Fan Option	
VMX-Agility model	Maximum duty cycle F-S with optional fan fitted
VMX-AGY-101 to VMX-AGY-203	90-40 (40 cycles per hour)
VMX-AGY-205	90-30 (30 cycles per hour)
VMX-AGY-207	90-20 (20 cycles per hour)
VMX-AGY-209	90-10 (10 cycles per hour)



VMX-AGY-301 – 305 have permanently fitted fans

Electrical Installation (continued)

Wire Sizes and Torques						
Terminal		Models	Wire/Busbar Size		Torque	
			Metric	Imperial	Nm	lb-in
Main Terminals Cu STR 75°C only	Terminal	VMX-AGY-101 to VMX-AGY-113	2.5 - 70mm ²	12- 2/0AWG	9	80
		VMX-AGY-201 to VMX-AGY-209	4 - 185mm ²	12 – 350MCM	14	124
	M10 bolt	VMX-AGY-301 to VMX-AGY-305	2 x 95mm ²	2 x 4/0AWG	28	248
Control terminals		All models	0.2–1.5mm ²	24-16AWG	0.5	4.5
Protective Earth ¹⁾ Cu only	M6 screw	VMX-AGY-101	≥ 4mm ²	≥ 12AWG	8	71
		VMX-AGY-103 to VMX-AGY-111	≥ 6mm ²	≥ 10AWG		
		VMX-AGY-113 to VMX-AGY-203	≥ 10mm ²	≥ 8AWG		
	M8 screw	VMX-AGY-205 to VMX-AGY-209	≥ 16mm ²	≥ 6AWG	12	106
	M8 Stud	VMX-AGY-301	≥ 25mm ²	≥ 4AWG		
		VMX-AGY-303 to VMX-AGY-305	≥ 35mm ²	≥ 3AWG		

¹⁾ Protective Earth wire size based on bonding conductor requirements of UL508 Table 6.4 and UL508A Table 15.1.

Electrical Installation (continued)

Motor Overload Protection

VMX-agility™ provides full motor overload protection, configurable through the user interface. Overload trip settings are determined by the Motor Current setting and the Trip Class setting. Trip class choices are Class 10, Class 20, and Class 30. The VMX-agility™ soft starters are protected using full I²T motor overload with memory. See Appendix 1 for sizing guide.

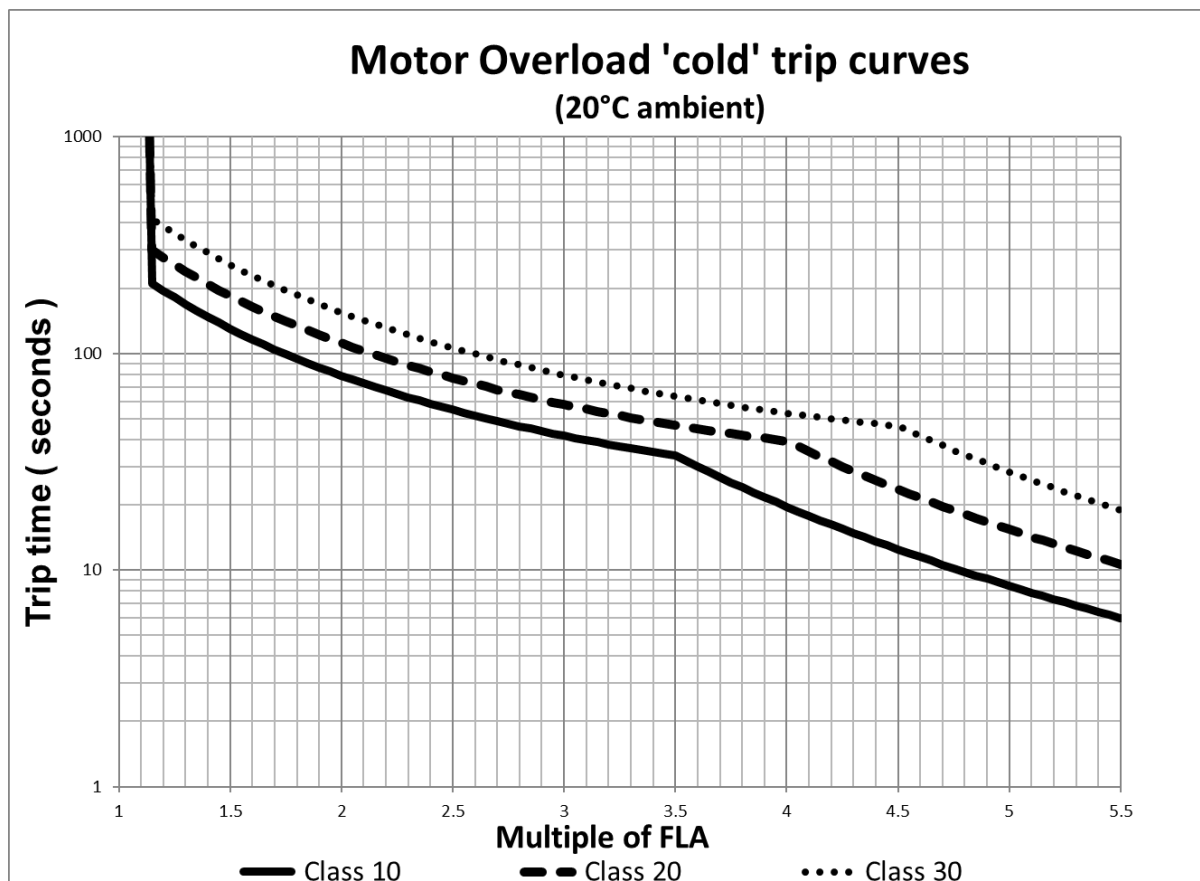

Please note: When the overload has tripped, there is a forced cooling time to allow the overload to recover before the next start.

The 'warm' trip times are 50% of the 'cold' trip time.



Electrical Installation (continued)

Electrical Connections

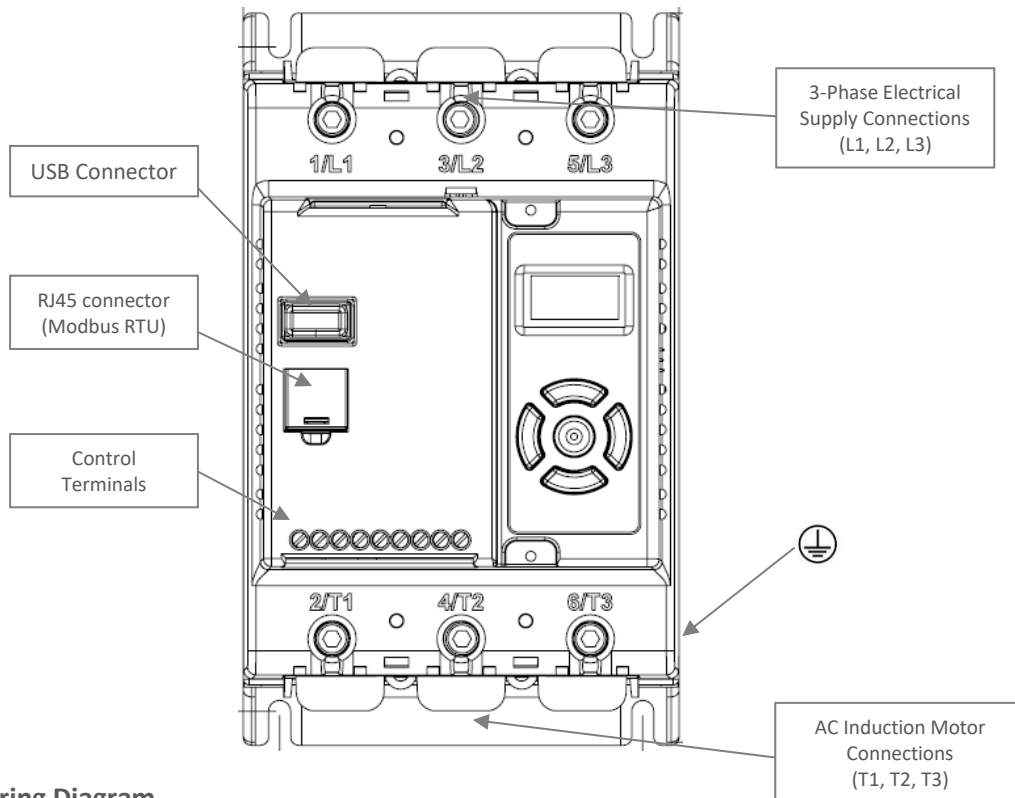

Main Circuit Wiring Diagram

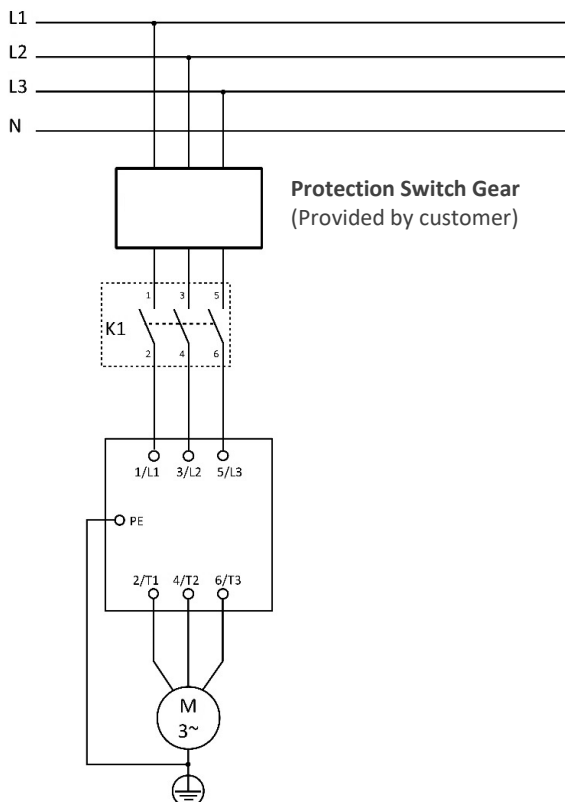

Electrical Installation (continued)

Single Phase Operation

VMX-agility soft starts may be operated with a single-phase supply and motor. The base rating of the unit is unchanged.

Electrical Connection

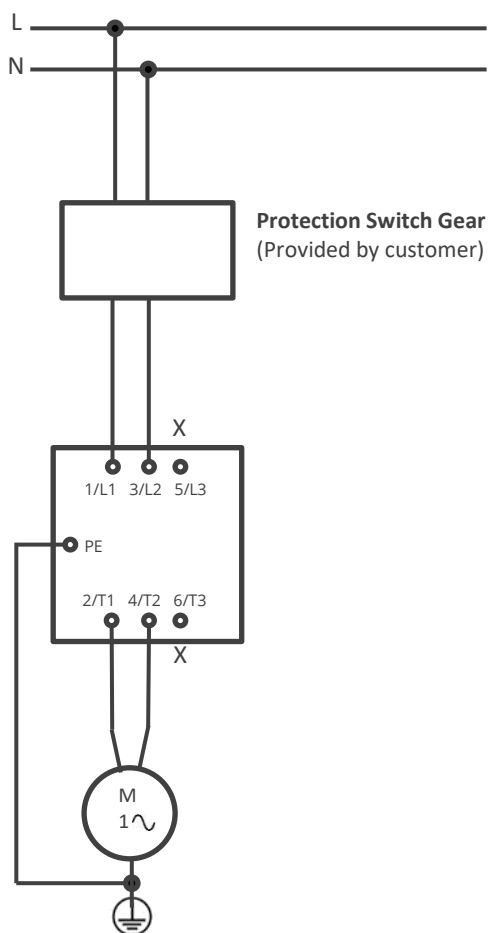

For single phase operation the mode of the soft start must be set correctly in the Advanced menu:

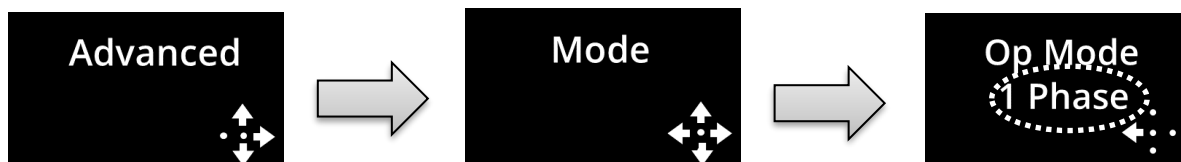

Electrical Installation (continued)

Control Terminal Connection

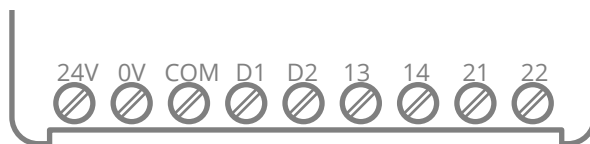

Control Terminal Functions

Terminal	Description	Function Selectable	Note
24Vdc	Control Supply +Us	No	#1
0V	Control Supply -Us	No	
COM	Digital Inputs Common	No	
D1	Digital Input 1	No	#2
D2	Digital Input 2	Yes	#2
13/14	Main Contactor Control (Run Relay)	Yes	#3
21/22	Fault Relay	Yes	#3

- #1 24Vdc Specification: See General Specification table (Page 15) for VA rating. Residual ripple < 100mV, spikes/switching peaks < 240mV. Turn On/Off response no overshoot of Vout, Overvoltage voltage protection output voltage must be clamped <30Vdc
- #2 The voltage applied to the digital inputs D1 and D2 must not exceed 24Vdc
- #3 230Vac, 1A, AC15. 30Vdc, 0.5A resistive

Digital Input 2 (D2) Selectable Functions

Different functions may be assigned to Digital Input 2 in the I/O menu. Available assignments are:

Reset

Hold Start Ramp

Enable

Fire Mode (In Fire Mode all trips are disabled)

Digital Outputs Selectable Functions (13/14 and 21/22)

The output may be mapped to Fault, Top-of-Ramp indication or Auto-Reset Pending or exceeded.

Electrical Installation (continued)

3-Wire Control Circuit Wiring Diagram

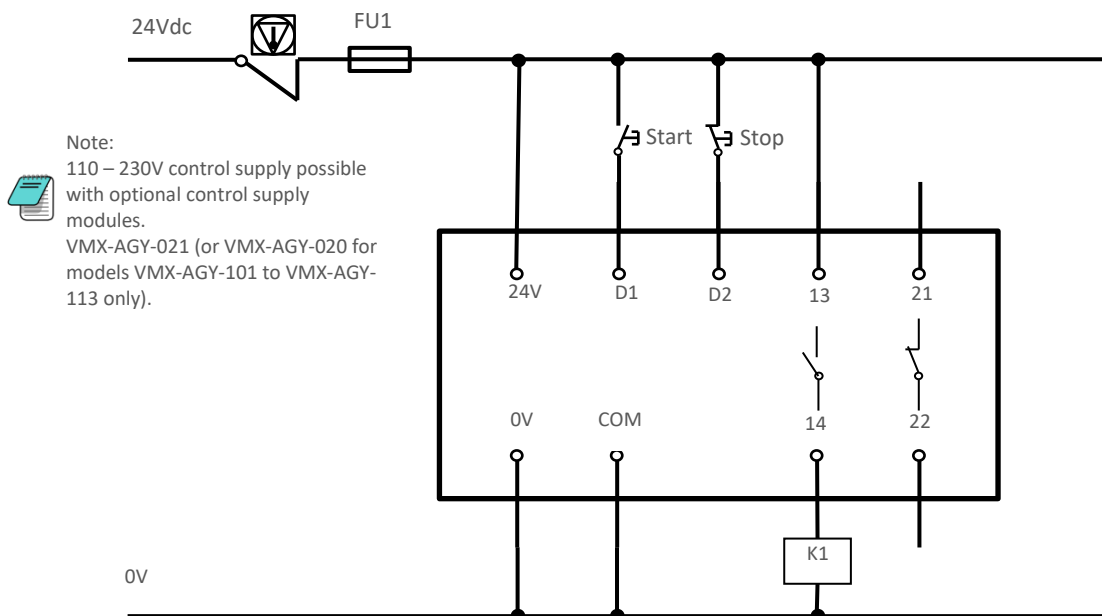

2-Wire Control Wiring Diagram

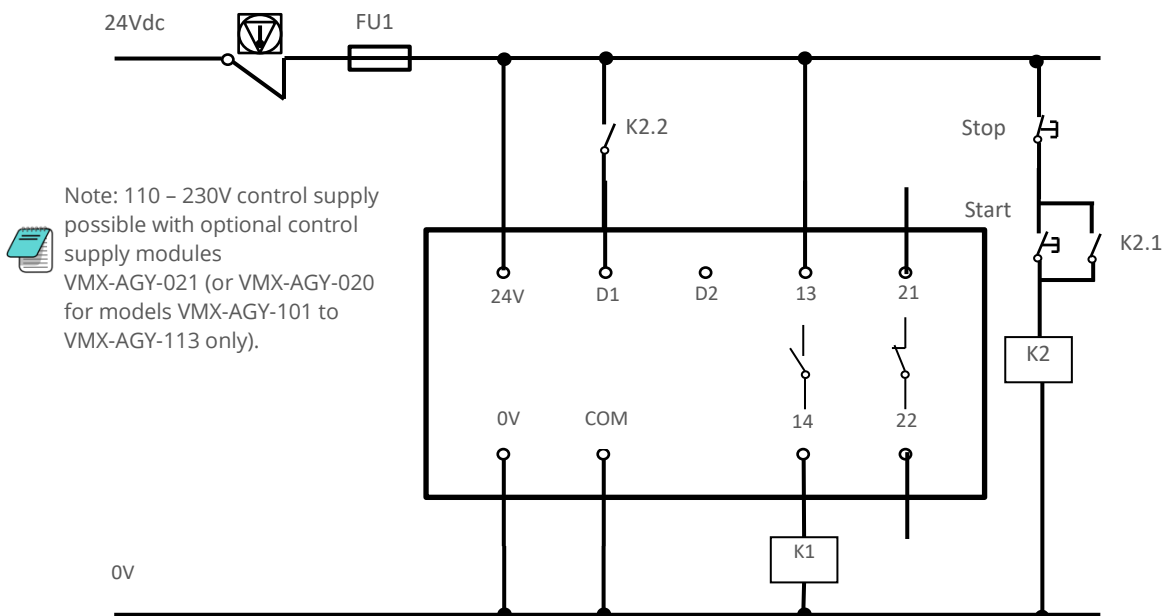

Configuration and Parameters (continued)

Display and Controls



- ① Status messages
- ② Instantaneous motor current
- ③ Control scheme: Local, Control terminal, Modbus RTU
- ④ Keypad guidance wizard: Displays which keys are valid for specific menu items
- ⑤ Motor overload level; 0 to 100%
- ⑥ Control keypad
- ⑦ Status LED (incorporated into centre button) Green/Red

Keypad Guidance Examples



All keys active



Left & Right keys active



Right, Down & Centre keys active

Note: A flashing centre button indicates that a menu item may be selected or saved.

Configuration and Parameters (continued)

Operation - Local Motor Start



Example Navigation Method

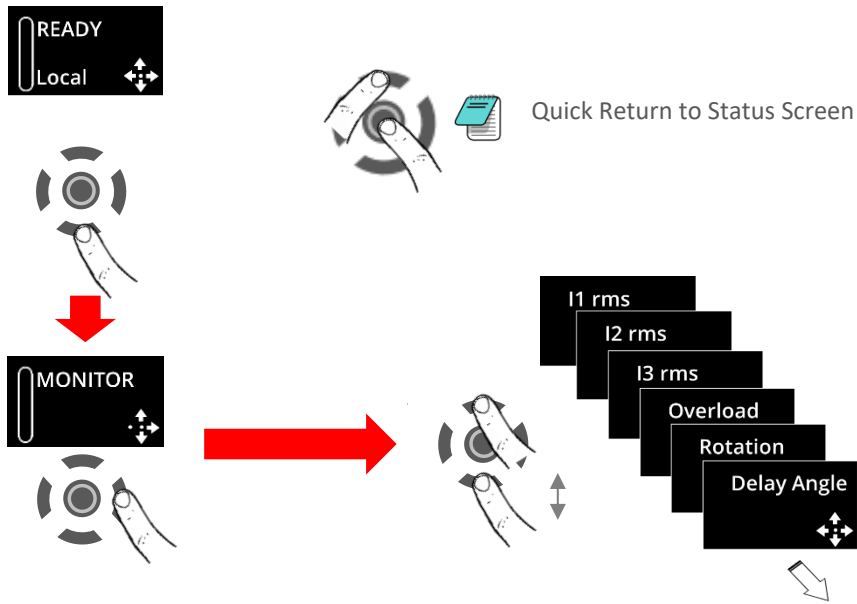

Auto Application Setup

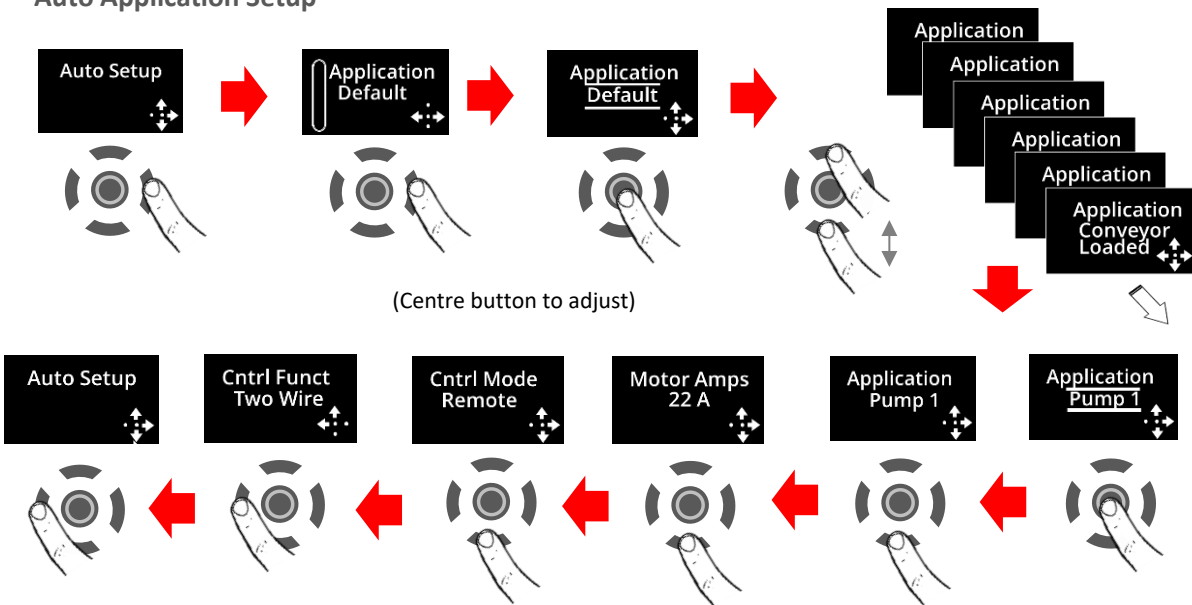

Configuration and Parameters (continued)

Auto Setup Procedure (Auto App)

Allows the user to change all of the parameters at once to settings that are typical for general applications. One or more parameters as can be adjusted to fine tune the settings for your specific application.

Setup by Individual Parameter Settings (Advanced)

Allows the user to change the parameter settings one at a time.

Auto Application Setup Parameter Settings

	Initial Volts	Start Time	Stop Time	Trip Class	Current Limit	Current Limit Time
Unit	%	s	s	-	*FLC	s
Default	20%	10	0	10	3.5	30
Heavy	40%	10	0	20	4	40
Agitator	30%	10	0	10	3.5	25
Compressor 1	40%	15	0	20	3.5	25
Compressor 2	35%	7	0	10	3.5	25
Conveyor Loaded	10%	10	7	20	5.5	30
Conveyor Unloaded	10%	10	7	10	3.5	30
Crusher	40%	10	0	30	3.5	60
Fan High Inertia	40%	10	0	30	3.5	60
Fan Low Inertia	30%	15	0	10	3.5	30
Grinder	40%	10	0	20	3.5	40
Mill	40%	10	0	20	3.5	40
Mixer	10%	10	0	20	4	25
Moulding M/C	10%	10	0	10	4.5	25
Press Flywheel	40%	10	0	20	3.5	40
Pump 1	10%	10	60	10	3.5	25
Pump 2	10%	10	60	20	3.5	25
PumpJack	40%	10	0	20	3.5	40
SawBand	10%	10	0	10	3.5	25
SawCircular	40%	10	0	20	3.5	40
Screen Vibrating	40%	10	0	20	4.5	40
Shredder	40%	10	0	30	3.5	60
Wood Chipper	40%	10	0	30	3.5	60

Compressor 1 = Centrifugal, Reciprocating, Rotary Screw

Compressor 2 = Rotary Vane, Scroll

Pump 1 = Submersible: Centrifugal, Rotodynamic

Pump 2 = Positive Displacement: Reciprocating, Rotary

Menu Structure

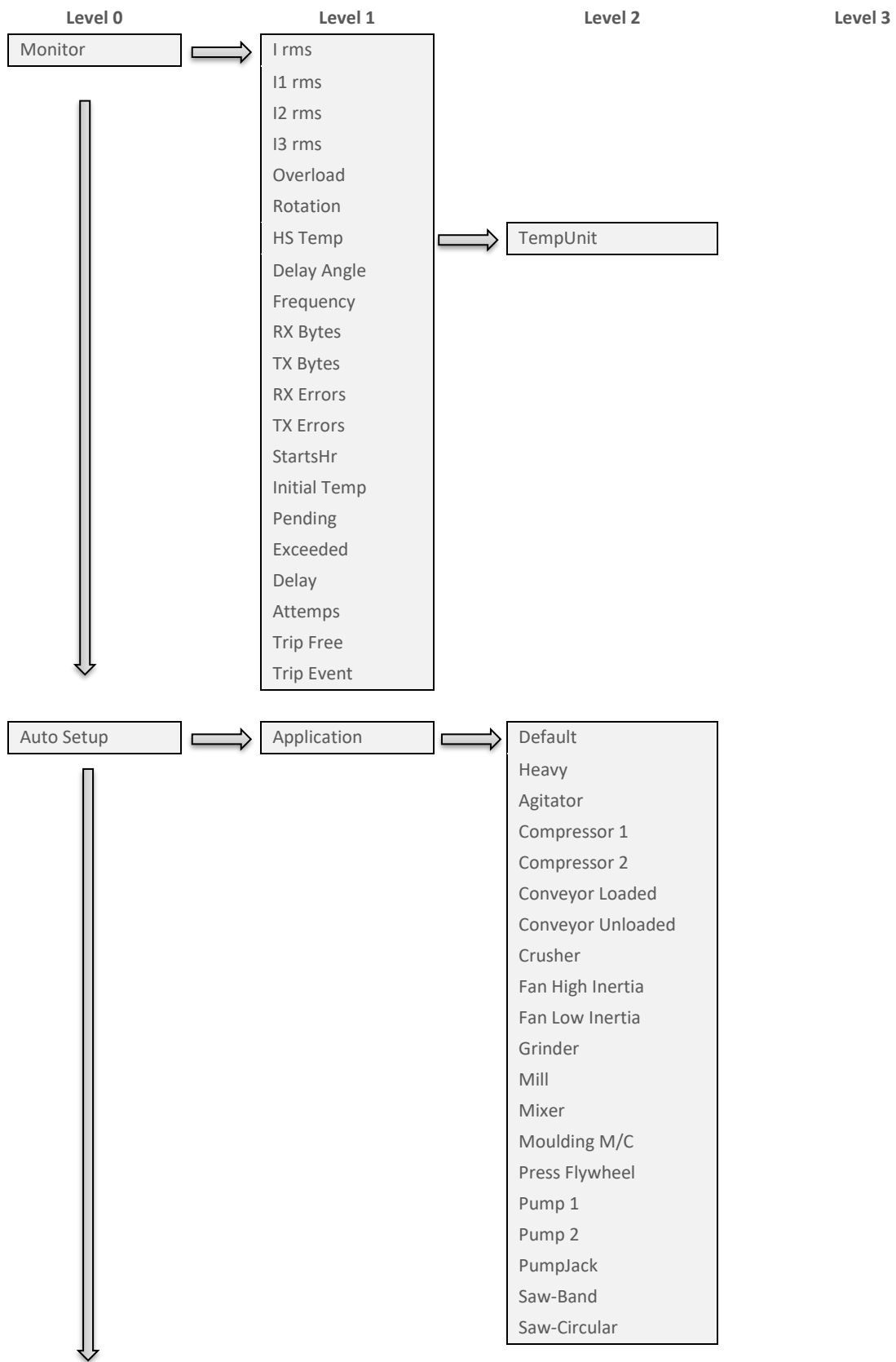

Menu Structure (continued)

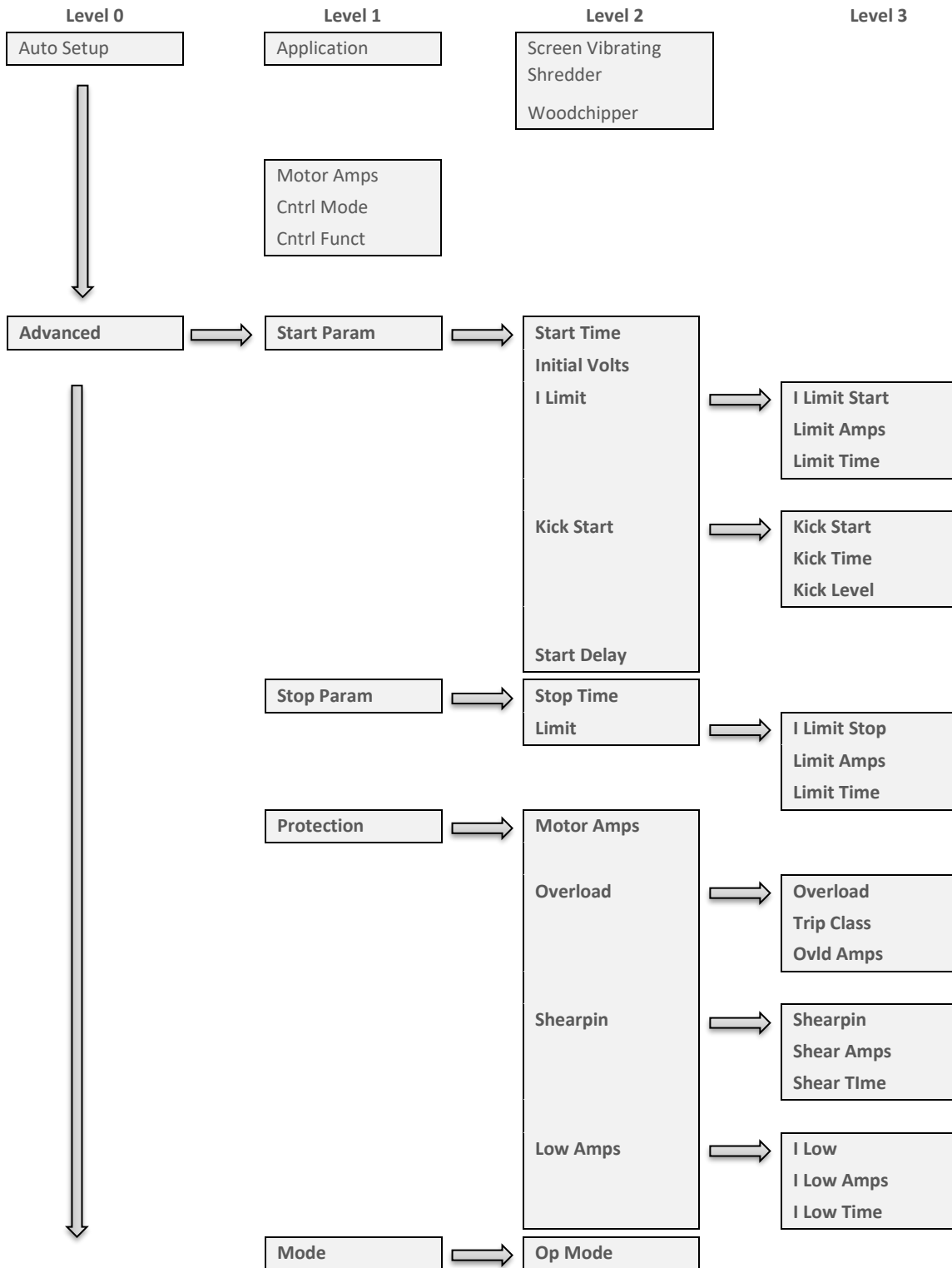

Menu Structure (continued)

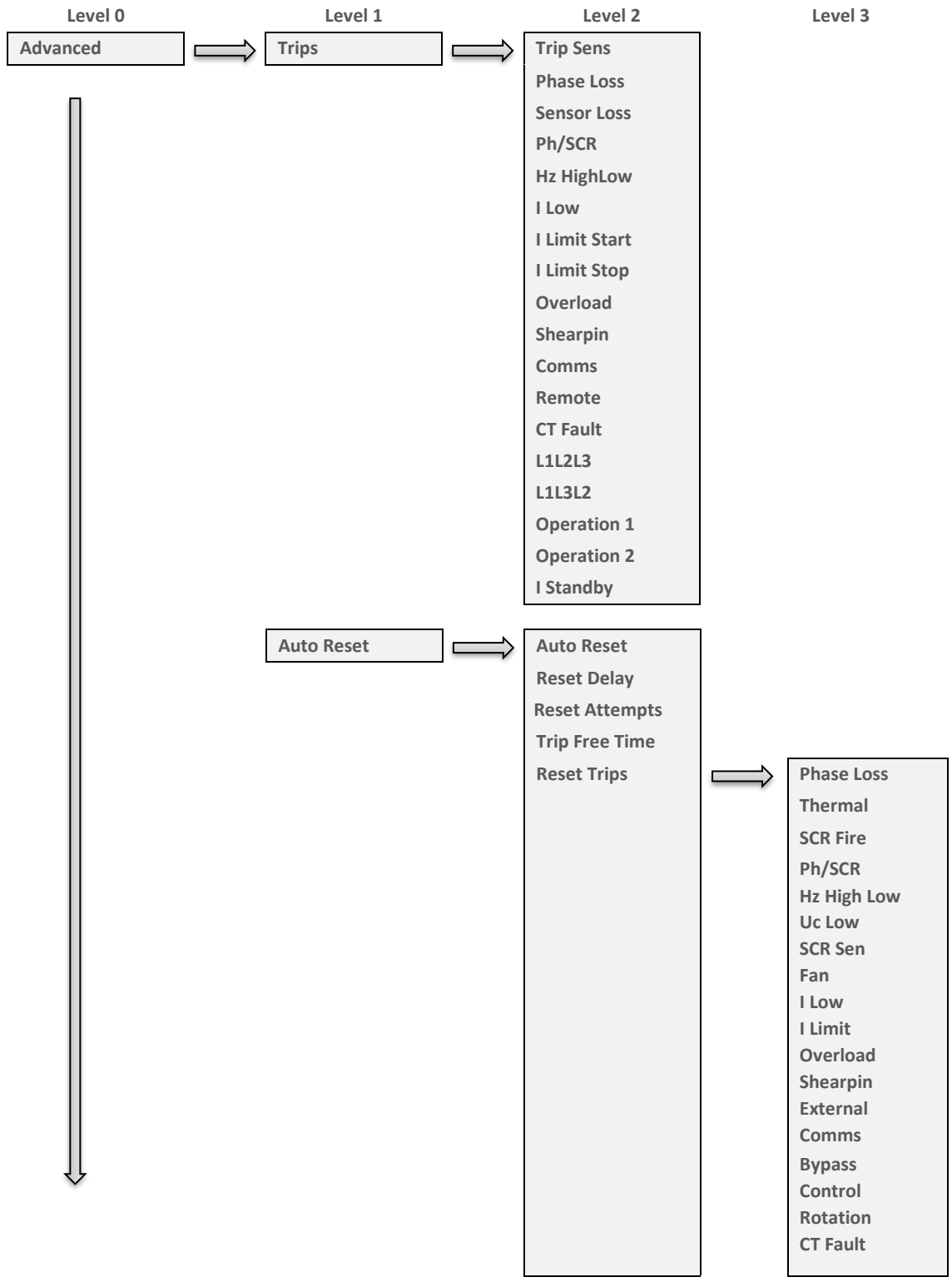

Menu Structure (continued)

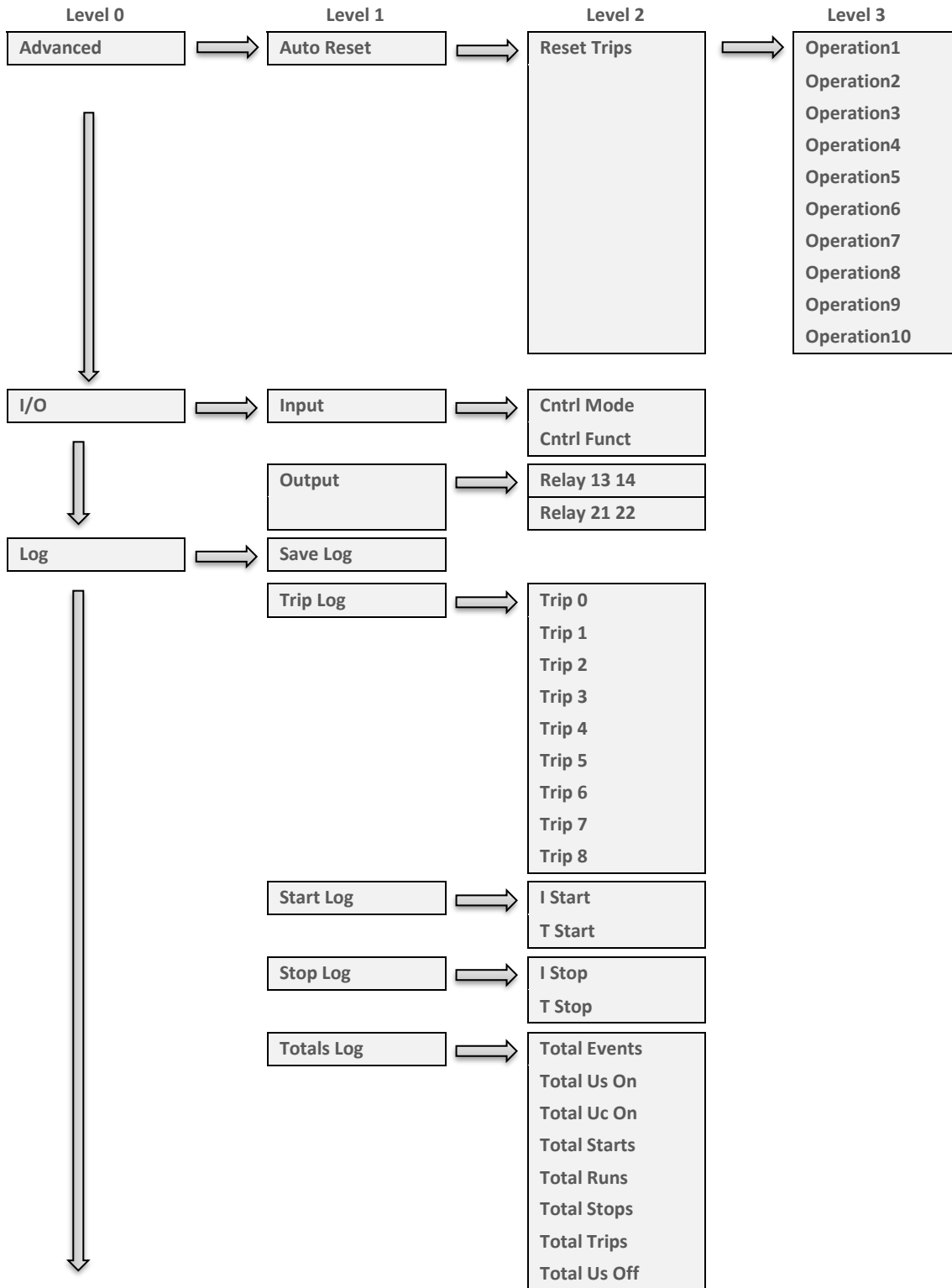



Menu Structure (continued)

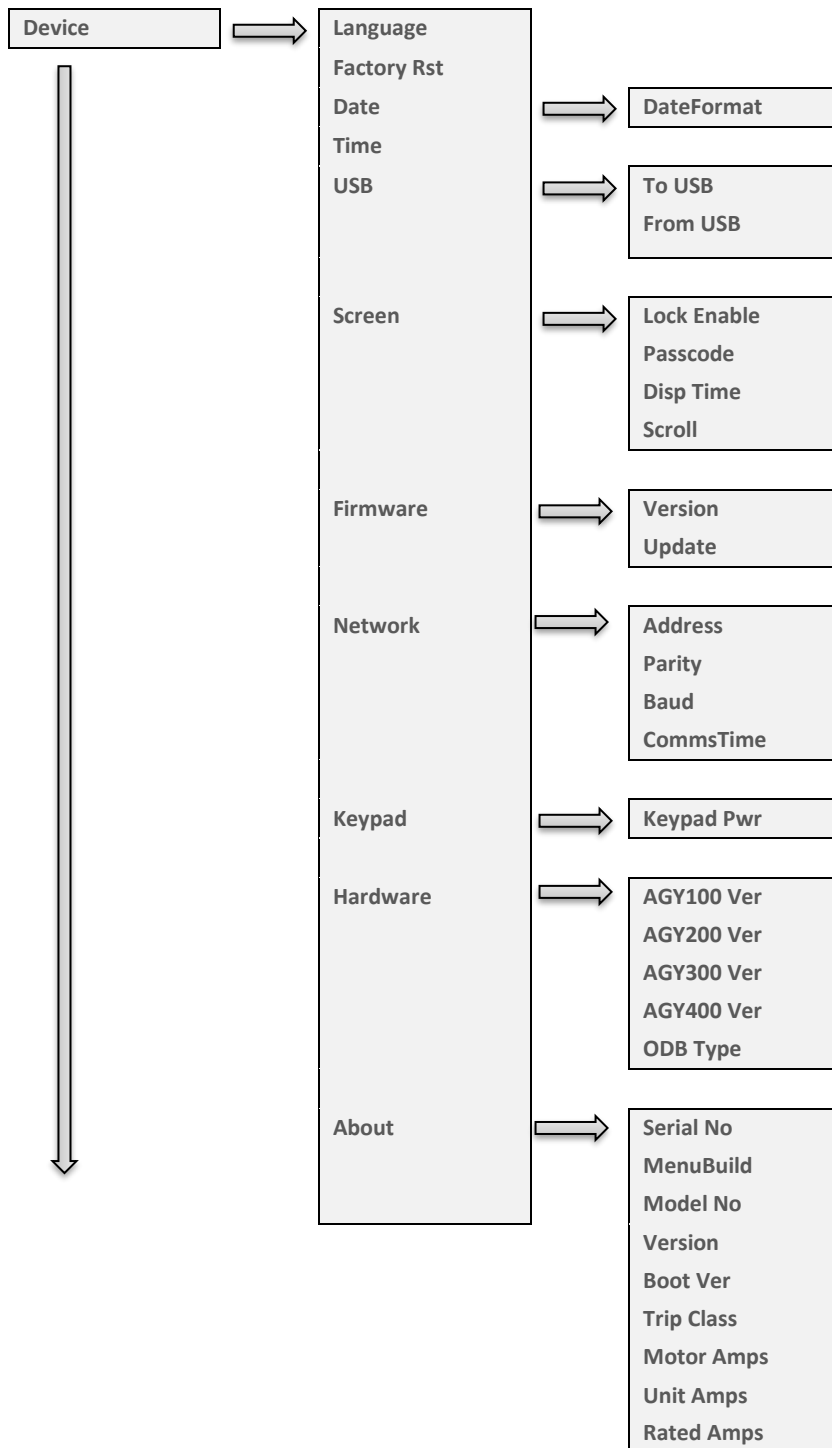

Function Descriptions

Address	Sets the Modbus address number
Application	<p>The unit has numerous pre-set applications built in as standard Select the application best suited to the load The selected application will automatically change several parameters and functions Depending on the application loaded the "Trip Class" may also change</p>
Baud	<p>Sets the serial communications baud rate The available baud rates are 9600 19200 38400 57600 or 115200</p>
Boot Ver	Software Version for the Bootloader
Cntrl Funct	<p>Allows the Digital inputs to be mapped to different functions Cntrl Mode must be set to "Remote" Two Wire: D1 = Start (Reset) / Stop Three Wire: D1 = Start (Reset) D2 = Stop D2 Reset, D2 HoldStart , D2 Enable , D2 FireMode : Programs D2 as shown</p>
Cntrl Mode	<p>Selects the method for starting and controlling the motor Local: Control using the button on the keypad Remote: Control using the terminals Modbus: Control via Modbus network</p>
Comms	<p>Detects if the communications bus has failed or become inactive To keep the bus active there must be at least one Modbus read or write (any PNU) during the "Comms Time" period (ModbusPNU 147) Trip On: Communication trip enabled Trip Off: External Trip is disabled</p>
CommsTime	<p>Communications trip Timeout period To prevent a 'Communications Trip' (if enabled) the bus must be kept active To keep the bus active there must be at least one Modbus read or write (any PNU) during the "Timeout ms" period</p>
Cont Delay	<p>Time allowed for external contactors to close Increase if contactors are driven by buffer relays or motor trips on phase loss when start signal applied Decrease if response to start signal needs to be improved</p>

Function Descriptions (continued)

CT Fault	<p>Detects if the internal current sensors have failed or reading a very low level</p> <p>Trip On: The unit will trip if the internal current sensors fail or the current measured falls to a very low level</p> <p>Trip Off: Will continue to operate even if the sensor has failed. Measurements and overload protection may be effected</p>
Date	<p>Enter current date</p> <p>Date format can be set to either dd/mm/yyyy or mm/dd/yyyy. Refer to "Date format" parameter</p>
DateFormat	<p>Allows the date format to be changed</p> <p>dd/mm/yy or mm/dd/yy or yy/mm/dd</p>
Delay Angle	<p>Internal firing delay angle in Degrees</p> <p>Displayed for diagnostic purposes</p>
Disp Time	<p>Time for backlight on display</p> <p>After the period set the back light on the screen will turn off</p> <p>To reactivate touch screen anywhere. To disable set to 0</p>
Factory Rst	<p>Restores the unit to the factory defaults</p>
Fan Fault	<p>Detects if the cooling fans have failed</p> <p>Trip On: The unit trips if the cooling fans fitted to the unit fail</p> <p>Trip Off: Will continue to operate and is likely to trip on a thermal trip as the heatsink will not be sufficiently cooled</p>
Fire Mode	<p>A special feature that allows the unit to operate with ALL of the trips OFF</p> <p>Set " Cntrl Funct" to "D2 FireMode" , Enabled when D2 is high</p> <p>Although the unit will keep running in this mode it may become damaged</p> <p>In some instances, the damage may inhibit a subsequent starts</p> <p>This is only to be used in an emergency</p>
Frequency	<p>The frequency of the 3-phase supply</p>
From USB	<p>Allows the user to load parameters stored on a USB flash drive</p> <p>Uploads the parameters from the USB drive to the unit</p> <p>Data is stored in CSV format</p>
HS Temp C	<p>The temperature of the internal unit heatsink</p> <p>The unit will trip when the heatsink temperature exceeds 80°C</p>

Function Descriptions (continued)

HS Temp F	<p>The temperature of the internal unit heatsink</p> <p>The unit will trip when the heatsink temperature exceeds 176°F</p> <p>The optional cooling fans will turn on if this temperature exceeds 104°F</p>
I Limit	<p>Selects trip or continue if the current limit has been active for too long</p> <p>Trip On: The unit will trip</p> <p>Trip Off: The start will continue regardless of the motor current level</p>
I Low	<p>This can be used to detect if the motor is running lightly loaded</p> <p>Trip On: The unit will trip. This feature is not active during soft start and soft stop</p> <p>Trip Off: The unit will continue to operate regardless of motor current</p>
I rms	<p>The RMS motor current</p> <p>Indicates average current of the 3 phases</p>
I Start	<p>Displays the peak current during the last start</p>
I Stop	<p>Displays the peak current during the last stop</p>
I1 rms	<p>The RMS current on phase L1</p>
I2 rms	<p>The RMS current on phase L2</p>
I3 rms	<p>The RMS current on phase L3</p>
Initial Volts	<p>Percentage of the supply voltage applied to motor at the beginning of the soft start</p> <p>Increase to provide more torque If the load fails to break away</p> <p>Decrease if the motor accelerates too quickly</p>
Kick Level	<p>Percentage of the supply voltage applied to the motor during the 'kick' period</p> <p>Increase to provide more torque If the load fails to break away</p> <p>Decrease if the motor accelerates too quickly</p>
Kick Start	<p>Applies a short duration torque pulse to dislodge 'sticky' loads</p> <p>On: The torque pulse is applied at start-up when complete the torque drops to the "Initial Volts"</p> <p>Off: The initial starting torque is defined by the "Initial Volts"</p>

Function Descriptions (continued)

Kick Time	Time that the torque pulse is applied to load Increase to provide more torque If the load fails to break away Decrease if the motor accelerates too quickly
Last Trip	
Limit Amps	The current in Amps at which the soft Start ramp is held Normally set to 350% of motor FLC Increase if motor fails to accelerate at required rate The "Limit Amps" will affect actual time to start If set too low the motor may not accelerate to full speed
Limit Time	The maximum time allowed for the current limit If the current limit is still active at the end of this period, the unit will either 'Trip' or 'continue'
MenuBuild	Menu Version
Modbus Enable	Enable using Modbus On: The unit is enabled Off: The unit is disabled
Modbus Reset	Reset using Modbus On: The initial state required for a reset Off: The final state required for a reset To reset pulse high and then low
Modbus Start	Start / Stop using Modbus On: Starts the unit Off: Stops or Soft stops the unit
Model No	The device Model number stored at the point of manufacture
Motor Amps	This should be set to the Full Load Current shown on the motor plate The overload works with multiples of the set "Motor Amps" Also referred to as Motor FLA
MotorState	Indicates the unit operating State
Op Mode	

Function Descriptions (continued)

Overheat	<p>Detects if the internal temperature sensor has malfunctioned</p> <p>Trip On: The unit will trip if the internal temperature sensor malfunctions</p> <p>Trip Off: The unit will continue to operate even if the temperature sensor has malfunctioned</p> <p>Operating with the Trip Off for prolonged periods may result in SCR failure</p>
Overload	<p>The unit has an "Overload" function that is an electronic equivalent to a thermal overload</p> <p>Overload displays the overload capacity which is a measure of how close the unit to tripping on "Overload Trip"</p> <p>When "Irms" is greater than the "Overload Amps" the "Overload" increases in accordance with the "Trip Class"</p> <p>When "Current Irms" is less than "Overload Level" the "Overload" decreases exponentially (if greater than 50%)</p> <p>When the "Overload" reaches 100% the unit will trip</p> <p>During situations when "Motor Amps" is equal to "unit Amps" the overload will indicate 50%</p>
Overload Trip	<p>The unit has an "Overload" function that is an electronic equivalent to a thermal overload</p> <p>Trip On: The unit will trip when the "Overload" capacity (Modbus PNU 27) exceeds 100%</p> <p>Trip Off: The unit will continue to operate regardless of motor current level</p>
Ovld Amps	<p>Determines the level in Amps at which the overload will start</p> <p>Normally set to 115% of the set "Motor Amps"</p> <p>Reduce to speed up trip response</p>
Parity	<p>Sets the serial communications parity bit</p> <p>The available parity options are None Even Odd</p> <p>Also, sets the stop bits. No parity uses 2 stop bits. Odd or even parity uses 1 stop bit</p>
Patch Addr 1 through 16	<p>Used to arrange the Modbus Parameters into Groups</p> <p>Refer to MAN-AGY-002-V01 for more details</p>

Function Descriptions (continued)

Ph/SCR	<p>Detects for various issues when "Starting" or " Stopping"</p> <p>Detects for input phase loss/output phase loss/SCR misfire</p> <p>Trip On: Trips if there is an input phase loss/motor side phase loss/SCR misfire</p> <p>Trip Off: The unit will attempt to run although the operation may be erratic</p> <p>Operating in this mode for prolonged periods may result in SCR failure</p>
Phase Loss	<p>Detects for various issues when the start signal is applied</p> <p>Detects for input phase loss/input phase relationship</p> <p>Trip On: Trips if there is an input phase loss/supply out of balance</p> <p>Trip Off: The unit will attempt to run although the operation may be erratic</p> <p>Operating in this mode for prolonged periods may result in SCR failure</p>
Rated Amps	Unit Class20/Class30 Current Rating
RelayFunct	<p>Allows the n/c relay (21 -22) to be reconfigured</p> <p>Available options are 22 = TOR or 22 = ERR</p>
Remote	<p>For safety reasons the unit will trip during some operations if the remote start signal is active</p> <p>Trip On: Trips if the remote start signal is active when the unit is powered up or a reset is applied</p> <p>Trip Off: The unit will not trip and may start unexpectedly if the start signal is accidentally left active</p>
Rotation	<p>Indicates the phase sequence of the incoming supply</p> <p>RYB = ABC = L1-L2-L3</p> <p>RBY = ACB = L1-L3-L2</p>
Save Log	<p>Download the full log file on to the USB stick</p> <p>The unit logs several parameters during normal and fault conditions</p> <p>Data is stored in CSV format. Please send all downloaded files to Motortronics UK on request</p>
Serial No.	The device serial number stored at the point of manufacture
Shear Amps	<p>The current in Amps that will cause a "Shear Trip"</p> <p>A trip will occur if the motor current is greater than the "Shear Amps" for the "Shear Time"</p>

Function Descriptions (continued)

Shear Time	The trip time for the Shearpin trip A trip will occur if the motor current is greater than the "Shear Amps" for the "Shear Time"
Shearpin	The Shearpin is an electronic equivalent of a mechanical Shearpin Trip On: The unit will trip. This feature is not active during soft start and soft stop Trip Off: The unit will continue to operate regardless of motor current level
Start Time	Time taken to soft start from the "Initial Volts" to the end of the start Normally set between 5 and 30 seconds Actual time to get to full voltage depends on the "Limit Amps" If set too long the motor can be at speed before the end of the time set
Stop Time	The time taken to soft stop from full voltage to the end of the stop Normally set between 15 and 30 seconds Actual time to get to the final voltage depends on the "Limit Amps" If set too long the motor may reach zero speed before the end of the time set
Store Param	Saves all Read/Write parameters to non-volatile memory Yes: Parameters are permanently written No: Parameters remain changed until next power cycle
System	Detects if the Control Board has failed to operate normally Trip On: System Trip enabled Trip Off: System Trip disabled
T Start	Displays the time of the last start
T Stop	Displays the time of the last stop
Tempunit	Selects °C or °F for displayed temperatures °C: All displayed temperatures are °C °F: All displayed temperatures are °F
Time	Allows the time to be changed to 'local' time By default, the time is set to GMT

Function Descriptions (continued)

To USB	<p>Allows the user to save parameters</p> <p>Downloads the parameters from the unit to the USB drive</p> <p>Data is stored in CSV format</p>
Total Events	The total number of events that have been recorded in the log file
Total Run	<p>The total number of times the unit as successfully got to the "Running" State</p> <p>The Running state is active when the unit is operating at full voltage</p> <p>When operating at full voltage the internal bypass relays are closed</p>
Total Starts	The total number of successful starts
Total Uc On	<p>The total number of times the unit has been powered up</p> <p>The unit is powered up by applying a voltage to Uc</p> <p>Uc will be 24V or 110V/230V depending on model</p>
Total Uc Off	<p>The total number of times the unit has been powered down</p> <p>The unit is powered down by removing the voltage at Uc</p> <p>Uc will be 24V or 110V / 230V depending on model</p>

Function Descriptions (continued)

Trip 0	Displays the last Fault trip
Trip 1	Displays the last Fault trip -1
Trip 2	Displays the last Fault trip -2
Trip 3	Displays the last Fault trip -3
Trip 4	Displays the last Fault trip -4
Trip 5	Displays the last Fault trip -5
Trip 6	Displays the last Fault trip -6
Trip 7	Displays the last Fault trip -7
Trip 8	Displays the last Fault trip -8
Unit Amps	Unit Class10 Current Rating
Version	Software Version for the Main control PCB Software version recorded in log file
Window 1 though 24	Used to arrange the Modbus Parameters into Groups
Window Code	Used to arrange the Modbus Parameters into Groups
Window View	Used to arrange the Modbus Parameters into Groups

Trip and Fault Codes

Trip Code	Trip Name	Description
101-199	Ph Loss	Input phase voltage missing or motor discontinuity at the instant of startup Check all incoming and outgoing connections If a main contactor is being controlled by a digital output check contactor delay is sufficient
201-299	Thermal	Internal heatsink temperature has exceeded 90°C It is possible the Unit is operating outside specified limits Check enclosure ventilation and airflow around the Unit. If the unit trips immediately the internal temperature sensor could be faulty
301-399	Ph/SCR	Input phase voltage missing or motor discontinuity or SCR failure Check all incoming and outgoing connections ISOLATE SUPPLY Check by measuring the resistance between L1-T1 L3-T3 (Anything < 10R is assumed short circuit)
601-699	Uc Low	The internal control supply of the Unit level has fallen to a low level Can be caused by a weak 24VDC control supply Ensure 24VDC supply meets the requirements specified in the Quick Start Guide
1101-1199	Low Amp	The motor current has been lower than the low trip level for the low trip time This trip is not active during soft start and soft stop and is "off" by default If the low current trip is not required turn "off" in "Trip Settings"
1201-1299	Limit	The motor has been held in current limit longer than the "Current limit Time" It is likely that the current limit level has been set too low for the application Increase the current limit level or timeout period
1301-1399	Overload	The "Overload" has exceeded 100% The Unit is attempting to start an application that is outside its capacity or it is starting too often Refer to the overload trip curves to determine whether the Unit has been sized correctly
1401-1499	Shear	The motor current has been higher than the "Shearpin Trip Level" for the trip time This trip is not active during soft start and soft stop and is "off" by default If Shearpin trip is not required turn "off" in "Trip Settings"

Trip and Fault Codes (continued)

Trip Code	Trip Name	Description
1701-1799	Comms	Communications failure The command or status PNU has not been polled in the time set in the "Timeout" period If the communication trip is disabled the Unit cannot be stopped in the communications fail
1801-1899	Bypass	One or more of the internal bypass relays has failed to close or open The internal bypass relay has failed or the control supply is too weak Ensure 24Vdc supply meets the requirements specified in the Quick Start Guide
2001-2099	Remote	The remote start signal is active The remote start signal was active during power up or Reset or Parameter Load Turn off remote or if Remote On trip is not required turn "off" in "Trip Settings"
2101-2199	Rotation	Checks the input phase rotation The phase rotation is opposite to that required Change phase rotation or if the trip is not required turn "off" in trip settings
2201-2299	Op1	Fail Safe operation A process associated with the Control Board has been affected and is unable to recover automatically
2301-2399	CT Fault	Current sensor failure One or more of the internal sensors used to measure current has failed or is reading a low value Check the connections to the supply and motor as disconnection will result in a zero current reading. Check the plate FLA of the motor being controlled is at least 25% of the "i-motor" rating
11001-11099	Op2 Pnu	Fail Safe operation A process associated with the Control Board has been affected and is unable to recover automatically
12001-12099	Op2 Mod	Fail Safe operation A process associated with the Control Board has been affected and is unable to recover automatically

Trip and Fault Codes (continued)

Trip Code	Trip Name	Description
13001-13099	Op2 Mon	Fail Safe operation A process associated with the Control Board has been affected and is unable to recover automatically
14001-14099	Op2 Men	Fail Safe operation A process associated with the Control Board has been affected and is unable to recover automatically
15001-15099	Op2 Keys	Fail Safe operation A process associated with the Control Board has been affected and is unable to recover automatically
16001-16099	Op2 Motr	Fail Safe operation A process associated with the Control Board has been affected and is unable to recover automatically
17001-17099	Op2 Log	Fail Safe operation A process associated with the Control Board has been affected and is unable to recover automatically
18001-18099	Op2 Disk	Fail Safe operation A process associated with the Control Board has been affected and is unable to recover automatically

Auto Reset Function

The Auto Reset feature automatically resets a selected number of faults and then attempts a start without user intervention. The time between the resets and the number of reset attempts are both programmable. If the Auto Reset has been successful, the Starter must operate trip free for a set time before the counters are re-initialised. If the number of attempts exceeds the set value, the Auto Reset terminates, and the counters will be re-initialised when a Reset or Stop signal is given by the user.



WARNING:

When Auto Reset is enabled, a tripped motor may restart automatically after the Reset Delay time. This may result in equipment damage or personal injury if the function is used in an unsuitable application. Do not use this function without considering applicable local, national, and international standards, regulations, or industry guidelines.

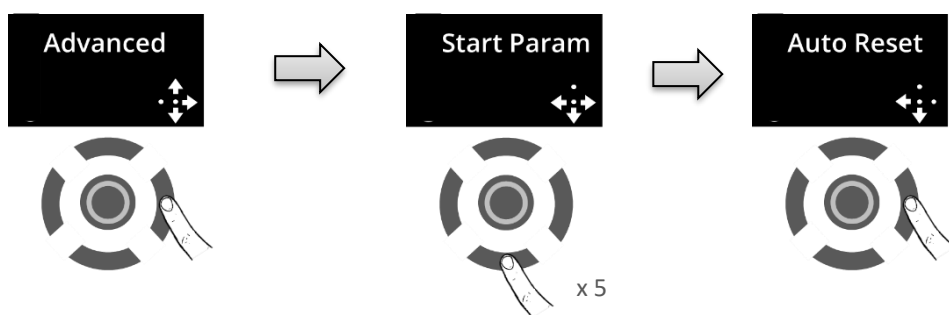
The Auto-Reset function is accessible from the Advanced Menu (see Auto-Reset section of parameter summaries):

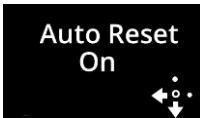
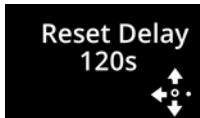

From the Auto Reset menu various functions are accessed:

	Toggles the Auto Reset On or Off
	Sets delay between trip and Auto Reset
	Number of permissible Auto Reset attempts

Auto Reset Function (continued)

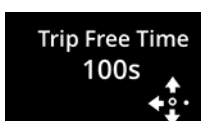

The time the unit must be trip free before the counter is set to zero

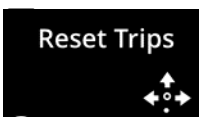

Press Right key to assign trips to Auto Reset function

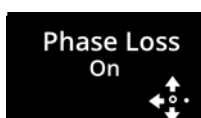

Example of trip assigned to Auto Reset function (Up/Down keys to view and select trips)

Auto Reset Assignable Trips

Phase Loss	Comms
Thermal	Bypass
ScrFire	Control
Ph/SCR	Remote
HzHighLow	Rotation
UcLow	Operation 1
SCRSen	CT Fault
Fan	Operation2
Spare900	Operation3
Spare1000	Operation4
I Low	Operation5
I Limit	Operation6
Overload	Operation7
Shearpin	Operation8
Spare1500	Operation9
External	Operation10

Auto Reset Function (continued)

Auto Reset Function Descriptions

AR Attempts	The number of Reset Attempts remaining
AR Delay	The amount of time remaining in the Reset Delay counter
AR Exceeded	Indicates that the maximum number of reset attempts has been reached Yes: The number of reset attempts has exceeded the value set No: The number of reset attempts has not exceeded the value set To map to digital output refer to PNU154/PNU300
AR Pending	Indicates that the Reset Delay counter is counting down Yes: The Auto Reset Delay is counting down No: The Auto Reset Delay is not counting down To map to digital output refer to PNU154/PNU300
AR Trip Event	The trip that occurred just prior to the auto reset
AR Trip Free	The amount of time remaining in the Trip Free Time counter



Auto Reset Function (continued)

Auto Reset	<p>Enables the Auto Reset Feature</p> <p>Refer to Auto Reset section for more details</p> <p>On: The Auto Reset feature is enabled</p> <p>Off: The Auto Reset feature is disabled and all counters will be re-initialised</p>
Bypass	<p>Allows the user to select whether the unit will auto reset if a Bypass Trip occurs</p> <p>On: The trip will auto reset when the Reset Delay reaches zero</p> <p>Off: The trip will not auto reset</p>
Comms	<p>Allows the user to select whether the unit will auto reset if a Comms Trip occurs</p> <p>On: The trip will auto reset when the Reset Delay reaches zero</p> <p>Off: The trip will not auto reset</p>
Control	<p>Allows the user to select whether the unit will auto reset if a Control Trip occurs</p> <p>On: The trip will auto reset when the Reset Delay reaches zero</p> <p>Off: The trip will not auto reset</p>
CT Fault	<p>Allows the user to select whether the unit will auto reset if a CT Fault Trip occurs</p> <p>On: The trip will auto reset when the Reset Delay reaches zero</p> <p>Off: The trip will not auto reset</p>
External	<p>Allows the user to select whether the unit will auto reset if a External Trip occurs</p> <p>On: The trip will auto reset when the Reset Delay reaches zero</p> <p>Off: The trip will not auto reset</p>

Auto Reset Function (continued)

Fan	<p>Allows the user to select whether the unit will auto reset if a Fan Trip occurs</p> <p>On: The trip will auto reset when the Reset Delay reaches zero</p> <p>Off: The trip will not auto reset</p>
HzHighLow	<p>Allows the user to select whether the unit will auto reset if a HzHighLow Trip occurs</p> <p>On: The trip will auto reset when the Reset Delay reaches zero</p> <p>Off: The trip will not auto reset</p>
I Limit	<p>Allows the user to select whether the unit will auto reset if a I Limit Trip occurs</p> <p>On: The trip will auto reset when the Reset Delay reaches zero</p> <p>Off: The trip will not auto reset</p>
Operation 1	<p>Allows the user to select whether the unit will auto reset if a Operation1 Trip occurs</p> <p>On: The trip will auto reset when the Reset Delay reaches zero</p> <p>Off: The trip will not auto reset</p>
Operation10	<p>Allows the user to select whether the unit will auto reset if a Operation10 Trip occurs</p> <p>On: The trip will auto reset when the Reset Delay reaches zero</p> <p>Off: The trip will not auto reset</p>
Operation2	<p>Allows the user to select whether the unit will auto reset if a Operation2 Trip occurs</p> <p>On: The trip will auto reset when the Reset Delay reaches zero</p> <p>Off: The trip will not auto reset</p>

Auto Reset Function (continued)

Operation3	<p>Allows the user to select whether the unit will auto reset if a Operation3 Trip occurs</p> <p>On: The trip will auto reset when the Reset Delay reaches zero</p> <p>Off: The trip will not auto reset</p>
Operation4	<p>Allows the user to select whether the unit will auto reset if a Operation4 Trip occurs</p> <p>On: The trip will auto reset when the Reset Delay reaches zero</p> <p>Off: The trip will not auto reset</p>
Operation5	<p>Allows the user to select whether the unit will auto reset if a Operation5 Trip occurs</p> <p>On: The trip will auto reset when the Reset Delay reaches zero</p> <p>Off: The trip will not auto reset</p>
Operation6	<p>Allows the user to select whether the unit will auto reset if a Operation6 Trip occurs</p> <p>On: The trip will auto reset when the Reset Delay reaches zero</p> <p>Off: The trip will not auto reset</p>
Operation7	<p>Allows the user to select whether the unit will auto reset if a Operation7 Trip occurs</p> <p>On: The trip will auto reset when the Reset Delay reaches zero</p> <p>Off: The trip will not auto reset</p>
Operation8	<p>Allows the user to select whether the unit will auto reset if a Operation8 Trip occurs</p> <p>On: The trip will auto reset when the Reset Delay reaches zero</p> <p>Off: The trip will not auto reset</p>

Auto Reset Function (continued)

Operation9	<p>Allows the user to select whether the unit will auto reset if a Operation9 Trip occurs</p> <p>On: The trip will auto reset when the Reset Delay reaches zero</p> <p>Off: The trip will not auto reset</p>
Overload	<p>Allows the user to select whether the unit will auto reset if a Overload Trip occurs</p> <p>On: The trip will auto reset when the Reset Delay reaches zero</p> <p>Off: The trip will not auto reset</p>
Ph/SCR	<p>Allows the user to select whether the unit will auto reset if a Ph/SCR Trip occurs</p> <p>On: The trip will auto reset when the Reset Delay reaches zero</p> <p>Off: The trip will not auto reset</p>
Phase Loss	<p>Allows the user to select whether the unit will auto reset if a Phase Loss Trip occurs</p> <p>On: The trip will auto reset when the Reset Delay reaches zero</p> <p>Off: The trip will not auto reset</p>
Relay 13 14	<p>Allows the n/c relay (13 -14) to be reconfigured</p> <p>Available options are End Of Start or Fault or Run or Pending or Exceeded</p>
Remote	<p>Allows the user to select whether the unit will auto reset if a Remote Trip occurs</p> <p>On: The trip will auto reset when the Reset Delay reaches zero</p> <p>Off: The trip will not auto reset</p>

Auto Reset Function (continued)

Reset Attempts	<p>The number of restart attempts allowed before the Auto Reset terminates. If the Auto Reset has been successful, the counter is reset back to its maximum value when the unit has been running fault free for the Trip Free Time</p> <p>If the Auto Restart has been unsuccessful the counters are re-initialised by applying a reset signal or removing the start signal. If this PNU is set to zero at any point the Auto Reset feature will terminate and the counters will be re-initialised</p> <p>The number of attempts remaining can be viewed in the Monitor menu</p>
Reset Delay	<p>The delay between the trip event and the automatic reset, the unit will re-start following the reset if the start signal is active</p> <p>If this is set to zero at any point the Auto Reset feature will terminate and the counters will be re-initialised</p> <p>When the delay is active the Restart Pending parameter is set and the time remaining can be viewed in the monitor menu</p>
Rotation	<p>Allows the user to select whether the unit will auto reset if a Rotation Trip occurs</p> <p>On: The trip will auto reset when the Reset Delay reaches zero</p> <p>Off: The trip will not auto reset</p>
ScrFire	<p>Allows the user to select whether the unit will auto reset if a ScrFire Trip occurs</p> <p>On: The trip will auto reset when the Reset Delay reaches zero</p> <p>Off: The trip will not auto reset</p>
SCRSen	<p>Allows the user to select whether the unit will auto reset if a SCRSen Trip occurs</p> <p>On: The trip will auto reset when the Reset Delay reaches zero</p> <p>Off: The trip will not auto reset</p>

Auto Reset Function (continued)

Shearpin	<p>Allows the user to select whether the unit will auto reset if a Shearpin Trip occurs</p> <p>On: The trip will auto reset when the Reset Delay reaches zero</p> <p>Off: The trip will not auto reset</p>
Thermal	<p>Allows the user to select whether the unit will auto reset if a Thermal Trip occurs</p> <p>On: The trip will auto reset when the Reset Delay reaches zero</p> <p>Off: The trip will not auto reset</p>
Trip Free Time	<p>The time the unit must be run trip free before the counters are re-initialised back to zero</p> <p>If this PNU is set to zero at any point the Auto Reset feature will terminate and the counters will be re-initialised</p> <p>The Trip Free Time can be viewed in the Monitor menu</p>
UcLow	<p>Allows the user to select whether the unit will auto reset if a UcLow Trip occurs</p> <p>On: The trip will auto reset when the Reset Delay reaches zero</p> <p>Off: The trip will not auto reset</p>

Auto Reset Function (continued)

Two-Wire, Three-Wire and Communications Control

(Control Supply maintained)

The Auto reset operates with two-wire, three-Wire and communications start/stop.

In Two-Wire the motor will not start if the start signal is low, however in 3-wire and communications control the motor may start without a direct start signal (although it is implied as no stop had been given during the reset delay period).

Control Supply Loss

When the control supply is removed the microcontroller is unable to make calculations in real time. To overcome this the calculations are made retrospectively when the starter powers up.

Two Wire: Following a control supply loss the Start signal must be retained (Fig 2).

Three Wire: The state of the start signal is saved when the control supply is removed and if it was set to 'start' the Auto Reset will continue at power up. When operating in this mode the motor may start at power up without a start signal being present (Fig 3).

Modbus/Communications: The state of the start signal is saved when the control supply is removed and if it was set to 'start' the Auto Reset will continue at power up. When operating in this mode the motor may start at power up without a start signal being present (Fig 3).

Auto Restart Termination: If the time to re-establish the power exceeds the Reset Delay x Reset Attempts the Auto Reset Terminates.

Overload Trip

Following an overload trip (1301) the overload % will be at 100% and then cool exponentially to 0% after several minutes. If a re-start is attempted too soon the starter will trip again as the overload % would not have cooled to a sufficient level (Fig 5).

It must be ensured the Reset Delay is long enough to allow the overload to cool. This is also the case for the heatsink over temperature trip.

Remote Start on Trip

If Auto Reset is turned on some of the Remote Start On trips are disabled and will be ignored.

Auto Reset Function (continued)

Fig 1 : Auto Reset - Two Wire -Three Phase Supply Loss

The timing diagrams show the auto reset with a maintained two wire control system
 The fault shown is a 3-phase supply loss only, the Control Supply maintained
 The 3-Phase power is re-established (after the 2nd attempt) before the Reset Attempts counter is depleted
 This assumes the start signal is maintained, if it is removed the Auto Reset terminates
 Once power has been re-established there are no further outages and the counters are reset after the trip free time.

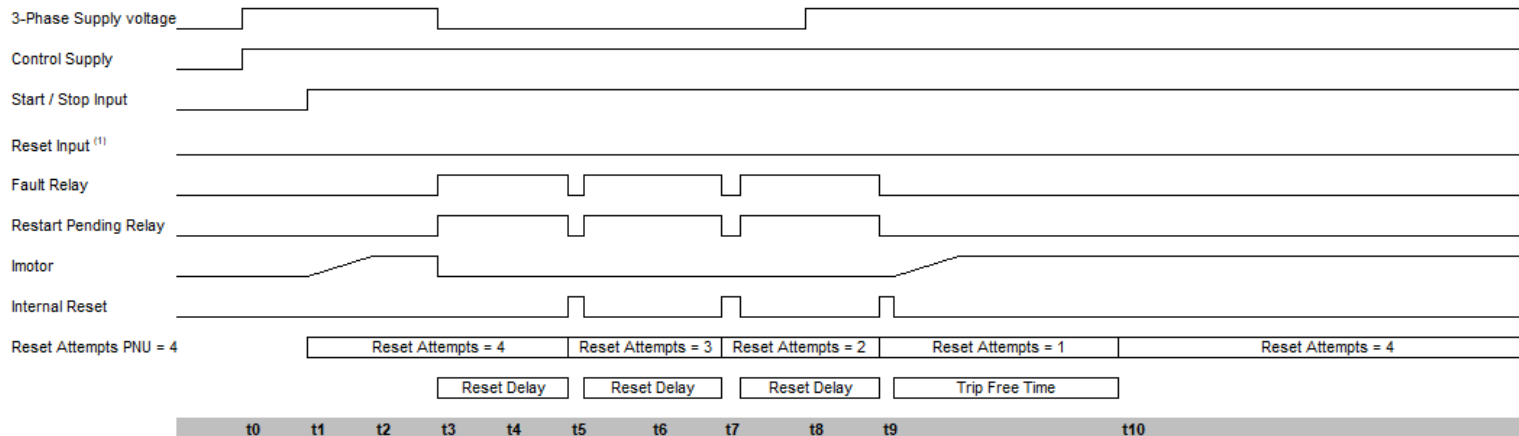

Sequence of events	
t0	3 phase supply applied
t1	Start signal applied, motor starts
t2	Motor reaches full voltage
t3	3 phase supply removed
t4	Start signal must still be applied If it has been removed Auto Reset feature re-initialises
t5	Reset delay = 0 Restart Attempt = 3
t6	Rest Signal must be low If the trip is reset the Auto Reset feature re-initialises
t7	Reset delay = 0 Restart Attempt = 2
t8	3-Phase re-established
t9	Reset delay = 0 Restart Attempt = 1
t10	Trip Free Delay = 0 Restart Attempt = 4

User Parameters (R/W)		
PNU	Range	Default
Auto Reset	Off / On	Off
Reset Delay	0-7200s	0s
Reset Attempts	0-10	0
Reset Trips	All resettable trips	-
Trip Free Time	0-7200s	600s

Monitor Parameters (R/O)	
PNU	Range
Auto Reset Pending	0-1
Auto Reset Exceeded	0-1
Auto Reset Delay Remaining	0-7200s
Auto Reset Attempts Remaining	0-10
Auto Reset Trip Free Time Remaining	0-7200s

Notes
 For Two Wire control reset occurs automatically when the start signal changes state from low to high, reset shown is programmable reset input ⁽¹⁾

Auto Reset Function (continued)

Fig 2 : Auto Reset - Two Wire - Control Supply Loss

The timing diagrams show the auto reset with a maintained two wire control system
 The fault shown is a 3-phase supply loss and Control supply loss
 The 3-Phase power and control supply are re-established (after the 2nd attempt) before the Reset Attempts counter is depleted
 This assumes the start signal is maintained, if it is removed the Auto Reset terminates
 Once power has been re-established there are no further outages and the counters are reset after the trip free time.

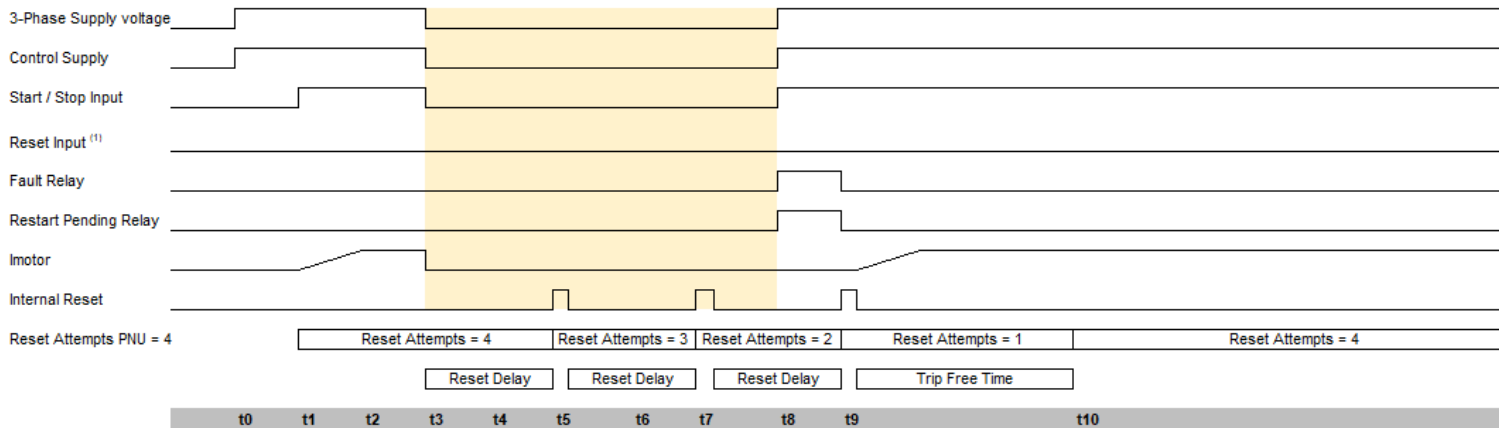

Sequence of events	
t0	3 phase supply applied
t1	Start signal applied, motor starts
t2	Motor reaches full voltage
t3	3 phase supply removed
t5	Reset delay = 0 Restart Attempt = 3
t7	Reset delay = 0 Restart Attempt = 2
t8	3-Phase re-established Start signal must still be applied If it has been removed Auto Reset feature re-initialises If the trip is reset the Auto Reset feature re-initialises
t9	Reset delay = 0 Restart Attempt = 1
t10	Trip Free Delay = 0 Restart Attempt = 4

User Parameters (R/W)		
PNU	Range	Default
Auto Reset	Off / On	Off
Reset Delay	0-7200s	0s
Reset Attempts	0-10	0
Reset Trips	All resettable trips-	-
Trip Free Time	0-7200s	600s

Monitor Parameters (R/O)	
PNU	Range
Auto Reset Pending	0-1
Auto Reset Exceeded	0-1
Auto Reset Delay Remaining	0-7200s
Auto Reset Attempts Remaining	0-10
Auto Reset Trip Free Time Remaining	0-7200s

Notes
 The Starter is powered down between t3 and t8 (yellow shaded region)
 During this time controller is unable to make the calculations in real time
 To overcome this the calculations are made retrospectively at time t8
 The Start Signal must be maintained, if it is not the Auto Restart will be terminated
 For Two Wire control reset occurs automatically when the start signal changes state from low to high, reset shown is programmable reset input⁽¹⁾
 If the time to re-establish the power exceeds (Reset Delay x Reset Attempts) to Auto Reset terminates

Auto Reset Function (continued)

Fig 3 : Auto Reset - Three Wire - Three Phase Supply Loss

The timing diagrams show the auto reset with Three wire / Modbus control
 The fault shown is a 3-phase supply loss only, the Control Supply maintained
 The 3-Phase power is re-established (after the 2nd attempt) before the Reset Attempts counter is depleted
 This assumes the momentary stop signal is not activated, if it is the Auto Reset terminates
 Once power has been re-established there are no further outages and the counters are reset after the trip free time.

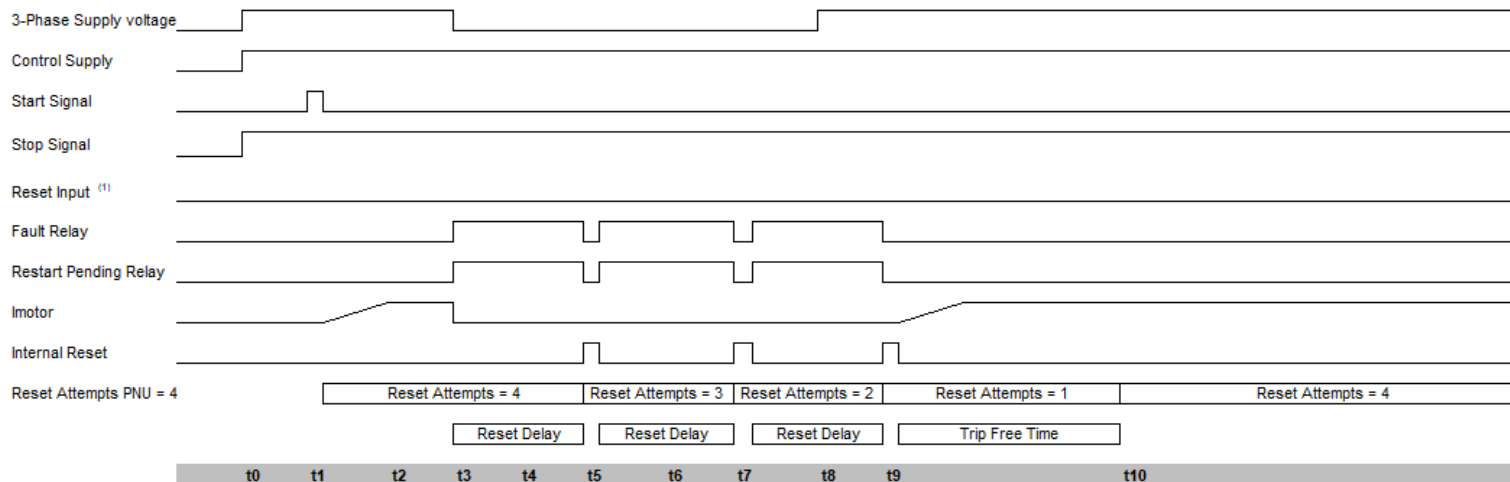

Sequence of events	
t0	3 phase supply applied
t1	Start signal applied, motor starts
t2	Motor reaches full voltage
t3	3 phase supply removed
t4	Start signal must still be applied If it has been removed Auto Reset feature re-initialises
t5	Reset delay = 0 Restart Attempt =3
t6	Reset Signal must be low If the trip is reset the Auto Reset feature re-initialises
t7	Reset delay = 0 Restart Attempt =2
t8	3-Phase re-established
t9	Reset delay = 0 Restart Attempts =1
t10	Trip Free Delay = 0 Restart Attempts =4

User Parameters (R/W)		
PNU	Range	Default
Auto Reset	Off / On	Off
Reset Delay	0-7200s	0s
Reset Attempts	0-10	0
Reset Trips	All resettable trips -	
Trip Free Time	0-7200s	600s

Monitor Parameters (R/O)	
PNU	Range
Auto Reset Pending	0-1
Auto Reset Exceeded	0-1
Auto Reset Delay Remaining	0-7200s
Auto Reset Attempts Remaining	0-10
Auto Reset Trip Free Time Remaining	0-7200s

Notes
 (1) Seperate reset signal not avialbe on all products

Auto Reset Function (continued)

Fig 4 : Auto Reset - Three Wire - Control Supply Loss

The timing diagrams show the auto reset with Three wire / Modbus control
 The fault shown is a 3-phase supply loss and Control supply loss
 The 3-Phase power and control supply are re-established (after the 2nd attempt) before the Reset Attempts counter is depleted
 This assumes the momentary stop signal is not activated, if it is the Auto Reset terminates
 Once power has been re-established there are no further outages and the counters are reset after the trip free time.

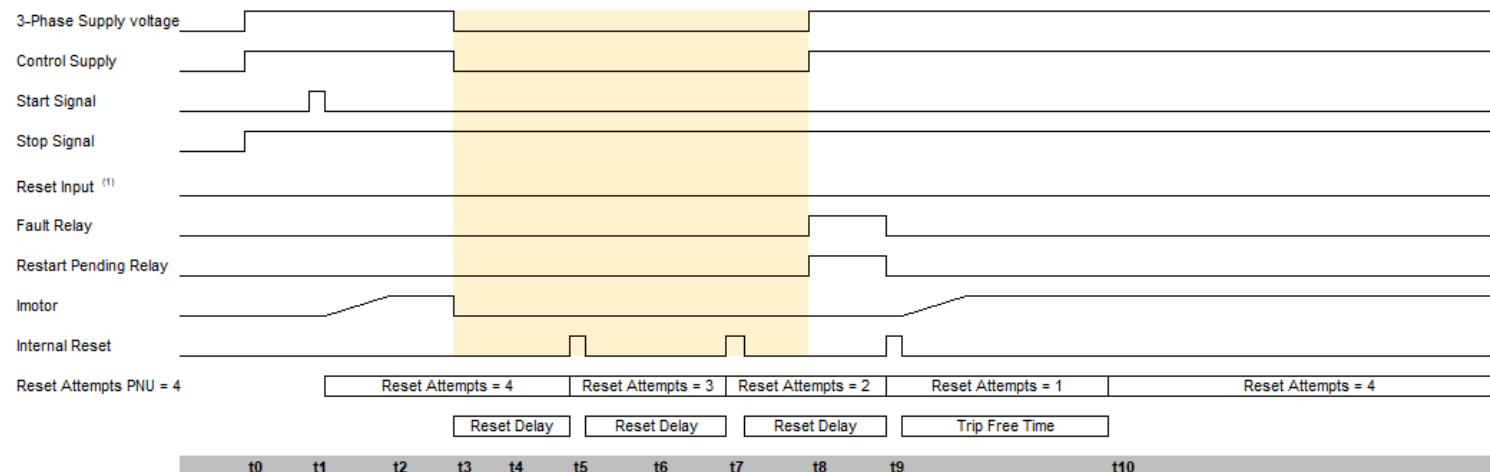

Sequence of events	
t0	3 phase supply applied
t1	Start signal applied, motor starts
t2	Motor reaches full voltage
t3	3 phase supply removed
t5	Reset delay = 0 Restart Attempts = 3
t7	Reset delay = 0 Restart Attempts = 2
t8	3-Phase re-established
	Start signal must still be applied
	If it has been removed Auto Reset feature re-initialises
	Rest Signal must be low
	If the trip is reset the Auto Reset feature re-initialises
t9	Reset delay = 0 Restart Attempts = 1
t10	Trip Free Delay = 0 Restart Attempts = 4

User Parameters (R/W)		
PNU	Range	Default
Auto Reset	Off / On	Off
Reset Delay	0-7200s	0s
Reset Attempts	0-10	0
Reset Trips	All resettable trips	-
Trip Free Time	0-7200s	600s

Monitor Parameters (R/O)	
PNU	Range
Auto Reset Pending	0-1
Auto Reset Exceeded	0-1
Auto Reset Delay Remaining	0-7200s
Auto Reset Attempts Remaining	0-10
Auto Reset Trip Free Time Remaining	0-7200s

Notes
 The controller is powered down between t3 and t8 (yellow shaded region)
 During this time controller is unable to make the calculations in real time
 To overcome this the calculations are made retrospectively at time t8
 Start signal state saved at power down and loaded at power up. **This means it will start without a start signal being present**
 If the time to re-establish the power exceeds (Reset Delay x Reset Attempts) to Auto Reset terminates
 (1) Seperate reset signal not avialbe on all products

Auto Reset Function (continued)

Fig 5 : Auto Reset - Two Wire - Overload

The timing diagrams show the auto reset with a maintained two wire control system
 The fault shown is an overload trip, the Control Supply maintained
 In this instance the Auto Reset clears the trip but the overload (%) will take a certain amount of time to decay
 If insufficient time is left before re-starts the overload will trip again repeatedly until the Reset Attempts count exceeds its set value.
 This must be considered and enough time left to allow the overload to decay to a low level

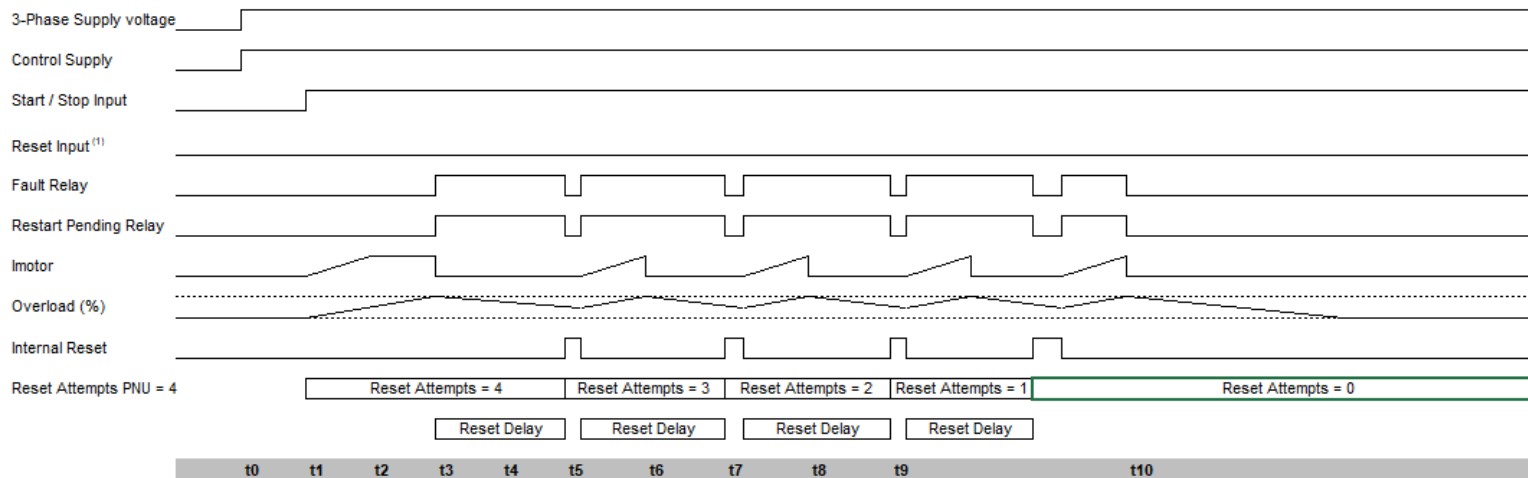

Sequence of events	
t0	3 phase supply applied
t1	Start signal applied, motor starts
t2	Motor reaches full voltage
t3	3 phase supply removed
t4	Start signal must still be applied If it has been removed Auto Reset feature re-initialises
t5	Reset delay = 0 Restart Attempts = 3
t6	Reset Signal must be low If the trip is reset the Auto Reset feature re-initialises
t7	Reset delay = 0 Restart Attempts = 2
t8	3-Phase re-established
t9	Reset delay = 0 Restart Attempts = 1
t10	Trip Free Delay = 0 Restart Attempts = 0

User Parameters (RW)		
PNU	Range	Default
Auto Reset	Off / On	Off
Reset Delay	0-7200s	0s
Reset Attempts	0-10	0
Reset Trips	All resettable trips	-
Trip Free Time	0-7200s	600s

Monitor Parameters (R/O)	
PNU	Range
Auto Reset Pending	0-1
Auto Reset Exceeded	0-1
Auto Reset Delay Remaining	0-7200s
Auto Reset Attempts Remaining	0-10
Auto Reset Trip Free Time Remaining	0-7200s

Notes
 In this instance the starter has failed to Auto Restart in the set number of attempts
 The starter will remain in the tripped state until reset
 To overcome this the Reset Delay time should be extended to allow the overload to cool
 For Two Wire control reset occurs automatically when the start signal changes state from low to high, reset shown is programmable reset input⁽¹⁾

Communication

Modbus RTU Serial Communications

Modbus RTU Communications Interface

All VMX-agility™ soft starts support Modbus RTU as standard. The RS-485 communications are accessible from the RJ45 connector (see below).

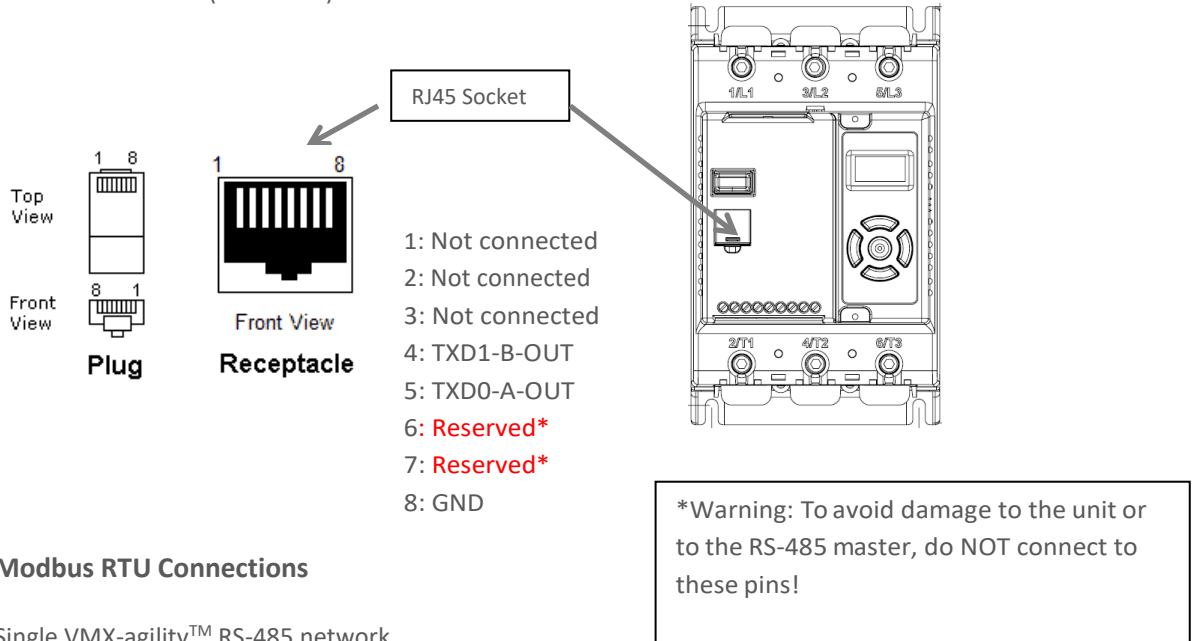

Modbus RTU Connections

Single VMX-agility™ RS-485 network

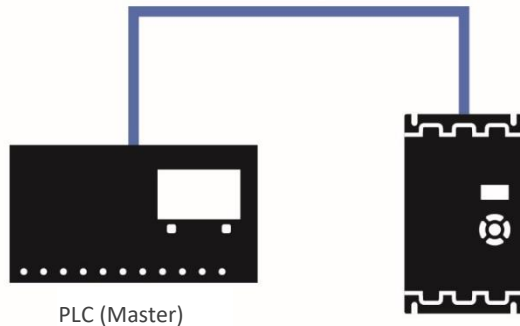

Multiple VMX-agility™ RS-485 network

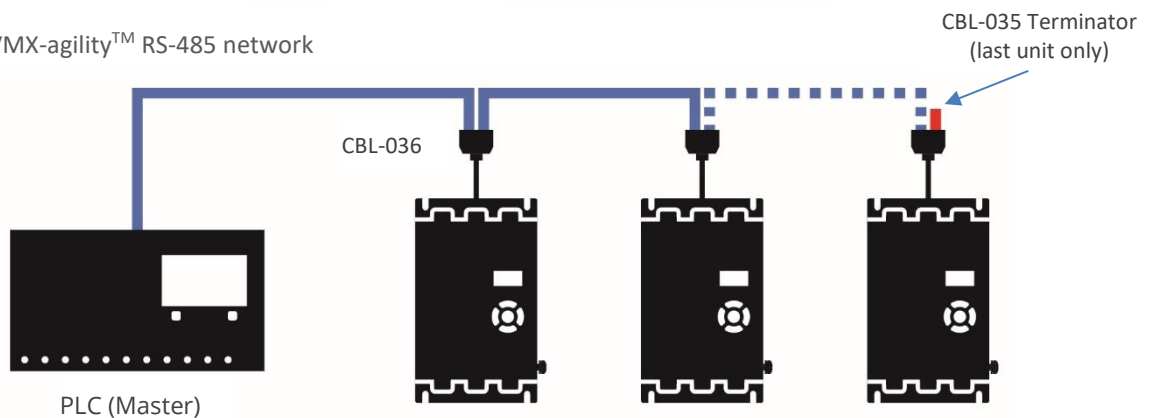

The VMX-agility™ units must have: a unique Modbus address on each unit and identical Parity/Baud rate values on each unit

Communication (continued)

Modbus Communications Configuration

The Modbus communication settings may be configured from the Device menu:

Device >> Networks >> Modbus Network Settings >> Address (1 –32)

Device >> Networks >> Modbus Network Settings >> Baud (9600 –115200)

Device >> Networks >> Modbus Network Settings >> Parity (Odd /Even)

(Data bits = 8, Stop bits = 1)

The communication parameters should be set before connecting the Modbus master.

Transmission Modes

ASCII and RTU transmission modes are defined in the Modbus protocol specification. VMX-agility™ uses *only the RTU mode* for the message transmission.

Message Structure For RTU Mode

The Modbus RTU structure uses a master-slave system for message exchange. In the case of the VMX-agility™ system, it allows up to 32 slaves, and one master. Every message begins with the master making a request to a slave, which responds to the master in a defined structure. In both messages (request and answer), the used structure is the same:

- Address, Function Code, Data and CRC

Master (request message):

Address (1 byte)	Function (1 byte)	Request Data (n bytes)	CRC (2 bytes)
---------------------	----------------------	---------------------------	------------------

Slave (response message):

Address (1 byte)	Function (1 byte)	Response Data (n bytes)	CRC (2 bytes)
---------------------	----------------------	----------------------------	------------------

Address

The master initiates the communication by sending a byte with the address of the destination slave. When responding, the slave also initiates the message with its own address. Broadcast to address 0 (zero) is not supported.

Function Code

This field contains a single byte, where the master specifies the type of service or function requested to the slave (reading, writing, etc.). According to the protocol, each function is used to access a specific type of data.

Data Field

The format and contents of this field depend on the function used and the transmitted value.

Communication (continued)

CRC

The used method is the CRC-16 (Cyclic Redundancy Check). This field is formed by two bytes; where first the least significant byte is transmitted (CRC-), and then the most significant (CRC+). The CRC calculation form is described in the Modbus RTU protocol specification.

Supported Functions

Modbus RTU specification defines the functions used to access different types of data.

VMX-agility™ parameters are defined as holding type registers.

For Modbus RTU/TCP Client devices that use Modicon style addressing, place a 4 as the high digit followed by the Modbus address defined in the parameter mapping table. Note that VMX-agility™ Modbus addressing starts at zero; not 1 as some devices do.

VMX-agility™ 32-bit parameters are High Word/Low Word in Modbus format.

The following services are available:

Read Holding Registers

Description: reading register blocks of holding register type (block R/W limited to 8 registers).

- Function code: 03 example

Modbus Function 03 Transaction Table			
Query		Response	
Field	Hex Byte	Field	Hex Byte
Slave address	01	Slave address	01
Function	03	Function	03
Start address Hi	00	Byte count	02
Start address Lo	01	Data Hi	01
No of registers Hi	00	Data Lo	2C
No of registers Lo	01	CRC Lo	B8
CRC Lo	D5	CRC Hi	09
CRC Hi	CA		

Communication (continued)

Write Single Register

Description: writing in a single register of the holding type.

- Function code: 06 example

Modbus Function 06 Transaction Table			
Query		Response	
Field	Hex Byte	Field	Hex Byte
Slave address	01	Slave address	01
Function	06	Function	06
Address Hi	00	Address Hi	02
Address Lo	0C	Address Lo	0C
Data Hi	00	Data Hi	00
Data Lo	09	Data Lo	09
CRC Lo	48	CRC Lo	88
CRC Hi	0C	CRC Hi	77

Write Multiple Registers

Description: writing register blocks of holding register type (block R/W limited to 8 registers).

Function code: 16 example

Modbus Function 16 Transaction Table			
Query		Response	
Field	Hex Byte	Field	Hex Byte
Slave address	01	Slave address	01
Function	10	Function	10
Address Hi	00	Address Hi	00
Address Lo	01	Address Lo	01
# Words Hi	00	# Words Hi	00
# Words Lo	01	# Words Lo	01
# Bytes	02	CRC Lo	50
Data Hi	00	CRC Hi	09
Data Lo	02		
CRC Lo	26		
CRC Hi	40		

Modbus RTU Parameters

Memory Map

VMX-agility™ Modbus communication is based on reading or writing equipment parameters from or to the holding registers. The data addressing is zero offset, such that the parameter Modbus address corresponds to the register number.

Modbus Address Memory Map		
Parameter Modbus Address	Modbus Data Address	
	Decimal	Hex
0000	0	0000h
0001	1	0001h
•	•	•
•	•	•
•	•	•
•	•	•
0128	128	0080h
•	•	•
•	•	•
•	•	•

Message Timing

In the RTU mode there is no specific start or stop byte that marks the beginning or the end of a message. Indication of when a new message begins or when it ends is achieved by the absence of data transmission for a minimum period of 3.5 times the transmission time of a data byte. Thus, in case a message is transmitted after this minimum time has elapsed; the network elements will assume that the first received character represents the beginning of a new message.

Modbus RTU Parameters (continued)

PNU	Name	Description	Options	Words	Type	Units	Detail
1	Cntrl Mode	<p>Selects the method for starting and controlling the motor</p> <p>Local: Control using the button on the keypad</p> <p>Remote: Control using the terminals</p> <p>Modbus: Control via Modbus network</p>	0=Local, 1=Remote, 2=Modbus.	1	R/W		Multiplier: 1 Divisor: 1 Offset: 0 Min: 0 Max: 2 Default: 0
2	Initial Volts	<p>Percentage of the supply voltage applied to motor at the beginning of the soft start</p> <p>Increase to provide more torque if the load fails to break away</p> <p>Decrease if the motor accelerates too quickly</p>		1	R/W	%	Multiplier: 100 Divisor: 16384 Offset: 0 Min: 1638 Max: 13107 Default: 3277
4	Start Time	<p>Time taken to soft start from the "Initial Volts" to the end of the start</p> <p>Normally set between 5 and 30 seconds</p> <p>Actual time to get to full voltage depends on the "Limit Amps"</p> <p>If set too long the motor can be at speed before the end of the time set</p>		1	R/W	s	Multiplier: 1 Divisor: 1 Offset: 0 Min: 1 Max: 30 Default: 10
5	Stop Time	<p>The time taken to soft stop from full voltage to the end of the stop</p> <p>Normally set between 15 and 30 seconds</p> <p>Actual time to get to the final voltage depends on the "Limit Amps"</p> <p>If set too long the motor may reach zero speed before the end of the time set</p>		1	R/W	s	Multiplier: 1 Divisor: 1 Offset: 0 Min: 0 Max: 30 Default: 0

Modbus RTU Parameters (continued)

PNU	Name	Description	Options	Words	Type	Units	Detail
6	Start Delay	<p>Time allowed for external contactors to close</p> <p>Increase if contactors are driven by buffer relays or motor trips on phase loss when start signal applied</p> <p>Decrease if response to start signal needs to be improved</p>		1	R/W	ms	Multiplier: 1 Divisor: 1 Offset: 0 Min: 100 Max: 30000 Default: 160
7	Serial No	The device serial number stored at the point of manufacture		4	R		Multiplier: 1 Divisor: 1 Offset: 0 Min: 0 Max: 255 Default: 0
11	Model No	The device Model number stored at the point of manufacture		1	R		Multiplier: 1 Divisor: 1 Offset: 0 Min: 101 Max: 113 Default: 101
14	Version	<p>Software Version for the Main control PCB</p> <p>Software version recorded in log file</p>		2	R		Multiplier: 1 Divisor: 1 Offset: 0 Min: 0 Max: 65535 Default: 0

Modbus RTU Parameters (continued)

PNU	Name	Description	Options	Words	Type	Units	Detail
16	Application	<p>The Unit has numerous pre-set applications built in as standard Select the application best suited to the load</p> <p>The selected application will automatically change several parameters and functions Depending on the application loaded the "Trip Class" may also change</p> <p>Refer to the separate 'applications section' for more details</p>	See Table 1	1	R/W		Multiplier: 1 Divisor: 1 Offset: 0 Min: 0 Max: 23 Default: 0
17	Trip Class	<p>The trip class is a numeric value that correlates the trip time with overload level</p> <p>Select Trip class according to application requirements</p> <p>The trip time depends on the selected "Trip Class" the duration of the overload and the level of the over current</p> <p>Refer to the Motor Overload 'cold' trip curves given in the Guide</p> <p>When "Class 20" or "Class30" are selected the Unit current rating (Unit Amps) will be reduced to a lower value (Rated Amps)</p>	10=Class10, 20=Class20, 30=Class30.	1	R/W		Multiplier: 1 Divisor: 1 Offset: 0 Min: 10 Max: 30 Default: 10
18	Motor Amps	<p>This should be set to the Full Load Current shown on the motor plate</p> <p>The overload works with multiples of the set "Motor Amps"</p> <p>Also referred to as Motor FLA</p>		2	R/W	A	Multiplier: 1 Divisor: 1000 Offset: 0 Min: 0.1 x PNU18 Max: 1 x PNU20 Default: 1 x PNU20

 Modbus RTU Parameters (continued)

PNU	Name	Description	Options	Words	Type	Units	Detail
20	Rated Amps	Unit Class20/Class30 Current Rating		2	R	A	Multiplier: 1 Divisor: 1000 Offset: 0 Min: 17000 Max: 66000 Default: 17000
22	Unit Amps	Unit Class10 Current Rating		2	R	A	Multiplier: 1 Divisor: 1000 Offset: 0 Min: 17000 Max: 66000 Default: 17000
24	MotorState	Indicates the Unit Operating State	See Table 2	1	R		Multiplier: 1 Divisor: 1 Offset: 0 Min: 0 Max: 65535 Default: 0
25	I rms	The RMS motor current The average of the 3 phases This value is used for the current Limit and overload features		2	R	A	Multiplier: 1 Divisor: 1000 Offset: 0 Min: 0 Max: 24 Default: 0

Modbus RTU Parameters (continued)

PNU	Name	Description	Options	Words	Type	Units	Detail
27	Overload	<p>The Unit has an "Overload" function that is an electronic equivalent to a thermal overload</p> <p>Overload displays the overload capacity which is a measure of how close the Unit to tripping on "Overload Trip"</p> <p>When "Irms" is greater than the "Overload Amps" the "Overload" increases in accordance with the "Trip Class"</p> <p>When "Current Irms" is less than "Overload Level" the "Overload" decreases exponentially (if greater than 50%)</p> <p>When the "Overload" reaches 100% the Unit will trip</p> <p>During situations when "Motor Amps" is equal to "Unit Amps" the overload will indicate 50%</p>		1	R	%	Multiplier: 10 Divisor: 16384 Offset: 0 Min: 0 Max: 16384 Default: 0 During situations when "Motor Amps" is equal to "Unit Amps" the overload will indicate 50%
30	Frequency	The frequency of the 3-phase supply		1	R	Hz	Multiplier: 1 Divisor: 1000 Offset: 0 Min: 45000 Max: 65000 Default: 0
31	Factory Rst	Restores the Unit to the factory defaults	0=Idle, 1=Active.	1	R/W		Multiplier: 1 Divisor: 1 Offset: 0 Min: 0 Max: 1 Default: 0

Modbus RTU Parameters (continued)

PNU	Name	Description	Options	Words	Type	Units	Detail
32	Store Param	Saves all Read/Write parameters to non-volatile memory Yes: Parameters are permanently written No: Parameters remain changed until next power cycle	0=Idle, 1=Active.	1	R/W		Multiplier: 1 Divisor: 1 Offset: 0 Min: 0 Max: 1 Default: 0
33	Save Log	Download the full log file on to the USB stick The Unit logs several parameters during normal and fault conditions Data is stored in CSV format. Please send all downloaded files to Motortronics UK on request	0=Idle, 1=Active.	1	R/W		Multiplier: 1 Divisor: 1 Offset: 0 Min: 0 Max: 1 Default: 0
34	Date	Enter current date Date format can be set to either dd/mm/yyyy or mm/dd/yyyy. Refer to "Date format" parameter		1	R/W		Multiplier: 1 Divisor: 1 Offset: 0 Min: 0 Max: 65535 Default: 0
35	Time	Allows the time to be changed to 'local' time By default the time is set to GMT		2	R/W		Multiplier: 1 Divisor: 1 Offset: 0 Min: 0 Max: 65535 Default: 0

Modbus RTU Parameters (continued)

PNU	Name	Description	Options	Words	Type	Units	Detail
37	Rotation	Indicates the phase sequence of the incoming supply RYB = ABC = L1-L2-L3 RBY = ACB = L1-L3-L2	0=-----, 1=L1L2L3, 2=L1L3L2.	1	R		Multiplier: 1 Divisor: 1 Offset: 0 Min: 0 Max: 2 Default: 0
39	HS Temp C	The temperature of the internal Unit heatsink The Unit will trip when the heatsink temperature exceeds 80°C The internal cooling fans will turn on if this temperature exceeds 40°C		1	R	C	Multiplier: 1 Divisor: 16 Offset: 0 Min: 0 Max: 65535 Default: 0
40	HS Temp F	The temperature of the internal Unit heatsink The Unit will trip when the heatsink temperature exceeds 176°C The internal cooling fans will turn on if this temperature exceeds 104°F		1	R	F	Multiplier: 9 Divisor: 80 Offset: 32 Min: 0 Max: 65535 Default: 0
41	I1 rms	The RMS current on phase L1		2	R	A	Multiplier: 1 Divisor: 1000 Offset: 0 Min: 0 Max: 24 Default: 0

Modbus RTU Parameters (continued)

PNU	Name	Description	Options	Words	Type	Units	Detail
43	I2 rms	The RMS current on phase L2		2	R	A	Multiplier: 1 Divisor: 1000 Offset: 0 Min: 0 Max: 24 Default: 0
45	I3 rms	The RMS current on phase L3		2	R	A	Multiplier: 1 Divisor: 1000 Offset: 0 Min: 0 Max: 24 Default: 0
47	Delay Angle	Internal firing delay angle in Degrees Displayed for diagnostic purposes		1	R	°	Multiplier: 1 Divisor: 1 Offset: 0 Min: 0 Max: 180 Default: 0
48	AGY100 Ver	The hardware version for display PCB		1	R		Multiplier: 1 Divisor: 1 Offset: 0 Min: 0 Max: 65535 Default: 1

Modbus RTU Parameters (continued)

PNU	Name	Description	Options	Words	Type	Units	Detail
49	Phase Loss	<p>Detects for various issues when the start signal is applied</p> <p>Detects for input phase loss/input phase relationship/motor side loss</p> <p>Trip On: Trips if there is an input phase loss/supply out of balance/ motor side loss</p> <p>Trip Off: The Unit will attempt to run although the operation may be erratic</p> <p>Operating with the Trip Off for prolonged periods may result in SCR failure</p>	0=Trip Off, 1=Trip On.	1	R/W		Multiplier: 1 Divisor: 1 Offset: 0 Min: 0 Max: 1 Default: 1
50	Overheat	<p>Detects if the internal temperature sensor has malfunctioned</p> <p>Trip On: The Unit will trip if the internal temperature sensor malfunctions</p> <p>Trip Off: The Unit will continue to operate even if the temperature sensor has malfunctioned</p> <p>Operating with the Trip Off for prolonged periods may result in SCR failure</p>	0=Trip Off, 1=Trip On.	1	R/W		Multiplier: 1 Divisor: 1 Offset: 0 Min: 0 Max: 1 Default: 1
51	Ph/SCR	<p>Detects for various issues when "Starting" or " Stopping"</p> <p>Detects for input phase loss/output phase loss/SCR misfire</p> <p>Trip On: Trips if there is an input phase loss/motor side phase loss/ SCR misfire</p> <p>Trip Off: The Unit will attempt to run although the operation may be erratic</p> <p>Operating with the Trip Off for prolonged periods may result in SCR failure</p>	0=Trip Off, 1=Trip On.	1	R/W		Multiplier: 1 Divisor: 1 Offset: 0 Min: 0 Max: 1 Default: 1

Modbus RTU Parameters (continued)

PNU	Name	Description	Options	Words	Type	Units	Detail
58	I Low	This can be used to detect if the motor is running lightly loaded Trip On: The Unit will trip. This feature is not active during soft start and soft stop Trip Off: The Unit will continue to operate regardless of motor current	0=Trip Off, 1=Trip On.	1	R/W		Multiplier: 1 Divisor: 1 Offset: 0 Min: 0 Max: 1 Default: 0
59	I Limit Start	Selects trip or continue if the current limit has been active for too long Trip On: The Unit will trip Trip Off: The start will continue regardless of the motor current level	0=Trip Off, 1=Trip On.	1	R/W		Multiplier: 1 Divisor: 1 Offset: 0 Min: 0 Max: 1 Default: 1
60	Overload	The Unit has an "Overload" function that is an electronic equivalent to a thermal overload Trip On: The Unit will trip when the "Overload" capacity (Modbus PNU 27) exceeds 100% Trip Off: The Unit will continue to operate regardless of motor current level	0=Trip Off, 1=Trip On.	1	R/W		Multiplier: 1 Divisor: 1 Offset: 0 Min: 0 Max: 1 Default: 1
61	Shearpin	The Shearpin is an electronic equivalent of a mechanical Shearpin Trip On: The Unit will trip. This feature is not active during soft start and soft stop Trip Off: The Unit will continue to operate regardless of motor current level	0=Trip Off, 1=Trip On.	1	R/W		Multiplier: 1 Divisor: 1 Offset: 0 Min: 0 Max: 1 Default: 1

Modbus RTU Parameters (continued)

PNU	Name	Description	Options	Words	Type	Units	Detail
64	Comms	<p>Detects if the communications bus has failed or become inactive</p> <p>To keep the bus active there must be at least one Modbus read or write (any PNU) during the "Comms Time" period (ModbusPNU 147)</p> <p>Trip On: Communication trip enabled</p> <p>Trip Off: External Trip is disabled</p>	0=Trip Off, 1=Trip On.	1	R/W		Multiplier: 1 Divisor: 1 Offset: 0 Min: 0 Max: 1 Default: 1
66	Remote	<p>For safety reasons the Unit will trip during some operations if the remote start signal is active</p> <p>Trip On: Trips if the remote start signal is active when the Unit is powered up or a reset is applied</p> <p>Trip Off: The Unit will not trip and may start unexpectedly if the start signal is accidentally left active</p>	0=Trip Off, 1=Trip On.	1	R/W		Multiplier: 1 Divisor: 1 Offset: 0 Min: 0 Max: 1 Default: 1
67	CT Fault	<p>Detects if the internal current sensors have failed or reading a very low level</p> <p>Trip On: The Unit will trip if the internal current sensors fail or the current measured falls to a very low level</p> <p>Trip Off: Will continue to operate even if the sensor has failed. Measurements and overload protection may be affected</p>	0=Trip Off, 1=Trip On.	1	R/W		Multiplier: 1 Divisor: 1 Offset: 0 Min: 0 Max: 1 Default: 1
68	Operation 1	<p>Detects if the Control Board has failed to operate normally</p> <p>Trip On: System Trip enabled</p> <p>Trip Off: System Trip disabled</p>	0=Trip Off, 1=Trip On.	1	R/W		Multiplier: 1 Divisor: 1 Offset: 0 Min: 0 Max: 1 Default: 1

Modbus RTU Parameters (continued)

PNU	Name	Description	Options	Words	Type	Units	Detail
69	Limit Amps	<p>The current in Amps at which the soft Start ramp is held</p> <p>Normally set to 350% of motor FLC</p> <p>Increase if motor fails to accelerate at required rate</p> <p>The "Limit Amps" will affect actual time to start</p> <p>If set too low the motor may not accelerate to full speed</p>		2	R/W	A	Multiplier: 1 Divisor: 1000 Offset: 0 Min: 0.5 x PNU18 Max: 5 x PNU20 Default: 3.5 x PNU20
71	Limit Time	<p>The maximum time allowed for the current limit</p> <p>If the current limit is still active at the end of this period the Unit will either 'Trip' or 'continue'</p>		1	R/W	s	Multiplier: 1 Divisor: 1 Offset: 0 Min: 1 Max: 60 Default: 30
72	Boot Ver	Software Version for the Bootloader		2	R		Multiplier: 1 Divisor: 1 Offset: 0 Min: 0 Max: 65535 Default: 0
74	Cntrl Funct	<p>Allows the Digital inputs to be mapped to different functions Cntrl Mode must be set to "Remote"</p> <p>Two Wire: D1 = Start (Reset) / Stop</p> <p>Three Wire: D1 = Start (Reset) D2 = Stop</p> <p>D2 Reset, D2 Hold, D2 Enable, D2 Fire: D1= Start /Stop, D2 programmed as shown</p>	0=Three Wire, 1=Two Wire, 2=D2 Reset, 3=D2 Hold, 4=D2 Enable, 5=D2 Fire.	1	R/W		Multiplier: 1 Divisor: 1 Offset: 0 Min: 0 Max: 5 Default: 0

Modbus RTU Parameters (continued)

PNU	Name	Description	Options	Words	Type	Units	Detail
75	Op Mode	Allows the unit to operate with a single phase motor 3 phase: Set to control a three phase motor 1 Phase: Set to control a single phase motor	0=3 phase, 1=1 phase.	1	R/W		Multiplier: 1 Divisor: 1 Offset: 0 Min: 0 Max: 1 Default: 0
77	Trip 0	Displays the last Fault trip	See Table 3	1	R		Multiplier: 1 Divisor: 1 Offset: 0 Min: 0 Max: 65535 Default: 0
78	Trip 1	Displays the last Fault trip -1	See Table 3	1	R		Multiplier: 1 Divisor: 1 Offset: 0 Min: 0 Max: 65535 Default: 0
79	Trip 2	Displays the last Fault trip -2	See Table 3	1	R		Multiplier: 1 Divisor: 1 Offset: 0 Min: 0 Max: 65535 Default: 0

Modbus RTU Parameters (continued)

PNU	Name	Description	Options	Words	Type	Units	Detail
80	Trip 3	Displays the last Fault trip -3	See Table 3	1	R		Multiplier: 1 Divisor: 1 Offset: 0 Min: 0 Max: 65535 Default: 0
81	Trip 4	Displays the last Fault trip -4	See Table 3	1	R		Multiplier: 1 Divisor: 1 Offset: 0 Min: 0 Max: 65535 Default: 0
82	Trip 5	Displays the last Fault trip -5	See Table 3	1	R		Multiplier: 1 Divisor: 1 Offset: 0 Min: 0 Max: 65535 Default: 0
83	Trip 6	Displays the last Fault trip -6	See Table 3	1	R		Multiplier: 1 Divisor: 1 Offset: 0 Min: 0 Max: 65535 Default: 0

Modbus RTU Parameters (continued)

PNU	Name	Description	Options	Words	Type	Units	Detail
84	Trip 7	Displays the last Fault trip -7	See Table 3	1	R		Multiplier: 1 Divisor: 1 Offset: 0 Min: 0 Max: 65535 Default: 0
85	Trip 8	Displays the last Fault trip -8	See Table 3	1	R		Multiplier: 1 Divisor: 1 Offset: 0 Min: 0 Max: 65535 Default: 0
86	MenuBuild	Menu Version		1	R		Multiplier: 1 Divisor: 1 Offset: 0 Min: 0 Max: 65535 Default: 0
87	Kick Level	Percentage of the supply voltage applied to the motor during the 'kick' period Increase to provide more torque if the load fails to break away Decrease if the motor accelerates too quickly		1	R/W	%	Multiplier: 100 Divisor: 16384 Offset: 0 Min: 3277 Max: 13107 Default: 9830

Modbus RTU Parameters (continued)

PNU	Name	Description	Options	Words	Type	Units	Detail
88	Kick Time	Time that the torque pulse is applied to load Increase to provide more torque if the load fails to break away Decrease if the motor accelerates too quickly		1	R/W	ms	Multiplier: 1 Divisor: 1 Offset: 0 Min: 100 Max: 2000 Default: 100
89	Kick Start	Applies a short duration torque pulse to dislodge 'sticky' loads On: The torque pulse is applied at start-up when complete the torque drops to the "Initial Volts" Off: The initial starting torque is defined by the "Initial Volts"	0=Off, 1=On.	1	R/W		Multiplier: 1 Divisor: 1 Offset: 0 Min: 0 Max: 1 Default: 0
90	To USB	Allows the user to save parameters Downloads the parameters from the Unit to the USB drive Data is stored in CSV format	0=Idle, 1=Active.	1	R/W		Multiplier: 1 Divisor: 1 Offset: 0 Min: 0 Max: 1 Default: 0
91	From USB	Allows the user to load parameters stored on a USB flash drive Uploads the parameters from the USB drive to the Unit Data is stored in CSV format	0=Idle, 1=Active.	1	R/W		Multiplier: 1 Divisor: 1 Offset: 0 Min: 0 Max: 1 Default: 0

Modbus RTU Parameters (continued)

PNU	Name	Description	Options	Words	Type	Units	Detail
94	I Start	Displays the peak current during the last start		1	R	A	Multiplier: 1 Divisor: 1 Offset: 0 Min: 0 Max: 528 Default: 0
95	T Start	Displays the time of the last start		1	R	s	Multiplier: 1 Divisor: 1 Offset: 0 Min: 0 Max: 90 Default: 0
96	I Stop	Displays the peak current during the last stop		1	R	A	Multiplier: 1 Divisor: 1 Offset: 0 Min: 0 Max: 528 Default: 0
97	T Stop	Displays the time of the last stop		1	R	s	Multiplier: 1 Divisor: 1 Offset: 0 Min: 0 Max: 90 Default: 0

Modbus RTU Parameters (continued)

PNU	Name	Description	Options	Words	Type	Units	Detail
98	Total Events	The total number of events that have been recorded in the log file		2	R		Multiplier: 1 Divisor: 1 Offset: 0 Min: 0 Max: 65535 Default: 0
103	AGY200 Ver	The hardware version for Main PCB		1	R		Multiplier: 1 Divisor: 1 Offset: 0 Min: 0 Max: 65535 Default: 1
104	AGY300 Ver	The hardware version for Power PCB		1	R		Multiplier: 1 Divisor: 1 Offset: 0 Min: 0 Max: 65535 Default: 1
106	Total Uc On	The total number times the start command has been applied		2	R		Multiplier: 1 Divisor: 1 Offset: 0 Min: 0 Max: 65535 Default: 0

Modbus RTU Parameters (continued)

PNU	Name	Description	Options	Words	Type	Units	Detail
109	Operation 2	<p>Detects if the Control Board has failed to operate normally</p> <p>Trip On: System Trip enabled</p> <p>Trip Off: System Trip disabled</p>	0=Trip Off, 1=Trip On.	1	R/W		Multiplier: 1 Divisor: 1 Offset: 0 Min: 0 Max: 1 Default: 1
110	Reserved	No user function					
114	Shear Amps	<p>The current in Amps that will cause a "Shear Trip"</p> <p>A trip will occur if the motor current is greater than the "Shear Amps" for the "Shear Time"</p>		2	R/W	A	Multiplier: 1 Divisor: 1000 Offset: 0 Min: 1 x PNU18 Max: 5 x PNU22 Default: 3.5 x PNU18
116	Shear Time	<p>The trip time for the Shearpin trip</p> <p>A trip will occur if the motor current is greater than the "Shear Amps" for the "Shear Time"</p>		1	R/W	s	Multiplier: 1 Divisor: 1 Offset: 0 Min: 1 Max: 10 Default: 1

Modbus RTU Parameters (continued)

PNU	Name	Description	Options	Words	Type	Units	Detail
119	Modbus Enable	Enable using Modbus On: The unit is enabled Off: The unit is disabled	0=Off, 1=On.	1	R/W		Multiplier: 1 Divisor: 1 Offset: 0 Min: 0 Max: 1 Default: 0
120	Modbus Start	Start/Stop using Modbus On: Starts the Unit Off: Stops or Soft stops the Unit	0=Off, 1=On.	1	R/W		Multiplier: 1 Divisor: 1 Offset: 0 Min: 0 Max: 1 Default: 0
121	Modbus Reset	Reset using Modbus On: The initial state required for a reset Off: The final state required for a reset To reset pulse high and then low	0=Off, 1=On.	1	R/W		Multiplier: 1 Divisor: 1 Offset: 0 Min: 0 Max: 1 Default: 0
143	Fire Mode	A special feature that allows the Unit to operate with ALL of the trips OFF Set "Cntrl Funct" to "D2 Fire Mode", Enabled when D2 is high Although the unit will keep running in this mode it may become damaged In some instances the damage may inhibit a subsequent starts This is only to be used in an emergency	0=Off, 1=On.	1	R		Multiplier: 1 Divisor: 1 Offset: 0 Min: 0 Max: 1 Default: 0

Modbus RTU Parameters (continued)

PNU	Name	Description	Options	Words	Type	Units	Detail
145	TempUnit	<p>Selects °C or °F for displayed temperatures</p> <p>°C: All displayed temperatures are °C</p> <p>°F: All displayed temperatures are °F</p>	0=°C, 1=°F.	1	R/W		Multiplier: 1 Divisor: 1 Offset: 0 Min: 0 Max: 1 Default: 0
146	Disp Time	<p>Time for backlight on display</p> <p>After the period set the back light on the screen will turn off</p> <p>To reactivate touch screen anywhere. To disable set to 0</p>		1	R/W	s	Multiplier: 1 Divisor: 1 Offset: 0 Min: 0 Max: 7200 Default: 60
147	CommsTime	<p>Communications trip Timeout period</p> <p>To prevent a 'Communications Trip' (If enabled) the bus must be kept active</p> <p>To keep the bus active there must be at least one Modbus read or write (any PNU) during the "Timeout ms" period</p>		1	R/W	ms	Multiplier: 1 Divisor: 1 Offset: 0 Min: 0 Max: 60000 Default: 5000
148	Address	Sets the Modbus station number		1	R/W		Multiplier: 1 Divisor: 1 Offset: 0 Min: 1 Max: 32 Default: 1

Modbus RTU Parameters (continued)

PNU	Name	Description	Options	Words	Type	Units	Detail
149	Parity	<p>Sets the serial communications parity bit</p> <p>The available parity options are None Even Odd</p> <p>Also sets the stop bits. No parity uses 2 stop bits. Odd or even parity uses 1 stop bit</p>	0=Odd, 1=Even.	1	R/W		Multiplier: 1 Divisor: 1 Offset: 0 Min: 0 Max: 1 Default: 1
150	Baud	<p>Sets the serial communications baud rate</p> <p>The available baud rates are 9600, 19200, 38400, 57600 or 115200</p>	0=9600 baud, 1=19200 baud, 2=38400 baud, 3=57600 baud, 4=115200 baud.	1	R/W		Multiplier: 1 Divisor: 1 Offset: 0 Min: 0 Max: 2 Default: 1
151	DateFormat	<p>Allows the date format to be changed</p> <p>dd/mm/yy or mm/dd/yy or yy/mm/dd</p>	0=dd/mm/yy, 1=mm/dd/yy, 2=yy/mm/dd.	1	R/W		Multiplier: 1 Divisor: 1 Offset: 0 Min: 0 Max: 2 Default: 1
153	AGY400 Ver	Displays the hardware version for the temperature sense PCB		1	R		Multiplier: 1 Divisor: 1 Offset: 0 Min: 0 Max: 65535 Default: 1

Modbus RTU Parameters (continued)

PNU	Name	Description	Options	Words	Type	Units	Detail
154	RelayFunct	Allows the n/c relay (21 -22) to be reconfigured Available options are 22 = TOR or 22 = ER	0=22 = TOR, 1=22 = ERR.	1	R/W		Multiplier: 1 Divisor: 1 Offset: 0 Min: 0 Max: 1 Default: 1
155	Reserved	No user function					
157	Window View	Used to arrange the Modbus Parameters into Group Refer to 'Special Modbus parameters' document for more details		1	R/W		Multiplier: 1 Divisor: 1 Offset: 0 Min: 0 Max: 65535 Default: 0
158	Window Code	Used to arrange the Modbus Parameters into Groups Refer to 'Special Modbus parameters' document for more details		1	R/W		Multiplier: 1 Divisor: 1 Offset: 0 Min: 0 Max: 65535 Default: 0

Modbus RTU Parameters (continued)

PNU	Name	Description	Options	Words	Type	Units	Detail
159	Reserved	No user function					
160	Patch Addr 1	Used to arrange the Modbus Parameters into Groups Refer to 'Special Modbus parameters' document for more details		1	R/W		Multiplier: 1 Divisor: 1 Offset: 0 Min: 0 Max: 65535 Default: 0
161	Patch Addr 2	Used to arrange the Modbus Parameters into Groups Refer to 'Special Modbus parameters' document for more details		1	R/W		Multiplier: 1 Divisor: 1 Offset: 0 Min: 0 Max: 65535 Default: 0
162	Patch Addr 3	Used to arrange the Modbus Parameters into Groups Refer to 'Special Modbus parameters' document for more details		1	R/W		Multiplier: 1 Divisor: 1 Offset: 0 Min: 0 Max: 65535 Default: 0

Modbus RTU Parameters (continued)

PNU	Name	Description	Options	Words	Type	Units	Detail
163	Patch Addr 4	Used to arrange the Modbus Parameters into Groups Refer to 'Special Modbus parameters' document for more details		1	R/W		Multiplier: 1 Divisor: 1 Offset: 0 Min: 0 Max: 65535 Default: 0
164	Patch Addr 5	Used to arrange the Modbus Parameters into Groups Refer to 'Special Modbus parameters' document for more details		1	R/W		Multiplier: 1 Divisor: 1 Offset: 0 Min: 0 Max: 65535 Default: 0
165	Patch Addr 6	Used to arrange the Modbus Parameters into Groups Refer to 'Special Modbus parameters' document for more details		1	R/W		Multiplier: 1 Divisor: 1 Offset: 0 Min: 0 Max: 65535 Default: 0
166	Patch Addr 7	Used to arrange the Modbus Parameters into Groups Refer to 'Special Modbus parameters' document for more details		1	R/W		Multiplier: 1 Divisor: 1 Offset: 0 Min: 0 Max: 65535 Default: 0

Modbus RTU Parameters (continued)

PNU	Name	Description	Options	Words	Type	Units	Detail
167	Patch Addr 8	Used to arrange the Modbus Parameters into Groups Refer to 'Special Modbus parameters' document for more details		1	R/W		Multiplier: 1 Divisor: 1 Offset: 0 Min: 0 Max: 65535 Default: 0
168	Patch Addr 9	Used to arrange the Modbus Parameters into Groups Refer to 'Special Modbus parameters' document for more details		1	R/W		Multiplier: 1 Divisor: 1 Offset: 0 Min: 0 Max: 65535 Default: 0
169	Patch Addr 10	Used to arrange the Modbus Parameters into Groups Refer to 'Special Modbus parameters' document for more details		1	R/W		Multiplier: 1 Divisor: 1 Offset: 0 Min: 0 Max: 65535 Default: 0
170	Patch Addr 11	Used to arrange the Modbus Parameters into Groups Refer to 'Special Modbus parameters' document for more details		1	R/W		Multiplier: 1 Divisor: 1 Offset: 0 Min: 0 Max: 65535 Default: 0

Modbus RTU Parameters (continued)

PNU	Name	Description	Options	Words	Type	Units	Detail
171	Patch Addr 12	Used to arrange the Modbus Parameters into Groups Refer to 'Special Modbus parameters' document for more details		1	R/W		Multiplier: 1 Divisor: 1 Offset: 0 Min: 0 Max: 65535 Default: 0
172	Patch Addr 13	Used to arrange the Modbus Parameters into Groups Refer to 'Special Modbus parameters' document for more details		1	R/W		Multiplier: 1 Divisor: 1 Offset: 0 Min: 0 Max: 65535 Default: 0
173	Patch Addr 14	Used to arrange the Modbus Parameters into Groups Refer to 'Special Modbus parameters' document for more details		1	R/W		Multiplier: 1 Divisor: 1 Offset: 0 Min: 0 Max: 65535 Default: 0
174	Patch Addr 15	Used to arrange the Modbus Parameters into Groups Refer to 'Special Modbus parameters' document for more details		1	R/W		Multiplier: 1 Divisor: 1 Offset: 0 Min: 0 Max: 65535 Default: 0

Modbus RTU Parameters (continued)

PNU	Name	Description	Options	Words	Type	Units	Detail
175	Patch Addr 16	Used to arrange the Modbus Parameters into Groups Refer to 'Special Modbus parameters' document for more details		1	R/W		Multiplier: 1 Divisor: 1 Offset: 0 Min: 0 Max: 65535 Default: 0
176	Window 1	Used to arrange the Modbus Parameters into Groups Refer to 'Special Modbus parameters' document for more details		1	R/W		Multiplier: 1 Divisor: 1 Offset: 0 Min: 0 Max: 65535 Default: 0
177	Window 2	Used to arrange the Modbus Parameters into Groups Refer to 'Special Modbus parameters' document for more details		1	R/W		Multiplier: 1 Divisor: 1 Offset: 0 Min: 0 Max: 65535 Default: 0
178	Window 3	Used to arrange the Modbus Parameters into Groups Refer to 'Special Modbus parameters' document for more details		1	R/W		Multiplier: 1 Divisor: 1 Offset: 0 Min: 0 Max: 65535 Default: 0

Modbus RTU Parameters (continued)

PNU	Name	Description	Options	Words	Type	Units	Detail
179	Window 4	Used to arrange the Modbus Parameters into Groups Refer to 'Special Modbus parameters' document for more details		1	R/W		Multiplier: 1 Divisor: 1 Offset: 0 Min: 0 Max: 65535 Default: 0
180	Window 5	Used to arrange the Modbus Parameters into Groups Refer to 'Special Modbus parameters' document for more details		1	R/W		Multiplier: 1 Divisor: 1 Offset: 0 Min: 0 Max: 65535 Default: 0
181	Window 6	Used to arrange the Modbus Parameters into Groups Refer to 'Special Modbus parameters' document for more details		1	R/W		Multiplier: 1 Divisor: 1 Offset: 0 Min: 0 Max: 65535 Default: 0
182	Window 7	Used to arrange the Modbus Parameters into Groups Refer to 'Special Modbus parameters' document for more details		1	R/W		Multiplier: 1 Divisor: 1 Offset: 0 Min: 0 Max: 65535 Default: 0

Modbus RTU Parameters (continued)

PNU	Name	Description	Options	Words	Type	Units	Detail
183	Window 8	Used to arrange the Modbus Parameters into Groups Refer to 'Special Modbus parameters' document for more details		1	R/W		Multiplier: 1 Divisor: 1 Offset: 0 Min: 0 Max: 65535 Default: 0
184	Window 9	Used to arrange the Modbus Parameters into Groups Refer to 'Special Modbus parameters' document for more details		1	R/W		Multiplier: 1 Divisor: 1 Offset: 0 Min: 0 Max: 65535 Default: 0
185	Window 10	Used to arrange the Modbus Parameters into Groups Refer to 'Special Modbus parameters' document for more details		1	R/W		Multiplier: 1 Divisor: 1 Offset: 0 Min: 0 Max: 65535 Default: 0
186	Window 11	Used to arrange the Modbus Parameters into Groups Refer to 'Special Modbus parameters' document for more details		1	R/W		Multiplier: 1 Divisor: 1 Offset: 0 Min: 0 Max: 65535 Default: 0

Modbus RTU Parameters (continued)

PNU	Name	Description	Options	Words	Type	Units	Detail
187	Window 12	Used to arrange the Modbus Parameters into Groups Refer to 'Special Modbus parameters' document for more details		1	R/W		Multiplier: 1 Divisor: 1 Offset: 0 Min: 0 Max: 65535 Default: 0
188	Window 13	Used to arrange the Modbus Parameters into Groups Refer to 'Special Modbus parameters' document for more details		1	R/W		Multiplier: 1 Divisor: 1 Offset: 0 Min: 0 Max: 65535 Default: 0
189	Window 14	Used to arrange the Modbus Parameters into Groups Refer to 'Special Modbus parameters' document for more details		1	R/W		Multiplier: 1 Divisor: 1 Offset: 0 Min: 0 Max: 65535 Default: 0
190	Window 15	Used to arrange the Modbus Parameters into Groups Refer to 'Special Modbus parameters' document for more details		1	R/W		Multiplier: 1 Divisor: 1 Offset: 0 Min: 0 Max: 65535 Default: 0

Modbus RTU Parameters (continued)

PNU	Name	Description	Options	Words	Type	Units	Detail
191	Window 16	Used to arrange the Modbus Parameters into Groups Refer to 'Special Modbus parameters' document for more details		1	R/W		Multiplier: 1 Divisor: 1 Offset: 0 Min: 0 Max: 65535 Default: 0
192	Window 17	Used to arrange the Modbus Parameters into Groups Refer to 'Special Modbus parameters' document for more details		1	R/W		Multiplier: 1 Divisor: 1 Offset: 0 Min: 0 Max: 65535 Default: 0
193	Window 18	Used to arrange the Modbus Parameters into Groups Refer to 'Special Modbus parameters' document for more details		1	R/W		Multiplier: 1 Divisor: 1 Offset: 0 Min: 0 Max: 65535 Default: 0
194	Window 19	Used to arrange the Modbus Parameters into Groups Refer to 'Special Modbus parameters' document for more details		1	R/W		Multiplier: 1 Divisor: 1 Offset: 0 Min: 0 Max: 65535 Default: 0

Modbus RTU Parameters (continued)

PNU	Name	Description	Options	Words	Type	Units	Detail
195	Window 20	Used to arrange the Modbus Parameters into Groups Refer to 'Special Modbus parameters' document for more details		1	R/W		Multiplier: 1 Divisor: 1 Offset: 0 Min: 0 Max: 65535 Default: 0
196	Window 21	Used to arrange the Modbus Parameters into Groups Refer to 'Special Modbus parameters' document for more details		1	R/W		Multiplier: 1 Divisor: 1 Offset: 0 Min: 0 Max: 65535 Default: 0
197	Window 22	Used to arrange the Modbus Parameters into Groups Refer to 'Special Modbus parameters' document for more details		1	R/W		Multiplier: 1 Divisor: 1 Offset: 0 Min: 0 Max: 65535 Default: 0
198	Window 23	Used to arrange the Modbus Parameters into Groups Refer to 'Special Modbus parameters' document for more details		1	R/W		Multiplier: 1 Divisor: 1 Offset: 0 Min: 0 Max: 65535 Default: 0

Modbus RTU Parameters (continued)

PNU	Name	Description	Options	Words	Type	Units	Detail
199	Window 24	Used to arrange the Modbus Parameters into Groups Refer to 'Special Modbus parameters' document for more details		1	R/W		Multiplier: 1 Divisor: 1 Offset: 0 Min: 0 Max: 65535 Default: 0
200	Total Us On	The total number of times the unit has been powered up The unit is powered up by applying a voltage to Uc Uc will be 24V or 110V/230V depending on configuration		2	R		Multiplier: 1 Divisor: 1 Offset: 0 Min: 0 Max: 65535 Default: 0
202	Total Us Off	The total number of times the unit has been powered down The unit is powered down by removing the voltage at Uc Uc will be 24V or 110V/230V depending on configuration		2	R		Multiplier: 1 Divisor: 1 Offset: 0 Min: 0 Max: 65535 Default: 0
204	Total Runs	The total number of times the unit as successfully got to the "Running" State The Running state is active when the unit is operating at full voltage When operating at full voltage the internal bypass relays are closed		2	R		Multiplier: 1 Divisor: 1 Offset: 0 Min: 0 Max: 65535 Default: 0

Modbus RTU Parameters (continued)

PNU	Name	Description	Options	Words	Type	Units	Detail
206	Total Stops	The total number of successful stops/soft stops		2	R		Multiplier: 1 Divisor: 1 Offset: 0 Min: 0 Max: 65535 Default: 0
210	Total Trips	The total number of trips		2	R		Multiplier: 1 Divisor: 1 Offset: 0 Min: 0 Max: 65535 Default: 0
211	Reserved						Multiplier: Divisor: Offset: Min: Max: Default:
212	Diagnostic 1	Used for diagnostic purposes only		1	R/W		Multiplier: 1 Divisor: 1 Offset: 0 Min: 0 Max: 65535 Default: 65535

Modbus RTU Parameters (continued)

PNU	Name	Description	Options	Words	Type	Units	Detail
213	Diagnostic 2	Used for diagnostic purposes only		1	R/W		Multiplier: 1 Divisor: 1 Offset: 0 Min: 0 Max: 65535 Default: 65535
214	Diagnostic 3	Used for diagnostic purposes only		1	R/W		Multiplier: 1 Divisor: 1 Offset: 0 Min: 0 Max: 65535 Default: 65535
215	Diagnostic 4	Used for diagnostic purposes only		1	R/W		Multiplier: 1 Divisor: 1 Offset: 0 Min: 0 Max: 65535 Default: 65535
216	Diagnostic 5	Used for diagnostic purposes only		1	R/W		Multiplier: 1 Divisor: 1 Offset: 0 Min: 0 Max: 65535 Default: 65535

Modbus RTU Parameters (continued)

PNU	Name	Description	Options	Words	Type	Units	Detail
217	Diagnostic 6	Used for diagnostic purposes only		1	R/W		Multiplier: 1 Divisor: 1 Offset: 0 Min: 0 Max: 65535 Default: 65535
218	Ovld Amps	Determines the level in Amps at which the overload will start Normally set to 115% of the set "Motor Amps" Reduce to speed up trip response		2	R/W	A	Multiplier: 1 Divisor: 1000 Offset: 0 Min: 1 x PNU18 Max: 1.25 x PNU18 Default: 1.15 x PNU18
220	Language	Selects the display language for the keypad Enter the required language from the displayed list	1=English, 2=Deutsch, 3=Francais, 4=Italiano, 5=Portugues, 6=Espanol.	1	R/W		Multiplier: 1 Divisor: 1 Offset: 0 Min: 1 Max: 10 Default: 1
221	Total Starts	The total number of successful starts		2	R		Multiplier: 1 Divisor: 1 Offset: 0 Min: 0 Max: 65535 Default: 0

Modbus RTU Parameters (continued)

PNU	Name	Description	Options	Words	Type	Units	Detail
223	L1L2L3	Determines if supply phase sequence is incorrect for motor rotation On: Trips if the phase sequence is L1-L2-L3 Off: The Unit will continue to operate normally	0=Trip Off, 1=Trip On.	1	R/W		Multiplier: 1 Divisor: 1 Offset: 0 Min: 0 Max: 1 Default: 0
224	L1L3L2	Determines if supply phase sequence is incorrect for motor rotation On: Trips if the phase sequence is L1-L3-L2 Off: The Unit will continue to operate normally	0=Trip Off, 1=Trip On.	1	R/W		Multiplier: 1 Divisor: 1 Offset: 0 Min: 0 Max: 1 Default: 0
225	RX Bytes	Diagnostic parameter for Modbus communications Indicates transmission bytes are being received		1	R		Multiplier: 1 Divisor: 1 Offset: 0 Min: 0 Max: 65535 Default: 0
226	RX Frames	Diagnostic parameter for Modbus communications Indicates transmission frames are being received		1	R		Multiplier: 1 Divisor: 1 Offset: 0 Min: 0 Max: 65535 Default: 0

Modbus RTU Parameters (continued)

PNU	Name	Description	Options	Words	Type	Units	Detail
227	RX Errors	Diagnostic parameter for Modbus communications Indicates whether the data has errors		1	R		Multiplier: 1 Divisor: 1 Offset: 0 Min: 0 Max: 65535 Default: 0
228	RX TMO Er	Diagnostic parameter for Modbus communications Indicates a timing error		1	R		Multiplier: 1 Divisor: 1 Offset: 0 Min: 0 Max: 65535 Default: 0
229	TX Bytes	Diagnostic parameter for Modbus communications Indicates transmission bytes are being sent		1	R		Multiplier: 1 Divisor: 1 Offset: 0 Min: 0 Max: 65535 Default: 0
230	TX Frames	Diagnostic parameter for Modbus communications Indicates transmission frames are being sent		1	R		Multiplier: 1 Divisor: 1 Offset: 0 Min: 0 Max: 65535 Default: 0

Modbus RTU Parameters (continued)

PNU	Name	Description	Options	Words	Type	Units	Detail
231	TX Errors	Diagnostic parameter for Modbus communications Indicates whether the data has errors		1	R		Multiplier: 1 Divisor: 1 Offset: 0 Min: 0 Max: 65535 Default: 0
232	StopCode File	Diagnostic parameter For Motortronics UK use only		1	R		Multiplier: 1 Divisor: 1 Offset: 0 Min: 0 Max: 65535 Default: 65535
233	StopCode File_1	Diagnostic parameter For Motortronics UK use only		1	R		Multiplier: 1 Divisor: 1 Offset: 0 Min: 0 Max: 65535 Default: 65535
234	StopCode Pos	Diagnostic parameter For Motortronics UK use only		1	R		Multiplier: 1 Divisor: 1 Offset: 0 Min: 0 Max: 65535 Default: 65535

Modbus RTU Parameters (continued)

PNU	Name	Description	Options	Words	Type	Units	Detail
235	StopCode Pos_1	Diagnostic parameter For Motortronics UK use only		1	R		Multiplier: 1 Divisor: 1 Offset: 0 Min: 0 Max: 65535 Default: 65535
236	Limit Amps	The current in Amps at which the soft stop ramp is not allowed to go above Normally set to 350% motor FLC. Increase if motor decelerates too rapidly The current limit level will affect actual time to stop the motor		2	R/W	A	Multiplier: 1 Divisor: 1000 Offset: 0 Min: 0.5 x PNU18 Max: 5 x PNU20 Default: 5 x PNU20
238	Limit Time	The maximum time allowed for the current limit If the current limit is still active at the end of this period the Unit will either trip or continue		1	R/W	s	Multiplier: 1 Divisor: 1 Offset: 0 Min: 1 Max: 60 Default: 2
239	I Low Amps	The current in Amps that will cause a trip A trip will occur if the motor current is less than the "I Low Amps" level for the "I Low Time"		2	R/W	A	Multiplier: 1 Divisor: 1000 Offset: 0 Min: 0.25 x PNU18 Max: 1 x PNU18 Default: 0.25 x PNU18

Modbus RTU Parameters (continued)

PNU	Name	Description	Options	Words	Type	Units	Detail
241	I Low Time	The trip time for the Low current trip A trip will occur if the motor current is less than the "I Low Amps" level for the "I Low Time"		1	R/W	s	Multiplier: 1 Divisor: 1 Offset: 0 Min: 1 Max: 60 Default: 30
242	I Limit Stop	Selects trip or continue if the current limit has been active for too long Trip On: The Unit will trip Trip Off: The stop will continue regardless of the motor current level	0=Trip Off, 1=Trip On.	1	R/W		Multiplier: 1 Divisor: 1 Offset: 0 Min: 0 Max: 1 Default: 0
243	Keypad Pwr	Connects the 24V dc supply a pin on the RJ45 connector Must be turned "On" if the remote keypad is connected	0=Off, 1=On.	1	R/W		Multiplier: 1 Divisor: 1 Offset: 0 Min: 0 Max: 1 Default: 0
244	Service No.	Diagnostic parameter For Motortronics UK use only		1	R/W		Multiplier: 1 Divisor: 1 Offset: 0 Min: 0 Max: 65535 Default: 0

Modbus RTU Parameters (continued)

PNU	Name	Description	Options	Words	Type	Units	Detail
245	Scroll	Used to allow the text to scroll on the keypad On: If the text is too long for the display it will scroll Off: If the text is too long for the display the message will be truncated	0=Off, 1=On.	1	R/W		Multiplier: 1 Divisor: 1 Offset: 0 Min: 0 Max: 1 Default: 1
246	Reset Ovld	Factory parameter Motortronics UK use only	0=Off, 1=On.	1	R/W		Multiplier: 1 Divisor: 1 Offset: 0 Min: 0 Max: 1 Default: 0
247	StartsHr	When the fan is connected the number of fully rated starts can be increased Without the fan connected the number of fully rated starts is 5 With the fan connected the number of fully rated starts is 40		1	R		Multiplier: 1 Divisor: 1 Offset: 0 Min: 0 Max: 65535 Default: 0
248	Initial Deg C	Displays the temperature of the heatsink at the beginning of the start		1	R	C	Multiplier: 1 Divisor: 1 Offset: 0 Min: 0 Max: 65535 Default: 0

Modbus RTU Parameters (continued)

PNU	Name	Description	Options	Words	Type	Units	Detail
258	Auto Reset	<p>Enables the Auto Reset Feature</p> <p>Refer to Auto Reset section for more details</p> <p>On: The Auto Reset feature is enabled</p> <p>Off: The Auto Reset feature is disabled and all counters will be re-initialised</p>	0=Off, 1=On	1	R/W		Multiplier: 1 Divisor: 1 Offset: 0 Min: 0 Max: 1 Default: 0
259	Reset Delay	<p>The delay between the trip event and the automatic reset, the unit will re-start following the reset if the start signal is active</p> <p>If this is set to zero at any point the Auto Reset feature will terminate and the counters will be re-initialised</p> <p>When the delay is active the Restart Pending parameter is set and the time remaining can be viewed in the monitor menu</p>		1	R/W	s	Multiplier: 1 Divisor: 1 Offset: 0 Min: 0 Max: 7200 Default: 0
260	Reset Attempts	<p>The number of restart attempts allowed before the Auto Reset terminates. If the Auto Reset has been successful, the counter is reset back to its maximum value when the unit has been running fault free for the Trip Free Time</p> <p>If the Auto Restart has been unsuccessful the counters are re-initialised by applying a reset signal or removing the start signal. If this PNU is set to zero at any point the Auto Reset feature will terminate and the counters will be re-initialise</p> <p>The number of attempts remaining can be viewed in the Monitor menu</p>		1	R/W		Multiplier: 1 Divisor: 1 Offset: 0 Min: 0 Max: 10 Default: 0

Modbus RTU Parameters (continued)

PNU	Name	Description	Options	Words	Type	Units	Detail
261	Trip Free Time	<p>The time the unit must be run trip free before the counters are re-initialised back to zero</p> <p>If this PNU is set to zero at any point the Auto Reset feature will terminate and the counters will be re-initialised</p> <p>The Trip Free Time can be viewed in the Monitor menu</p>		1	R/W	s	Multiplier: 1 Divisor: 1 Offset: 0 Min: 0 Max: 7200 Default: 600
262	Phase Loss	<p>Allows the user to select whether the unit will auto reset if a Phase Loss Trip occurs</p> <p>On: The trip will auto reset when the Reset Delay reaches zero</p> <p>Off: The trip will not auto reset</p>	0=Off, 1=On	1	R/W		Multiplier: 1 Divisor: 1 Offset: 0 Min: 0 Max: 1 Default: 1
263	Thermal	<p>Allows the user to select whether the unit will auto reset if a Thermal Trip occurs</p> <p>On: The trip will auto reset when the Reset Delay reaches zero</p> <p>Off: The trip will not auto reset</p>	0=Off, 1=On	1	R/W		Multiplier: 1 Divisor: 1 Offset: 0 Min: 0 Max: 1 Default: 1
264	ScrFire	<p>Allows the user to select whether the unit will auto reset if a ScrFire Trip occurs</p> <p>On: The trip will auto reset when the Reset Delay reaches zero</p> <p>Off: The trip will not auto reset</p>	0=Off, 1=On	1	R/W		Multiplier: 1 Divisor: 1 Offset: 0 Min: 0 Max: 1 Default: 1
265	Ph / SCR	<p>Allows the user to select whether the unit will auto reset if a Ph/SCR Trip occurs</p> <p>On: The trip will auto reset when the Reset Delay reaches zero</p> <p>Off: The trip will not auto reset</p>	0=Off, 1=On	1	R/W		Multiplier: 1 Divisor: 1 Offset: 0 Min: 0 Max: 1 Default: 1

Modbus RTU Parameters (continued)

PNU	Name	Description	Options	Words	Type	Units	Detail
266	HzHighLow	Allows the user to select whether the unit will auto reset if a HzHighLow Trip occurs On: The trip will auto reset when the Reset Delay reaches zero Off: The trip will not auto reset	0=Off, 1=On	1	R/W		Multiplier: 1 Divisor: 1 Offset: 0 Min: 0 Max: 1 Default: 1
267	UcLow	Allows the user to select whether the unit will auto reset if a UcLow Trip occur On: The trip will auto reset when the Reset Delay reaches zero Off: The trip will not auto reset	0=Off, 1=On	1	R/W		Multiplier: 1 Divisor: 1 Offset: 0 Min: 0 Max: 1 Default: 1
268	SCRSen	Allows the user to select whether the unit will auto reset if a SCRSen Trip occurs On: The trip will auto reset when the Reset Delay reaches zero Off: The trip will not auto reset	0=Off, 1=On	1	R/W		Multiplier: 1 Divisor: 1 Offset: 0 Min: 0 Max: 1 Default: 1
269	Fan	Allows the user to select whether the unit will auto reset if a Fan Trip occurs On: The trip will auto reset when the Reset Delay reaches zero Off: The trip will not auto reset	0=Off, 1=On	1	R/W		Multiplier: 1 Divisor: 1 Offset: 0 Min: 0 Max: 1 Default: 1
270	Spare900	Allows the user to select whether the unit will auto reset if a Spare900 Trip occurs On: The trip will auto reset when the Reset Delay reaches zero Off: The trip will not auto reset	0=Off, 1=On	1	R/W		Multiplier: 1 Divisor: 1 Offset: 0 Min: 0 Max: 1 Default: 1

Modbus RTU Parameters (continued)

PNU	Name	Description	Options	Words	Type	Units	Detail
271	Spare1000	Allows the user to select whether the unit will auto reset if a Spare1000 Trip occurs On: The trip will auto reset when the Reset Delay reaches zero Off: The trip will not auto reset	0=Off, 1=On	1	R/W		Multiplier: 1 Divisor: 1 Offset: 0 Min: 0 Max: 1 Default: 1
272	I Low	Allows the user to select whether the unit will auto reset if a I LOW Trip occurs On: The trip will auto reset when the Reset Delay reaches zero Off: The trip will not auto reset	0=Off, 1=On	1	R/W		Multiplier: 1 Divisor: 1 Offset: 0 Min: 0 Max: 1 Default: 1
273	I Limit	Allows the user to select whether the unit will auto reset if a I Limit Trip occurs On: The trip will auto reset when the Reset Delay reaches zero Off: The trip will not auto reset	0=Off, 1=On	1	R/W		Multiplier: 1 Divisor: 1 Offset: 0 Min: 0 Max: 1 Default: 1
274	Overload	Allows the user to select whether the unit will auto reset if a Overload Trip occurs On: The trip will auto reset when the Reset Delay reaches zero Off: The trip will not auto reset	0=Off, 1=On	1	R/W		Multiplier: 1 Divisor: 1 Offset: 0 Min: 0 Max: 1 Default: 1
275	Shearpin	Allows the user to select whether the unit will auto reset if a Shearpin Trip occurs On: The trip will auto reset when the Reset Delay reaches zero Off: The trip will not auto reset	0=Off, 1=On	1	R/W		Multiplier: 1 Divisor: 1 Offset: 0 Min: 0 Max: 1 Default: 1

Modbus RTU Parameters (continued)

PNU	Name	Description	Options	Words	Type	Units	Detail
276	Spare1500	Allows the user to select whether the unit will auto reset if a Spare1500 Trip occurs On: The trip will auto reset when the Reset Delay reaches zero Off: The trip will not auto reset	0=Off, 1=On	1	R/W		Multiplier: 1 Divisor: 1 Offset: 0 Min: 0 Max: 1 Default: 1
277	External	Allows the user to select whether the unit will auto reset if a External Trip occurs On: The trip will auto reset when the Reset Delay reaches zero Off: The trip will not auto reset	0=Off, 1=On	1	R/W		Multiplier: 1 Divisor: 1 Offset: 0 Min: 0 Max: 1 Default: 0
278	Comms	Allows the user to select whether the unit will auto reset if a Comms Trip occurs On: The trip will auto reset when the Reset Delay reaches zero Off: The trip will not auto reset	0=Off, 1=On	1	R/W		Multiplier: 1 Divisor: 1 Offset: 0 Min: 0 Max: 1 Default: 1
279	Bypass	Allows the user to select whether the unit will auto reset if a Bypass Trip occurs On: The trip will auto reset when the Reset Delay reaches zero Off: The trip will not auto reset	0=Off, 1=On	1	R/W		Multiplier: 1 Divisor: 1 Offset: 0 Min: 0 Max: 1 Default: 1
280	Control	Allows the user to select whether the unit will auto reset if a Control Trip occurs On: The trip will auto reset when the Reset Delay reaches zero Off: The trip will not auto reset	0=Off, 1=On	1	R/W		Multiplier: 1 Divisor: 1 Offset: 0 Min: 0 Max: 1 Default: 1

Modbus RTU Parameters (continued)

PNU	Name	Description	Options	Words	Type	Units	Detail
281	Remote	Allows the user to select whether the unit will auto reset if a Remote Trip occurs On: The trip will auto reset when the Reset Delay reaches zero Off: The trip will not auto reset	0=Off, 1=On	1	R/W		Multiplier: 1 Divisor: 1 Offset: 0 Min: 0 Max: 1 Default: 1
282	Rotation	Allows the user to select whether the unit will auto reset if a Rotation Trip occurs On: The trip will auto reset when the Reset Delay reaches zero Off: The trip will not auto reset	0=Off, 1=On	1	R/W		Multiplier: 1 Divisor: 1 Offset: 0 Min: 0 Max: 1 Default: 1
283	Operation 1	Allows the user to select whether the unit will auto reset if a Operation1 Trip occurs On: The trip will auto reset when the Reset Delay reaches zero Off: The trip will not auto reset	0=Off, 1=On	1	R/W		Multiplier: 1 Divisor: 1 Offset: 0 Min: 0 Max: 1 Default: 1
284	CT Fault	Allows the user to select whether the unit will auto reset if a CT Fault Trip occurs On: The trip will auto reset when the Reset Delay reaches zero Off: The trip will not auto reset	0=Off, 1=On	1	R/W		Multiplier: 1 Divisor: 1 Offset: 0 Min: 0 Max: 1 Default: 1
285	Operation 2	Allows the user to select whether the unit will auto reset if a Operation2 Trip occurs On: The trip will auto reset when the Reset Delay reaches zero Off: The trip will not auto reset	0=Off, 1=On	1	R/W		Multiplier: 1 Divisor: 1 Offset: 0 Min: 0 Max: 1 Default: 1

Modbus RTU Parameters (continued)

PNU	Name	Description	Options	Words	Type	Units	Detail
286	Operation 3	Allows the user to select whether the unit will auto reset if a Operation3 Trip occurs On: The trip will auto reset when the Reset Delay reaches zero Off: The trip will not auto reset	0=Off, 1=On	1	R/W		Multiplier: 1 Divisor: 1 Offset: 0 Min: 0 Max: 1 Default: 1
287	Operation 4	Allows the user to select whether the unit will auto reset if a Operation4 Trip occurs On: The trip will auto reset when the Reset Delay reaches zero Off: The trip will not auto reset	0=Off, 1=On	1	R/W		Multiplier: 1 Divisor: 1 Offset: 0 Min: 0 Max: 1 Default: 1
288	Operation 5	Allows the user to select whether the unit will auto reset if a Operation5 Trip occurs On: The trip will auto reset when the Reset Delay reaches zero Off: The trip will not auto reset	0=Off, 1=On	1	R/W		Multiplier: 1 Divisor: 1 Offset: 0 Min: 0 Max: 1 Default: 1
289	Operation 6	Allows the user to select whether the unit will auto reset if a Operation6 Trip occurs On: The trip will auto reset when the Reset Delay reaches zero Off: The trip will not auto reset	0=Off, 1=On	1	R/W		Multiplier: 1 Divisor: 1 Offset: 0 Min: 0 Max: 1 Default: 1
290	Operation 7	Allows the user to select whether the unit will auto reset if a Operation7 Trip occurs On: The trip will auto reset when the Reset Delay reaches zero Off: The trip will not auto reset	0=Off, 1=On	1	R/W		Multiplier: 1 Divisor: 1 Offset: 0 Min: 0 Max: 1 Default: 1

Modbus RTU Parameters (continued)

PNU	Name	Description	Options	Words	Type	Units	Detail
291	Operation 8	Allows the user to select whether the unit will auto reset if a Operation8 Trip occurs On: The trip will auto reset when the Reset Delay reaches zero Off: The trip will not auto reset	0=Off, 1=On	1	R/W		Multiplier: 1 Divisor: 1 Offset: 0 Min: 0 Max: 1 Default: 1
292	Operation 9	Allows the user to select whether the unit will auto reset if a Operation9 Trip occurs On: The trip will auto reset when the Reset Delay reaches zero Off: The trip will not auto reset	0=Off, 1=On	1	R/W		Multiplier: 1 Divisor: 1 Offset: 0 Min: 0 Max: 1 Default: 1
293	Operation 10	Allows the user to select whether the unit will auto reset if a Operation10 Trip occurs On: The trip will auto reset when the Reset Delay reaches zero Off: The trip will not auto reset	0=Off, 1=On	1	R/W		Multiplier: 1 Divisor: 1 Offset: 0 Min: 0 Max: 1 Default: 1
294	AR Pending	Indicates that the Reset Delay counter is counting down Yes: The Auto Reset Delay is counting down No: The Auto Reset Delay is not counting down To map to digital output refer to PNU154/PNU300		1	R		Multiplier: 1 Divisor: 1 Offset: 0 Min: 0 Max: 65535 Default: 0
295	AR Exceeded	Indicates that the maximum number of reset attempts has been reached Yes: The number of reset attempts has exceeded the value set No: The number of reset attempts has not exceeded the value set To map to digital output refer to PNU154/PNU300		1	R		Multiplier: 1 Divisor: 1 Offset: 0 Min: 0 Max: 65535 Default: 0

Modbus RTU Parameters (continued)

PNU	Name	Description	Options	Words	Type	Units	Detail
296	AR Delay	The amount of time remaining in the Reset Delay counter		1	R	s	Multiplier: 1 Divisor: 1 Offset: 0 Min: 0 Max: 65535 Default: 0
297	AR Attempts	The number of Reset Attempts remaining		1	R		Multiplier: 1 Divisor: 1 Offset: 0 Min: 0 Max: 65535 Default: 0
298	AR Trip Free	The amount of time remaining in the Trip Free Time counter		1	R	s	Multiplier: 1 Divisor: 1 Offset: 0 Min: 0 Max: 65535 Default: 0
299	AR Trip Event	The trip that occurred just prior to the auto reset		1	R		Multiplier: 1 Divisor: 1 Offset: 0 Min: 0 Max: 65535 Default: 0
300	Relay 13 14	Allows the n/c relay (13 -14) to be reconfigured Available options are End Of Start or Fault or Run or Pending or Exceeded	0=End of start 1=Fault 2=Run 3=Pending 4=Exceeded	1	R/W		Multiplier: 1 Divisor: 1 Offset: 0 Min: 0 Max: 4 Default: 2

Modbus RTU Parameters (continued)

Table 1	
<i>PNU 16 Value</i>	<i>Auto Application</i>
0	Default
1	Heavy
2	Agitator
3	Compressor 1
4	Compressor 2
5	Conveyor Loaded
6	Conveyor Unloaded
7	Crusher
8	Fan High Inertia
9	Fan Low Inertia
10	Grinder
11	Mill
12	Mixer
13	Moulding M/C
14	Press Flywheel
15	Pump 1
16	Pump 2
17	PumpJack
18	Saw-Band
19	Saw-Circular
20	Screen Vibrating
21	Shredder
22	Woodchipper

Table 2	
<i>PNU 24 Value</i>	<i>Status</i>
20	Starting
22	Fire Mode
25	Limit Start
35	Limit Stop
40	Stopping
60	Running
128	Ready
140	Tripped
200	Disabled
250	Initialisation

Modbus RTU Parameters (continued)

Table 3	
PNU 78 thru 85	Trip Status
100	Ph Loss
200	Thermal
300	Ph/SCR
400	Mot Side
500	Freq
600	Uc Low
700	SCR Sen
800	Fan
1000	SCR S/C
1100	Low Amp
1200	Limit
1300	Overload
1400	Shear
1500	PTC
1600	External
1700	Comms
1800	Bypass
1900	FireMode
2000	Remote
2100	Rotation
2200	Op1
2300	CT Fault
1100	Op2 Pnu
1200	Op2 Mod
13000	Op2 Mon
14000	Op2 Men
15000	Op2 Keys
16000	Op2 Motr
17000	Op2 Log
18000	Op2 Disk

Modbus RTU Parameters (continued)

Special Modbus Registers

List of **special** Modbus registers, descriptions, and usage.

Window registers section

There is a section of Modbus registers that can be used for special (user programmable) purposes.

Register Name	Reg ID	Description
Window View	157	Selects what is viewed through the window 0 – Patched Registers 1 – Log Records
Window Code	158	Log Record function 0 – None 1 – Report 2 – Rewind 3 – Unwind 4 – Seek Absolute 5 – Seek Relative 6 – Next Record 16 – Auto Increment
Reserved	159	For future functionality
Patch Address 1 to 16	160 to 175	16 place holders for the registers that need to be patched
Window 1 to 24	176 to 199	Either: If Window View set to 0 16 data holders related to the selected addresses in the Patch Address section (in Window 1 to 16 only) Or For Window View set to 1 All 24 words to hold the currently select log record

Currently there are two uses for this group of Modbus registers. (1) Register patching and (2) Log record access.

1) Register patching.

Register patching is enabled when the Window View register (address 157) is set a to Patched Registers (value 0).

It allows the user to patch (re-map) a selection of disparate registers into a contiguous register section or window, so that retrieval of the most requested data can be handled in more efficient single block reads by a host controller (PLC). When the address of a register is placed in the Patch section (addresses 160 to 175) then the corresponding 16 bit WORD(s) in the Window section (addresses 176 to 192) will mirror the data and function of those registers.

Modbus RTU Parameters (continued)

For example, if address 24 (Motor State) is set into register 160 (first Patch Address) then the value report at 176 (first Window address) will be the Motor State from then on.

Register Name	Register Number	Register Value	⇒	Patch Register	Patch Value	Window Register	Window Value
Motor State	24	128		160	24	176	128

Consideration needs to be given to registers that produce multiple WORD data. For example, address 22 (Unit Amps) produces a 32 bit or 2 WORD datum. To mirror both of those WORDs into the Window both registers 22 and 23 will need to be assigned (side by side) in to the corresponding Patch Address section.

Register Name	Register Number	Register Value	⇒	Patch Register	Patch Value	Window Register	Window Value
Unit Amps	22	0		160	22	176	0
		5500		161	23 Or 0	177	5500

It follows that the entire 16 Aliases can be populated with a mixture of the required data, that can then be queried from (or set to, with writable registers) with a 16 word Modbus transaction frame.

Register Name	Register Number	Register Value	⇒	Patch Register	Patch Value	Window Register	Window Value
Serial Number	7	0x0041		160	7	176	0x0041
		0x3132		161	8 or 0	177	0x3132
		0x3334		162	9 or 0	178	0x3334
		0x3536		163	10 or 0	179	0x3536
Motor State	24	128	⇒	164	24	180	128
Unit Amps	22	0	⇒	165	22	181	0
		5500		167	23 Or 0	182	5500

Modbus RTU Parameters (continued)

2) Log record access.

Log record access is enabled when the Window View register (register 157) is set a to Log Records (value 1).

When Log record access is selected these can be accessed by assigning Register address 158 (Window Code) with a one of the function code values described here.

a) Report (address 158 set to value 1)

If Window Code is set to When 1 the Window registers are filled with information about the first and last record in the event log, in the following arrangement.

Window Register numbers	Description of data copied
176,177	Index number of first record
178,179,180	Date and Time when the event was recorded of first record. See date Time format in Appendix
181,182	Index number of last record
183,184,185	Date and Time when the last event was recorded. See date Time format. TBD

b) Rewind (2)

Setting Window Code to 2 will rewind the log record pointer to the first record. Subsequently when the Next Record is requested the data from the first record will be placed into the Window registers.

c) Unwind (3)

Setting Window Code to 3 will set the log record pointer to the last created record. Subsequently when the Next Record is requested the data from the last record will be placed into the Window registers.

d) Seek Absolute (4)

Setting Window Code to 4 along with setting Window 1 and 2 to the required record pointer will prepare the Next Record request to return the record with that record number.

e) Seek Relative (5)

When setting Window Code to 5, the **signed** number set into Window 1 and 2 will added to the current pointer so the Next Record request will return the record whose position is offset by that number.

f) Next Record (6)

Setting Window Code to 6 will cause the log record with the position of the current record pointer to be copied into the Window registers (addresses 176 to 199). These will then contain the following information.

Modbus RTU Parameters (continued)

Generic Word PNU Register number	Data Description
176,177	Record Index number
178,179,180	Date and Time when the event was recorded. See date Time format. See appendix
181	Event type. See event type codes. See appendix
181 to 199	Event data. See event data. See appendix

g) Auto Increment (16)

If this value can be added (OR'ed) in with Next record ($6 + 16 = 22$) then each Modbus read of the Window 1 register, with or without a block read of the following 23 registers, will automatically increment the record pointer so that the next read will return information from the next record. This avoids the need to do a Next Record request before each record read. Note that if register Window 1 is read on its own, as one Modbus transaction, the subsequent reads the other higher Window registers will be from the next record. Block reads of all 24 registers is required for this function to successfully.

When an event row is request, after a Next Record function or an Auto Increment, the values recorded for that record are placed in the Window addresses 176 to 199. Specified in the table below.

Generic Word PNU Register number	Data Description
176,177	Record Index number
178,179,180	Date and Time when the event was recorded. See date Time format
181	Event type. See event type codes
182 to 199	Event data. See event data

The Date and Time is recorded in three consecutive registers. This is true for Modbus registers Date, Time, Saved Date, Saved Time and the Time stamps shown in the table below:

Register Ordinal	Description	Detail Bit Layout of each 16 bit words	
1	Date	Bits 0 - 4	Day (1 – 31)
		Bits 5 - 8	Month (1 – 12)
		Bits 9 - 15	Year (00 – 127) -> (2000 - 2127)
2	Time 1 (Hours, Minutes)	Bits 0 - 5	Minute (0 – 59)
		Bits 6 - 10	Hour (0 – 23)
		Bits 11 - 15	Unused
3	Time 2 (Milliseconds)	Bits 0 - 9	Milliseconds (0 – 999)
		Bits 10 - 15	Seconds (0 – 59)

Modbus RTU Parameters (continued)

Event Type Codes represent what kind of event the proceeding data represents.

Code	Meaning
1	Initialise (boot up)
10	Power Off
50	Start Signal
100	Motor Run
300	Motor Dwell
600	Motor Stop
900	Motor Tripped

Depending on the event type code the register addresses 182 to 197 will contain data that is described in the following table.

Addr	Event Type						
	<i>Initialise</i>	<i>Power Off</i>	<i>Start Signal</i>	<i>Motor Run</i>	<i>Motor Dwell</i>	<i>Motor Stop</i>	<i>Motor Tripped</i>
182	Version	Version	Version	Start Delay	I rms	I rms	I rms
183	Model No	AGY100 Ver	Model Number	Frequency	I1 rms	I1 rms	StopCodeFile
184	Unit Amps	AGY200 Ver	Unit Amps	Rot Degrees	I2 rms	I2 rms	StopCodeFile_1
185	Rated Amps	AGY300 Ver	Rated Amps	Rotation	I3 rms	I3 rms	StopCodeFile
186	Motor Amps	AGY400 Ver	Motor Amps	Trip Class	Stop Time	I Stop	StopCodeFile_1
187	MenuBuild	ODB Type	MenuBuild	Initial Volts	I Limit Stop	T Stop	StopCodePos
188	Motor State Save	OverloadSave	Op Mode	Start Time	Limit Amps	Diagnostic 1	StopCodePos_1
189	OverloadSave	Diagnostic 2	Fire Mode	StartsHr	Limit Time	Diagnostic 2	I Start
190	Keypad Pwr	Diagnostic 3	Trip Class	Limit Amps	I Start	Diagnostic 3	T Start
191	Trip Class	Diagnostic 4	Application	Limit Time	T Start	Diagnostic 4	I Stop
192	Application	Diagnostic 5	Cntrl Mode	Shear Amps	Initial Temp	Diagnostic 5	T Stop
193	Language	Diagnostic 6	Cntrl Funct	Shear Tlme	I Low Amps	Diagnostic 6	CommsTime
194	I Low	Phase Loss	Relay 21 22	Ovld Amps	I Low Time	Delay Angle	Delay Angle
195	Shearpin	Sensor Loss	Reset Attempts	HS Temp	HS Temp	HS Temp	HS Temp
196	Hz HighLow	Ph/SCR	AR Attempts	Trip Sens	Overload	Overload	Overload
197	Overload	CT Fault	Kick Start	Overload	Last Warn	Last Warn	Last Trip

Modbus RTU Parameters (continued)

Memory Probes

Each register WORD is used as two BYTES. Each byte showing the current amount of available memory for each designation. These are used within the firmware to record and respond to low memory situations in the device operating system. Note that these have a maximum value of 0xff or 255. 0xff could mean a value greater than 0xff, so it works as a soft limit. In normal and stressed operation, it is desirable that these values never reach zero.

Register Name	Reg ID	Size	Description Free Memory
Main Memory Free	212	2 x BYTE	MSByte – Main Stack LSByte – Main Heap
Task 1&2 Free Stack	213	2 x BYTE	MSByte – Task 1 Stack (Monitor) LSByte – Task 2 Stack (IDLE)
Task 3&4 Free Stack	214	2 x BYTE	MSByte – Task 3 Stack (Keys) LSByte – Task 4 Stack (Menu)
Task 5&6 Free Stack	215	2 x BYTE	MSByte – Task 5 Stack (PNU) LSByte – Task 6 Stack (Modbus)
Task 7&8 Free Stack	216	2 x BYTE	MSByte – Task 7 Stack (Disk) LSByte – Task 8 Stack (Log)
Task 9&10 Free Stack	217	2 x BYTE	MSByte – Task 9 Stack (Reserved) LSByte – Task 10 Stack (Motor)

Modbus RTU Parameters (continued)

Modbus PNU Alphabetical Cross Reference

(AR = Auto Reset)

PNU	Name	PNU	Name	PNU	Name	PNU	Name
148	Address	216	Diagnostic 5	250	Irms	291	Operation8
48	AGY100 Ver	217	Diagnostic 6	243	Keypad Pwr	292	Operation9
103	AGY200 Ver	146	Disp Time	87	Kick Level	27	Overload
104	AGY300 Ver	277	External	89	Kick Start	60	Overload
153	AGY400 Ver	31	Factory Rst	88	Kick Time	274	Overload
16	Application	269	Fan	223	L1L2L3	218	Ovld Amps
297	AR Attempts	143	Fire Mode	224	L1L3L2	149	Parity
296	AR Delay	30	Frequency	220	Language	160	Patch Addr 1
295	AR Exceeded	91	From USB	69	Limit Amps	169	Patch Addr 10
294	AR Pending	39	HS Temp	236	Limit Amps	170	Patch Addr 11
299	AR Trip Event	40	HS Temp	71	Limit Time	171	Patch Addr 12
298	AR Trip Free	53	Hz HighLow	238	Limit Time	172	Patch Addr 13
258	Auto Reset	266	HzHighLow	86	MenuBuild	173	Patch Addr 14
150	Baud	273	I Limit	119	Modbus Enable	174	Patch Addr 15
72	Boot Ver	59	I Limit Start	121	Modbus Reset	175	Patch Addr 16
279	Bypass	242	I Limit Stop	120	Modbus Start	161	Patch Addr 2
74	Cntrl Funct	272	I Low	11	Model No	162	Patch Addr 3
1	Cntrl Mode	58	I Low	18	Motor Amps	163	Patch Addr 4
278	Comms	239	I Low Amps	24	Motor State	164	Patch Addr 5
64	Comms	241	I Low Time	159	ODB Type	165	Patch Addr 6
147	CommsTime	25	I rms	75	Op Mode	166	Patch Addr 7
280	Control	94	I Start	68	Operation 1	167	Patch Addr 8
67	CT Fault	96	I Stop	283	Operation 1	168	Patch Addr 9
284	CT Fault	41	I1 rms	109	Operation 2	51	Ph/SCR
34	Date	251	I1 rms	293	Operation10	265	Ph/SCR
151	DateFormat	43	I2 rms	285	Operation2	49	Phase Loss
47	Delay Angle	252	I2 rms	286	Operation3	262	Phase Loss
212	Diagnostic 1	45	I3 rms	287	Operation4	20	Rated Amps
213	Diagnostic 2	253	I3 rms	288	Operation5	300	Relay 13 14
214	Diagnostic 3	248	Initial Temp	289	Operation6	154	Relay 21 22
215	Diagnostic 4	2	Initial Volts	290	Operation7	281	Remote (AR)

Continued overleaf

Modbus RTU Parameters (continued)

Modbus PNU Alphabetical Cross Reference (continued)

66	Remote	97	T Stop	176	Window 1
110	Rerate Key	145	TempUnit	185	Window 10
155	Rerate USB	263	Thermal	186	Window 11
260	Reset Attempts	35	Time	187	Window 12
259	Reset Delay	90	To USB	188	Window 13
37	Rotation	98	Total Events	189	Window 14
282	Rotation	204	Total Runs	190	Window 15
225	RX Bytes	221	Total Starts	191	Window 16
227	RX Errors	206	Total Stops	192	Window 17
226	RX Frames	210	Total Trips	193	Window 18
228	RX TMO Er	106	Total Uc On	194	Window 19
33	Save Log	202	Total Us Off	177	Window 2
264	ScrFire	200	Total Us On	195	Window 20
245	Scroll	77	Trip 0	196	Window 21
268	SCRSen	78	Trip 1	197	Window 22
50	Sensor Loss	79	Trip 2	198	Window 23
7	Serial No	80	Trip 3	199	Window 24
244	Service No	81	Trip 4	178	Window 3
114	Shear Amps	82	Trip 5	179	Window 4
116	Shear Tlme	83	Trip 6	180	Window 5
61	Shearpin	84	Trip 7	181	Window 6
275	Shearpin	85	Trip 8	182	Window 7
6	Start Delay	17	Trip Class	183	Window 8
4	Start Time	261	Trip Free Time	184	Window 9
247	StartsHr	152	Trip Sens	158	Window Code
5	Stop Time	229	TX Bytes	157	Window View
232	StopCodeFile	231	TX Errors		
233	StopCodeFile_1	230	TX Frames		
234	StopCodePos	267	UcLow		
235	StopCodePos_1	22	Unit Amps		
95	T Start	14	Version		

Updating Firmware

Update Procedure

In the event that the VMX-agility™ unit requires a firmware update, this can be achieved on an installed unit without the need for any additional equipment other than a USB memory stick.

Instruction for Updating



- Obtain a USB flash drive, and ensure that it has been formatted to FAT32.
Part number USB-KEY is a USB flash drive that has been verified to work with VMX-agility™. Other flash drives may not physically fit, or may not perform correctly. Available to purchase from Motortronics UK Ltd.
- Download a new firmware zip file from: <https://www.motortronics-uk.co.uk/agility/downloads/>
- Copy the zip file into a suitable location on your PC that you can extract all of the firmware files

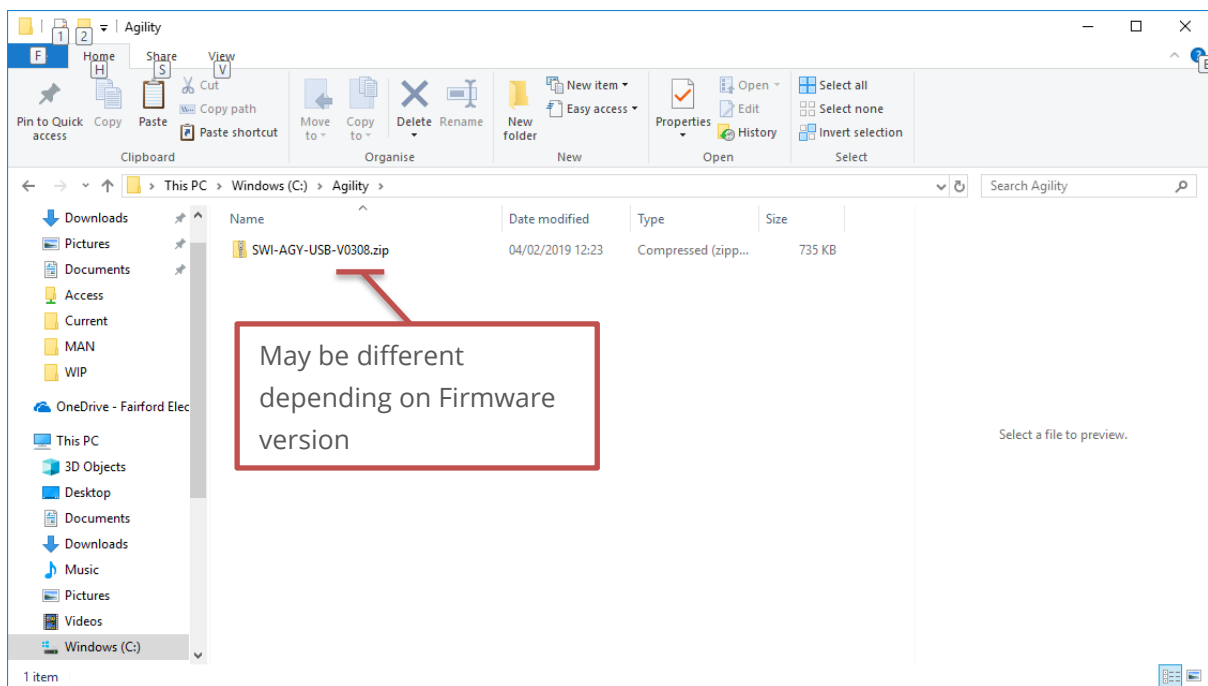

- Right click on the zip file and select extract all. This will create an unzipped directory in the same location with the same name.

Continued over

Updating Firmware (continued)

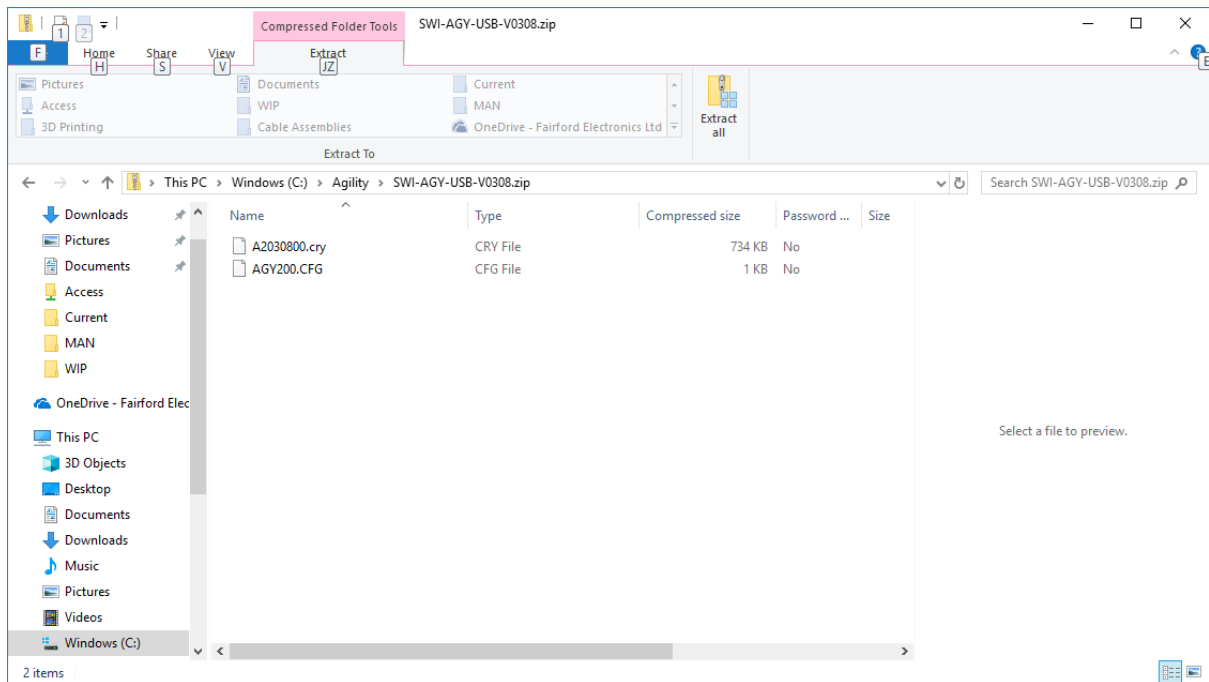

Select all files and copy them to the root directory of the USB flash drive.

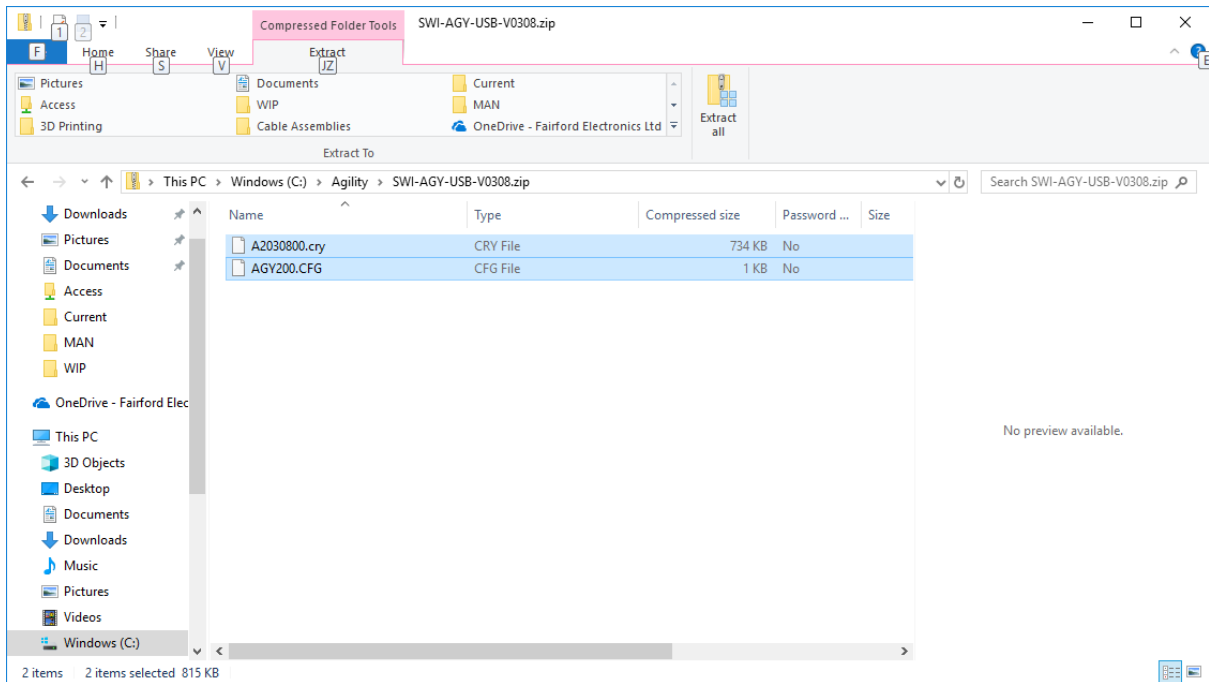

Continued over

Updating Firmware (continued)

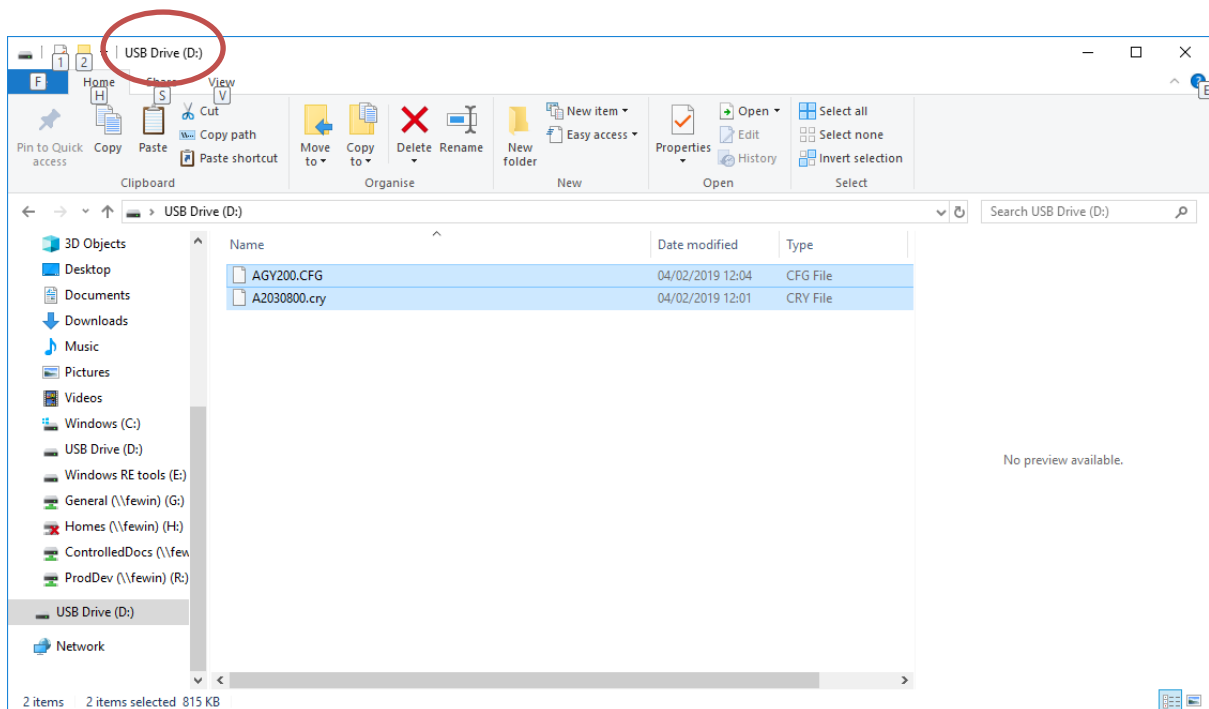

Power down the VMX-agility™ unit and insert the USB stick with the upgrade files into the corresponding socket on the front panel.

Power up the VMX-agility™ unit and the upgrade process will start automatically. The update progress will be shown on the display. During this time, do not remove the USB stick and ensure power is not disconnected.

When the upgrade process is completed VMX-agility™ will reboot. The USB stick may now be removed.

Applications

Motor Suitability and Associated Considerations

The VMX-agility™ soft-starter is based on the “Motortronics UK System” of microprocessor-based optimising soft-starters which have been used world-wide in critical and non-critical systems. Since 1983, Motortronics UK System soft-starters have successfully operated with almost every type of load and environment from the Antarctic to the Jungle. The design has proven to be both reliable and adaptable, and provides a powerful mechanism with which to control fixed-speed induction motors. However, due to the intrinsic differences between electronic and electro-mechanical starting systems, there are a number of simple rules and observations to follow when using the VMX-agility™ soft-starter. This section introduces guidelines for the user and those incorporating the unit as part of their system design.

Suitability - In principle, any induction motor can be started by a soft-starter. Normally, the breakaway torque of the load should be less than the full-load torque of the motor, unless a motor with a high locked rotor torque characteristic is employed. As a quick assessment, any load which has a low or no-load start with a moderate starting time, or which can be started with a star-delta starter, auto transformer or other forms of reduced-voltage starting, can be considered to be a potential application for a soft-starter.

Induction Motor Characteristics - Induction motors are required to provide sufficient torque to accelerate the motor and its load from standstill to full speed and to maintain full speed efficiently at all torque levels up to the design full load torque. Most modern induction motors have characteristics that are wholly suitable for use with soft starters, however, the characteristics vary considerably between different manufacturers and design types. It is important that the motor is capable of providing sufficient torque to drive the load at all speeds between standstill and rated speed, to enable the VMX-agility™ to function properly. It is particularly important that the motor to be soft started does not have a low pull-up or saddle torque otherwise the load may not be accelerated correctly.

The primary function of the soft-starter is to act as a torque-regulating device. It cannot apply a torque greater than that which the motor generates. For this reason, problematic applications for which many different starting methods have been tried but failed, may need analysis of the motor or load performance before a soft-start can be successfully applied.

Rating - For most applications, except high inertia loads, the starting demands and the inertia of the rotating masses are small enough to be insignificant. This means that no special consideration needs to be given to the rating of the soft-starter, other than to ensure that it is equal or marginally greater than the rated voltage and current of the controlled motor.

Alternatively, if the number of poles of the motor and the moments of inertia of the load (J_{load}) and motor rotor (J_{motor}) are known, a soft-starter will be suitable if the figures comply with the criteria given in the bottom row of following table:

Number of Poles	2	4	6	8
Synchronous Speed (rpm) Hz)	3000	1500	1000	750
(J_{load})/(J_{motor}) less than	5	15	20	25

Applications (continued)

Maximum Motor Cable Length

The length of the cable between the output terminals of the starter and the motor should not normally be greater than 100 metres.

Power Factor Correction Capacitors

Power factor correction capacitors applied to a single motor MUST always be connected by a separate contactor placed on the SUPPLY side of the VMX-agility™ soft-start. Capacitors should be switched in after top-of-ramp (full line voltage) is reached and switched out of circuit before a stop is initiated.

It is important that any total system PFC scheme that automatically corrects for a range of inductive loads is not operated in such a way as to leave it heavily over compensated since this might introduce oscillations leading to damaging over-voltages.

Lightly Loaded, Small Motors

Lightly loaded, small-sized (less than 2kW), star connected motors can produce high voltages at the motor terminals when shut down by simply opening the line contactor. As these voltages can damage the soft-starter, it is safer to control the opening of the line contactor with the soft start run relay contacts.

Motors Fitted with Integral Brakes

Motors that include an integral, electrically operated brake, internally connected to the motor input terminals, can only be soft-started when the brake is re-connected to the supply through its own contactor.

Older Motors

The action of the fully-controlled soft-starter introduces harmonic currents and voltages to the motor. It is therefore, important to ensure that the motor employs techniques such as rotor skewing in its construction to suppress the effects of harmonic fluxes and avoid rough starting. This is rarely a problem with modern motors because nearly all motors designed in the last 20 years employ these techniques.

Wound-rotor or Slip-ring Motors

Slip-ring induction motors ALWAYS need some resistance in the rotor circuit to ensure that sufficient rotational torque is generated to overcome any alignment torque, which is present at start-up. The resistance can be safely shorted out in the normal fashion with a contactor controlled by the programmable relay set as 'top-of-ramp' contacts.

Enclosures

Thyristors are not perfect conductors, and the passage of current through them causes heat dissipation in the body of the device, which in turn causes the heatsink temperature to increase. As a rough guide, the heat generated is 1 watt/amp/phase when energy saving, which equates to a dissipation of 30 watts from the heatsink for a line current of 10 amps. Therefore, all cabinets or enclosures that house soft-starters should have adequate ventilation (refer to the Mechanical Installation Procedures, section for more detailed information).

Applications (continued)

EU Compliance with the EMC Directive

When considering the use or fitting of any Soft Starter, users and installers in European countries must comply with the EMC Directive 89/336/EEC. The manufacturer of the soft starter has a statutory obligation to provide a guide for compliance with this directive. For VMX-agility™, this guidance is given in the EMC guide which is A3 of this manual. It is essential that users and installers understand and comply with the requirements described in these sections.

Fuses

Circuit protection fuses should be rated at twice the motor rated current for normal low inertia applications. See also section relating to high inertia loads. Semiconductor fuses are available for the short circuit protection of the thyristors in VMX-agility™. See Electrical Installation section for fuse recommendations.

Rules for Specific Applications

High Inertia Loads

High inertia loads such as centrifugal and axial fans, grinders, flywheel presses, etc., may require a larger size of soft-start than the motor. For example, a 75kW starter may be needed for a 55kW motor. This is necessary due to the extra heat produced by the thyristors due to the extended start times and/or higher over-currents. If very high inertia loads are involved, then an analysis of the starting characteristics should be made. This will require accurate data about the motor speed-torque and speed-current characteristics as well as the load characteristics. For further information, consult your supplier. Consideration must also be given to thermal overload and fuse protection systems when extended start times are involved. This must be as for heavy duty starting, as a standard thermal overload will trip under these conditions. A heavy-duty start thermal overload or an electronic overload with dual settings for start and run is recommended. Modern HRC motor fuses will allow for some overload during the start, but the fuse curve, giving time/current data, will give an indication of suitability for the particular application.

Frequent Starting

High starting frequencies require careful consideration of the soft-start thermal capabilities. In many cases a standard sized VMX-agility™ may be suitable as start times are generally shorter for this type of application. If this is not the case then a larger soft-start may be required (please refer to Motortronics UK for further information).

Soft-Stopping

Soft-stopping can reduce positive surge pressures in pipelines on shutdown. It is necessary to make sure that the ramp-down time is long enough to remove the energy from the fluid before the firing of the thyristors is stopped, otherwise the surge pressure may still be present. Soft-stopping can also be successfully applied to loads such as conveyer belt systems where sensitive items such as bottles are being transported.

Applications (continued)

Reversing Configuration

VMX-agility™ soft-starters used in conjunction with contactor controlled reversing and plug-braked motors show considerable benefits to the user by reducing mechanical and electrical stresses, particularly when utilising the current limited start feature. It is required, with this type of application, to insert a 150 to 350 millisecond delay between the opening of one contactor and the closing of the other, to allow any residual flux in the rotor to die away.

Replacement of Fluid Couplings

Soft-starters can replace fluid couplings yielding benefits of higher efficiency running and lower costs to the user. If the coupling is used to magnify the available breakaway torque, it may be necessary to replace the fitted motor with another of a larger size or one with a high starting torque characteristic before a soft-start can be employed.

Two-speed Motor Applications

Two speed motors, whether Dahlander connected or with dual windings, can be soft started at each speed, provided that the start is initiated when the actual motor speed is less than the synchronous speed for the winding selected. This is particularly important when changing from high to low speeds.

Overhauling Loads

Certain applications can over-speed the motor as part of normal operation. Power flow is then from the motor to the supply. It is important that the optimising is disabled during the over-speed condition and reinserted during normal conditions.

Application Table

The table on the following page shows many common motor applications that suit the VMX-agility™ soft-starter. It lists typical breakaway torque requirements as a percentage of motor full-load torque (FLT). For the most satisfactory soft-start in a given application, the motor should have a full-voltage locked-rotor-torque (LRT) that is at least twice the breakaway torque (E.g. For a reciprocating compressor the FLT is normally in the region of 50% motor LRT). As a general rule, the higher the motor LRT is above the load breakaway torque, the greater the control over the starting process.

Applications (continued)

Applications		
Application	Breakaway Torque (%FLT)	Remarks
Agitator	35	–
Air compressor - rotary, unloaded start	25–35	–
Air compressor - reciprocating, unloaded start	50–100	–
Air compressor - screw type, unloaded start	30	Usually two-pole motor
Ball mill	30–50	Eccentric load, needs high starting torque motor
Carding machine	100	Often high inertia
Centrifuge	50–90	Usually high inertia
Centrifugal fan - dampers closed	10–25	Usually high inertia
Centrifugal fan - dampers open	10–25	Usually high inertia, very long ramp times
Centrifugal blower - valve closed	25–35	–
Centrifugal blower - valve open	30–40	Can have long ramp time
Conveyor - horizontal, unloaded	10–50	–
Conveyor - horizontal, loaded	100–150	–
Conveyor - vertical lifting, unloaded	50–85	–
Conveyor - vertical lifting, loaded	100–175	–
Conveyor - vertical lowering, unloaded	10–40	–
Conveyor - vertical lowering, loaded	10–25	–
Crusher (not rock) - unloaded	25–75	Can be high inertia
Drilling machine - unloaded	10	–
Fan, axial-flow propeller	20–40	–
Feeder - screw	100–175	Needs high starting torque motor
Feeder - vibrating, motor driven	100–150	Needs high starting torque motor
Grinder - unloaded	10–25	Usually high inertia
Hammer mill	20–125	Eccentric load, needs high starting torque motor
Mills - flour etc.	30–50	–
Mixer - dry contents	35–75	–
Mixer - fluid contents	10–40	–
Mixer - plastic contents	75–125	High torque motor offers advantage
Mixer - powder contents	75–125	High torque motor offers advantage
Pelletizers	50–100	–
Press, flywheel	50–150	Needs high starting torque motor
Pump - centrifugal	10–25	Soft stopping useful
Pump - positive displacement, piston type	100–175	Needs high starting torque motor
Pump - vane type, positive displacement	100–150	Needs high starting torque motor
Rolling mill	30–50	–
Saw, band	10–35	–
Saw, circular	25–50	May be high inertia; Plug brake may be useful
Screen, vibrating	30–60	–
Transformers, voltage regulators	Nil	Change firing mode
Tumblers	30–100	Can be eccentric load, may need high torque motor

Applications (continued)

Applications (continued)		
Application	Breakaway Torque (%FLT)	Remarks
Rolling mill	30–50	–
Saw, band	10–35	–
Saw, circular	25–50	May be high inertia; Plug brake may be useful
Screen, vibrating	30–60	–
Transformers, voltage regulators	Nil	Change firing mode
Tumblers	30–100	Can be eccentric load, may need high torque motor

Concepts and principles of fixed-speed induction motor starting and control

Since its invention one hundred years ago, the standard 3-phase induction motor has become one of the most familiar items of industrial equipment ever known. Due to its simplicity of construction, low cost, reliability and relatively high efficiency, it is likely to remain the prime source of mechanical energy for the foreseeable future.

Introduction

Energy conversion, from the electrical supply to rotating mechanical energy, is a characteristic of all motors. To regulate energy flow, most motor circuits require a mechanism to connect and disconnect them from their electrical power source; electro-mechanical switches, known as ‘Contactors’, are the standard means of achieving this control. Even today, more than one hundred years after their introduction, contactor-based systems remain the most widely used method of motor control. Nevertheless, there is a definite trend towards more sophisticated electronic systems of control being applied to fixed-speed motor drives. This section will discuss these newest forms of control - namely, electronic, microprocessor-controlled, optimising soft-starters such as VMX-agility™.



Note: Since there is a wealth of detailed literature available in the technical press, it is not proposed to dwell too heavily on the specifics of realising the electronic control system, but rather, to offer an outline of its various capabilities.

The Induction Motor

In order to appreciate the benefits of using an electronic controller, it is important to have some understanding of the characteristics and limitations of the induction motor and the electro-mechanical systems currently used to control them. The standard, fixed-speed induction motor fulfils two basic requirements:

- To accelerate itself and its load to full speed (or speeds with multi-speed motors)
- To maintain the load at full speed efficiently and effectively over the full range of loadings

Applications (continued)

Due to the constraints of materials and design, it can be difficult to achieve both objectives effectively and economically in one machine. So, how does a motor start in the first place? As mentioned earlier, motors convert electrical energy drawn from the power supply into a mechanical form, usually as a shaft rotating at a speed fixed by the frequency of the supply. The power available from the shaft is equal to the torque (moment) multiplied by the shaft speed (rpm). From an initial value at standstill, the torque alters, up or down, as the machine accelerates, reaching a peak at about two thirds full speed, finally to become zero at synchronous speed. This characteristic means that induction motors always run at slightly less than synchronous speed in order to develop power - the 'slip speed' and, hence the term asynchronous. The following graph is of an induction motor torque/speed curve and illustrates this most important characteristic:

Torque/Speed Curve – Induction Motor

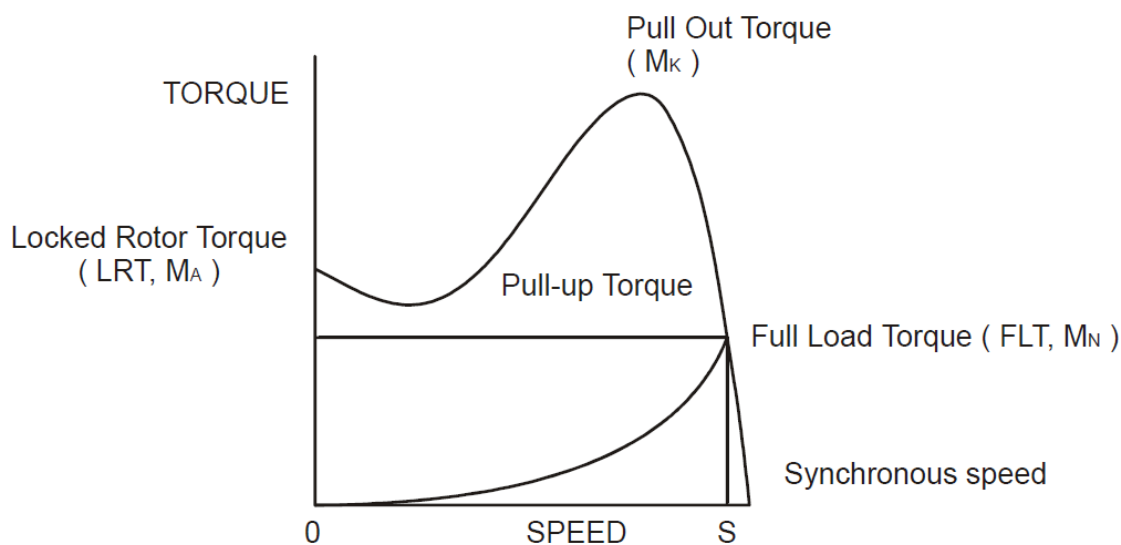

As for each type of motor, so each load coupled to an induction motor has its own speed/torque curve.

Applications (continued)

The Induction Motor (continued)

The acceleration of a motor-load system is caused by the difference between the developed torque (motor) and the absorbed torque (load), and is shown by the shaded area in the next figure:

Torque/Speed Curve – Coupled Load

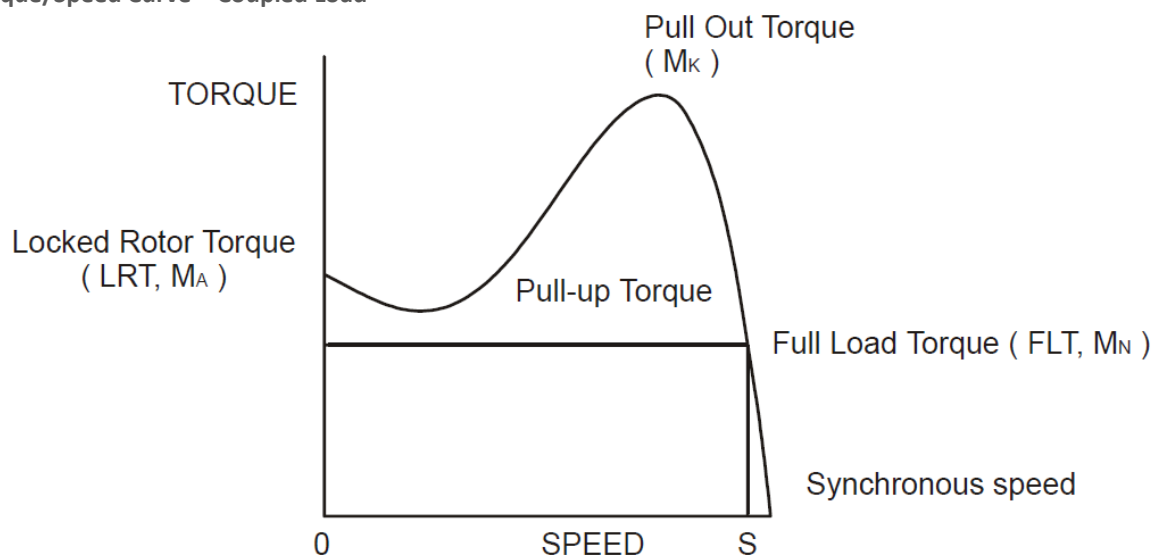

Torque/Speed Curve – Accelerating Torque

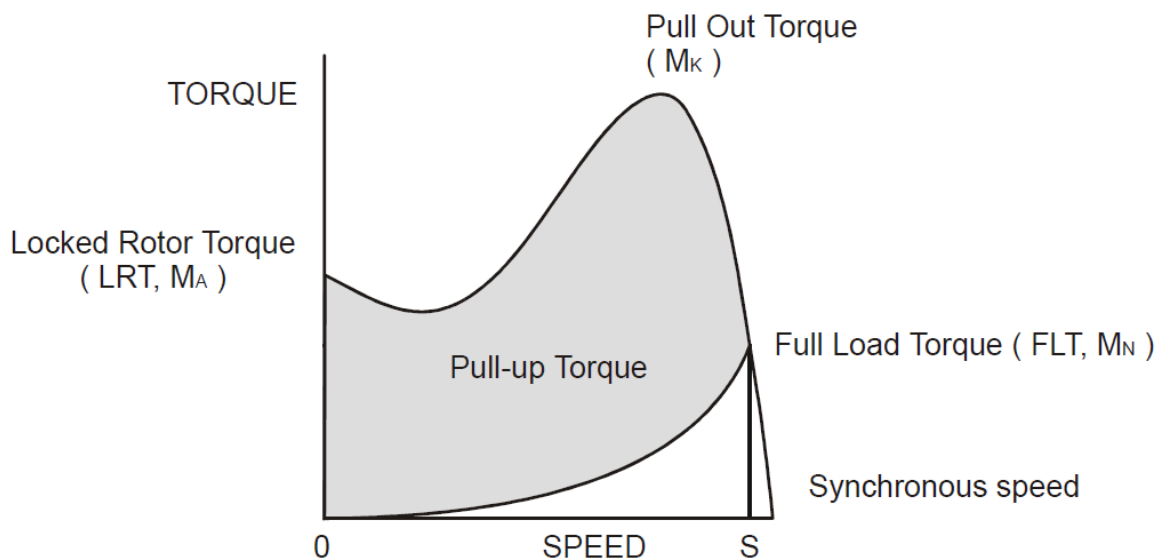

Obviously, the larger the difference, the faster the acceleration and the quicker full speed is reached - and, coincidentally, the greater the stresses experienced by the supply and drive systems during the acceleration process. An "ideal" start would accelerate the load with just sufficient force to reach full speed smoothly in a reasonable time, and with minimum stress to the supply and drive mechanisms.

Applications (continued)

Broadly speaking, the motor speed/torque characteristic is controlled by the rotor resistance - a motor with high rotor resistance can generate its peak torque (pull-out torque) at standstill giving the high break-away torque characteristic, which reduces steadily as the speed increases and becoming zero at synchronous speed. At the other end of the scale, a motor with a very low rotor resistance will produce a low starting torque but will generate its peak torque closer to the synchronous speed. Consequently, this type of motor runs at full power with higher operating efficiency and low slip speed. It is possible to combine the twin requirements of high starting torque and efficient full-speed operation within a single motor by techniques such as double-cage or deep bar design, and this, usually, is the motor characteristic chosen for lifting and hoisting applications.

However, most induction motors are designed to have a “standard” characteristic that provides a compromise between starting torque and operating efficiency. To summarise, an induction motor will only start and accelerate when it produces more torque than the connected load absorbs. This is true for all speeds - including standstill and full speed.

Torque/Speed Curve – High Starting Torque

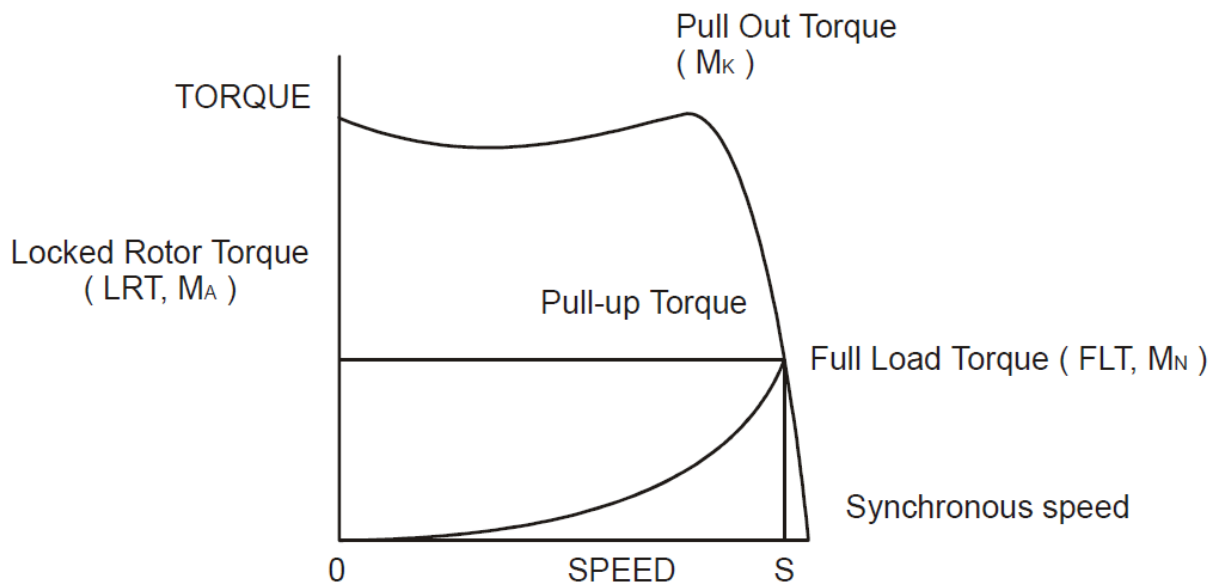

Starting Induction Motors

Starting a de-magnetised induction motor from standstill is a demanding and complex process. At the instant of switching all the energy necessary to magnetise the motor, to provide the acceleration force, and to supply the kinetic energy of the rotor and load, must be present together with the energy to overcome the mechanical and electrical losses. To do so at full supply voltage places considerable stresses on the supply, the motor windings, and the iron cores of the stator and rotor. Excessive acceleration of a rotor when the mechanical load is small can produce torque oscillations in the shaft causing severe wear to transmissions, gears and drives. Excessive acceleration when the load inertia is high such as in centrifugal fans, causes belts to slip in the pulleys, producing rapid wear and early failure.

Applications (continued)

Electro-Mechanical Methods Of Starting

Method A: Direct-on-Line

The most simple means of controlling energy flow to an induction motor is to interrupt the power supply by a single, solenoid operated, 3-phase switch, known as a contactor. Very widely applied, the method is known variously as “direct-on-line”, “across-the-line”, “direct” etc., and is the usual form of control where low cost is the first, and most important, consideration. As a result, it is most often used on small motor sizes (up to approx. - 22kW), or where the supply is strong enough to withstand the inrush and starting current surges without causing unacceptable voltage drops.

The harsh, damaging effects described earlier are all imposed by direct-on-line starting and, as a control method, it is the most destructive of equipment. Its simplicity and apparent low cost, although attractive at first sight, hide large cost penalties in the shape of increased maintenance, reduced transmission equipment life and higher risk of motor failure, particularly when frequent starting and stopping is needed.

In larger sized motors special strengthening is necessary, at higher cost, before they can be safely used with direct-on-line starting. However, the shortcomings of the direct-on-line starter have been recognised ever since motors have been used and alternative systems have been developed over the years to reduce the damaging effects of this form of control.

Method B: Star-Delta and other Reduced Voltage Starting Systems

Reduced voltage starting makes use of the fact that motor torque is proportional to the square of the terminal voltage; the most familiar type of reduced-voltage starter is the star-delta starter. Consisting of three contactors and a time switch (which can be mechanical, pneumatic, electrical or electronic), the star-delta starter changes the motor winding configuration from an initial star connection to a delta as the motor accelerates. The change-over or transition point is controlled by the time switch and is usually arranged to be approximately at 80% of full speed. The effect of starting in star is to alter the voltage across each stator winding to 58% of normal. This reduces the starting torque to a third of locked rotor torque (LRT) with a consequent reduction in starting currents and acceleration forces.

Although an apparent improvement over the direct system, significant disadvantages still remain. The transfer from star to delta momentarily removes the motor from the supply. During this time the motor is under the mechanical influence of the rotating load and, at the instant of disconnection, current will still flow in the rotor bars due to the time delay necessary for the magnetic flux to die away.

Therefore, there is a residual flux “frozen” on the surface of the rotating rotor, which cuts the stator windings, generating a voltage whose frequency depends on the rotor speed. If the load inertia is small, such as in a pump, or if the friction is high, there could be a significant loss of speed during the time the supply is disconnected.

In this case, when the reconnection to delta is made, a large phase differential can exist between the supply and the rotor fluxes. This can give rise to very large current surges (as much or more than full-voltage locked rotor current), together with massive transient torque oscillations, which can peak at levels in the region of fifteen-times full-load torque. Although the effects described are only present for a very short period of time (about one fifth of a second), they are sources of great stress and damage to the whole drive system, and where frequent starting is necessary, invoke high maintenance costs. The current surges, in the form of a very high level short duration “spikes”, are an increasing problem in these days of computer control systems and other “sensitive” electronic equipment. The voltage disturbance on the supply is very difficult to filter out and can cause severe problems, especially when larger motors are involved.

Applications (continued)

There are methods of control, for example, the Wauchope starter, which eliminate or reduce the reconnection transients. However, such starters are expensive and have reliability implications; for these reasons they are not widely applied.

The star-delta starter also has disadvantages due to the restricted starting torque available (if you need 40% LRT to break-away, you can only increase the motor size, or revert to direct-on-line). Combined with the severe effects of the re-switching surges, and the additional costs of bringing six conductors from the motor to the starter instead of only three, star-delta only offers an imperfect solution to the problem of starting the induction motor.

Method C: Primary Resistance Starter

It has long been recognised that the transition step in the star-delta system was a source of problems such as welded contactors, sheared drive shafts etc., and for many years a method of stepless control has been available in the form of the primary resistance starter. This type of controller inserts a resistance in one, or more often in each, of the phase connections to the stator at start-up, after which it is progressively reduced and shorted out at the end of the acceleration process. Frequently, the resistances are movable blades that are gradually inserted into an electrolyte liquid. The mechanism is usually large and expensive, both to purchase and to maintain, and considerable heat is created by the passage of current through the electrolyte resistor. This limits the starting frequency (because the electrolyte has to condense back to liquid before a new start can proceed), and these restrictions prevent this starter from being a popular option when selecting a control system. However, it has the distinction of being the smoothest and least stressful method of accelerating an induction motor and its load.

Method D: Other Electro-Mechanical Systems

Other control methods such as auto-transformer starting (popular in North America), primary reactance starting etc., are employed to a greater or lesser extent, to compensate for some of the disadvantages of each type of starter discussed. Nevertheless, the fundamental problems of electro-mechanical starters remain, and it is only in the last decade or two that their dominance has been challenged by the introduction of power semiconductors controlled by electronics.

The Semiconductor Motor Controller

During the 1950's, much effort was put into the development of a four-layer transistor device which had the power to switch large currents at high voltages when triggered by a very small pulse of current. This device became known as the silicon controlled rectifier (SCR), or in Europe, the 'Thyristor'; it is the basis on which all soft starting systems are built. The characteristic of most interest is the ability of the thyristor to switch rapidly (in about 5 millionths of a second) from "OFF" to "ON" when pulsed, and to remain "ON" until the current through the device falls to zero, - which conveniently, happens at the end of each half-cycle in alternating current supplies.

By controlling the switch-on point of a thyristor relative to the voltage zero crossing in each half wave of an alternating current, it is possible to regulate the energy passing through the device. The closer the turn-on point is to the voltage zero crossing point, the longer the energy is allowed to flow during the half-cycle. Conversely, delaying the turn-on point reduces the time for the energy to flow. Putting two thyristors back-to-back (or anti-parallel) in each of the phase connections to a motor, and by precisely controlling their turn-on points, an electronic soft starter continuously adjusts the passage of energy from the supply so that it is just sufficient for the motor to perform satisfactorily.

So, for instance, by starting with a large delay to the turn on point in each half cycle, and progressively reducing it over a selected time period, the voltage applied to the motor starts from a relatively low value and increases to full voltage. Due to the motor torque being proportional to the square of the applied voltage, the starting torque follows the same pattern giving the characteristic smooth, stepless start of the soft-starter.

Applications (continued)

Running Induction Motors

Once a start has been completed the motor operating efficiency becomes of interest. When working at or near full load, the typical 3-phase induction motor is relatively efficient, readily achieving efficiencies of 85% to 95%. However, as shown below, motor efficiency falls dramatically when the load falls to less than 50% of rated output.

In fact, very few motors actually experience consistent fully rated operation, the vast majority operate at much lower loads due to either over-sizing (a very frequent situation), or natural load variations. For Fan and Pumping applications, the affinity laws will allow the inverter drive to show very considerable energy savings over virtually all other methods of control through varying the speed of the motor in response to changes in load. Where motor speeds cannot be varied, an optimising version of semiconductor motor controller, such as VMX-agility™ will also produce energy savings in lightly loaded motors. Less sophisticated systems of soft-starter remain at full conduction and the motor then behaves as if it were connected directly to the mains supply. However, at light loads and mains voltages, induction motors always have excess magnetic flux, and efficiency loss and power factor degradation result. By detecting the load at any instant, and adjusting the motor terminal voltage accordingly, it is possible to save some of the excitation energy and load loss, and improve motor power factor when the motor is running inefficiently at light loads.

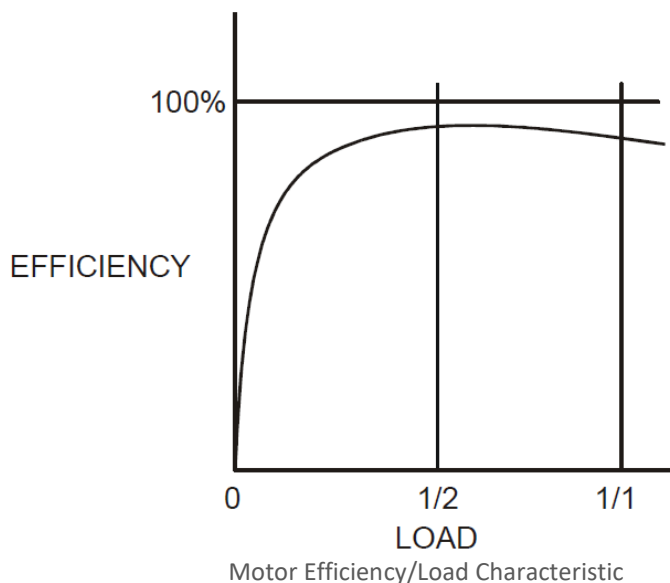

Applications (continued)

All VMX-agility™ soft-starters are microprocessor controlled, and this gives them a number of advantages. Firstly, there are no adjustments to be made for the energy saving function: all calculations necessary to find the best degree of phase-back of the thyristors for any load condition is made by the microprocessor. Secondly, the start always synchronises with the supply voltage and a special structure of turn-on pulses virtually eliminates the inrush currents normally associated with motor start-up; this happens every time. Lastly, there is the absolutely stepless starting process, found only with the primary resistance or reactance electromechanical starters - but without the wasted energy, and with the opportunity to control the maximum current allowed to flow during the starting process. Other features such as soft stopping are included to give considerable control over all modes of induction motor operation.

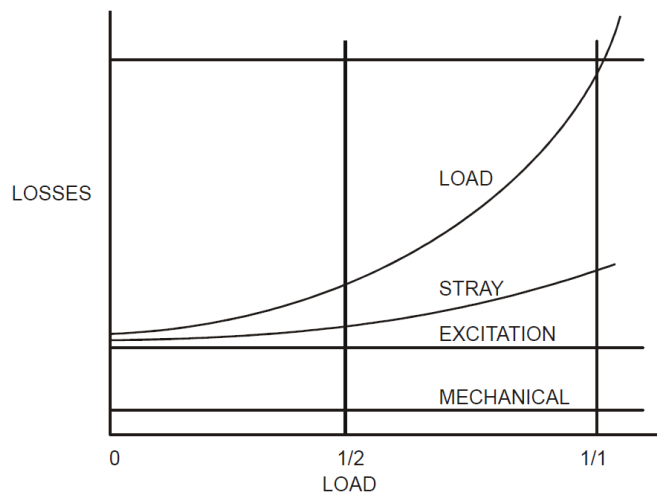

Motor Efficiency/Loss Characteristic

Reliability Considerations

An aspect of electronic controllers for induction motors which is of increasing concern is that of reliability. There is little point in installing an expensive item of electronic equipment to save potentially considerable amounts of money if the device is unreliable to the point that vital processes are constantly interrupted.

There are electronic products in the market place which appear to offer soft starting cheaply. They almost always rely on less advantageous technologies such as analogue control, or half-control, where one of the two thyristors in each phase is replaced with a diode. There are systems which only control the energy flow in one phase while the other two are directly connected. Owing to the variable quality and performance of many so-called inverters and soft-starters available to the unsuspecting purchaser, international standards for these products have been developed.

So far, IEC 60947-4-2 - 'AC Semiconductor Motor Controllers and Starters' defines the soft starter in every important respect, including thermal and overload performance as well as electromagnetic compatibility. By ensuring that any motor controller equipment purchased conforms to IEC 60947-4-2, a user should be reasonably safeguarded from shoddy or inadequate products when specifying equipment for future installations. A particular advantage of the use of the optimising soft starter is its impact on the maintenance requirements of associated electro-mechanical equipment. Optimising lowers the surface temperature of the motor by reducing the losses within the motor. This prolongs the motor life - and reduces heating of the surrounding atmosphere in the process. If the atmosphere is subject to air conditioning, reducing the heat input will reduce the air conditioning costs. Reduced starting and running currents reduces cable losses and, contactor

Applications (continued)

switching operations are carried out under the most advantageous conditions. No current flows on switch-on since all switching is carried out by the thyristors - virtually eliminating the need for contact replacement.

Indeed, there are a growing number of installations where contactors are no longer employed, being replaced by controllable circuit breakers or isolators instead.

In summary, electronic controllers for most fixed-speed applications are opening new ways of increasing the efficient operation of induction motors, as well as offering significant benefits in control. Intending users need to ensure themselves of the quality and performance of any products they expect to fit and this can be reasonably expected if compliance with the appropriate IEC standards is demanded.

Accessory Installation

Power Supply VMX-AGY-020 and VMX-AGY-021

VMX-AGY-020/021 are dedicated mains power supply for the VMX-agility™ soft start. In addition to allowing for mains control voltage operation, the power supply also allows for mains voltage digital control (D1/D2).

Fitting

Ensure terminals 24V, 0V, COM, D1 and D2 are fully open before installing power supply as shown below:

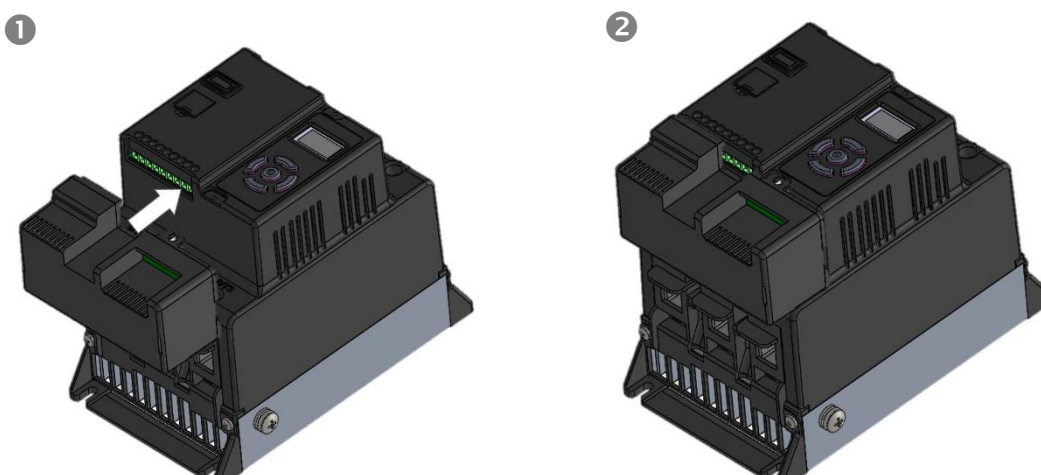

Tighten terminals 24V, 0V, COM, D1 and D2

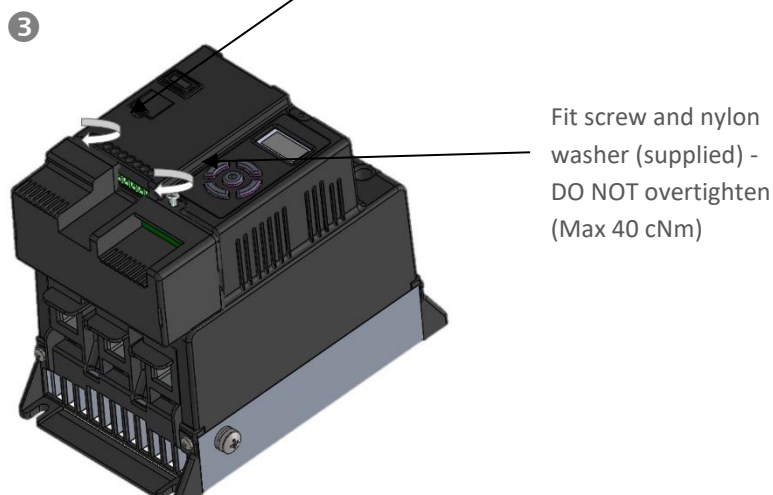

Fit screw and nylon washer (supplied) - DO NOT overtighten (Max 40 cNm)



When the VMX-AGY-020/021 installation is complete, control supply, D1 and D2 are provided on the power supply rather than the VMX-agility™ main unit.

Accessories (continued)

Connections

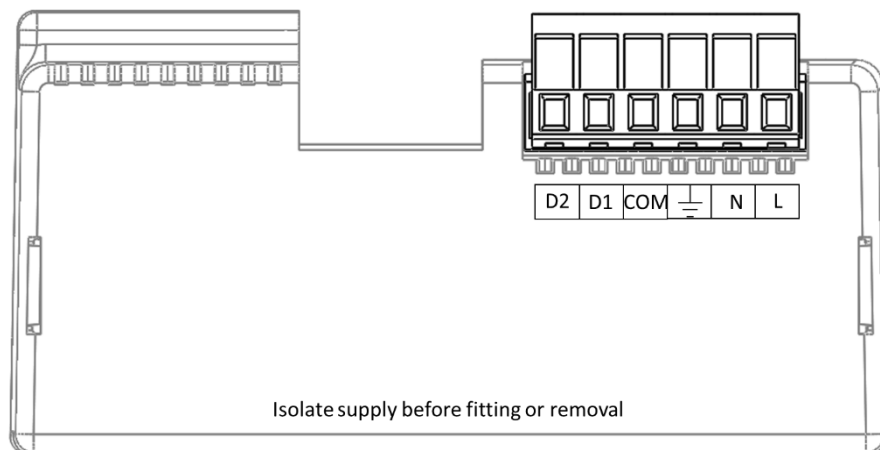

Control Terminal

Terminal	Description	Function Selectable	Note
24Vdc	Control Supply +Us	No	
0V	Control Supply -Us	No	
COM	Digital Inputs Common	No	
D1	Digital Input 1	No	#1
D2	Digital Input 2	Yes	#1
13/14	Main Contactor Control (Run Relay)	No	#2
21/22	Fault relay	Yes	#2

Functions

#1 The voltage applied to the digital inputs D1 and D2 must be the same as the supply voltage

#2 230Vac, 1A, AC15. 30Vdc, 0.5A resistive

Accessories (continued)

3-Wire Control Using VMX-AGY-020/021

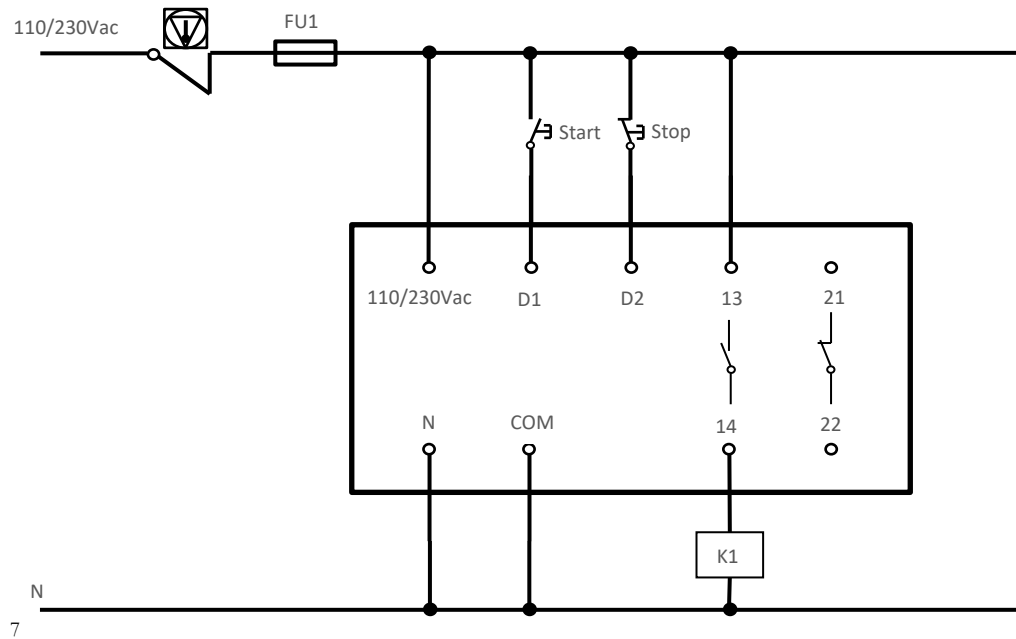

2-Wire Control Using VMX-AGY-020/021

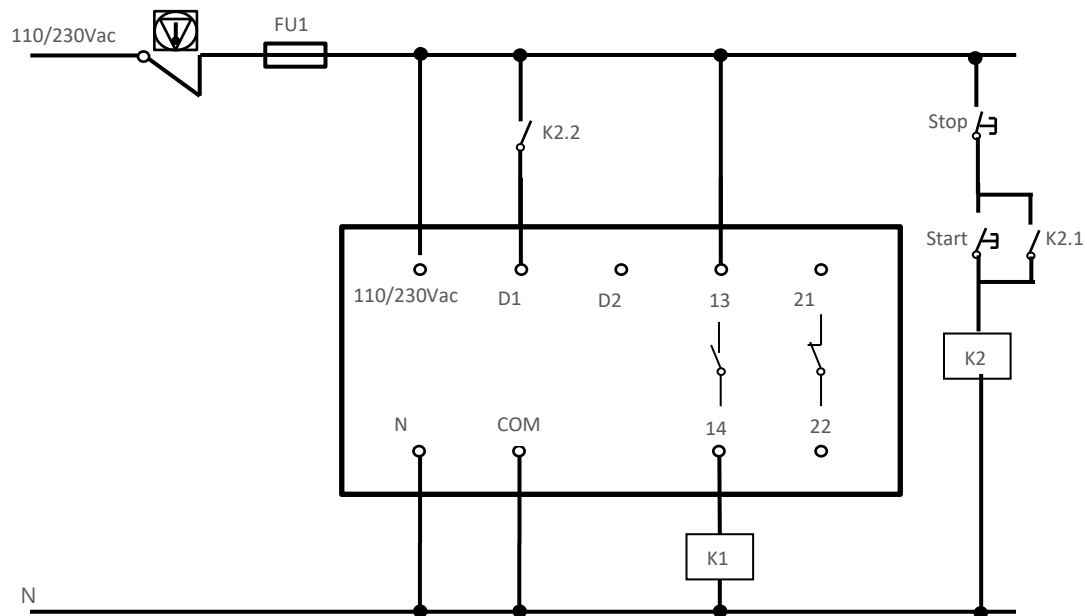

Accessories (continued)

Fan (VMX-AGY-030)

VMX-AGY-030 increases the number of starts to 40/hour. The fan operates automatically during a soft start or soft stop and will continue to run if the heatsink temperature is $> 45^{\circ}\text{C}$. The fan stops when the heatsink temperature has fallen below 40°C .

Fitting

Step 1. Remove screw (x1) and retain

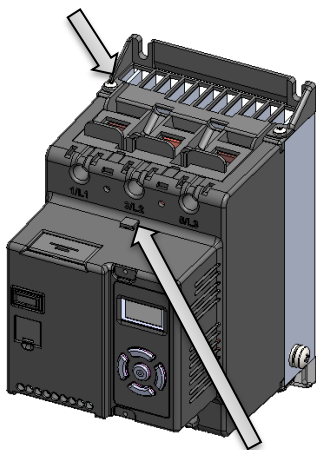

Step 2. Remove blanking plug (x1)

Step 3. Fit fan as shown

Step 4. Replace screw (x1)

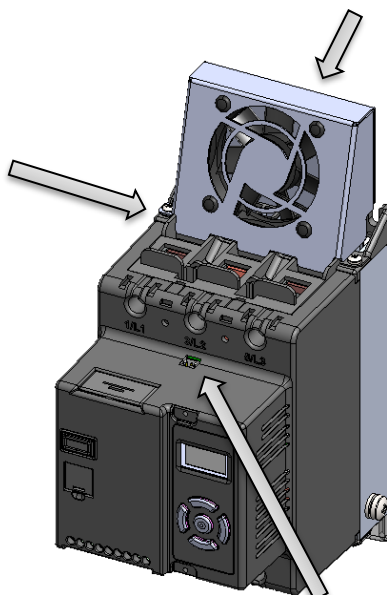

Step 5. Fit flying lead from fan into socket

Accessories (continued)

Fan (VMX-AGY-031)

VMX-AGY-031 is designed for models VMX-AGY-201 to VMX-AGY-209. It increases the number of start/stop cycles per hour (see table below). The fan operates automatically during a soft start or soft stop and will continue to run if the heatsink temperature is $> 45^{\circ}\text{C}$. The fan stops when the heatsink temperature has fallen below 40°C .

VMX-Agility model	Maximum duty cycle F-S with optional fan fitted
VMX-AGY-203	90-40 (40 cycles per hour)
VMX-AGY-205	90-30 (30 cycles per hour)
VMX-AGY-207	90-20 (20 cycles per hour)
VMX-AGY-209	90-10 (10 cycles per hour)

Fitting

Step 1. Position the assembly at the top on the VMX-agility unit

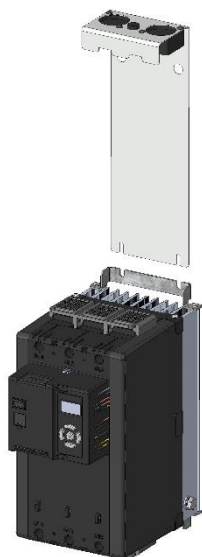

Step 2. Loosen the two lower mounting screws (2a) and slide the fan assembly downward between the mounting bracket and the heatsink fins (2b)

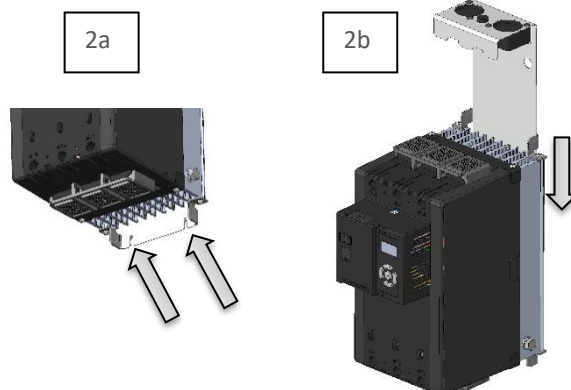

Step 3. When the fan assembly is fully home and the lower plate of the assembly has engaged with the lower mounting screws, re-tighten the mounting screws fully



Step 4. Remove the blanking plug and insert the flying lead from the fan assembly into the socket as indicated below

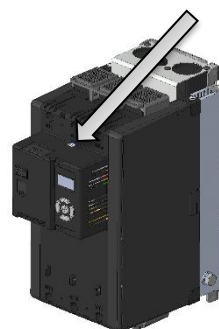

Accessories (continued)

Remote Keypad (VMX-AGY-010)

The remote keypad (VMX-AGY-010) can be used to control, monitor and program up to 32 VMX-agility™ soft starters.

The unit is powered from the host VMX-agility™ and requires an Ethernet cable for communication (Modbus RTU).



As the remote keypad acts as the Modbus master, no additional master units must be placed within the network. Failure to observe this may lead to erratic behaviour, network failure and/or equipment damage.



Network Connection

For a configuration where there is only one VMX-agility™ unit (one-to-one), the remote and main unit can be directly cabled. See diagram below:

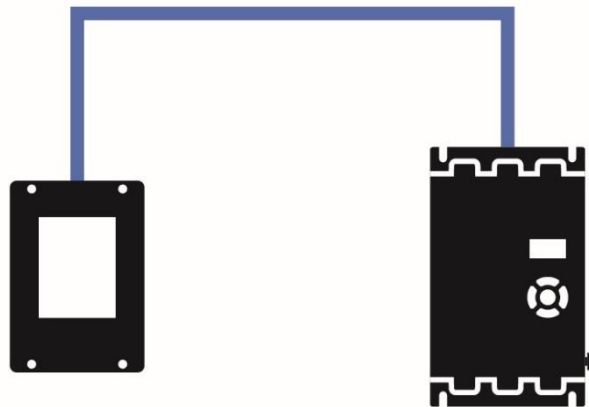

Keypad power must be enabled on the VMX-agility™ starter (see below)

Enabling Keypad Power: Scroll to DEVICE menu → KEYPAD menu → KEYPAD PWR = ON

Keypad Connection and Operation

For multiple base units connected to the keypad, the use of VMX-SGY-011, CBL-036 and CBL-035 (terminator) is highly recommended. See diagram below.

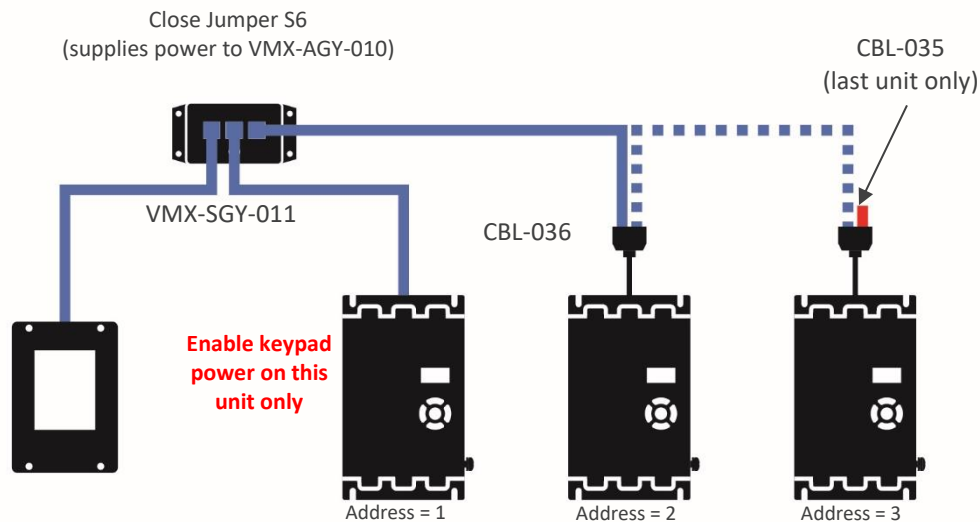

The VMX-agility™ units must have: a unique Modbus address on each unit and identical Parity/Baud rate values on each unit

Operation

Once connected to the VMX-agility™ host unit/s, menu structures and programming are the same as detailed in the VMX-agility™ manuals MAN-AGY-001 and MAN-AGY-002 (both may be downloaded from www.motortronics-uk.co.uk).

However, specific steps must be taken to connect the Remote Keypad to one or more VMX-agility™ host units.

Initial Power-Up

If the host VMX-agility™ unit/s and the remote keypad have the default Modbus transmission parameters set, and the host unit is powered and has keypad power set to 'on', the keypad will automatically communicate with the host. The following status screen will be seen:

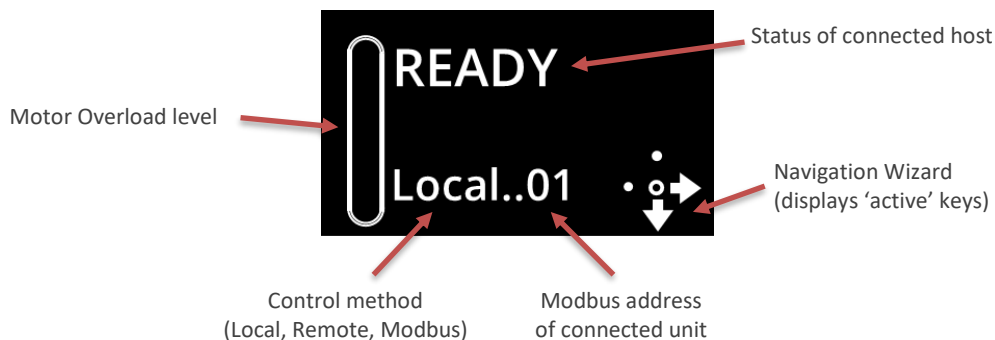

Keypad Connection and Operation (continued)

If any of the Modbus communication parameters are dissimilar on the host unit or remote keypad, communication will not be established. The keypad will display the following screen:

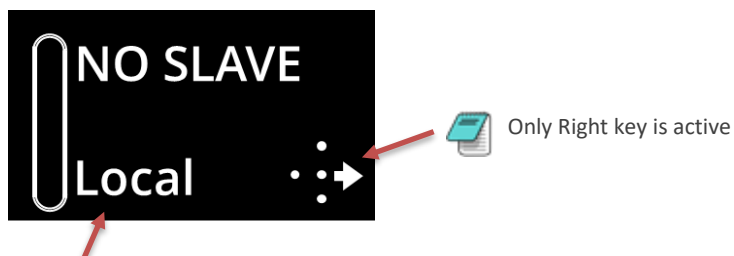

May show: Local, Remote or Modbus

By pressing the Right key, the user will be taken directly to the Modbus address selection menu:

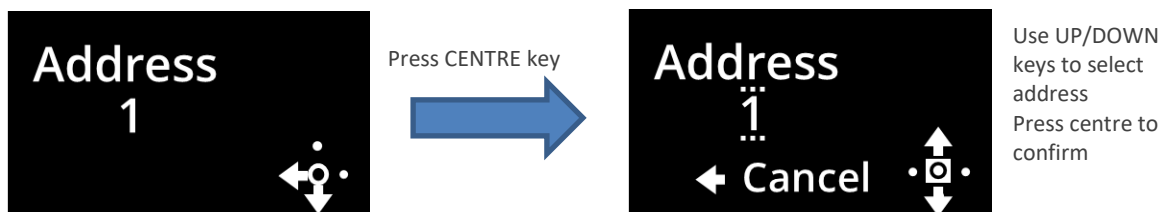

If the selected Modbus address is valid, the status screen is displayed:

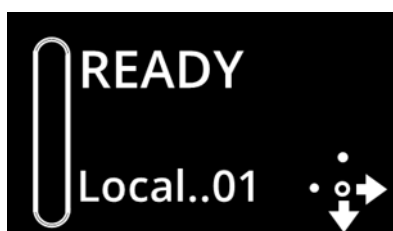

Selecting Units To Monitor/Configure

When the Remote Keypad is attached to multiple VMX-agility™ units on the Modbus network, the user can switch between each unit by using the following method.

 To simplify this selection process it is recommended that the host VMX-agility™ units are configured with consecutive Modbus addresses

(continued over)

Keypad Connection and Operation (continued)

Procedure:

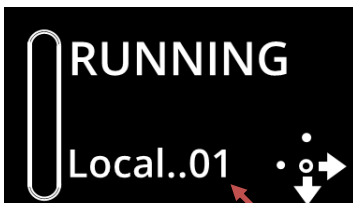

Modbus address
of connected unit

1. Press the 'Right' key
2. Address selection screen will be shown

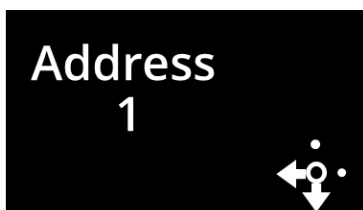

3. Press the 'Centre' key. Display will change mode

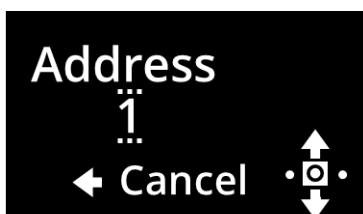

4. Use 'Up' or 'Down' keys to change address to the desired number (VMX-agility™ address). Press the 'Centre' key to confirm
5. Remote display will return to the Status screen and display the new address

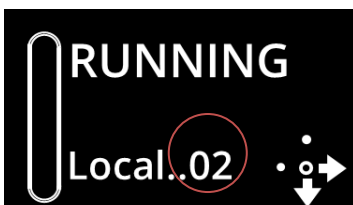

Keypad Installation

Mounting

Fix the unit to a flat, vertical surface using the mounting holes in the keypad enclosure.

- The orientation of the unit has the 'TOP' uppermost
- The location allows adequate front access
- The screen can be viewed

Do not install other equipment that generates significant heat close to the keypad.

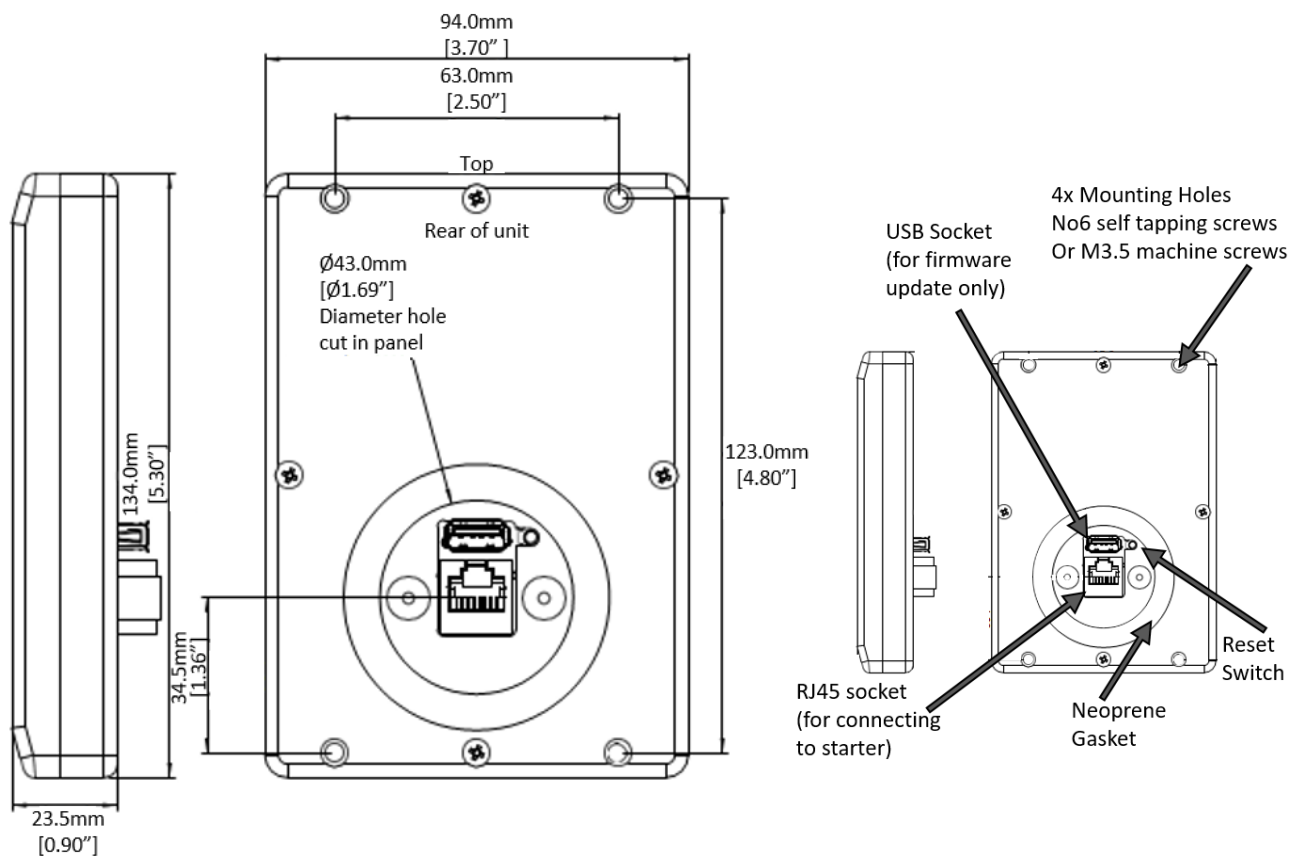

Note: The host units and Keypad must have the same firmware version.

Sizing Guide

agility				
	Typical Applications	Standard Duty	Medium Duty	Heavy Duty
		<p><i>Step 1 - Select the application from the list and follow that column down.</i></p>	Agitator Compressor - Rotary Vane Compressor - Unloaded Conveyor - Unloaded Bow Thruster - Zero Pitch Fan - Low Inertia or <85A Feeder - Screw Lathe Machines Mixer - Unloaded Moulding Machine Plastic and Textile Machines Pump - Submersible Pump - Submersible - Centrifugal Pump - Submersible - Rotodynamic Saw - Band Transformers Voltage Regulators	Compressor - Centrifugal Compressor - Reciprocating Compressor - Rotary Screw Ball Mill Bow Thruster - Loaded Conveyor - Loaded Grinder Hammer Mill Mills - flour etc. Mixer - Loaded Pelletizers Press, Flywheel Positive Displacement Pump - Reciprocating Positive Displacement Pump - Rotary Pump Jack Rolling Mill Roots Blower Saw - Circular Screen - Vibrating Tumblers
<p><i>Step 2 - Confirm the rated starting capability of the soft start against the application.</i></p>	Trip Class Rated Starting Capability Max Starts per Hour with Optional Cooling Fan	Trip Class 10 3x Motor Current - 23secs 3.5x Motor Current - 17secs 5 starts/hour 40 starts/hour	Trip Class 20 4x Motor Current - 19secs 5 starts/hour 40 starts/hour	Trip Class 30 4x Motor Current - 29secs 5 starts/hour 40 starts/hour
<p><i>Step 3 - Consider the operating environment and make the model selection on a higher amp rating.</i></p>	Height Above Sea Level Operating Temperature Increased Starts per Hour	Standard operating height is 1000m, for every 100m increase motor Amps/kW by 1%, up to 2000m. Example: For a 20A motor at 1500m make model selection based on 21A (5% higher)		
		Standard operating temperature is 40degC, for every 1degC above, increase motor Amps/kW by 2%, up to 60degC. Example: For a 20A motor at 50degC make model selection based on 24A (20% higher)		
		Fit optional fan to increase maximum up to 40 starts per hour.		

Sizing Guide (continued)



	Motor Rating										Select Model 5 starts/hour @ 40°C	Select Model 5 starts/hour @ 40°C	Select Model 5 starts/hour @ 40°C
	I _e A	kW			FLA A	Hp							
		230V	400V	500V		200V	208V	220-240V	440-480V	550-600V			
Step 4 - Select your motor Voltage and Horsepower/kW and select model.	17	4	7.5	7.5	17	3	5	5	10	15	AGY-101	AGY-103	AGY-105
	22	5.5	11	11	22	5	5	7.5	15	20	AGY-103	AGY-105	AGY-107
	29	7.5	15	15	27	7.5	7.5	7.5	20	25	AGY-105	AGY-107	AGY-109
	35	7.5	18.5	22	34	10	10	10	25	30	AGY-107	AGY-109	AGY-111
	41	11	22	22	41	10	10	10	30	40	AGY-109	AGY-111	AGY-113
	55	15	30	37	52	15	15	15	40	50	AGY-111	AGY-113	AGY-201
	66	18.5	37	45	65	20	20	20	50	60	AGY-113	AGY-201	AGY-203
	80	22	45	55	77	20	25	25	60	75	AGY-201	AGY-203	AGY-205
	106	30	55	75	100	30	30	30	75	100	AGY-203	AGY-205	AGY-207
	132	37	75	90	125	40	40	40	100	125	AGY-205	AGY-207	AGY-209
	160	45	90	110	156	50	50	60	125	150	AGY-207	AGY-209	AGY-301
	195	55	110	132	192	60	60	60	150	200	AGY-209	AGY-301	AGY-303
	242	75	132	160	242	75	75	75	200	250	AGY-301	AGY-303	AGY-305
	302	90	160	200	302	100	100	100	250	300	AGY-303	AGY-305	-
	361	110	200	250	361	125	125	150	300	350	AGY-305	-	-

Key to Part Numbers

VMX-AGY-101-6-XX

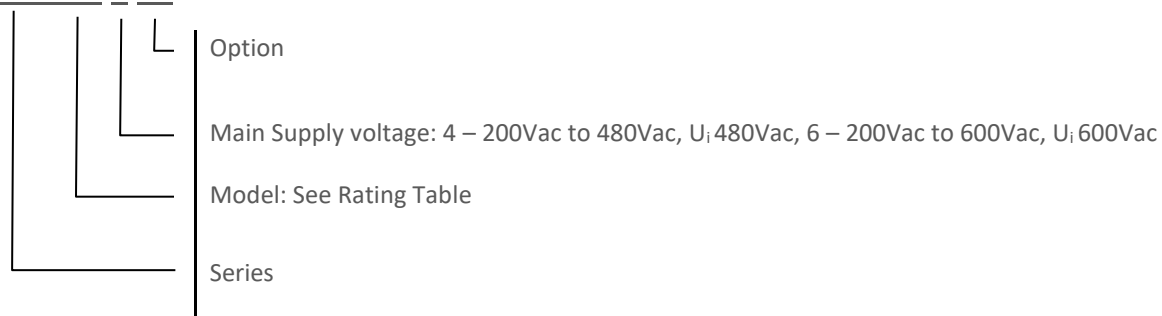

Electric current, Danger to life!

Only skilled or instructed persons may carry out the operations.

Lebensgefahr durch Strom!

Nur Elektrofachkräfte und elektrotechnisch unterwiesene Personen dürfen die im Folgenden beschriebenen Arbeiten ausführen.

Tension électrique dangereuse!

Seules les personnes qualifiées et averties doivent exécuter les travaux ci-après.

¡Corriente eléctrica! ¡Peligro de muerte!

El trabajo a continuación descrito debe ser realizado por personas cualificadas y advertidas.

Tensione elettrica: Pericolo di morte!

Solo persone abilitate e qualificate possono eseguire le operazioni di seguito riportate.

触电危险!

只允许专业人员和受过专业训练的人员进行下列工作。

Электрический ток! Опасно для жизни!

Только специалисты или проинструктированные лица могут выполнять следующие операции.

Levensgevaar door elektrische stroom!

Uitsluitend deskundigen in elektriciteit en elektrotechnisch geïnstrueerde personen is het toegestaan, de navolgend beschreven werkzaamheden uit te voeren.

Livsfare på grund af elektrisk strøm!

Kun uddannede el-installatører og personer der er instruerede i elektrotekniske arbejdsopgaver, må udføre de nedenfor anførte arbejder.

Προσοχή, κίνδυνος ηλεκτροπληξίας!

Οι εργασίες που αναφέρονται στη συνέχεια θα πρέπει να εκτελούνται μόνο από ηλεκτρολόγους και ηλεκροτεχνίτες.

Perigo de vida devido a corrente eléctrica!

Apenas electricistas e pessoas com formação electrotécnica podem executar os trabalhos que a seguir se descrevem.

Livsfara genom elektrisk ström!

Endast utbildade elektriker och personer som undervisats i elektroteknik får utföra de arbeten som beskrivs nedan.

Hengenvaarallinen jännite!

Vain pätevät sähköasentajat ja opastusta saaneet henkilöt saavat suorittaa seuraavat työt.

Nebezpečí úrazu elektrickým proudem!

Niže uvedené práce smějí provádět pouze osoby s elektrotechnickým vzděláním.

Eluhtlik! Elektrilöögiolt!

Järgnevalt kirjeldatud töid tohib teostada ainult elektriala spetsialist või elektrotehnilise instrueerimise läbinud personal.

Életveszély az elektromos áram révén!

Csak elektromos szakemberek és elektrotechnikában képzett személyek végezhetik el a következőkben leírt munkákat.

Elektriskā strāva apdraud dzīvību!

Tālāk aprakstītos darbus drīkst veikt tikai elektrospeciālisti un darbam ar elektrotehnikām iekārtām instruetās personas!

Porażenie prądem elektrycznym stanowi zagrożenie dla życia!

Opisane poniżej prace mogą przeprowadzać tylko wykwalifikowani elektrycy oraz osoby odpowiednio poinstruowane w zakresie elektrotechniki.

Livsfara genom elektrisk ström!

Endast utbildade elektriker och personer som undervisats i elektroteknik får utföra de arbeten som beskrivs nedan.

Hengenvaarallinen jännite!

Vain pätevät sähköasentajat ja opastusta saaneet henkilöt saavat suorittaa seuraavat työt.

Nebezpečí úrazu elektrickým proudem!

Niže uvedené práce smějí provádět pouze osoby s elektrotechnickým vzděláním.

Eluhtlik! Elektrilöögiolt!

Järgnevalt kirjeldatud töid tohib teostada ainult elektriala spetsialist või elektrotehnilise instrueerimise läbinud personal.

Életveszély az elektromos áram révén!

Csak elektromos szakemberek és elektrotechnikában képzett személyek végezhetik el a következőkben leírt munkákat.

Elektriskā strāva apdraud dzīvību!

Tālāk aprakstītos darbus drīkst veikt tikai elektrospeciālisti un darbam ar elektrotehnikām iekārtām instruetās personas!

Pavojus gvybei dėl elektros srovės!

Tik elektrikai ir elektrotechnikos specialistai gali atlikti žemiau aprašytus darbus.

Porażenie prądem elektrycznym stanowi zagrożenie dla życia!

Opisane poniżej prace mogą przeprowadzać tylko wykwalifikowani elektrycy oraz osoby odpowiednio poinstruowane w zakresie elektrotechniki.

Življenjska nevarnost zaradi električnega toka!

Spodaj opisana dela smejo izvajati samo elektrostrokovnjaki in elektrotehnično poučene osebe.

Nebezpečnostv ohrozenia života elektrickým prúdom!

Práce, ktoré sú nižšie opísané, smú vykonávať iba elektroodborníci a osoby s elektrotechnickým vzdelaním.

Опасност за живота от электрически ток!

Операциите, описани в следващите раздели, могат да се извършват само от специалисти-електротехници и инструктиран електротехнически персонал.

Atenție! Pericol electric!

Toate lucrările descrise trebuie efectuate numai de personal de specialitate calificat și de persoane cu cunoștințe profunde în electrotehnică.

Življenjska nevarnost zaradi električnega toka!

Spodaj opisana dela smejo izvajati samo elektrostrokovnjaki in elektrotehnično poučene osebe.

Nebezpečnostv ohrozenia života elektrickým prúdom!

Práce, ktoré sú nižšie opísané, smú vykonávať iba elektroodborníci a osoby s elektrotechnickým vzdelaním.

Опасност за живота от электрически ток!

Операциите, описани в следващите раздели, могат да се извършват само от специалисти-електротехници и инструктиран

Atenție! Pericol electric!

Toate lucrările descrise trebuie efectuate numai de personal de specialitate calificat și de persoane cu cunoștințe profunde în electrotehnică.

Pavojus gvybei dėl elektros srovės!

Tik elektrikai ir elektrotechnikos specialistai gali atlikti žemiau aprašytus darbus.



SCATTERGOOD & JOHNSON LTD

ELECTRICAL ENGINEERING & FLUID CONTROL DISTRIBUTORS

Est.1899

At Scattergood & Johnson Ltd, we pride ourselves on being a technical distributor to specialist industries.

Working with a range of quality product suppliers across a number of specialist markets, we are not your average 'box shifter' - we are your technical and supply chain partner.

We fully support every product we sell - for free! Our internal team and external sales engineers can answer any product or application question, no matter the complexity.

Backing up this technical ability is a range of 50,000+ products available from stock for nationwide next day delivery (same day if required!), or you can collect what you need from any of our trade counters around the UK.

Select your specialist interest below to learn more about how we can help.

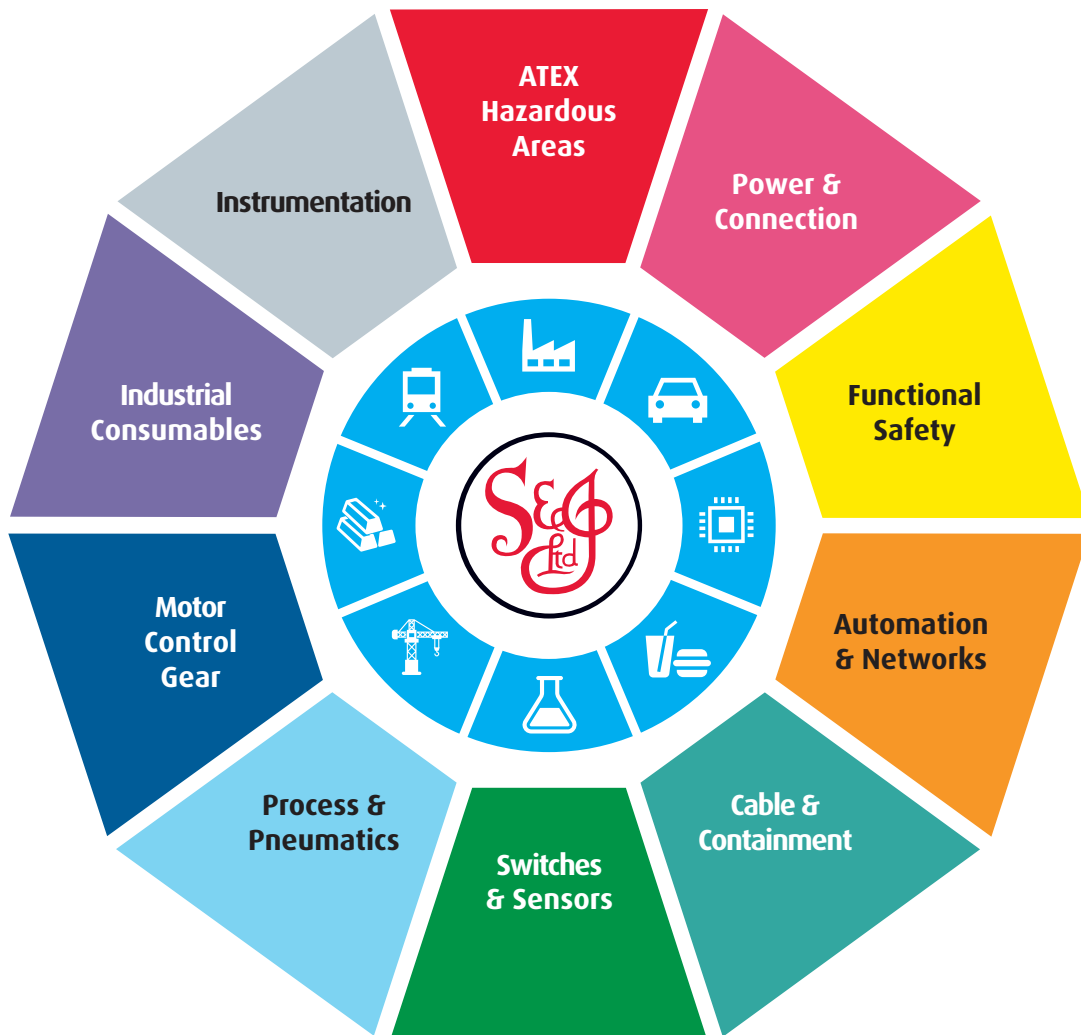

Online, In Branch and On the Road - Scattergood & Johnson Ltd, there when you need us.

www.scatts.co.uk