

VMX-synergy™



MOTORTRONICS
Solid State AC Motor Control

Quick Start Guide



CONFORMS
TO STD UL 508
CSA 22.2
No. 14

Redefining Motor Control

VMX-synergy™

The original pioneers of soft start technology, Motortronics have been at the forefront of motor control innovation since the 1970's. Motortronics have manufactured and supplied over 1 million products into the market place and are recognised as the reference point for many control solution providers worldwide.

In 2009, the need for a new technology that bridged the gap between drive technology and soft start was recognised and the development process began for VMX-synergy™, a new form of motor control that met the needs of those requiring the functionality of a drive in a fixed speed application. The key aspects of a drive (energy saving and communications) as well as original features of a soft start including internal bypass and lower cost, meant the base design was enhanced even further.

iERS (intelligent Energy Recovery System) is Motortronics patented energy saving system with a combined internal bypass to save energy on lightly loaded motors. iERS reduces the voltage and current supplied to lightly loaded motors to only allow the motor to consume the exact amount of energy required to maintain the speed at that load.

When the motor is at full load the internal bypass closes, this reduces the losses produced by the control element. This combined approach enables iERS to save more energy in more applications than any other competing technology.

iERS has been market proven over the past 10 years and has now reached its latest development realising even greater savings. Applications such as compressors, refrigerators, pump jacks, moulding machines and chillers can typically see savings of around 8-40% of total energy consumption when lightly loaded.

With size and cabinet capacity an ever increasing focus, Motortronics developed the world's smallest power to size ratio motor controller. VMX-synergy™ utilised Motortronics's globally renowned Automatic Setup feature to programme the unit to each individual application using only a 8 button process. Since then it has removed buttons and uses touch screen technology bringing the user interface to even greater management levels.

With full motor overload protection as well as full data logging, upgradeable software in the field and extensive input/output programmability, VMX-synergy™ meets all of the key design criteria.



Safety

VMX-synergy™

Important information

Installers should read and understand the instructions in this guide prior to installing, operating and maintaining the soft start. The following symbols may appear in this guide or on the soft start to warn of potential hazards or to draw attention to certain information.



Dangerous Voltage

Indicates the presence of a hazardous voltage which could result in personal injury or death.

Tension dangereuse

Indique la présence d'une tension dangereuse qui peut entraîner des blessures ou la mort.



Warning/Caution

Indicates a potential hazard. Any instructions that follow this symbol should be obeyed to avoid possible damage to the equipment, and personal injury or death.

Avertissement/Mise en garde

Indique un danger potentiel. Toutes les instructions suivant ce symbole doivent être observées, afin d'éviter les dommages de l'équipement et les blessures ou la mort.



Protective Earth (Ground)

Indicates a terminal which is intended for connection to an external conductor for protection against electric shock in case of a fault.

Mise à la terre (Masse)

Indique une borne dont l'usage prévu est d'être connecter à conducteur externe pour assurer la protection contre les chocs électriques en cas de défauts.

Caution Statements

The examples and diagrams in this manual are included solely for illustrative purposes. The information contained in this manual is subject to change at any time and without prior notice. In no event will responsibility or liability be accepted for direct, indirect or consequential damages resulting from the use or application of this equipment.

Mises en garde

Les exemples et les schémas de ce manuel ne sont donnés qu'à titre illustratif. Les informations présentées dans ce manuel peuvent être modifiées sans avis préalable.

En aucun cas nous n'assumons la responsabilité ou l'obligation pour les dommages directs, indirects ou consécutifs qui résultent de l'utilisation ou application de cet équipement.

Short Circuit

Motortronics soft starts are not short circuit proof. After severe overload or short circuit, the operation of the soft start should be fully tested by an authorised service agent.

Court-circuit

Les démarreurs progressifs Motortronics ne sont pas à l'épreuve des courts-circuits. Après une forte surcharge ou un court-circuit, le fonctionnement du démarreur progressif doit être intégralement vérifié par un agent de maintenance agréé.

Safety (continued)

VMX-synergy™



- VMX-Synergy™ soft starts contain dangerous voltages when connected to the mains supply. Only qualified personnel that have been completely trained and authorised, should carry out installation, operation and maintenance of this equipment.
- Les démarreurs progressifs VMX-Synergy™ contiennent des tensions dangereuses, lorsqu'ils sont connectés à la tension secteur. Les activités d'installation, d'utilisation et d'entretien de cet équipement doivent être effectuées par un personnel qualifié, dûment formé et habilité.
- Installation of the soft start must be made in accordance with existing local and national electrical codes and regulations and have a minimum protection rating.
- Le démarreur progressif doit être installé conformément au code local et nationale d'électricité et à la réglementation en vigueur, et il doit avoir un indice de protection minimal.
- It is the responsibility of the installer to provide suitable grounding and branch circuit protection in accordance with local electrical safety codes.
- Il appartient à l'installateur d'assurer la mise à la terre et la protection du circuit de branchement, conformément au code de sécurité électrique local.
- This soft start contains no serviceable or re-usable parts.
- Ce démarreur progressif ne contient pas de pièces réparables ou réutilisables.
- The STOP function of the soft start does not isolate dangerous voltages from the output of the soft start. An approved electrical isolation device must be used to disconnect the soft start from the incoming supply before accessing electrical connections.
- La fonction STOP du démarreur progressif n'isole pas les tensions dangereuses en sortie du démarreur progressif. Avant d'accéder aux raccordements électriques, il faut utiliser un dispositif d'isolation électrique approuvé pour déconnecter le démarreur progressif de la tension d'entrée.

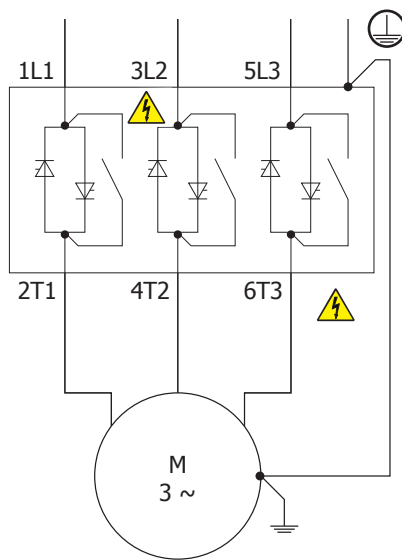

Environment - installation



VMX-synergy™ Size 1, VMX-SGY-101 to VMX-SGY-117.

Dimensions

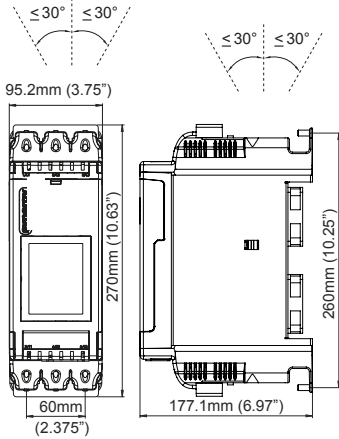

VMX-SGY-101 to VMX-SGY-105 lower fan only
Weight = 3.50 kg (7.71 lbs)

Fitting

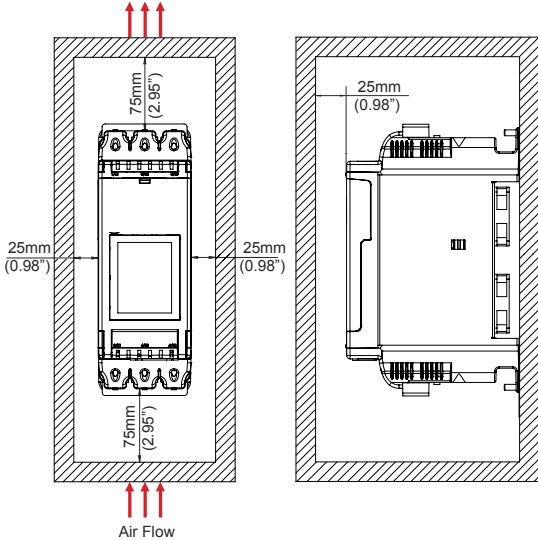

VMX-synergy™ Size 2, VMX-SGY-201 to VMX-SGY-205

Dimensions

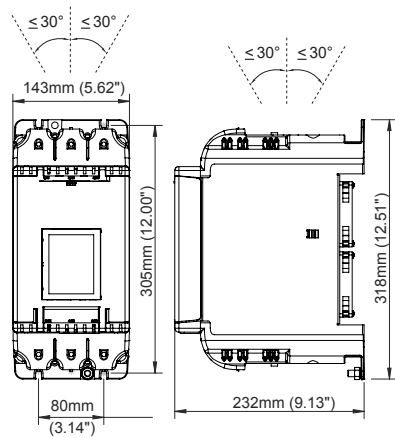

Weight = 6.50 kg (14.33 lbs)

Fitting

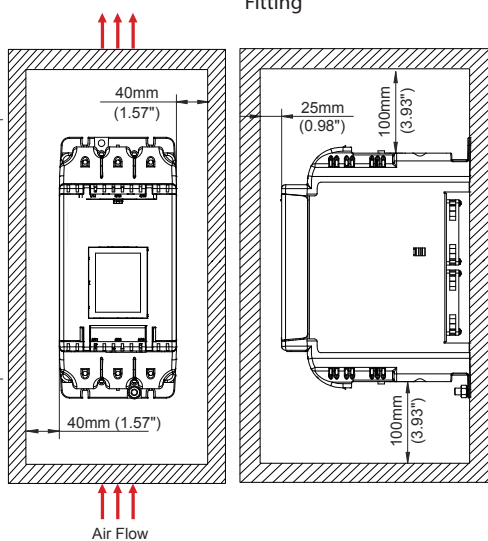

Environment - installation



VMX-synergy™ Size 3, VMX-SGY - 301 to VMX-SGY - 305

Dimensions

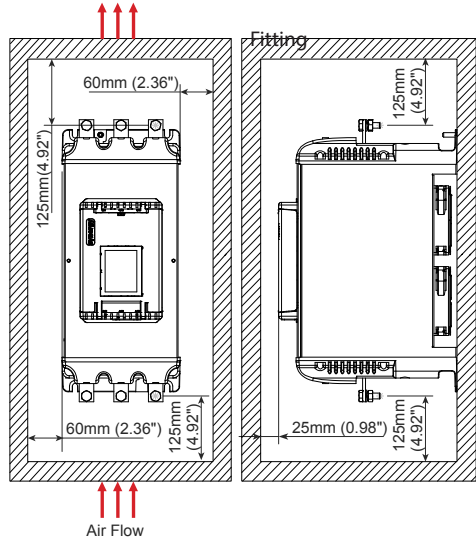
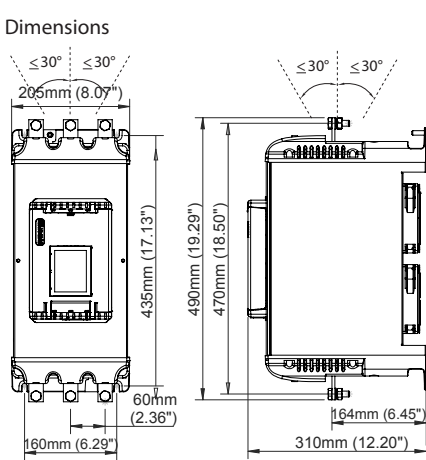

Weight = 16.00 kg (35.27lbs)

VMX-synergy™ Size 3, VMX-SGY - 307 & VMX-SGY - 309

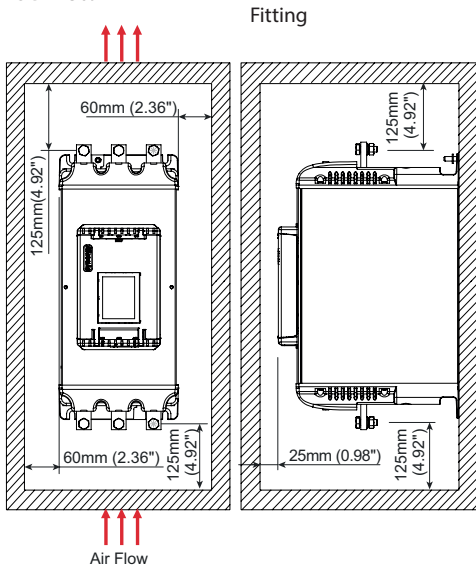
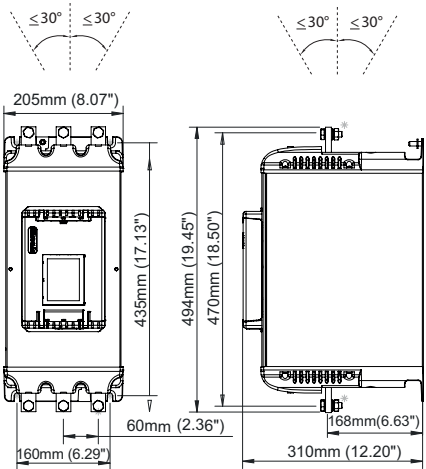

Weight = 21.20 kg (46.73lbs)

Environment - installation

VMX-synergy™



Enclosure Ventilation

When fitting VMX-synergy™ into a cabinet, ventilation must be provided if the heat output of the unit is greater than the cabinet will dissipate. Use the following formula to determine the fan requirement. An allowance has been incorporated into the formula so that the figure for Q is the air delivery in the fan suppliers data.

The maximum power dissipation occurs when energy saving.

Heat dissipated can be approximated with the formula:-

Watts (VMX-synergy™) = 1/2 x VMX-synergy™ current rating x 3

Ventilation intérieure

Lorsque VMX-synergy™ est installé dans une armoire, il faut assurer sa ventilation, si la chaleur produite de l'unité est plus important que la capacité de dissipation de l'armoire. Utiliser la formule suivante pour déterminer la demande de ventilateur. Une tolérance a été incorporé dans la formule, ainsi la figure donnée dans Q est le débit d'air indiqué dans les données du fournisseur du ventilateur.

La puissance maximale de dissipation est atteint en mode économie d'énergie.

La chaleur dissipée peut être estimée par la formule suivante :

Watts (VMX-synergy™) = 1/2 x courant nominal VMX-synergy™ x 3

$$Q = \frac{4 \times Wt}{(T_{\max} - T_{\text{amb}})}$$

Q = volume of air (cubic metres per hour-m³/h)

Wt = Heat produced by the unit and all other heat sources within the enclosure (Watts)

Tmax = Maximum permissible temperature within the enclosure

(50°C for a fully rated VMX-synergy™)

Tamb = Temperature of the air entering the enclosure (°C)

If you prefer to work in CFM, substitute °F for °C. Q is now in CFM

Q = quantité d'air (mètre cube par heure - m³/h)

Wt = Chaleur produite par l'unité et toutes autres sources de chaleur dans l'armoire (Watts)

Tmax = Température maximale admissible dans l'armoire (50°C pour VMX-synergy™ en

puissance maximale)

Tamb = Température de l'air entrant dans l'armoire (°C)

Pour calculer en CFM, remplacer °C par °F. Ainsi Q est en CFM.

Wiring connection



Required rating	Default	Programmable	Description	Default	Programmable	Required rating
#1			group 1 input common			
#1	start/stop	yes	relay N/C	fault	yes	230Vac 1A AC15, 30Vdc 0.5A Resistive
#1		yes	relay N/O	fault	yes	230Vac 1A AC15, 30Vdc 0.5A Resistive
			group 2 input common			
	reset	yes	relay N/O	running	yes	230Vac 1A AC15, 30Vdc 0.5A Resistive
			relay N/O	end of start	yes	230Vac 1A AC15, 30Vdc 0.5A Resistive
			analog output	0-10V	yes	0 to 10V 10mA / 4-20mA
			analog 0V	0V		0V
			analog input	0-10V	Yes	0 to 10V 10mA / 4-20mA
#3	SEE TABLE 1, U _s		control supply			SEE TABLE 1, U _s
#3	SEE TABLE 1, U _s		control supply			SEE TABLE 1, U _s

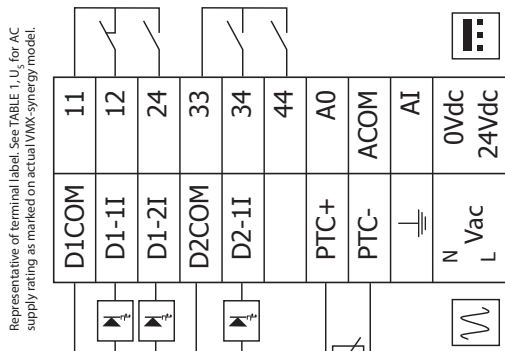

*24Vdc Specification
Residual ripple 100mV
24Vdc 60W
Spikes/switching Peaks 240mV
Turn On/Off response
No overshoot of V out
Overvoltage protection output voltage must be clamped to $-30Vdc$

Required rating	Default	Programmable	Description
#1			Group 1 input common
#1	start/stop	yes	opto-coupled input
#1	None	yes	opto-coupled input
			group 2 input common
	reset	yes	opto-coupled input
			not used
	OFF		thermistor
	OFF		thermistor
			signal ground
#3	SEE TABLE 1, U _s		control supply
#3	SEE TABLE 1, U _s		control supply

VMX-SG1-101 to VMX-SG1-305 Control Power Consumption 60W
VMX-SG1-307 to VMX-SG1-309 Control Power Consumption 120W
Table 1: Interface Control Voltages, 2 Amp supply (continuous).

Model No (6):	U _c (+10% -15%)	U _s (+10% -15%)	Notes
VMX-SG1-101-4-01 to VMX-SG1-305-4-01	110Vac or 230Vac or 24Vdc	110 - 230Vac or 24Vdc	The system can have either a 110/230Vac mains or 24Vdc input. NOT both. Le système peut avoir soit une alimentation principale de 110/230 Vac ou de 24 Vdc, mais en aucun cas les deux simultanément.
VMX-SG1-307-4-02 / VMX-SG1-309-4-02	110Vac	110Vac	#4
VMX-SG1-307-4-03 / VMX-SG1-309-4-03	230Vac	230Vac	#4

Notes	
#1	The programmed digital input setting on D1COM, D1-1I, D1-2I must correspond to the voltage applied to these terminals to avoid risk of damage to the equipment. Afin d'éviter d'endommager l'équipement, le réglage de l'entrée numérique programmée sur D1COM, D1-1I, D1-2I doit correspondre à la tension appliquée à ces bornes.
#2	The programmed digital input setting on D2COM, D2-1I must correspond to the voltage applied to these terminals to avoid risk of damage to the equipment. Afin d'éviter d'endommager l'équipement, le réglage de l'entrée numérique programmée sur D2COM, D2-1I doit correspondre à la tension appliquée à ces bornes.
#3	The control supply can be 110 to 230Vac applied to the N, L terminals or 24Vdc applied to the 0Vdc, 24V input terminals. The correct voltage as specified must only be applied to one of these supply inputs to avoid risk of damage to the equipment. L'alimentation contrôle peut être 110 à 230 Vca appliquée aux bornes N et L, ou 24 Vcc, appliquée aux bornes 0Vdc, 24 V. Afin d'éviter d'endommager l'équipement, la tension appropriée selon les indications ne doit être appliquée qu'à une entrée d'alimentation.
#4	Refer to VMX-Synergy User Manual MAN-SG1-031 for factory default settings.

Wiring connection

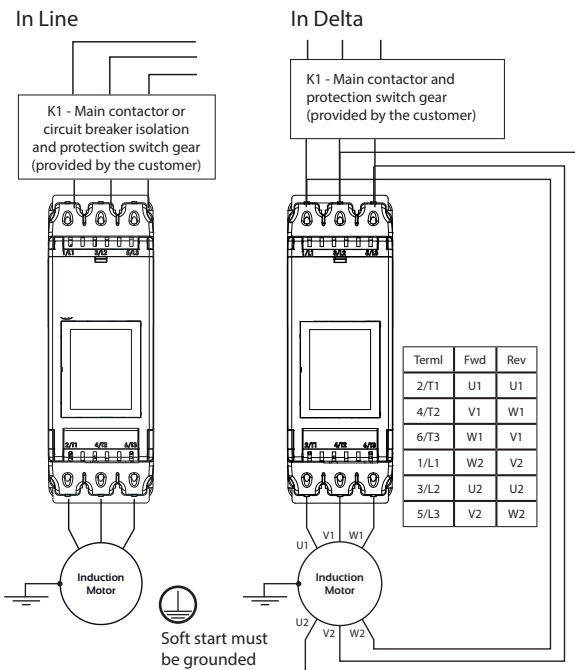

Note: Circuit breaker isolation alone is not allowed for In Delta operation. K1 (Main contactor) controlled by the Running relay MUST be used for isolation.

! For suitable short circuit protection devices (SCPD's) see short Circuit Protection in the Technical Information/ standards section of this guide.

Pour un dispositif de protection approprié contre le court-circuit, voir la protection contre le court-circuit dans la section « Informations techniques/normes » du présent guide.

! For wire size and torque requirements see Technical Information/ standards section of this guide.

Pour les dimensions de câble et les besoins en couple, voir la section « Informations techniques/normes » du présent guide.

! In Delta For this configuration applying the equation. $VMX-synergy^{TM} I_e = I_e (motor) / \sqrt{3}$

Allows lower current rating VMX-synergyTM than the motor.

When In Delta configuration is used a line contactor controlled by VMX-synergyTM MUST be used with the In Delta Firing Mode selected in the advanced menu.

! En Delta Pour cette configuration, appliquer l'équation. suivante : $VMX-synergy^{TM} I_e = I_e (moteur) / \sqrt{3}$

Cela permet le courant nominal inférieur de VMX-synergyTM par rapport au moteur.

Lorsque En Delta configuration est utilisée, IL FAUT utiliser un sectionneur principal contrôlé par VMX-synergyTM. En Delta mode de fonctionnement, sélectionné dans le menu avancé.

Wiring connection



3 Wire Control Diagram
110/230Vac control supply (U_s)
and digital input (U_c) programming.

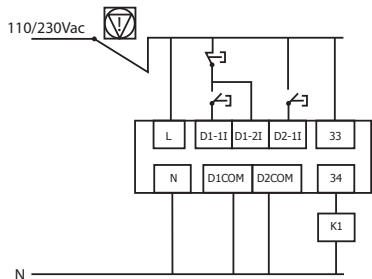

3 wire Control Diagram 24Vdc control supply (U_s)
and digital input (U_c) programming (only
applicable for VMX-SGY-101 to VMX-SGY-305).

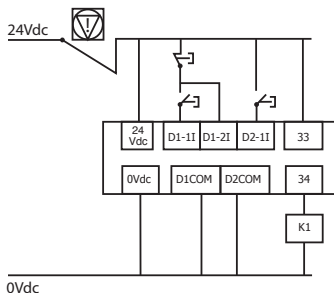

Digital
input
programming

D1 - 1I = Start
D1 - 2I = Stop
D2 - 1I = Reset

	CAUTION
#1	<p>REFER TO TABLE 1 on page 8 for input control voltages. These recommended wiring diagrams are specifically where the control supply voltage (U_s) is identical to the control circuit voltage (U_c) and not to be supplied separately. Other wiring configurations must also be in accordance with existing local and national codes and regulations.</p> <p>RÉFÉRER au TABLEU 1 à la page 8 pour des tensions de contrôle d'entrée.</p> <p>Ces schémas de câblage sont recommandées spécifiquement lorsque la tension d'alimentation de commande (U_s) est identique à la tension du circuit de commande (U_c). U_s et U_c ne doivent pas être alimentés séparément. Toutes les configurations de câblage doivent également être en conformité avec les codes et les règlements locaux et nationaux en vigueur.</p>
#2	<p>Power factor correction capacitors must NOT be positioned between the soft start and the motor or there is a risk of damaging thyristors due to current peaks.</p> <p>Condensateurs de correction de facteur de puissance NE doivent pas être placés entre le moteur et le démarreur progressif ou il y a un risqué d'endommager les thyristors en raison des pics de courants.</p>

110/230Vac (U_s) and (U_c) user programmable control diagram

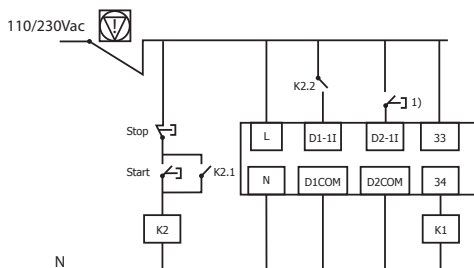

24Vdc (U_s) and (U_c) user programmable control diagram (only applicable for VMX-SGY-101 to VMX-SGY-305)

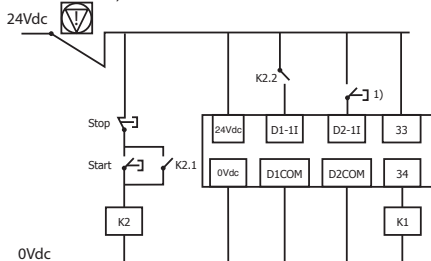

User programmable Inputs are fully programmable

D1 - 1I = High Start / Low Stop
D1 - 2I = None
D2 - 1I = High Reset

1) Optional high reset. If this reset is required ensure "User Programmable" is selected in the control method menu found in the Digital Inputs menu. If you would prefer the reset to work by removing and reapplying the Start Signal on D1 - 1I then select "Two wire control" in the control method menu.

Soft start motor reversing circuit **VMX-synergy™**

Below is a soft start reversing circuit without soft stop, it shows the main components required. You must follow your local wiring and electrical regulations when constructing this circuit, set to 'User Programmable' control.

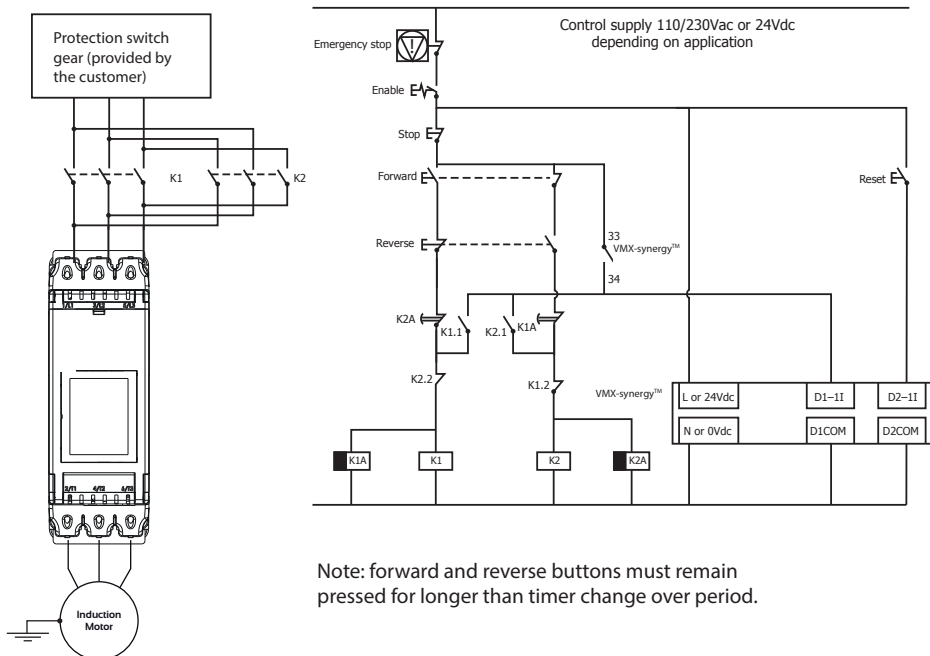

Note: forward and reverse buttons must remain pressed for longer than timer change over period.

CAUTION

REFER to TABLE 1 on page 8 for input control voltages.
 RÉFÉRER au TABLEU 1 à la page 8 pour des tensions de contrôle d'entrée.

Item	Description
K1, K2	AC3 rated forward/reverse contactors
K1A, K2A	1 second drop out delay timers
VMX-synergy™	VMX-synergy™ soft start

These are the major components of the system. Local wiring regulations should be observed. Note the use of timers to ensure that a reversed voltage is not applied to the starter/motor before the motor field has had some chance to die away.

The thermal capabilities of VMX-synergy™ should be considered.

Sequential Soft Start diagram

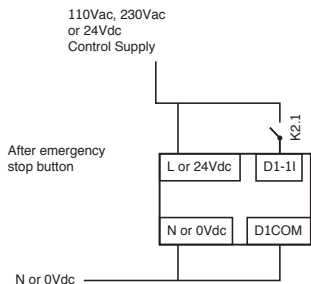

CAUTION

REFER to TABLE 1 on page 8 for input control voltages.
 RÉFÉRER au TABLEU 1 à la page 8 pour des tensions de contrôle d'entrée.

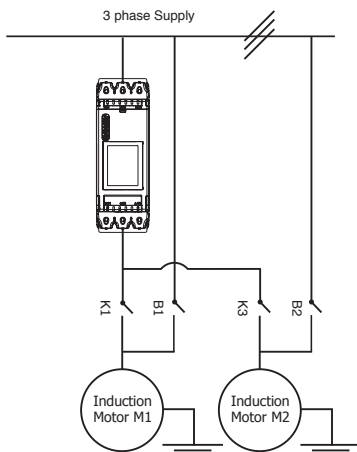

110Vac, 230Vac or 24Vdc Control Supply

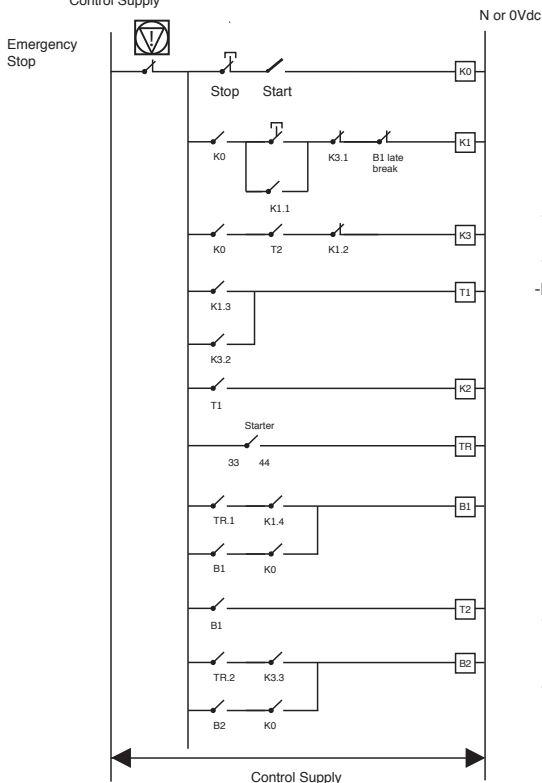

Notes

Soft Starter must have stop time set to 0

T1 Time between K1 or K3 closing and the starter being energised - 0.5 sec minimum.

T2 Time between B1 closing and K3 closing - Dependant on application - 0.5 sec minimum.

Set to 'Two wire control'

Emergency stop switch cuts off control supply and drops out starter and motors. Stop switch drops control supply from contactors and timers stopping both motors. Start switch initiates softstart then bypass of motor 1 immediately followed by softstart then bypass of motor 2.



Soft Starter must be rated for combined starting duty.

The control logic can be continued for more motors.

The thermal capabilities of VMX-synergy™ should be considered.

Programming

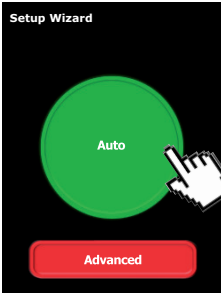
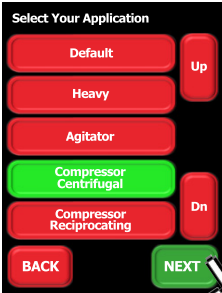
VMX-synergy™

1. **Setup Wizard**

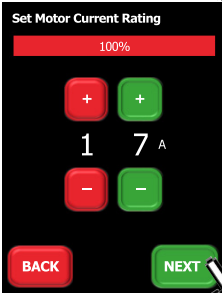
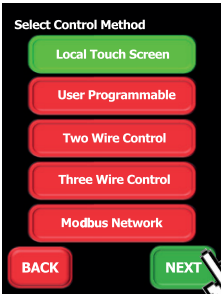
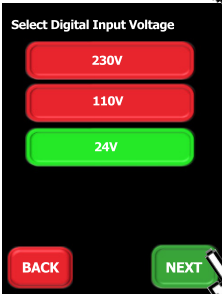
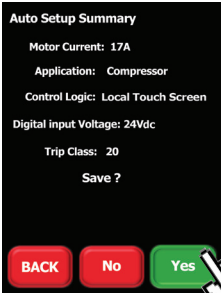
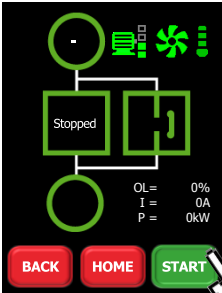
2. **Select Your Application**

3. **Select Your Application**

Please note:
Only appears if application with a trip class higher than 10 is selected
4. **Set Motor Current Rating**

5. **Select Control Method**

6. **Select Digital Input Voltage**

7. **Auto Setup Summary**

8. **Control Panel**

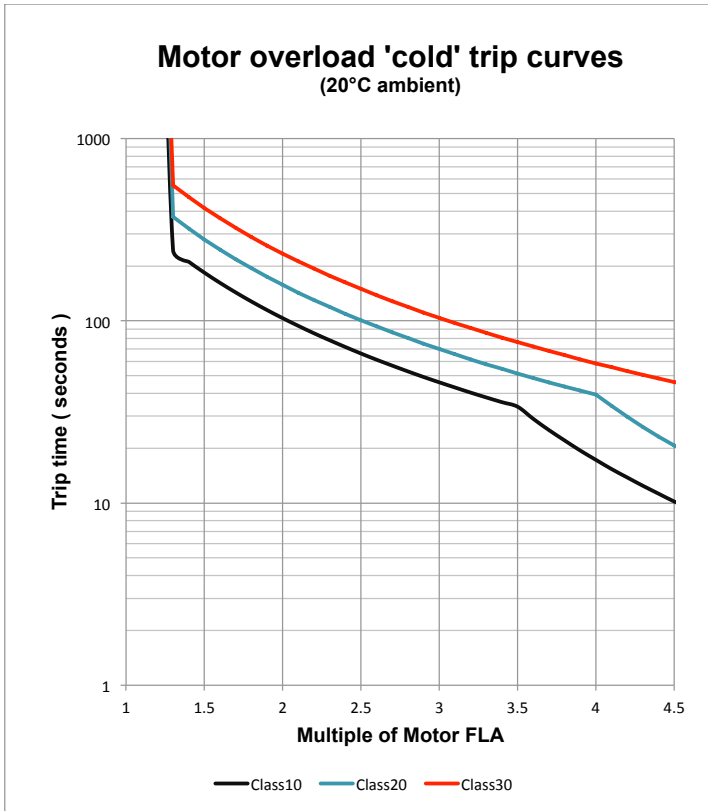
Rating table

VMX-synergy™

Type	IEC, I _e A ³⁾	kW ¹⁾		UL, FLA A ⁴⁾	HP ²⁾				Control supply U _s
		230V	400V		200V	208V	220- 240V	440- 480V	
VMX-SGY-101-4-01	17	4	7.5	17	3	5	5	10	24Vdc or 110Vac to 230Vac
VMX-SGY-103-4-01	22	5.5	11	21	5	5	5	15	
VMX-SGY-105-4-01	29	7.5	15	27	7.5	7.5	7.5	20	
VMX-SGY-107-4-01	35	7.5	18.5	34	10	10	10	25	
VMX-SGY-109-4-01	41	11	22	40	10	10	10	30	
VMX-SGY-111-4-01	55	15	30	52	15	15	15	40	
VMX-SGY-113-4-01	66	18.5	37	65	20	20	20	50	
VMX-SGY-115-4-01	80	22	45	77	20	25	25	60	
VMX-SGY-117-4-01	100	30	55	96	30	30	30	75	
VMX-SGY-201-4-01	132	37	75	124	40	40	40	100	
VMX-SGY-203-4-01	160	45	90	156	50	50	60	125	
VMX-SGY-205-4-01	195	55	110	180	60	60	60	150	
VMX-SGY-301-4-01	242	75	132	242	75	75	75	200	
VMX-SGY-303-4-01	302	90	160	302	100	100	100	250	
VMX-SGY-305-4-01	361	110	200	361	125	125	150	300	
VMX-SGY-307-4-02	430	132	250	414	150	150	150	350	110Vac
VMX-SGY-309-4-02	500	150	280	477	150	150	150	400	
VMX-SGY-307-4-03	430	132	250	414	150	150	150	350	230Vac
VMX-SGY-309-4-03	500	150	280	477	150	150	150	400	

- 1) Rated operational powers in kW according to IEC 60072-1 (primary series) corresponding to IEC current rating.
- 2) Rated operational powers in HP according to UL508 corresponding to FLA current rating.
- 3) The IEC, I_e rating will apply for EN 60947-4-2 max rating index 195A: AC-53a: 3.5-17: 90-5 and 500A: AC-53a: 3.5-17: 90-3.
- 4) The UL, FLA rating applies for a maximum surrounding air temperature of 50°C.



* Please note: When the overload has tripped there is a forced cooling time to allow the overload to recover before the next start.

Technical information/Standards **VMX-synergy**TM

Rated operational voltages	U_e	200Vac to 480Vac	
Rated operational current	I_e	See Rating table	
Rating index		VMX-SGY-101 to VMX-SGY-205	Ie: AC-53a: 3.5-17: 90-5
		VMX-SGY-301 to VMX-SGY-309	Ie: AC-53a: 3.5-17: 90-3
Rated frequency		50 to 60Hz	
Rated duty		Uninterrupted	
Form designation		Form 1 Internally bypassed	
Rated insulation voltage	U_i	480V	
Rated impulse withstand voltage	U_{imp}	Main circuit	4kV
		Control supply circuit	2.5kV
IP code		Main circuit	IP00 (IP 20 optional)
		Supply and control circuit	IP 20
Pollution degree		2	
Rated conditional short-circuit current and type of co-ordination with associated short circuit protective device (SCPD).		Type 1 co-ordination. See short circuit protection table for rated conditional short-circuit current and required current rating and characteristics of the associated SCPD	
Rated control circuit voltage (programmable)	U_c	24Vdc, 110Vac or 230Vac	Protect with 4A UL Listed fuse
Rated control supply voltage	U_s	See Rating table, 2 Amp supply (continuous).	
Relay specification		AC-15 230Vac, 1A DC-13 30Vdc, 0.7A	
EMC Emission levels	EN 55011	Class A 1	
EMC Immunity levels	IEC 61000-4-2	8kV/air discharge or 4kV/contact discharge	
	IEC 61000-4-3	10 V/m	
	IEC 61000-4-4	2kV/5kHz (main power and ports)	
		1kV/5kHz (signal ports)	
	IEC 61000-4-5	2kV line-to-ground 1kV line-to-line	
IEC 61000-4-6	10V		
Humidity		Max. 85% non-condensing, not exceeding 50% at 40°C	
<p>NOTICE: This product has been designed for environment A. Use of this product in environment 1 B may cause unwanted electromagnetic disturbances, in which case the user may be required to take adequate mitigation measures.</p>			

Standards



-20°C (-4°F) to 50°C (122°F). Above 50°C de-rate linearly by 4% of VMX-synergy™ Ie per °C to a maximum of 60°C (140°F).



Altitude above sea level 1000m (3281ft). Above 1000m de-rate by 1% of VMX-synergy™ Ie per 100m (328ft) to a maximum altitude of 2000m (6562ft).

Please note for higher temperatures and altitudes contact your supplier.

VMX-synergy™ models bearing the ETL listing mark are ETL UL508 and CSA C22.2 No.14 listed to US and Canadian safety standards respectively.

Short circuit protection

#1 Suitable for use in a circuit delivering not more than $I_{q,rms}$ Symmetrical Amperes, 480 Volts maximum, when protected by Class J time delay fuses with a maximum rating of Z_1 or by a circuit breaker with a maximum rating of Z_2 as in table below.

#2 Correctly selected semiconductor fuses can provide additional protection against damage to the VMX-synergy™ unit (this is sometimes referred to as type 2 co-ordination). These semiconductor fuses are recommended to provide this increased protection

Type designation (VMX-SGY-***)			101	103	105	107	109	111	113	115	117
Rated operational	I_e	A	17	22	29	35	41	55	66	80	100
Rated conditional short circuit current	I_q	kA	5	5	5	5	5	5	5	10	10
Class J time-delay fuse #1	Maximum rating Z_1	A	30	40	50	60	70	100	125	150	175
UL Listed inverse-time delay-circuit breaker #1	Maximum rating Z_2	A	60	60	60	60	60	150	150	250	300
Semiconductor fuse (class aR) #2	Type	Mersen 6,9 URD 30_ Bussmann 170M30_ Bussmann 170M31_ Bussmann 170M32_ SIBA 20 61_									
	Fuse Rating	A	100	100	160	160	160	200	200	250	315

Standards

Short Circuit protection (continued).

Type designation (VMX-SGY-***)			201	203	205	301	303	305	307	309
Rated operational currents	I_e	A	132	160	195	242	302	361	430	500
Rated conditional short circuit current	I_a	kA	10	10	10	18	18	18	18	18
Class J time-delay fuse #1	Maximum rating Z_1	A	225	300	350	450	500	500	600	600
UL Listed inverse-time delay-circuit breaker #1	Maximum rating Z_2	A	350	450	500	700	800	1000	1000	1000
Semiconductor fuse (class aR) #2	Type	A	Mersen 6,9 URD 31____ Bussmann 170M40____ Bussmann 170M41____ Bussmann 170M42____ SIBA 20 61____				Mersen 6,9 URD 33____ Bussmann 170M60____ Bussmann 170M61____ Bussmann 170M62____ SIBA 20 63____			
	Fuse rating	A	400	550	550	700	800	900	1000	1100

Wire sizes and torques

Terminal		Models	Wire Size		Torque	
			mm ²	AWG	Nm	lb-in
Main Terminals Cu STR 75°C only	Terminal	VMX-SGY-101 to VMX-SGY-117	2.5 – 70	12 – 2/0	9	80
		VMX-SGY-201 to VMX-SGY-205	4 - 185	12-350MCM		
	M10 bolt	VMX-SGY-301 to VMX-SGY-305	2 x 95	2 x 2/0	14	123
		VMX-SGY-307 to VMX-SGY-309	2 x 150	2 x 350MCM		
Control terminals		All models	0.2-1.5	24-16	0.5	4.5
 Protective Earth ¹⁾ Cu Only Single conductor	M6 stud	VMX-SGY-101	≥ 4	≥ 12	8	70
		VMX-SGY-103 to VMX-SGY-111	≥ 6	≥ 10		
		VMX-SGY-113 to VMX-SGY-117	≥ 10	≥ 8		
	M8 stud	VMX-SGY-201 to VMX-SGY-205	≥ 16	≥ 6	12	105
		VMX-SGY-301	≥ 25	≥ 4		
		VMX-SGY-303 to VMX-SGY-305	≥ 35	≥ 3		
		VMX-SGY-307 to VMX-SGY-309	≥ 35	≥ 2		

1) Protective Earth wire size based on bonding conductor requirements of UL508 and UL508A and CSA C22. No.14

VMX-synergy™

Quick Start Guide

(E) Electric current! Danger to life!

Only skilled or instructed persons may carry out the operations.

(D) Lebensgefahr durch Strom!

Nur Elektrofachkräfte und elektrotechnisch unterwiesene Personen dürfen die im Folgenden beschriebenen Arbeiten ausführen.

(F) Tension électrique dangereuse!

Seules les personnes qualifiées et averties doivent exécuter les travaux ci-après.

(E) Corriente eléctrica! Peligro de muerte!

El trabajo a continuación descrito debe ser realizado por personas cualificadas y advertidas.

(I) Tensione elettrica: Pericolo di mortal!

Solo persone abilitate e qualificate possono eseguire le operazioni di seguito riportate.

(中) 触电危险!

只允许专业人员和受过专业培训的人员进行下列工作。

(R) Электрический ток! Опасно для жизни!

Только специалисты или проинструктированные лица могут выполнять следующие операции.

(N) Levensgevaar door elektrische stroom!

Uitsluitelijk deskundigen in elektriciteit en elektrotechnisch geïnstrueerde personen is het toegestaan, de navolgend beschrevene werkzaamheden uit te voeren.

(B) Livsfare på grund af elektrisk strøm!

Kun uddannede el-installatører og personer der er instruerede i elektrotekniske arbejdsopgaver, må udføre de nedenfor anførte arbejder.

(G) Προσοχή, κίνδυνος ηλεκτροπληξίας!

Οι εργασίες που αναφέρονται στην συνέχεια θα πρέπει να εκτελούνται μόνο από ηλεκτρολόγους και ηλεκτροτεχνίτες.

(P) Perigo de vida devido a corrente eléctrica!

Apenas electricistas e pessoas com formação electrotécnica podem executar os trabalhos que a seguir se descrevem.

(S) Livsfara genom elektrisk ström!

Endast utbildade elektriker och personer som undervisats i elektroteknik får utföra de arbeten som beskrivs nedan.

(I) Hengenvaarallinen jännitel!

Vain pätevät sähköasentajat ja opastusta saaneet henkilöt saavat suorittaa seuraavat työt.

(S) Nebezpečí úrazu elektrickým proudem!

Níže uvedené práce směji provádět pouze osoby s elektrotechnickým vzděláním.

(E) Eluhohtlik! Elektrilöögihoht!

Järgnevalt kirjeldatud töid tohib teostada ainult elektriala spetsialistid või elektrotehnilise instrueerimise läbinud personal.

(H) Életveszély az elektromos áram révén!

Csak elektromos szakemberek és elektrotechnikában képzett személyek végezhetik el a következőkben leírt munkákat.

(V) Elektriská stráva apraudu dzīvību!

Tālāk aprakstītos darbus drīkst veikt tikai elektrospeciālisti un darbam ar elektrotehniskām iekārtām instruetās personas!

(L) Pavojus gvybei dėl elektros srovės!

Tik elektrikai ir elektrotechnikos specialistai gali atlikti žemiau aprašytus darbus.

(P) Poráženie prądem elektrycznym stanowi zagrożenie dla życia!

Opisane poniżej prace mogą przeprowadzać tylko wykwalifikowani elektrycy oraz osoby odpowiednio poinstruowane w zakresie elektrotechniki.

(S) Življenjska nevarnost zaradi električnega toka!

Spodaj opisana dela smejo izvajati samo elektrostrokovnjaki in elektrotehnično poučene osebe.

(SK) Nebezpečnostv ohrozenia života elektrickým prúdom!

Práce, ktoré sú nižšie opísané, smú vykonávať iba elektroodborníci a osoby s elektrotechnickým vzdelaním.

(B) Опасност за живота от електрически ток!

Операциите, описани в следващите раздели, могат да се извършват само от специалисти-електротехници и инструктиран електротехнически персонал.

(T) Atentjeli Pericol electric!

Toate lucrările descrise trebuie efectuate numai de personal de specialitate calificat și de persoane cu cunoștințe profunde în electrotehnică.

California Customers: California Proposition 65 Warning

WARNING: this product and associated accessories may contain chemicals known to the State of California to cause cancer, birth defects, or other reproductive harm.

For more information visit <https://p65warnings.ca.gov>





SCATTERGOOD & JOHNSON LTD

ELECTRICAL ENGINEERING & FLUID CONTROL DISTRIBUTORS

Est.1899

At Scattergood & Johnson Ltd, we pride ourselves on being a technical distributor to specialist industries.

Working with a range of quality product suppliers across a number of specialist markets, we are not your average 'box shifter' - we are your technical and supply chain partner.

We fully support every product we sell - for free! Our internal team and external sales engineers can answer any product or application question, no matter the complexity.

Backing up this technical ability is a range of 50,000+ products available from stock for nationwide next day delivery (same day if required!), or you can collect what you need from any of our trade counters around the UK.

Select your specialist interest below to learn more about how we can help.



Online, In Branch and On the Road - Scattergood & Johnson Ltd, there when you need us.

www.scatts.co.uk