

VMX-synergy™ **MOTORTRONICS** *Solid State AC Motor Control*

Quick Start Guide

VMX-SGY-401 to VMX-SGY-505



Redefining Motor Control

VMX-synergy™

The original pioneers of soft start technology, Motortronics have been at the forefront of motor control innovation since the 1970's. Motortronics have manufactured and supplied over 1 million products into the market place and are recognised as the reference point for many control solution providers worldwide. In 2009, the need for a new technology that bridged the gap between drive technology and soft start was recognised and the development process began for VMX-synergy™, a new form of motor control that met the needs of those requiring the functionality of a drive in a fixed speed application. The key aspects of a drive (energy saving and communications) as well as original features of a soft start including internal bypass and lower cost, meant the base design was enhanced even further.

iERS (Intelligent Energy Recovery System) is Motortronics patented energy saving system with a combined internal bypass to save energy on lightly loaded motors. iERS reduces the voltage and current supplied to lightly loaded motors to only allow the motor to consume the exact amount of energy required to maintain the speed at that load. When the motor is at full load the internal bypass closes, this reduces the losses produced by the control element. This combined approach enables iERS to save more energy in more applications than any other competing technology.

iERS has been market proven over the past 10 years and has now reached its latest development realising even greater savings. Applications such as compressors, refrigerators, pump jacks, moulding machines and chillers can typically see savings of around 8-40% of total energy consumption when lightly loaded.

With size and cabinet capacity an ever increasing focus, Motortronics developed the world's smallest power to size ratio motor controller. VMX-synergy™ utilised Motortronics globally renowned Automatic Setup feature to programme the unit to each individual application using only a 8 button process. Since then it has removed buttons and uses touch screen technology bringing the user interface to even greater management levels.

With full motor overload protection as well as full data logging, upgradeable software in the field and extensive input/output programmability, VMX-synergy™ meets all of the key design criteria.

Enabling the Intelligent Energy Recovery System (iERS)

iERS can produce energy savings in suitable applications. However, the user should have an understanding of the application and load characteristic before enabling the feature.

Loads which exhibit frequent changes in motor torque may cause the VMX-synergy™ unit to switch rapidly between the iERS on state and the 'bypassed' state as the motor torque changes. If left unchecked, such switching may cause premature wear of the internal bypass components and may invalidate the warranty.

If the loaded / unloaded state changes more than 4 times per minute, iERS should not be enabled.

Applications that are typically well suited to the iERS feature include; Artificial Lift Pump Jacks, Injection Moulding Machines, Mixers, Saws, Rolling Mills, Grinders, Hydraulic Pumps, Crushers, Conveyors, Compressors and Vertical Transport applications.

If the user requires further support regarding the suitability of the application, they should seek support from Motortronics or an Authorised Distributor before enabling the iERS function



Safety

Important information

Installers should read and understand the instructions in this guide prior to installing, operating and maintaining the soft start. The following symbols may appear in this guide or on the soft start to warn of potential hazards or to draw attention to certain information.



Dangerous Voltage

Indicates the presence of a hazardous voltage which could result in personal injury or death.



Warning/Caution

Indicates a potential hazard. Any instructions that follow this symbol should be obeyed to avoid possible damage to the equipment, and personal injury or death.



Protective Earth (Ground)

Indicates a terminal which is intended for connection to an external conductor for protection against electric shock in case of a fault.

Caution Statements

The examples and diagrams in this manual are included solely for illustrative purposes. The information contained in this manual is subject to change at any time and without prior notice.

In no event will responsibility or liability be accepted for direct, indirect or consequential damages resulting from the use or application of this equipment.

Short Circuit

Motortronics soft starts are not short circuit proof. After severe overload or short circuit, the operation of the soft start should be fully tested by an authorised service agent.



- VMX-Synergy™ soft starts contain dangerous voltages when connected to the mains supply. Only qualified personnel that have been completely trained and authorised, should carry out installation, operation and maintenance of this equipment.

- Installation of the soft start must be made in accordance with existing local and national electrical codes and regulations and have a minimum protection rating.

- It is the responsibility of the installer to provide suitable grounding and branch circuit protection in accordance with local electrical safety codes.

- The STOP function of the soft start does not isolate dangerous voltages from the output of the soft start. An approved electrical isolation device must be used to disconnect the soft start from the incoming supply before accessing electrical connections.

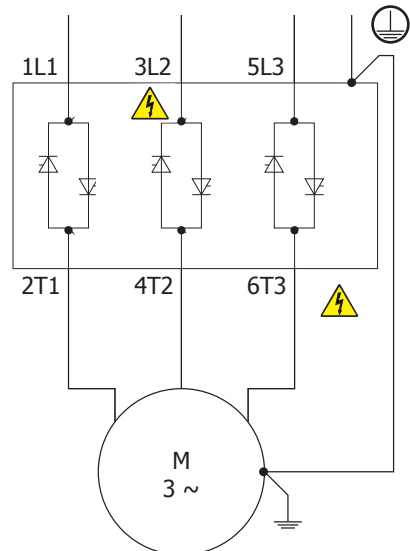

Environment - installation

VMX-synergy™

VMX-synergy™ VMX-SGY-401 to VMX-SGY-403

Weight = 65.00 kg (143.3lbs)

Dimensions

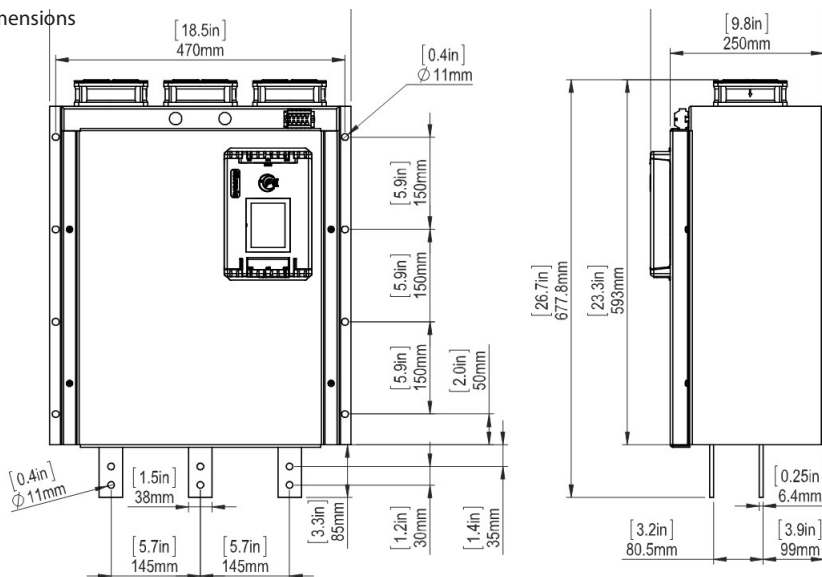

VMX-synergy™ VMX-SGY-501 to VMX-SGY-505

Weight = 72.0 kg (158.7lbs)

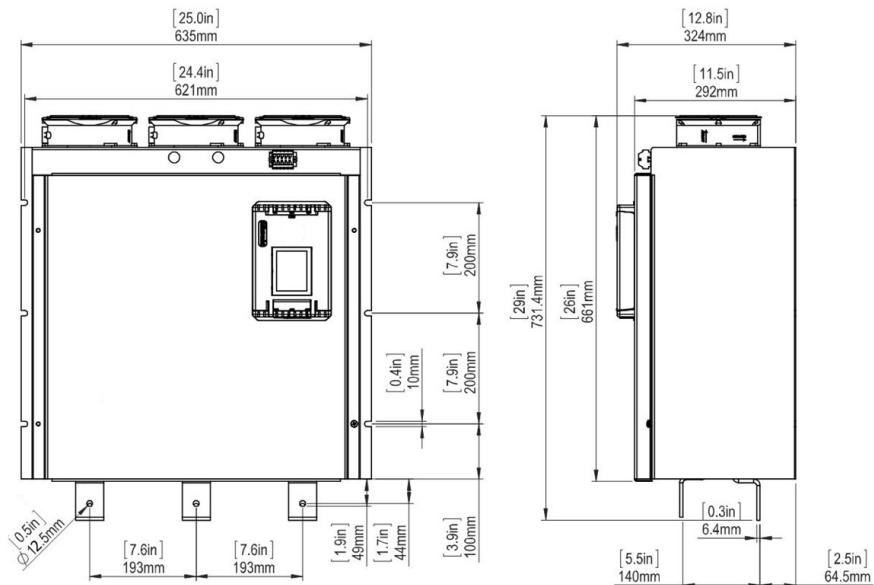

Environment - installation



Enclosure Ventilation

When fitting VMX-synergy™ into a cabinet, ventilation must be provided if the heat output of the unit is greater than the cabinet will dissipate. Use the following formula to determine the fan requirement. An allowance has been incorporated into the formula so that the figure for Q is the air delivery in the fan suppliers data.

Without external bypass, the maximum power dissipation occurs when energy saving.

Heat dissipated can be approximated with the formula:-
Watts (VMX-synergy™) = VMX-synergy™ current rating x 3

With external bypass installed, the formula becomes:-

Watts (VMX-synergy™) = 1/2 x VMX-synergy™ current rating x 3

$$Q = \frac{4 \times Wt}{(T_{\max} - T_{\text{amb}})}$$

Q = volume of air (cubic metres per hour-m³/h)

Wt = Heat produced by the unit and all other heat sources within the enclosure (Watts)

Tmax = Maximum permissible temperature within the enclosure
(40°C for a fully rated VMX-synergy™)

Tamb = Temperature of the air entering the enclosure (°C)

If you prefer to work in CFM, substitute °F for °C. Q is now in CFM

Wiring connection



Required rating	Programmable	Default	Description	Required rating
#1			group 1 relay common	
#1	yes	fault	relay N/C	230Vac 1A AC15, 30Vdc 0.5A Resistive
#1	yes	fault	relay N/O	230Vac 1A AC15, 30Vdc 0.5A Resistive
			group 2 relay common	
	yes	running	relay N/O	230Vac 1A AC15, 30Vdc 0.5A Resistive
	yes	end of start	relay N/O	230Vac 1A AC15, 30Vdc 0.5A Resistive
	yes	0-10V	analog output	0 to 10V 10mA / 4-20mA
			analog 0V	0V
	Yes	0-10V	analog input	0 to 10V 10mA / 4-20mA
#3			control supply	SEE TABLE 1, U ₃
#3			control supply	SEE TABLE 1, U ₃

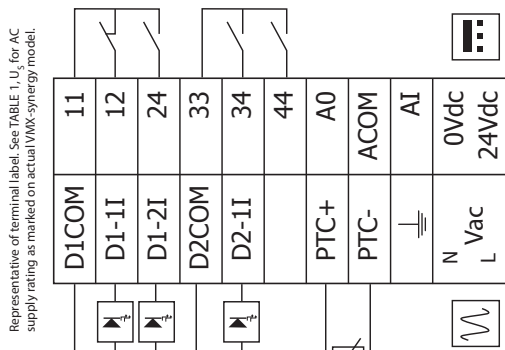

Required rating	Programmable	Default	Description
#1			Group 1 input common
#1	yes	start/stop	opto-coupled input
#1	yes	None	opto-coupled input
			group 2 input common
	yes	reset	opto-coupled input
			not used
		OFF	thermistor
		OFF	thermistor
			signal ground
#3	SEE TABLE 1, U ₃		control supply
#3	SEE TABLE 1, U ₃		control supply

*24Vdc Specification
 24Vdc 60W
 Residual ripple 100mV
 Spikes/switching Peaks 240mV
 Turn On/Off response
 No overshoot of V out
 Overvoltage protection output voltage must be clamped to $-30Vdc$

Model No. (s)	U ₃ (+10% -15%)	U ₄ (+10% -15%)	Notes
VMX-SGY-401 to VMX-SGY-505 Control Power Consumption Table 1I- Interface Control Voltages, 2 Amp supply (continuous).	U ₃ (+10% -15%)	U ₄ (+10% -15%)	
VMX-SGY-401-4-01 to VMX-SGY-505-4-01	110V/5s or 230V/5s or 24Vdc	110V/5s or 230V/5s or 24Vdc #4	The system can have either a 110/230V ac mains or 24Vdc input NOT both.

Notes
#1 The programmed digital input setting on D1COM, D1-1I, D1-2I must correspond to the voltage applied to these terminals to avoid risk of damage to the equipment.
#2 The programmed digital input setting on D2COM, D2-1I must correspond to the voltage applied to these terminals to avoid risk of damage to the equipment.
#3 The control supply can be 110 to 230Vac applied to the N, L terminals or 24Vdc applied to the 0Vdc, 24V input terminals. The correct voltage as specified must only be applied to one of these supply inputs to avoid risk of damage to the equipment.
#4 Refer to VMX-synergy User Manual (MAN-SGY-031 for factory default settings.

Wiring connection

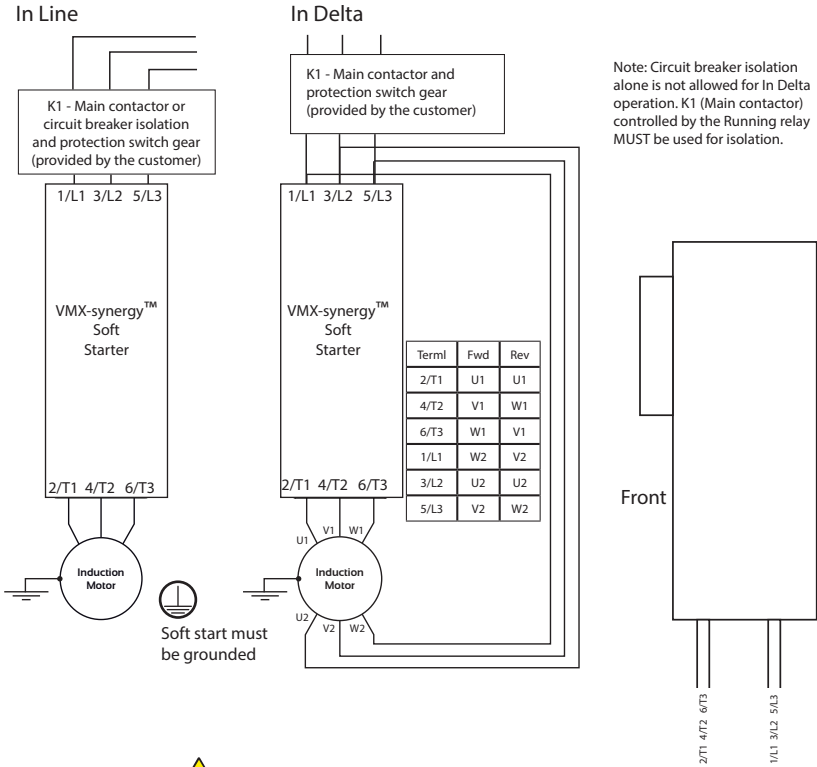

! For suitable short circuit protection devices (SCPD's) see short Circuit Protection in the Technical Information/ standards section of this guide.

! In Delta
For this configuration applying the equation.
 $VMX-synergy^{TM} I_e = I_e (motor) / \sqrt{3}$

Allows lower current rating VMX-synergy™ than the motor.

When In Delta configuration is used a line contactor controlled by VMX-synergy™ MUST be used with the In Delta Firing Mode selected in the advanced menu.

Fan Electrical Supply

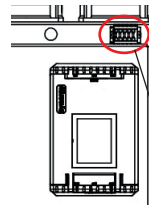

! The cooling fans are of fixed voltage (defined at the time of order), and require a separate electrical connection (110Vac or 230Vac). The required fan rating is shown on the label (see below)

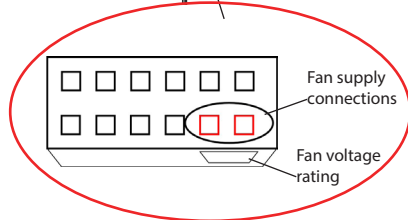

Wiring connection



3 Wire Control Diagram
110/230Vac control supply (U_c)
and digital input (U_i) programming.

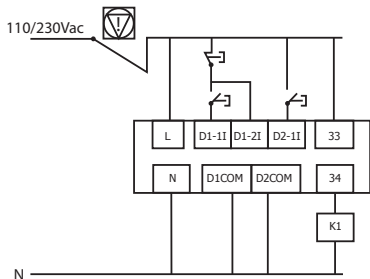

3 wire Control Diagram 24Vdc control supply (U_c)
and digital input (U_i) programming.

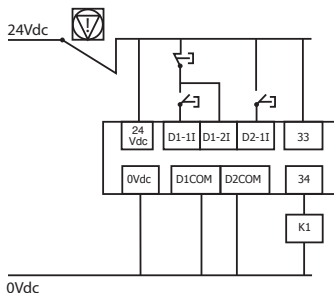

Digital input programming

D1 - 1I = Start
D1 - 2I = Stop
D2 - 1I = Reset

	CAUTION
#1	REFER TO TABLE 1 on page 6 for input control voltages. These recommended wiring diagrams are specifically where the control supply voltage (U_c) is identical to the control circuit voltage (U_i) and not to be supplied separately. Other wiring configurations must also be in accordance with existing local and national codes and regulations.
#2	Power factor correction capacitors must NOT be positioned between the soft start and the motor or there is a risk of damaging thyristors due to current peaks.

110/230Vac (U_c) and (U_i) user programmable control diagram

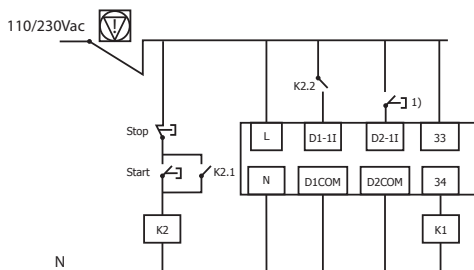

24Vdc (U_c) and (U_i) user programmable control diagram.

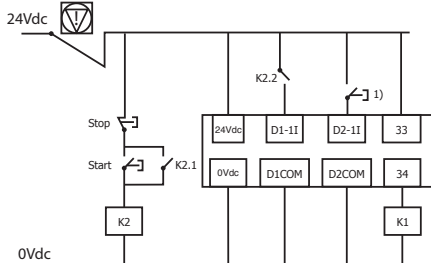

User programmable Inputs are fully programmable

D1 - 1I = High Start / Low Stop
D1 - 2I = None
D2 - 1I = High Reset

1) Optional high reset. If this reset is required ensure "User Programmable" is selected in the control method menu found in the Digital Inputs menu. If you would prefer the reset to work by removing and reapplying the Start Signal on D1 - 1I then select "Two wire control" in the control method menu.

Soft start motor reversing circuit



Below is a soft start reversing circuit without soft stop, it shows the main components required. You must follow your local wiring and electrical regulations when constructing this circuit, set to 'User Programmable' control.

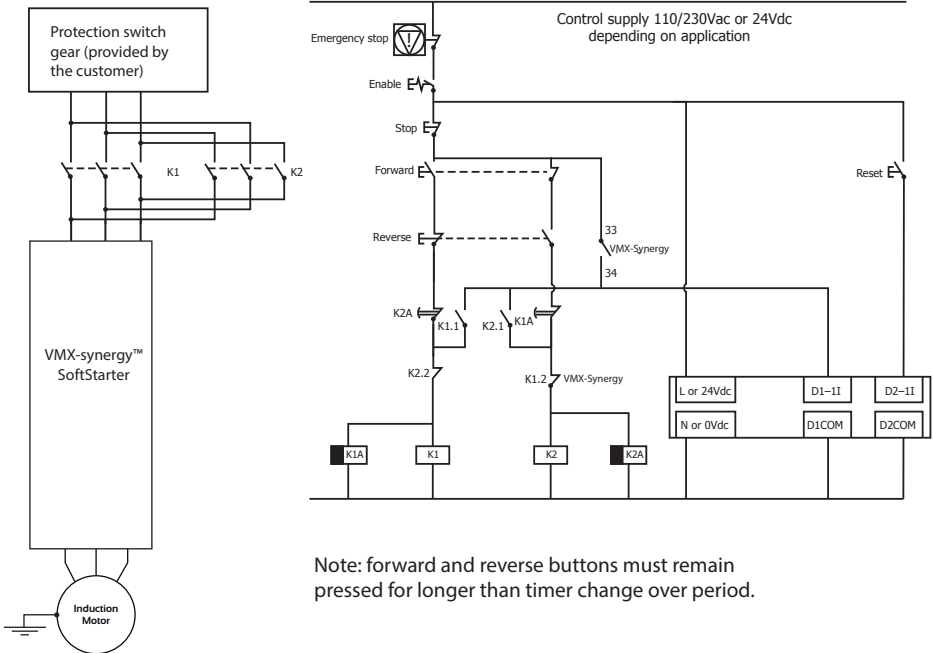

Note: forward and reverse buttons must remain pressed for longer than timer change over period.

CAUTION

REFER TO TABLE 1 on page 6 for input control voltages.

Item	Description
K1, K2	AC3 rated forward/reverse contactors
K1A, K2A	1 second drop out delay timers
VMX-synergy™	VMX-synergy™ soft start

These are the major components of the system. Local wiring regulations should be observed. Note the use of timers to ensure that a reversed voltage is not applied to the starter/motor before the motor field has had some chance to die away.

The thermal capabilities of VMX-synergy™ should be considered.

Sequential Soft Start diagram

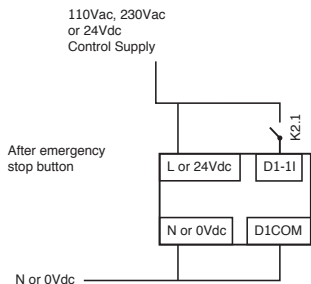

CAUTION

REFER to TABLE 1 on page 6 for input control voltages.

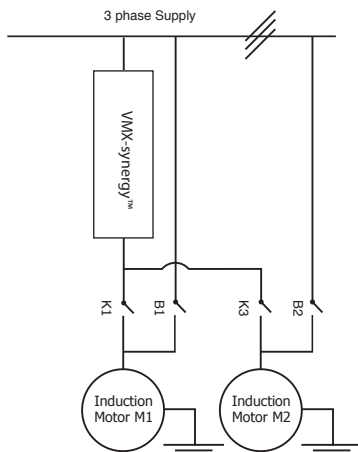

110Vac, 230Vac or 24Vdc Control Supply

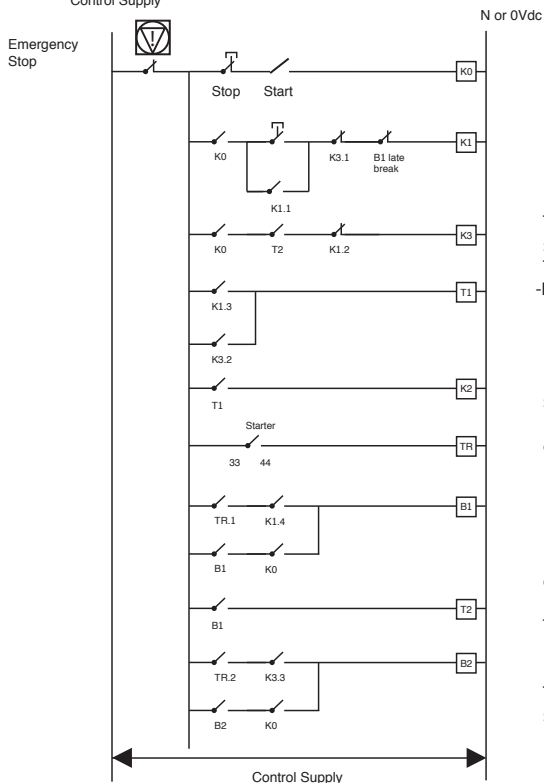

Notes

Soft Starter must have stop time set to 0
 T1 Time between K1 or K3 closing and the starter being energised - 0.5 sec minimum.
 T2 Time between B1 closing and K3 closing -Dependant on application - 0.5 sec minimum.

Set to 'Two wire control'

Emergency stop switch cuts off control supply and drops out starter and motors.
 Stop switch drops control supply from contactors and timers stopping both motors.
 Start switch initiates softstart then bypass of motor 1 immediately followed by softstart then bypass of motor 2.

Soft Starter must be rated for combined starting duty.

The control logic can be continued for more motors.

The thermal capabilities of VMX-synergy™ should be considered.

Current Transformer Installation **VMX-synergy™**

Current Transformers are supplied separately and must be fitted externally.

The unit has the current transformer (CT) cables pre-installed, colour coding corresponds to the phase wiring identification.

Attach the CT cables to the transformers adhering to the numbering scheme.



If the motor overload function is required when the unit is configured for external bypass operation, the current transformer must be placed outside the bypassed circuit.

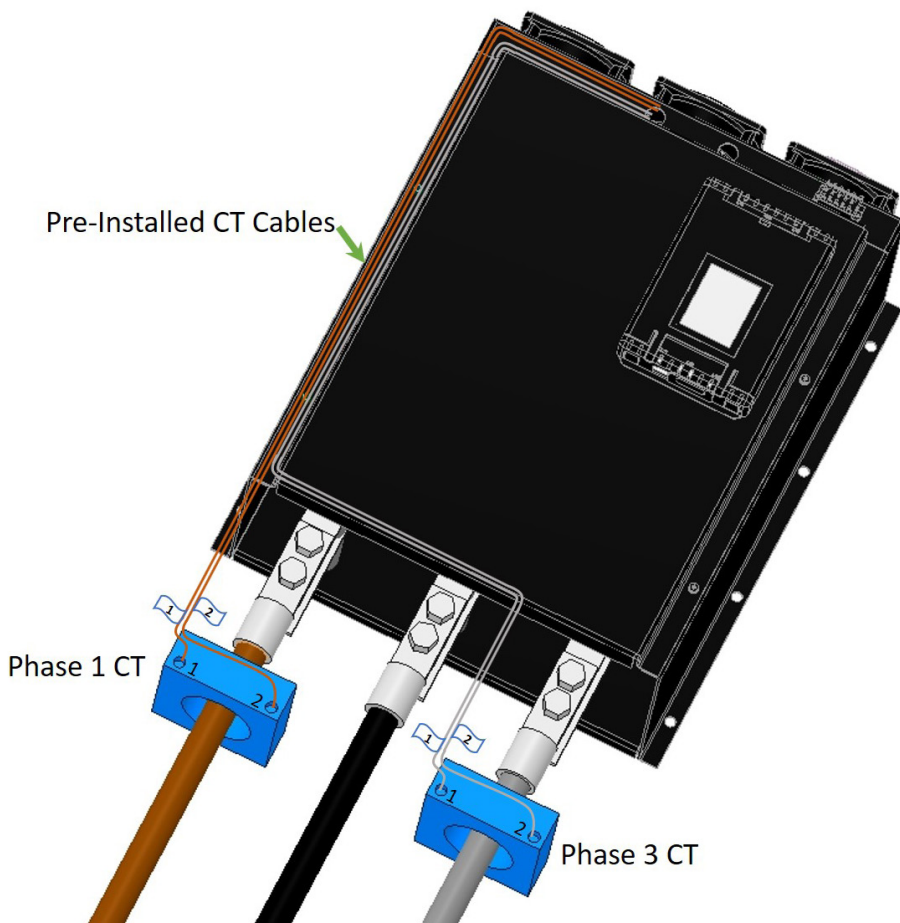

External Bypass

VMX-synergy™

A separate, correctly rated AC53 bypass contactor may be used to provide thyristor bypass. The contactor must be connected in parallel with the VMX-synergy™ starter as shown in the diagrams below.

Soft-Starting and Soft-Stopping remain active as normal. At the completion of the starting ramp a bypass contactor is closed, effectively removing the thyristors from circuit, which in turn eliminates heating losses.

The contactor is controlled by a programmable relay set to 'End of Start' (terminal 44), ensuring that bypassing occurs only after completion of the start, and the motor terminal voltage is at supply voltage.

Power Circuit Diagram

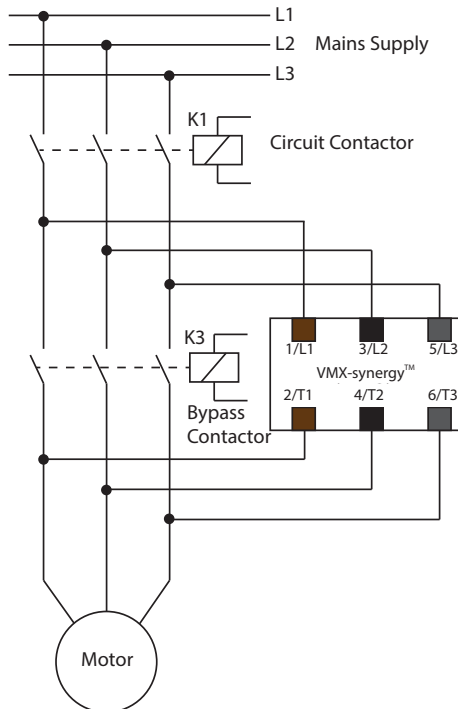

External Bypass

Control Circuit Diagrams

3 Wire Control Diagram 110/230Vac control supply (U_g) and digital input (U_c) programming. Bypass control

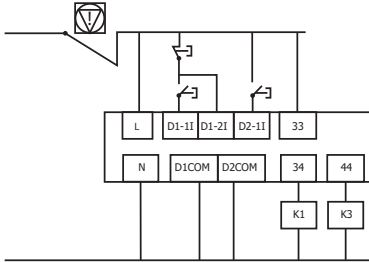

3 wire Control Diagram 24Vdc control supply (U_g) and digital input (U_c) programming. Bypass Control

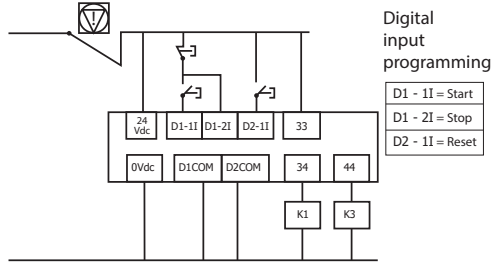

24Vdc (U_g) and (U_c) user programmable control diagram. Bypass control

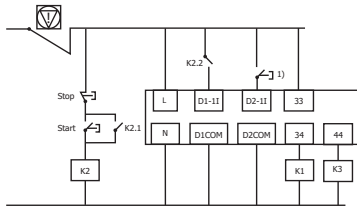

110/230Vac (U_g) and (U_c) user programmable control diagram. Bypass Control

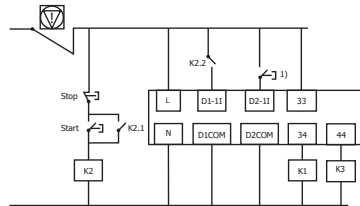

CAUTION

REFER to TABLE 1 on page 6 for input control voltages.

Programming

VMX-synergy™

1. Setup Wizard

2. Select Your Application

3. Select Your Application

4. Set Motor Current Rating

5. Select Control Method

6. Select Digital Input Voltage

7. Auto Setup Summary

8. Motor status screen

Please note:
Only appears if application with a trip class higher than 10 is selected

Rating table



Type	IEC, I _e	kW ¹⁾		UL, FLA	HP ²⁾				Control supply U _s
	A ³⁾	230V	400V	A ⁴⁾	200V	208V	220-240V	440-480V	
VMX-SGY-401-4-XX	610	200	355	590	200	200	200	500	24Vdc or 110Vac or 230Vac
VMX-SGY-403-4-XX	722	220	400	722	250	250	300	600	
VMX-SGY-501-4-XX	850	280	500	840	300	300	350	700	
VMX-SGY-503-4-XX	960	315	560	960	300	350	400	800	
VMX-SGY-505-4-XX	1080	355	630	1080	350	400	450	900	

- 1) Rated operational powers in kW according to IEC 60072-1 (primary series) corresponding to IEC current rating.
- 2) Rated operational powers in HP ased on Table 430.250 of the National Electrical Code, 2005[®] corresponding to FLA current rating.
- 3) The IEC, I_e rating will apply for EN 60947-4-2 max rating index 1080A: AC-53a: 3.5-17: 60-3
- 4) Ratings apply for a maximum surrounding air temperature of 40°C.

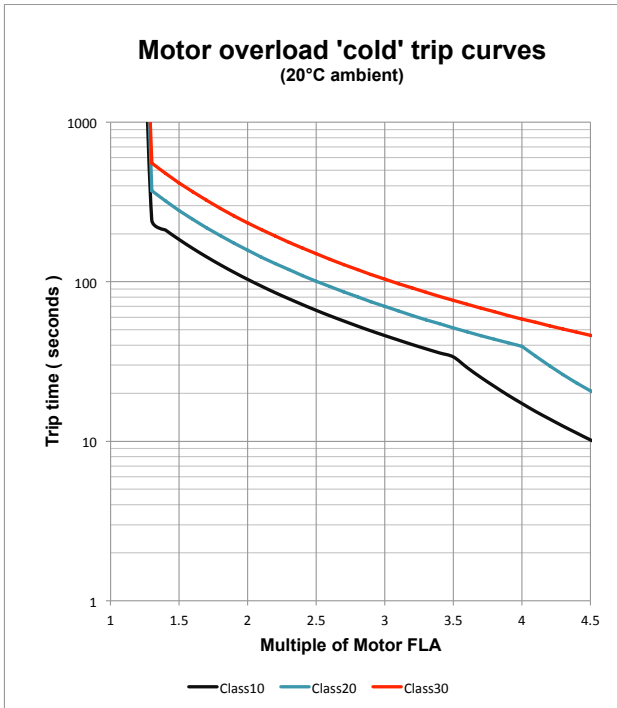

* Please note: When the overload has tripped there is a forced cooling time to allow the overload to recover before the next start.

Technical information /Standards

VMX-synergy™

Rated operational voltages	U_e	200Vac to 480Vac	
Rated operational current	I_e	See Rating table	
Rating index		VMX-SGY-401 to VMX-SGY-505	le: AC-53a: 3.5-17: 60-3
Rated frequency		50 to 60Hz	
Rated duty		Uninterrupted	
Form designation		Form 1	
Rated insulation voltage	U_i	480V	
Rated impulse withstand voltage	U_{imp}	Main circuit	4kV
		Control supply circuit	2.5kV
IP code		Main circuit	IP00
		Supply and control circuit	IP 20
Pollution degree		2	
Rated conditional short-circuit current and type of co-ordination with associated short circuit protective device (SCPD).		Type 1 co-ordination. See short circuit protection table for rated conditional short-circuit current and required current rating and characteristics of the associated SCPD	
Rated control circuit voltage (programmable)	U_c	24Vdc, 110Vac or 230Vac	Protect with 4A UL Listed fuse
Rated control supply voltage	U_s	See Rating table, 2 Amp supply (continuous).	
Relay specification		AC-15 230Vac, 1A DC-13 30Vdc, 0.7A	
EMC Emission levels	EN 55011	Class A ⓘ	
EMC Immunity levels	IEC 61000-4-2	8kV/air discharge or 4kV/contact discharge	
	IEC 61000-4-3	10 V/m	
	IEC 61000-4-4	2kV/5kHz (main power and ports)	
		1kV/5kHz (signal ports)	
	IEC 61000-4-5	2kV line-to-ground 1kV line-to-line	
IEC 61000-4-6	10V		
Humidity		Max. 85% non-condensing, not exceeding 50% at 40°C	
ⓘ NOTICE: This product has been designed for environment A. Use of this product in environment B may cause unwanted electromagnetic disturbances, in which case the user may be required to take adequate mitigation measures.			

Standards

VMX-synergy™



-20°C (-4°F) to 40°C (104°F). Above 40°C de-rate linearly by 2% of VMX-synergy™ I_e per °C to a maximum of 60°C (140°F).



Altitude above sea level 1000m (3281ft). Above 1000m de rate by 1% of VMX-synergy™ I_e per 100m (328ft) to a maximum altitude of 2000m (6562ft).

Please note for higher temperatures (>60°C) and altitudes (>2000m) contact your supplier.

Short circuit protection

#1 Suitable for use in a circuit delivering not more than I_q rms Symmetrical Amperes, 480 Volts maximum, when protected by Class J time delay fuses with a maximum rating of Z1 or by a circuit breaker with a maximum rating of Z2 as in table below.

#2 Correctly selected semiconductor fuses can provide additional protection against damage to the VMX-synergy™ unit (this is sometimes referred to as type 2 co-ordination). These semiconductor fuses are recommended to provide this increased protection

Type designation			VMX-SGY 401	VMX-SGY 403	VMX-SGY 501	VMX-SGY 503	VMX-SGY 505
Rated operational current	I _e	A	610	722	850	960	1080
Rated conditional short circuit current	I _q	kA	30	30	42	42	42
Semiconductor fuse (class aR) #2	Type	A	Bussmann 170M5466 Siba 2067132.1000A		Bussmann 170M6467 Siba 2068132.1400A		
	Fuse rating	A	1000		1400		

Wire sizes and torques

Terminal		Models (VMX-SGY)	Wire Size		Torque	
			mm ²	AWG	Nm	lb-in
Main Terminals Copper busbar	2 x M10 bolt	401 to 403	50 x 10	1.5in x 0.5in	14	123
	M12 bolt	501 to 503	60 x 10	2.0in x 0.5in		
		505	80 x 10	2.5in x 0.5in		
Control terminals		All models	0.2-1.5	24-16	0.5	4.5
Protective Earth ¹⁾ Cu Only	M8 stud	401 to 403	≥ 70	≥ 1/0	12	105
	M10 stud	501 to 503	≥ 70	≥ 2/0		
		505	≥ 95	≥ 3/0		

1) Protective Earth wire size based on bonding conductor requirements of UL508 and UL508A and CSA C22. No.14

VMX-synergyTM

Quick Start Guide

(E) Electric current! Danger to life!

Only skilled or instructed persons may carry out the operations.

(D) Lebensgefahr durch Strom!

Nur Elektrofachkräfte und elektrotechnisch unterwiesene Personen dürfen die im Folgenden beschriebenen Arbeiten ausführen.

(F) Tension électrique dangereuse!

Seules les personnes qualifiées et averties doivent exécuter les travaux ci-après.

(E) ¡Corriente eléctrica! ¡Peligro de muerte!

El trabajo a continuación descrito debe ser realizado por personas cualificadas y advertidas.

(I) Tensione elettrica: Pericolo di mortal!

Solo persone abilitate e qualificate possono eseguire le operazioni di seguito riportate.

(中) 触电危险!

只允许专业人员和受过专业训练的人员进行下列工作。

(R) Электрический ток! Опасно для жизни!

Только специалисты или проинструктированные лица могут выполнять следующие операции.

(N) Levensgevaar door elektrische stroom!

Uitsluitend deskundigen in elektriciteit en elektrotechnisch geïnstrueerde personen is het toegestaan, de navolgend beschreven werkzaamheden uit te voeren.

(B) Livsfare på grund af elektrisk strøm!

Kun uddannede el-installatører og personer der er instruerede i elektrotekniske arbejdsopgaver, må udføre de nedenfor anførte arbejder.

(G) Προσοχή, κίνδυνος ηλεκτροπληξίας!

Οι εργασίες που αναφέρονται στην συνέχεια θα πρέπει να εκτελούνται μόνο από ηλεκτρολόγους και ηλεκτροτεχνίτες.

(P) Perigo de vida devido a corrente eléctrica!

Apenas electricistas e pessoas com formação electrotécnica podem executar os trabalhos que a seguir se descrevem.

(S) Livsfara genom elektrisk ström!

Endast utbildade elektriker och personer som undervisats i elektroteknik får utföra de arbeten som beskrivs nedan.

(I) Hengenvaarallinen jännitel!

Vain pätevät sähköasentajat ja opastusta saaneet henkilöt saavat suorittaa seuraavat työt.

(S) Nebezpečí úrazu elektrickým proudem!

Níže uvedené práce směji provádět pouze osoby s elektrotechnickým vzděláním.

(E) Eluoltlik! Elektrilöögloht!

Järgnevalt kirjeldatud töid tohib teostada ainult elektriala spetsialist või elektrotehnilise instrueerimise läbinud personal.

(H) Életveszély az elektromos áram révén!

Csak elektromos szakemberek és elektrotechnikában képzett személyek végezhetik el a következőkben leírt munkákat.

(V) Elektriská stráva aprauda dzīvībai!

Tālāk aprakstītos darbus drīkst veikt tikai elektro speciālisti un darbam ar elektrotehnikām iekārtām instruetās personas!

(L) Pavojus gvybei dēl elektros srovės!

Tik elektrikai ir elektrotehnikos specialistai gali atlikti žemiau aprašytus darbus.

(P) Porażenie prądem elektrycznym stanowi zagrożenie dla życia!

Opisane poniżej prace mogą przeprowadzać tylko wykwalifikowani elektrycy oraz osoby odpowiednio poustruowane w zakresie elektrotechniki.

(S) Življenjska nevarnost zaradi električnega toka!

Spodaj opisana dela smejo izvajati samo elektro strokovnjaki in elektrotehnično poučene osebe.

(SK) Nebezpečnost ohrozenia života elektrickým prúdom!

Práce, ktoré sú nižšie opísané, smú vykonávať iba elektroodborníci a osoby s elektrotechnickým vzdelaním.

(B) Опасност за живота от электрически ток!

Операциите, описани в следващите раздели, могат да се извършват само от специалисти-електротехници и инструктиран електротехнически персонал.

(T) Atenție! Pericol electric!

Toate lucrările descrise trebuie efectuate numai de personal de specialitate calificat și de persoane cu cunoștințe profunde în electrotehnică.

California Customers: California Proposition 65 Warning

WARNING: this product and associated accessories may contain chemicals known to the State of California to cause cancer, birth defects, or other reproductive harm.

For more information visit <https://p65warnings.ca.gov>





SCATTERGOOD & JOHNSON LTD

ELECTRICAL ENGINEERING & FLUID CONTROL DISTRIBUTORS

Est.1899

At Scattergood & Johnson Ltd, we pride ourselves on being a technical distributor to specialist industries.

Working with a range of quality product suppliers across a number of specialist markets, we are not your average 'box shifter' - we are your technical and supply chain partner.

We fully support every product we sell - for free! Our internal team and external sales engineers can answer any product or application question, no matter the complexity.

Backing up this technical ability is a range of 50,000+ products available from stock for nationwide next day delivery (same day if required!), or you can collect what you need from any of our trade counters around the UK.

Select your specialist interest below to learn more about how we can help.



Online, In Branch and On the Road - Scattergood & Johnson Ltd, there when you need us.

www.scatts.co.uk