

MECHAN CONTROLS

CODEX™

SAFETY SWITCH

INSTALLATION GUIDE

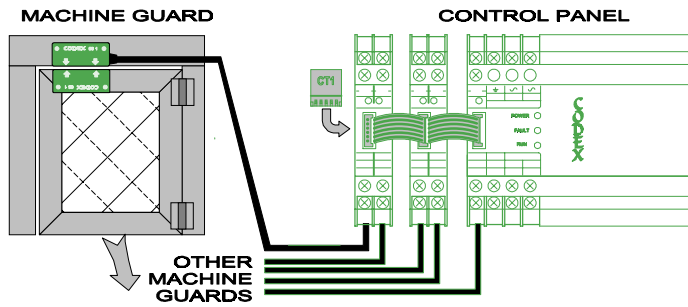

This information is designed to help suitably qualified personnel install and operate Mechan Safety Switch equipment. Before using this product, read this guide thoroughly along with any relevant European and/or National standards e.g. Machinery Directive 89/392/EEC and it's amendments, Provision and Use of Work Equipment Regulations. Further information can be obtained from Mechan Controls Limited

***** KEEP THIS GUIDE FOR FUTURE REFERENCE *****

CONTENTS

- | | |
|--------------------------|---|
| 1 Description | 4 Connections |
| 2 Product Identification | 5 Technical Specification - Control Modules |
| 3 System Assembly | 6 Technical Specification - Safety Switches |

1)

DESCRIPTION

The CODEX Safety System is a purely electronic means of monitoring machine guards, comprising of a Control Unit and Safety Switches. The CODEX system uses both Dynamic Signal Processing and Dual Channel/Cross Monitoring techniques to provide a Fail-Safe system which may be used in either single or dual channel control circuits.

The SENSORS: Are solid state electronic devices with no magnets, contacts or moving parts. They are resin encapsulated into an ABS case to provide a fully sealed, IP67, sensor which can withstand the most arduous of conditions. Water, dust, oil, machine vibration and even steam cleaning have little or no effect on their performance.

The CODEX Safety Switches differ from existing Mechan systems in that the actuator (moving sensor) transmits a code to the control module to be decoded. This code can be changed during manufacture to provide **uniquely** coded sensors, which can provide additional security or be used as 'Electronic Key' systems. (See additional information in CM9/CX9/CS9 installation guide)

The CONTROL MODULES: All systems start with the CM1. This contains the power supply regulation, dual PGC relay outputs, the external re-set/proving circuit and system indication along with the input for one safety switch sensor and it's volt free indicator output. The CM1 and a CS type safety switch are all that is required for a system monitoring one guard. For larger systems, simply connect the required number of one or two channel extender modules, CX1 or CX2, to the CM1. The extenders modules provide connections for the safety switch inputs, and a volt free indicator output.

2)

PRODUCT IDENTIFICATION

2a) CM1

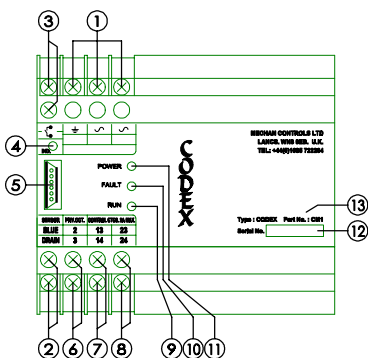

2b) CX1

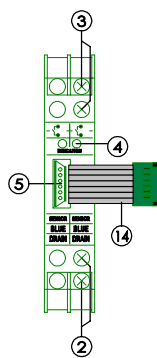

2c) CX2

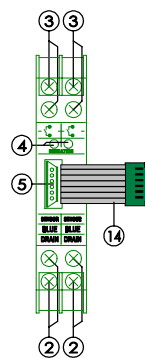

2d) CS1 / CS2 / CS3

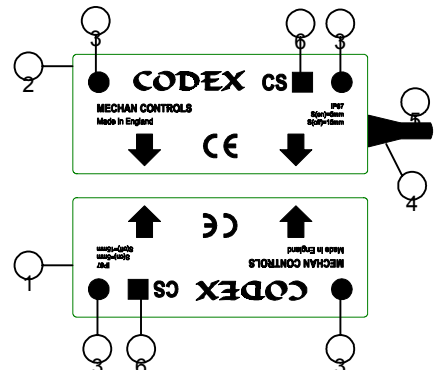

CONTROL MODULES

- 1* Power supply input (see label)
options 24,110 or 230Vac or 24Vdc
- 2 Safety switch Sensor Input
- 3 Indicator Output (n/o volt free contact)
- 4 Gate Open Indicator (Red LED)
- 5 Control Bus
- 6* External monitoring circuit / re-set circuit
- 7* Control Output No. 1 (volt free contact)

- 8* Control Output No.2 (volt free contact)
- 9* Run Indicator (Green LED)
- 10* Fault Indicator (Red LED)
- 11* Power On Indicator (Red LED)
- 12 Serial Number (See side of CX1/CX2)
- 13 Part Number (See side of CX1/CX2)
- 14** Control Bus Connector Strap

* = CM1 only; **=CX1/CX2 only

SAFETY SENSORS

- 1 Safety sensor oscillator (Moving part)
- 2 Safety sensor receiver (Fixed part)
- 3 Fixing holes
- 4 Cable protection grommet
- 5 Cable encapsulated into the sensor
- 6 Sensor type number

Mechan Controls Limited

Electronic Safety Switches

MECHAN CONTROLS LIMITED, 14/16 SEDDON PLACE, STANLEY INDUSTRIAL ESTATE, SKELMERSDALE, LANCASHIRE, WN8 8EB
Tel : + 44 (0)1695 722264 Fax : + 44 (0)1695 729664 WEB : www.mechancontrols.co.uk EMAIL : technical@mechancontrols.co.uk

3) SYSTEM ASSEMBLY

3a) CLIP ON TO DIN-RAIL

The CODEX control modules are designed to be mounted in an IP 55 (minimum) cabinet.

The modules clip on to standard 35mm symmetric (Top Hat) DIN-rail.

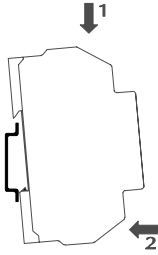

3b) SINGLE GUARD SYSTEM

A system to monitor only one guard requires the CM1 control module mounted in suitable cabinet and one pair of safety switch sensors.

The 'Control Bus' terminator CT1 must be connected to the CM1 as shown

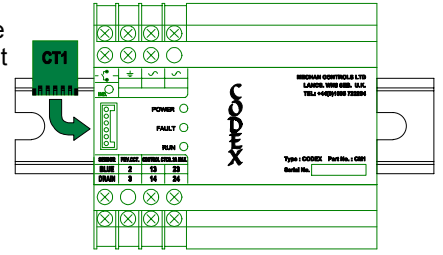

3c) MULTI GUARD SYSTEMS

Most systems will require the monitoring of more than one guard. Assemble the required number of modules on a DIN-rail starting with the CM1 and clipping the extender modules, CX1 or CX2, to the left of the CM1.

The 'Control Bus' straps connect to the adjacent, right hand module as shown. The maximum number of channels for a DC supply system is 30, AC systems can have up to 29 channels but will require a Power Boost unit after each additional ten channels(see PB10 guide)

The 'Control Bus' terminator CT1 must be connected to the last module.

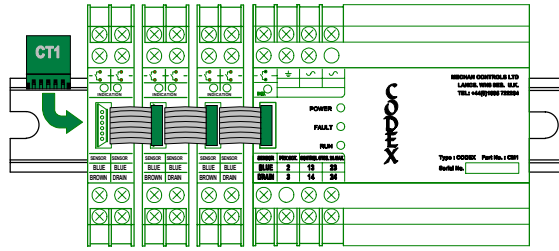

3d) REMOVAL FROM DIN-RAIL

To remove the modules gently lever out the DIN clip with a small screwdriver as shown (1). Tilt the unit in the direction (2) and slip off the DIN-rail (3).

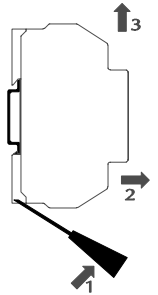

3e) MOUNTING SAFETY SWITCH SENSORS

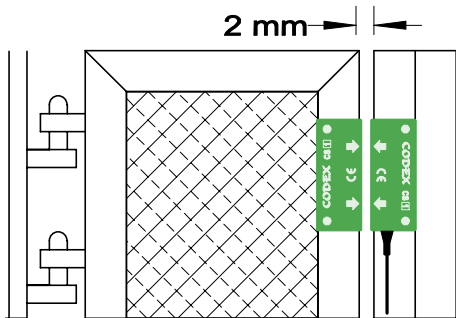

CODEX safety switch sensors have 2 pre-drilled fixing holes. (see back page for dimension / position details)

! DO NOT enlarge the fixing holes.

Mount the Safety Switch Sensors as shown (left), with the arrows aligned, the printed faces of the sensors facing away from the machine frame and a gap of approximately 2 mm. between the sensors when the guard is closed.

This gives a good level of lateral tolerance to allow for 'gate sag' and freedom from nuisance tripping due to machine / guard vibration.

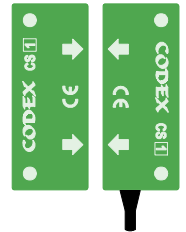

CABLE CONNECTION / EXTENSION

The CODEX fixed sensor has 5, 10 or 15 metres of cable potted into it when supplied. This ensures a completely water-tight seal to the electronics within the sensor. Run the cable back to the control unit through cable protection (if required) and terminate into the appropriate input channel, following the colour coding of the wires to the labels on the input terminals.

NOTE:

- 1) The sensor cable may be extended if required using a similar type screened cable.
- 2) Cable runs of up to 200 metres will not significantly affect performance.
- 3) Cable joints should be moisture proof and NOT EARTHED. The only earth connection must be via the drain terminal.

TREAT AS INSTRUMENT CABLES AND KEEP SEPARATE FROM POWER CABLES (150mm separation is normally adequate)

CX1 SENSOR CONNECTION

CX2 SENSOR CONNECTION

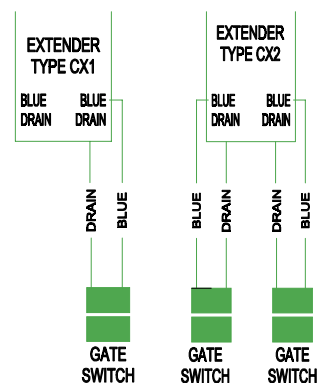

GATE CLOSING

The moving sensor may approach the fixed sensor from any direction. When the guard is closed the arrows must be aligned and facing each other.

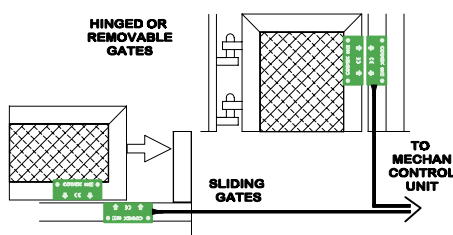

CODEX sensors are suitable for use on hinged, sliding or removable guards.

TEMPERATURE

CODEX safety switches can operate in temperatures from -20° to +50°C. Heads may be mounted to a hot surface, using nylon spacers and screws as shown. Maximum cable temperature 60°C.

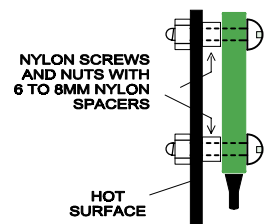

4)

CONNECTIONS

4a) SINGLE CHANNEL CONTROL CIRCUITS

POWER SUPPLY

- 1 The CM1 base module is available to suit 24 / 110 / 240Vac (+/- 10%, 6VA), and 24Vdc. Specify the voltage when ordering.
- 2 For 24Vdc systems the supply must be regulated +/- 5% and the negative must be at earth potential.
- 3 The CM1 must be connected to a 'Clean' local earth.

RE-SET / PROVING

- 1 In single control channel systems, a momentary, normally open re-set button should be connected across terminals 2 and 3.
- 2 Use screened cable for the Re-set/Proving circuit.

INDICATION

- 1 The indicator contacts are normally open. When a guard is opened the indicator contact for that channel closes, the guard open LED will also illuminate. (These contacts are for indication only)

CONTROL CONTACTS

- 1 The CM1 has two positively guided, N/O control contacts brought out to terminals, 13,14; and 23,24.
- 2 The relay contacts have a maximum 2A rating and the supply to be switched should be fused.
- 3 In single control channel systems the control contacts should be linked in series.

SYSTEM OPERATION

- 1 When power is applied to the control module, the RED POWER LED and RED FAULT LED will illuminate.
- 2 If all the monitored machine guards are closed and the RE-SET button is pressed the RED FAULT LED will be extinguished and the GREEN RUN LED will illuminate. The control relays are then energized and the contacts on terminals 13,14 / 23,24 will be closed.
- 3 K1 can be energized using the start button.
- 4 K1 will be de-energized if: a) A Stop Button (or Emergency Stop Button) is pressed. b) A monitored guard is opened. or c) Power to the CM1 is lost.
- 5 When the guards have been closed and the re-set button pressed, the CM1 control relays will be energised closing the contacts on terminals 13,14 and 23,24. This will allow K1 to be operated via the Start and Stop buttons.

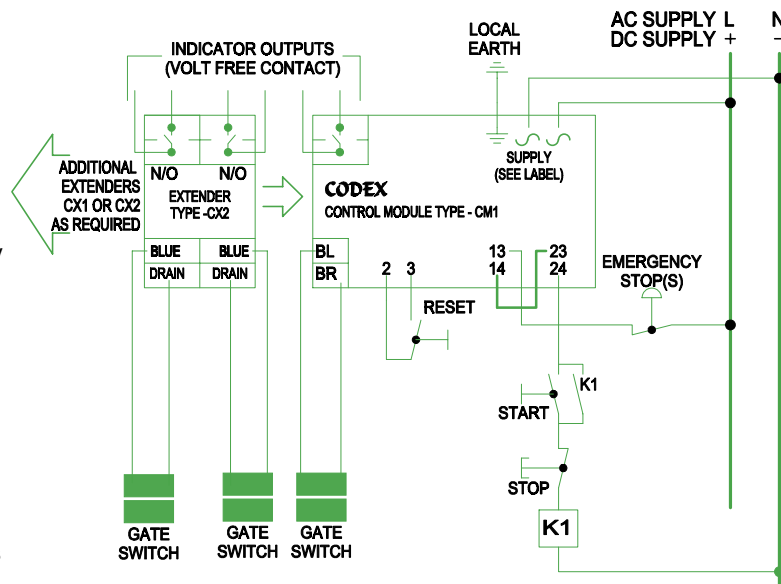

NOTES

- 1) The last extender module must have the CT1 terminator plug.
- 2) 30 Channels max. for DC supplied systems.
- 3) 9 Channels max. for AC systems, Up to 29 max with PB10 (See PB10 instructions for larger AC systems.)

4b) DUAL CHANNEL CONTROL CIRCUITS

POWER SUPPLY

- 1 See Above

RE-SET / PROVING

- 1 In dual control channel systems, the re-set / proving circuit (terminals 2 & 3) are used not only as a re-set function (as above) but also to monitor the main contactors / starters K1 & K2.
 - 2 Link normally closed contacts on K1 and K2 in series with the re-set button and terminals 2 & 3.
 - 3 This ensures that the CM1 can only be re-set if both K1 and K2 are de-energized.
 - 4 Use screened cable for the Re-set/Proving circuit.
- NOTE: K1 & K2 should have positively guided contacts

CONTROL CONTACTS

- 1 The CM1 has two positively guided, N/O control contacts brought out to terminals, 13,14; and 23,24.
- 2 The relay contacts have a maximum 2A rating and the supply to be switched should be fused.
- 3 In dual control channel systems the control contacts, terminal 13,14 and 23,24 should be used individually to switch two separate contactors / starters.

SYSTEM OPERATION

- 1 System operation for a dual channel control is exactly the same as the single channel control.
- 2 An additional level of safety is achieved by duplicating the control channels. If a fault occurs in either channel (i.e. K1 or K2 welds) the other channel will be de-energised when the stop button is pressed or a guard is opened, thus maintaining the safety function.
- 3 When all gates have been closed and the CM1 requires a re-set, the proving circuit, terminals 2 & 3 will prevent a re-start as the normally closed contact on the welded relay will not be made. The RED FAULT LED will be illuminated.

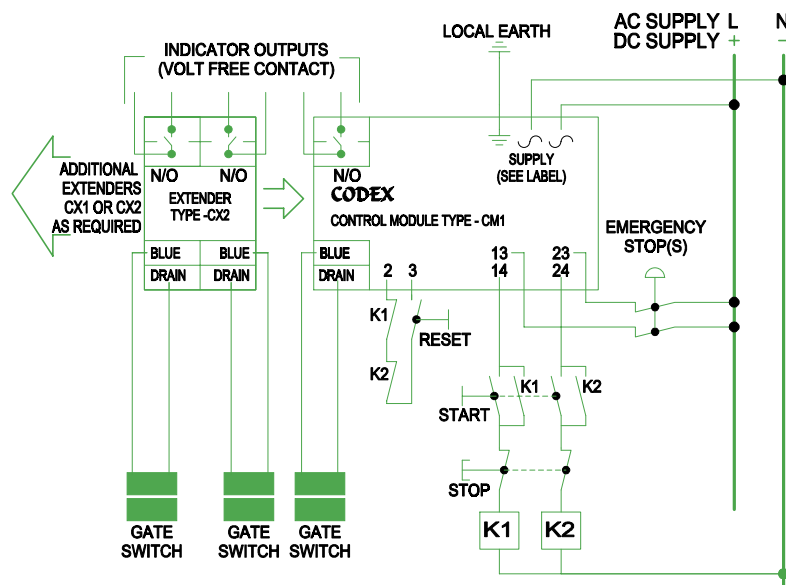

NOTES

- 1) The last extender module must have the CT1 terminator plug.
- 2) 30 Channels max. for DC supplied systems.
- 3) 9 Channels max. for AC systems, Up to 29 max with PB10 (See PB10 instructions for larger AC systems.)

5) **TECHNICAL SPECIFICATIONS**

5a) CONTROL MODULES - TYPE CM1

Part Number	CM1
Supply Voltages	230/110/24Vac or 24Vdc
Consumption	AC=6VA; DC=100mA + 20 mA/Channel
Max. Switching Capacity	2A/240Vac or 2A/30Vdc
Protection	IP20
Dimensions	90 x 105 x 59 mm
Fitting	35 mm DIN Rail
Operating Temp.	0° to 45°C (storage temp -20° to 50°C)
System Indication	Power, Run & Fault LED's
Channel Indication	1 x Red LED & 1 x N/O contact (0.5A @ 125Vac / 1A @ 30Vdc res.)

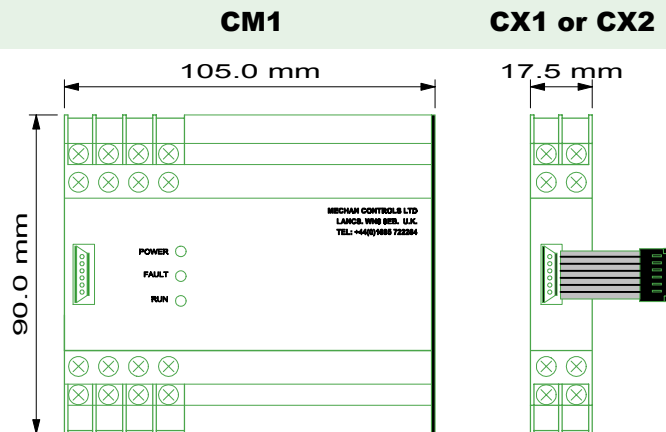

5b) EXTENDER MODULES - TYPE CX1/CX2

Part Number	CX1	CX2
Protection	IP20	IP20
Dimensions	90 X 17.5 X 59 mm	90 X 17.5 X 59 mm
Fitting	35 mm DIN Rail	35 mm DIN Rail
Operating Temp.	0° to 45°C	0° to 45°C
Storage Temp.	-20° to 50°C	-20° to 50°C
Channel Indication	1 x Red LED & 1 x N/O contact (0.5A @ 125Vac / 1A @ 30Vdc res.)	2 x Red LED & 2 x N/O contact (0.5A @ 125Vac / 1A @ 30Vdc res.)

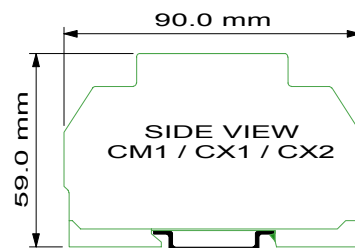

6a) SAFETY SENSORS - 'CS' TYPE

Part Number(s) CS1 /CS2 / CS3 (+ cable length i.e. 5m / 10m)

Construction	ABS Case; Resin filled
IP Rating	IP67
Fixing	2 x 5 mm diameter holes
Cable Type	Single + Foil Shield & Drain
Cable Lengths Available	5,10 & 15 metres (longer available to order)

Options

Part Number	-CS1	In-line fixing holes, with potted in cable
	CS2	Off-set fixing holes with potted in cable
	CS3	In-line fixing holes with IP67 connector for quick disconnect
	CS4	In-line fixing holes with IP67 connector for quick disconnect (USA)
	CS9	In-line fixing holes, with potted in cable. Unique code. Must have matching control module (see CM9/CX9/CS9 installation notes)

DIMENSIONS CS1 or 3 (In-line holes)

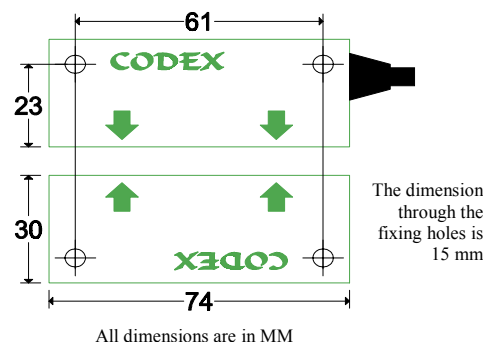

DIMENSIONS CS2 (Off-set holes)

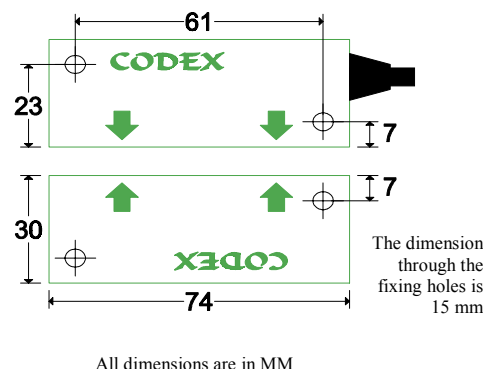

6b) GENERAL OPERATING SPECIFICATION FOR SENSORS

SWITCHING DISTANCE	7 to 10 mm (Must make 5 mm / Must Break 15 mm)
OPTIMUM GAP	2 mm
LATERAL TOLERANCE AT 2 mm GAP	8 mm
OPERATING TEMPERATURES	-20°C to 50°C (Short term 100°C; i.e. Hot hosing down is acceptable)
MAXIMUM CABLE LENGTH	100 metres, with some slight reduction in switching distance.



The CODEX Safety switch complies with all relevant Essential Health and Safety Requirements of the Machinery Directive (89/392/EEC & amendments 91/368/EEC, 94/44/EEC). The CODEX series has been independently tested to meet the 'Heavy Industrial' Specification of the EMC Directive for both emissions and immunity (BS EN 50081-2& 50082-2) The CE marking relates to the EMC Directive. Copies of the Certificate of Conformity can be obtained from Mechan Controls Limited



SCATTERGOOD & JOHNSON LTD

ELECTRICAL ENGINEERING & FLUID CONTROL DISTRIBUTORS

At Scattergood & Johnson Ltd, we pride ourselves on being a technical distributor to specialist industries.

Working with a range of quality product suppliers across a number of specialist markets, we are not your average 'box shifter' - we are your technical and supply chain partner.

We fully support every product we sell - for free! Our internal team and external sales engineers can answer any product or application question, no matter the complexity.

Backing up this technical ability is a range of 50,000+ products available from stock for nationwide next day delivery (same day if required!), or you can collect what you need from any of our trade counters around the UK.

Select your specialist interest below to learn more about how we can help.

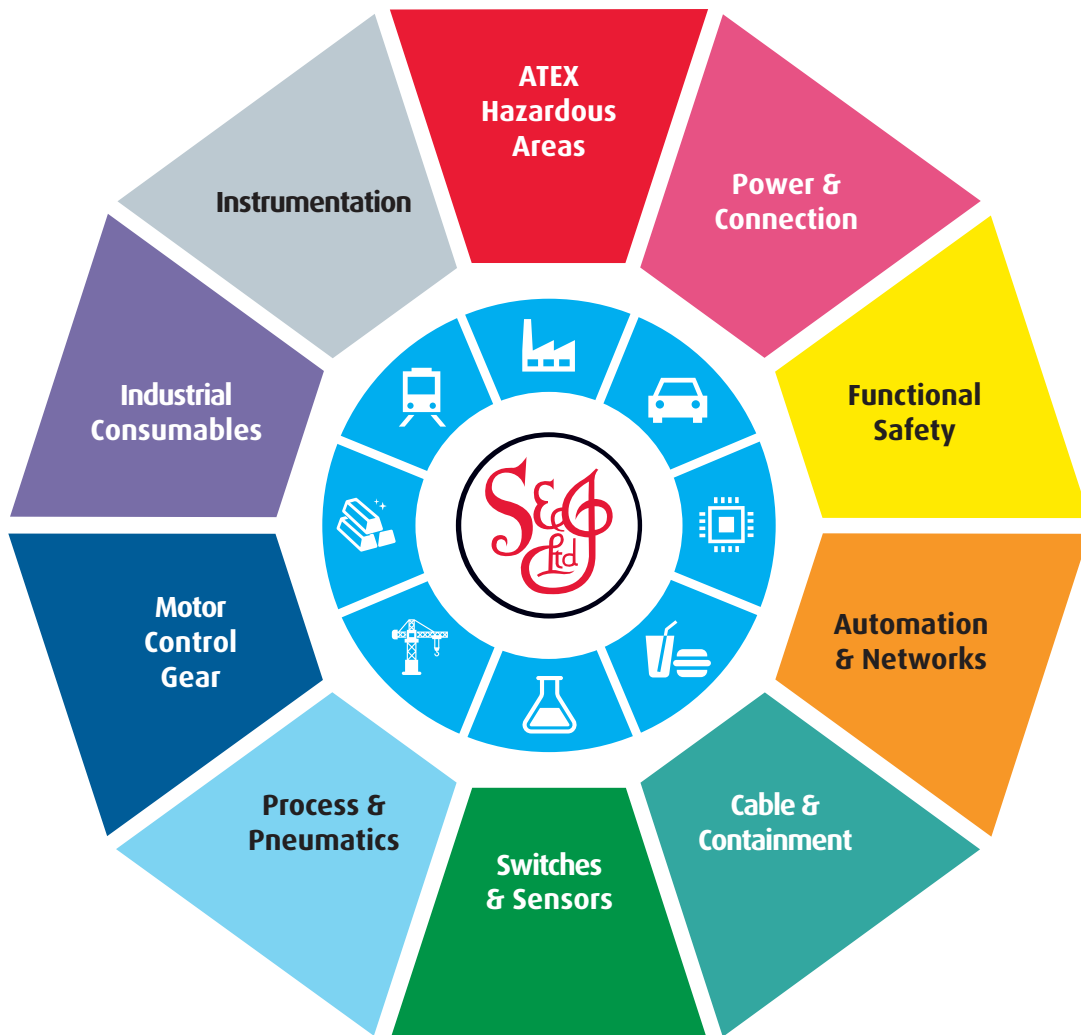

Online, In Branch and On the Road - Scattergood & Johnson Ltd, there when you need us.

www.scatts.co.uk