



KEEP THIS GUIDE FOR FUTURE REFERENCE

This information is designed to help suitably qualified personnel install and operate Mechan Safety Switch equipment.

Before using this product, read this guide thoroughly along with any relevant European and/or National standards e.g. Machinery Directive 89/392/EEC and its amendments, Provision and Use of Work Equipment Regulations.

Further information can be obtained from
Mechan Controls

Description

MAGNASAFE MS2 & MS3 safety switches are magnetically operated non-contact safety switches for use in machine guarding applications.

The MS2 & MS3 are manufactured in robust ABS housings, with both switch and actuator fully sealed to IP67 making them suitable for use in wet or dusty environments. The M18 and M30 barrel mount housings are easy to install and adjust, providing a simple reliable solution to machine guard interlocking. With correct installation, The MS2 & MS3 safety switches comply with the guidelines given in EN1088.

Operation

When the safety switch and actuator are within the specified operating range, the **Safety Contacts** will be closed and the **Auxiliary Contact** will be open (See table on page 3 for switching distances)

When the actuator moves out of the operating range, the **Safety Contacts** will open, the **Auxiliary Contact** will close for indication.

The MS2 & MS3 safety switches and actuators are designed to approach each other from most angles. When the switch is closed the targets on the printed face of the switch must be aligned.

Applications

Machinery guards where door locking is not required.
Food and Beverage packing/filling systems
Diary
Pharmaceutical
Paper Industry
Can Forming and Filling, (Aluminum, Steel, Plastic)
Semiconductor Manufacture/Assembly.

MS2 Safety Switch

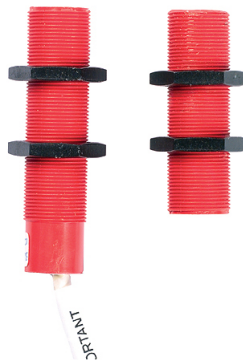

MS3 Safety Switch



Listed



Approvals

CE	Complies with the relevant sections of the CE marking directive.
UL	UL 508, Industrial Control Equipment

EUROPEAN DIRECTIVES

Machinery Directive 98/37/EC
Low Voltage Directive 73/23/EC
Electromagnetic Compatibility Directive 89/336/EC

EUROPEAN STANDARDS

EN292	Safety of Machinery Basic concepts, general principles for design.
EN 60204	Safety of Machinery Electrical equipment of machines.
EN 954-1	Safety of Machinery Safety related parts of controls systems
EN 1088	Interlocking devices associated with guards.
EN 60947-5-3	Safety of Machinery Specification for low voltage switchgear and control gear.

Declaration Conformity

A Declaration of Conformity may be obtained from Mechan Controls PLC, Tel +44(0)1695 722264 or from the Mechan Web Site at www.mechancontrols.co.uk

Mounting

The MS2 & MS3 safety switches can approach each other from most angles. When the guard is closed the targets on the printed face of the switch and actuator must be aligned.

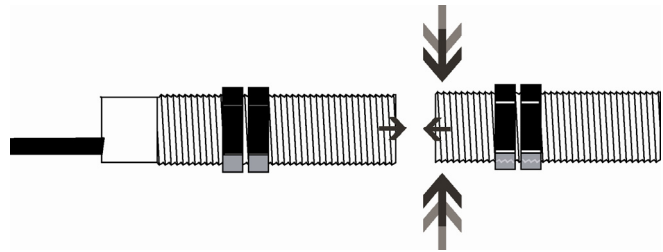

Mount the switch on to the machine frame and the Actuator on to the opening edge of the door. Always try to mount the switch on non-ferrous material. (*Ferrous materials may reduce the switching distance.*)

Do not use the safety switch as a door stop.

Leave a minimum of 50 mm between any adjacent switches.

EN 1088 Provides some mounting suggestions, see example opposite.

When fixing the safety switch to a sliding door (A), ensure that when the door is opened (B) it is not easily accessible, helping prevent the system being overridden.

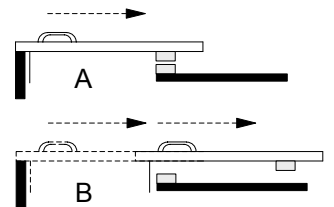
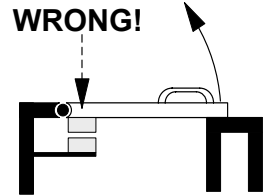
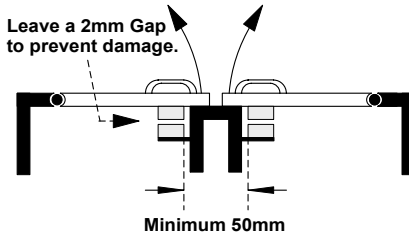

Contacts & Connections

MS3-21 (ac or dc)

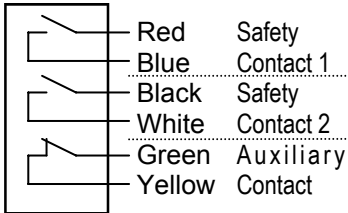

MS3-20 (ac or dc)

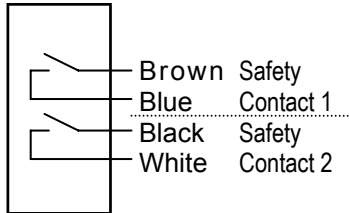

MS3-11 (ac or dc)

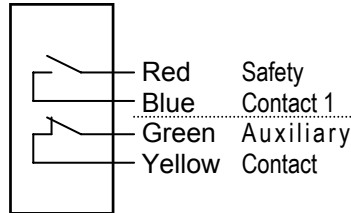

MS3-10 (ac or dc)

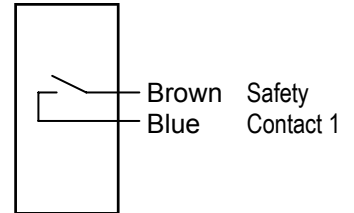

MS2-11 (ac or dc)

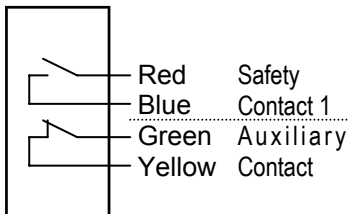

MS2-10 (ac or dc)

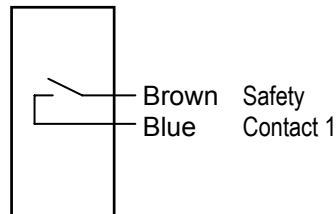

All Safety contacts should be fused externally

	Safety Contact External Fuse AC	Safety Contact External Fuse DC
MS3-21 / MS3-20 / MS3-11 / MS3-10	1.6 Amps quick blow	0.8 Amps Quick Blow
MS2-11 / MS2-10	1.6 Amps quick blow	0.8 Amps Quick Blow

Dimensions

MS2 RED ABS HOUSING

Dimensions in mm and [inches in brackets]

MS3 RED ABS HOUSING

Dimensions in mm and [inches in brackets]

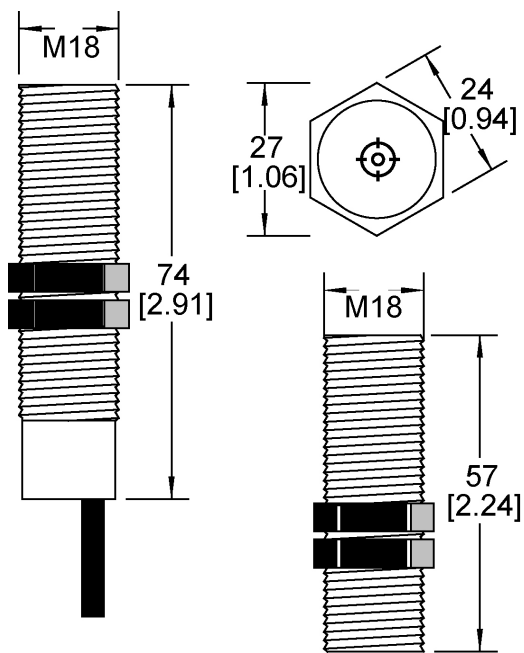

SWITCH

ACTUATOR

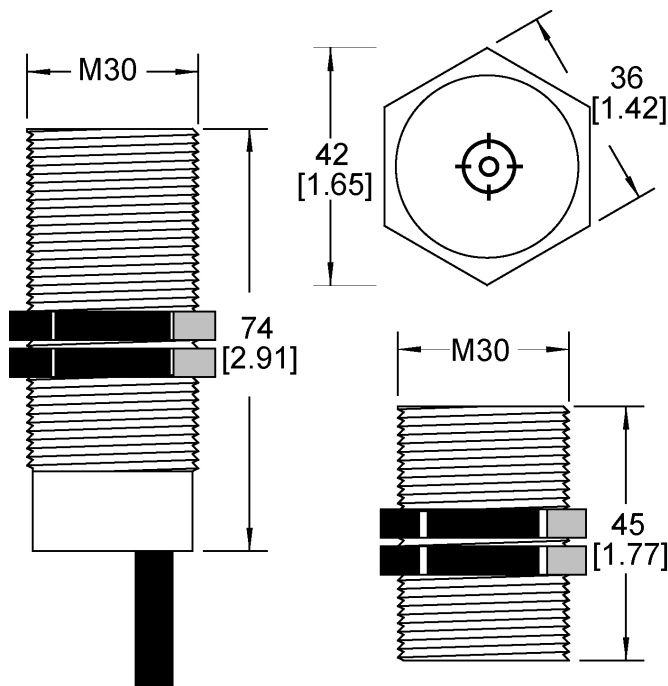

SWITCH

ACTUATOR

Technical Specifications

Type		AC	DC
Contact Arrangement	MS3-21 MS3-20 MS3-11 MS2-11 MS3-10 MS2-10	2 x N/O Safety & 1 x N/C Aux. 2 x N/O Safety 1 x N/O Safety & 1 x N/C Aux. 1 x N/O Safety	2 x N/O Safety & 1 x N/C Aux. 2 x N/O Safety 1 x N/O Safety & 1 x N/C Aux. 1 x N/O Safety
Safety Contact Rating		230Vac/2Amps	30Vdc / 1Amp Inductive/Resistive
Safety Contact Operating Distance	MS2 MS3	10mm ON / 30mm OFF 10mm ON / 35mm OFF	10mm ON / 30mm OFF 10mm ON / 35mm OFF
Safety Contact Close/Drop/Bounce		3ms / 2.1ms / 0.7ms	3ms / 2.1ms / 0.7ms
Auxiliary Contact Rating		15W / 10VA	15W / 10VA
Auxiliary Contact Operating Distance	MS2 MS3	7mm OFF / 14mm ON 7mm OFF / 20mm ON	7mm OFF / 14mm ON 7mm OFF / 20mm ON
Auxiliary Contact Close/Drop/Bounce		0.5ms / 0.3ms / 0.7ms	0.5ms / 0.3ms / 0.7ms
Internal Fuse		2Amp Fast Acting	1Amp Fast Acting
External Fuse (Customer Supplied)		1.6 Amps Fast Acting	0.8 Amp Fast Acting
IP Rating		IP67	IP67
Vibration / Shock		50—100Hz / 10g	50—100Hz / 10g
Operating Temperature		-10 to +55C	-10 to +55C
Mounting & Fixture		Target to Target	Target to Target
Connection		Pre-wired cable	Pre-wired cable
Construction		Red ABS Resin Filled	Red ABS Resin Filled

Part Numbers

PART NUMBER	DESCRIPTION	STOCK CODE
MS2 DC		
MS2-10-DC-03M	1 x N/O, DC, ABS, M18 Barrel Safety Switch & Actuator, 3 metre Pre-wired	351.050
MS2-11-DC-03M	1 x N/O + 1 x N/C, DC, ABS, M18 Barrel Safety Switch & Actuator, 3 metre Pre-wired	351.051
MS2 AC		
MS2-10-AC-03M	1 x N/O, AC, ABS, M18 Barrel Safety Switch & Actuator, 3 metre Pre-wired	351.000
MS2-11-AC-03M	1 x N/O + 1 x N/C, AC, ABS, M18 Barrel Safety Switch & Actuator, 3 metre Pre-wired	351.001
MS3 DC		
MS3-10-DC-03M	1 x N/O, DC, ABS, M30 Barrel Safety Switch & Actuator, 3 metre Pre-wired	352.050
MS3-11-DC-03M	1 x N/O + 1 x N/C, DC, ABS, M30 Barrel Safety Switch & Actuator, 3 metre Pre-wired	352.051
MS3-20-DC-03M	2 x N/O, DC, ABS, M30 Barrel Safety Switch & Actuator, 3 metre Pre-wired	352.052
MS3-21-DC-03M	2 x N/O + 1 x N/C, DC, ABS, M30 Barrel Safety Switch & Actuator, 3 metre Pre-wired	352.053
MS3 AC		
MS3-10-AC-03M	1 x N/O, AC, ABS, M30 Barrel Safety Switch & Actuator, 3 metre Pre-wired	352.000
MS3-11-AC-03M	1 x N/O + 1 x N/C, AC, ABS, M30 Barrel Safety Switch & Actuator, 3 metre Pre-wired	352.001
MS3-20-AC-03M	2 x N/O, AC, ABS, M30 Barrel Safety Switch & Actuator, 3 metre Pre-wired	352.002
MS3-21-AC-03M	2 x N/O + 1 x N/C, AC, ABS, M30 Barrel Safety Switch & Actuator, 3 metre Pre-wired	352.003
LONGER CABLES AVAILABLE		

Specification Changes

In the interest of product development, specifications are subject to change without notice.

It is the responsibility of the user to ensure compliance with any acts or by-laws that may be in force.

All information regarding Mechan Equipment is believed to be accurate at the time of printing. Responsibility cannot be accepted for errors or omissions.



MECHAN CONTROLS PLC
14/16 Seddon Place
Stanley Industrial Estate
Skelmersdale
Lancashire WN8 8EB

UNITED KINGDOM
Tel: +44 (0)1695 722264
Fax: +44 (0)1695 729664

Document Number: 351-400 Issue 8

Copyright Mechan Controls PLC 2007

Email: sales@mechancontrols.co.uk
Web Site: www.mechancontrols.co.uk



SCATTERGOOD & JOHNSON LTD

ELECTRICAL ENGINEERING & FLUID CONTROL DISTRIBUTORS

Est.1899

At Scattergood & Johnson Ltd, we pride ourselves on being a technical distributor to specialist industries.

Working with a range of quality product suppliers across a number of specialist markets, we are not your average 'box shifter' - we are your technical and supply chain partner.

We fully support every product we sell - for free! Our internal team and external sales engineers can answer any product or application question, no matter the complexity.

Backing up this technical ability is a range of 50,000+ products available from stock for nationwide next day delivery (same day if required!), or you can collect what you need from any of our trade counters around the UK.

Select your specialist interest below to learn more about how we can help.



Online, In Branch and On the Road - Scattergood & Johnson Ltd, there when you need us.

www.scatts.co.uk