

UniOP

Universal Operator Panels

Installation Guide



MANUUNIOP22- v.1.08 - 07.2004

UniOP™
Universal Operator Panel
Installation Guide
Document code MANUUNIOP22
Version 1.08
Date 13.07.2004

The contents of this manual have been checked for correctness and conformance to the described equipment, Nevertheless it is not possible to guarantee the absence of possible discrepancies. The contents of the manual are checked on a regular basis and any necessary corrections are introduced in successive versions.

Information in this document is subject to change without notice.

No part of this manual may be reproduced or transmitted in any form or by any means, electronic or mechanical, for any purpose, without the prior written permission of SITEK S.p.A

Windows is a registered trademark of Microsoft Corporation.

Copyright © 2001 SITEK S.p.A. All rights reserved.

SITEK S.p.A. - San Giovanni Lupatoto VR, Italy.
Printed in Italy.

Installation Guide

Contents

Introduction.....	1
Product Identification	3
Technical Specifications	3
Installation	26
Physical Dimensions.....	26
Connections	44
Power Supply and Grounding.....	57
PLC Port	58
PC/Printer Port.....	59
AUX Port.....	61
Models without the PC/Printer Port.....	63
External Keyboard Port	63
Battery Replacement.....	64
Removing the Legends	65
Dedicated LED's	66
Usage and Safety Guidelines	67
Installation Environment	67
Installation Procedures.....	70
Handling the Memory Cards.....	71
Getting Started	72
Command Summary	73
Troubleshooting	77
Touchscreen Calibration	77

UniOP

ii

Introduction

This Installation Guide describes the main features of the UniOP operator panels. The Guide refers to the following models:

BKDC-16	Operator interface with color display
BKDC-16T	Operator interface with touch and color display
BKDC-46	Operator interface with color display
BKDL-16	Operator interface with EL display
BKDL-16T	Operator interface with touch and EL display
BKDR-16	Operator interface with LCD display
BKDR-16T	Operator interface with touch and LCD display
BKDR-46	Operator interface with LCD display
CP01F-02	Operator interface with VFD display
CP01R-04	Operator interface with LCD display
CP02F-02	Operator interface with VFD display
CP02R-04	Operator interface with LCD display
CP04F-04	Operator interface with VFD display
CP05R-04	Operator interface with LCD display
CP10G-04	Operator interface with LCD display
CP11G-04	Operator interface with LCD display
CP12G-04	Operator interface with LCD display
CP13G-04	Operator interface with LCD display
ECT-16	Operator interface with touch and color display
ECT-VGA	Operator interface with touch and VGA color display
EF-02	Operator interface with VFD display
EF-04	Operator interface with VFD display
EL-16N	Operator interface with EL display
ELT-16	Operator interface with touch and EL display
ELT-VGA	Operator interface with touch and VGA display
EL-VGA	Operator interface with VGA display
ePAD30	Operator interface with TFT display
ePAD30T	Operator interface with touch and TFT display
ePAD31	Operator interface with LCD display
ePAD31T	Operator interface with touch and LCD display
ePAD32	Operator interface with VGA display
ePAD32T	Operator interface with touch and VGA display
ePAD33	Operator interface with TFT display
ePAD33T	Operator interface with touch and TFT display
ER-04	Operator interface with LCD display
ER-16	Operator interface with LCD display
ER-16TA	Operator interface with touch and LCD display
ER-25	Operator interface with LCD display

UniOP

ER-25T	Operator interface with touch and LCD display
ERT-16	Operator interface with touch and LCD display
ERT-VGA	Operator interface with touch and VGA display
ER-VGA	Operator interface with VGA display
eTOP05	Operator interface with LCD 5"7 display
eTOP10	Operator interface with TFT 5"7 display
eTOP11	Operator interface with LCD 5"7 display
eTOP12	Operator interface with LCD B/W 5"7 display
eTOP30	Operator interface with TFT 10"4 display
eTOP31	Operator interface with LCD 10"4 display
eTOP32	Operator interface with VGA B/W 9"4 display
eTOP33	Operator interface with TFT 10"4 display
eTOP40	Operator interface with TFT 12"1 display
eTOP50	Operator interface with XGA TFT 15" display
ETT-VGA	Operator interface with touch and TFT color display
MD00G-04	Operator interface with LCD display
MD00R-02	Low-cost operator interface with LCD display
MD00R-04	Low-cost operator interface with LCD display
MD01R-02	Low-cost operator interface with LCD display
MD02F-02	Low-cost operator interface with VFD display
MD02G-04	Low-cost operator interface with LCD display
MD02R-04	Low-cost operator interface with LCD display
MD03R-02	Low-cost operator interface with LCD display
MD03R-04	Low-cost operator interface with LCD display
MKDC-VGA	Operator interface with VGA color display
MKDC-VGA-T	Operator interface with touch and VGA color display
MKDF-02	Operator interface with VFD display
MKDF-04	Operator interface with VFD display
MKDG-05	Operator interface with LCD display
MKDG-06	Operator interface with LCD display
MKDG-07	Operator interface with LCD display
MKDL-16N	Operator interface with EL display
MKDL-VGA	Operator interface with VGA display
MKDR-04	Operator interface with LCD display
MKDR-05	Operator interface with LCD display
MKDR-16	Operator interface with LCD display
MKDR-16TA	Operator interface with touch and LCD display
MKDR-25	Operator interface with LCD display
MKDR-VGA	Operator interface with VGA display
MKDR-VGA-T	Operator interface with touch and VGA display
MKDT-VGA	Operator interface with TFT color display
MKDT-VGA-T	Operator interface with touch and TFT color display

TP01C-16	Operator interface with color display
TP01R-16	Operator interface with LCD display

The products have been designed for installation in an industrial environ in compliance with the regulations:

Emitted interference	EN 61000-6-4
Noise Immunity	EN 61000-6-2

In compliance with the above regulations the products are CE marked.

Product Identification

The product may be identified through a plate attached to the rear cover. You will have to know the type of unit you are using for correct usage of the information contained in the guide.

An example of this plate is shown in the figure below:



eTOP10-0050	product model name
11/01	month/year of production
13435 35508	serial number
H/W V	hardware version of the product
S/W V	software version of the product

Technical Specifications

Power supply voltage	DC 18 - 30 V
Power consumption	(1)

UniOP

Back-up battery ⁽¹⁾	3 V 270mA Lithium, not rechargeable, life about 1 year, user replaceable, model: CR2430. Change with same battery or equivalent with the work temperature of UniOP.
Fuse	2 A T user replaceable (except the models CP10G-04, CP11G-04, CP12G-04, CP13G-04, MKDG-06, MKDG-07, MD00G-04, MD00R-02/04, ePAD30, ePAD30T, ePAD31, ePAD31T, ePAD32, ePAD32T, ePAD33, ePAD33T and eTOP05/10/11/12 eTOP30/31/32/33/40/50 that are equipped with an overcurrent protection device)

Environmental conditions

Operating temperature	0 ÷ +50°C, with the exception of the model indicated on note ⁽²⁾	EN 60068-2-14
Storage temperature	-20 ÷ +70°C	EN 60068-2-14
Operating and storage humidity	5 ÷ 85 % RH not-condensing	EN 60068-2-30
Vibrations	10 ÷ 57 Hz, 0,075 mm peak 57 ÷ 150 Hz, 1 G	EN 60068-2-6
Shock	50 G, 11 ms, 3 pulses per axis	EN 60068-2-27
Protection class	IP65 front panel ⁽³⁾	EN 60529
Keyboard reliability	> 3 million operations	
Touch screen technology	Resistive	
Touch screen reliability	> 1 million operations	

Electromagnetic Compatibility (EMC)

Emitted interference	Class A	EN 55011
Immunity to radiated radiofrequency electromagnetic field	80 MHz ÷ 1 GHz, 10 V/m 900 MHz, 10V/m	EN 61000-4-3 ENV 50204
Immunity to conducted disturbances inducted by radiofrequency field	0.15 ÷ 80 MHz, 10 V	EN 61000-4-6
Fast transient	2 KV power supply 1 KV signal lines	EN 61000-4-4
Electrostatic discharge	8 KV in air	EN 61000-4-2
PC/Printer Port ⁽¹⁾	RS-232connector D-sub 15 pin female 300 - 38400 baud	
PLC Port	RS-232, RS-422, RS-485, C.L. 20 mA (active), connector D-15 pin male 300 - 38400 ⁽¹⁾ baud	

AUX Port	connector D-9 pin female (functionality can be configured with an optional communication module)
User memory	(1)
Recipe memory (1)	16 KB / 32 KB RAM with back-up battery
Hardware clock (1)	Clock/Calendar with back-up battery
Alarms (1)	256/1024
Historical event list (1)	last 256/1024 events with back-up battery
Programming software	Designer version 6

Notes:

- (1) feature depends on the panel models; see Table 1.
- (2) for models with “A6” suffix range 0 ÷ +60°C ,
for models with “A7” suffix range -20 ÷ +60°C
for eTOP and ePAD range 0 ÷ +45°C
- (3) all the installation instructions listed in the chapter ‘Installation Environment’ must be followed in detail.

UniOP

Model	BKDC-16	BKDC-16T	BKDC-46
Display	16x40 STN COLOR	16x40 STN COLOR	16x40 STN COLOR
Backlight	CCFL	CCFL	CCFL
Graphics	320x240	320x240	320x240
Display dimensions (mm)	121x91	121x91	121x91
Diagonal (inches)	5.6"	5.6"	5.6"
Character height (mm)	-	-	-
User memory	512KB	512KB	8MB
User memory expansion	up to 1MB	up to 1MB	-
Function keys	14	14	33
System keys	23	23	24
Touch screen	-	YES	-
User LED's	11	11	24
System LED's	4	4	5
PC/Printer Port	YES	YES	YES
PLC Port	YES	YES	YES
AUX Port ⁽¹⁾	YES	YES	YES
External keyboard Port	YES	YES	-
Programming speed	9600-38400	9600-38400	9600-38400
Battery	YES	YES	YES
Recipe memory	32KB	32KB	32KB
Alarms	1024	1024	1024
Events list	1024	1024	1024
Hardware clock	YES	YES	YES
Downloadable characters	256	256	256
Screen saver	YES	YES	-YES
Buzzer	-	-	-
Max current consumption on 24VDC (mA)	500	500	600
Suffix 45: dimensions WxHxD (mm) ⁽²⁾	216x168x82	216x168x82	275x220x80
Suffix 50: dimensions WxHxD (mm) ⁽³⁾	-	-	-
Max panel thickness (mm)	8	8	5
Weight (Kg)	1.4	1.4	1.9

Table 1 - UniOP Technical Data

BKDL-16	BKDL-16T	BKDR-16	BKDR-16T	BKDR-46	CP01F-02
16x40 EL	16x40 EL	16x40 LCD	16x40 LCD	16x40 LCD	2x20 VFD
CCFL	CCFL	CCFL	CCFL	CCFL	LED
320x240	320x240	320x240	320x240	320x240	-
121x91	121x91	121x91	121x91	121x91	-
5.6"	5.6"	5.6"	5.6"	5.6"	-
-	-	-	-	-	5
512KB	512KB	512KB	512KB	8MB	512KB
up to 1MB	up to 1MB	up to 1MB	up to 1MB	-	up to 1MB
14	14	14	14	33	5
23	23	23	23	24	19
-	YES	-	YES	-	-
11	11	11	11	24	5
4	4	4	4	5	1
YES	YES	YES	YES	YES	YES
YES	YES	YES	YES	YES	YES
YES	YES	YES	YES	YES	YES
YES	YES	YES	YES	-	-
9600-38400	9600-38400	9600-38400	9600-38400	9600-38400	9600-38400
YES	YES	YES	YES	YES	YES
32KB	32KB	32KB	32KB	32KB	16KB
1024	1024	1024	1024	1024	1024
1024	1024	1024	1024	1024	256
YES	YES	YES	YES	YES	YES
256	256	256	256	256	-
-	-	YES	YES	YES	-
-	-	-	-	-	-
800	800	500	500	600	300
216x168x82	216x168x82	216x168x82	216x168x82	275x220x80	138x186x82
-	-	-	-	-	-
8	8	8	8	5	8
1.4	1.4	1.4	1.4	1.9	1.1

Table 1 - UniOP Technical Data

UniOP

Model	CP01R-04	CP02F-02	CP02R-04
Display	4x20 LCD	2x20 VFD	4x20 LCD
Backlight	LED	LED	LED
Graphics	-	-	-
Display dimensions (mm)	-	-	-
Diagonal (inches)	-	-	-
Character height (mm)	5	5	5
User memory	512KB	512KB	512KB
User memory expansion	up to 1MB	up to 1MB	up to 1MB
Function keys	5	16	16
System keys	19	18	18
Touch screen	-	-	-
User LED's	5	16	16
System LED's	1	1	1
PC/Printer Port	YES	YES	YES
PLC Port	YES	YES	YES
AUX Port ⁽¹⁾	YES	YES	YES
External keyboard Port	-	-	-
Programming speed	9600-38400	9600-38400	9600-38400
Battery	YES	YES	YES
Recipe memory	16KB	16KB	16KB
Alarms	1024	1024	1024
Events list	256	256	256
Hardware clock	YES	YES	YES
Downloadable characters	8	-	8
Screen saver	-	-	-
Buzzer	-	-	-
Max current consumption on 24VDC (mA)	250	300	250
Suffix 45: dimensions WxHxD (mm) ⁽²⁾	138x186x82	138x186x82	138x186x82
Suffix 50: dimensions WxHxD (mm) ⁽³⁾	-	-	-
Max panel thickness (mm)	8	8	8
Weight (Kg)	1.1	1.1	1.1

Table 1 - UniOP Technical Data

CP04F-04	CP05R-04	CP10G-04	CP11G-04	CP12G-04	CP13G-04
4x20 VFD	4x20 LCD	4x20 LCD	4x20 LCD	4x20 LCD	4x20 LCD
LED	LED	LED	LED	LED	LED
-	-	120x32	120x32	120x32	120x32
-	-	70x21	70x21	70x21	70x21
-	-	2.8"	2.8"	2.8"	2.8"
5	5	-	-	-	-
512KB	512KB	512KB	512KB	512KB	512KB
up to 1MB	up to 1MB	up to 1MB	up to 1MB	up to 1MB	up to 1MB
10	5	12	12	23	23
19	19	23	23	24	24
-	-	-	-	-	-
10	5	13	13	32	32
2	1	4	4	5	5
YES	-	YES	-	YES	-
YES	YES	YES	YES	YES	YES
YES	YES	YES	YES	YES	YES
-	-	-	-	-	-
9600-38400	9600	9600-38400	9600	9600-38400	9600
YES	-	YES	-	YES	-
16KB	-	16KB	-	16KB	-
1024	256	1024	256	1024	256
256	-	256	-	256	-
YES	-	YES	-	YES	-
-	8	256	256	256	256
-	-	-	-	-	-
-	-	-	-	-	-
450	250	300	300	250	250
168x216x82	138x186x82	141x176x76	141x176x76	275x220x76	275x220x76
-	-	141x176x80	141x176x80	275x220x85	275x220x85
8	8	5	5	5	5
1.3	1.1	1.1	1.1	2	2

Table 1 - UniOP Technical Data

UniOP

Model	ECT-16	ECT-VGA	EF-02
Display	16x40 STN COLOR	30x80 STN COLOR	2x40 VFD
Backlight	CCFL	CCFL	CCFL
Graphics	320x240	640x480	-
Display dimensions (mm)	121x91	212x159	-
Diagonal (inches)	5.6"	10.4"	-
Character height (mm)	-	-	5
User memory	512KB	8MB	512KB
User memory expansion	up to 1MB		up to 1MB
Function keys	-	8	-
System keys	-	3	5
Touch screen	YES	YES	-
User LED's	-	8	-
System LED's	5	5	4
PC/Printer Port	YES	YES	YES
PLC Port	YES	YES	YES
AUX Port ⁽¹⁾	YES	YES	YES
External keyboard Port	YES	YES	YES
Programming speed	9600-38400	9600-38400	9600-38400
Battery	YES	YES	YES
Recipe memory	32KB	32KB	16KB
Alarms	1024	1024	1024
Events list	1024	1024	256
Hardware clock	YES	YES	YES
Downloadable characters	256	256	-
Screen saver	YES	YES	-
Buzzer	YES	-	-
Max current consumption on 24VDC (mA)	500	700	500
Suffix 45: dimensions WxHxD (mm) ⁽²⁾	216x168x82	311x220x89	311x111x89
Suffix 50: dimensions WxHxD (mm) ⁽³⁾	-	-	-
Max panel thickness (mm)	8	9	9
Weight (Kg)	1.4	2.7	1.7

Table 1 - UniOP Technical Data

EF-04	EL-16N	ELT-16	ELT-VGA	EL-VGA	ePAD30
4x40 VFD	16x40 EL	16x40 EL	30x80 EL	30x80	30x80 TFT
CCFL	CCFL	CCFL	CCFL	CCFL	CCFL
-	320x240	320x240	640x480	640x480	640X480
-	121x91	121x91	212x159	212x159	218X159
-	5.6"	5.6"	10.4"	10.4"	10.4"
5	-	-	-	-	-
512KB	512KB	512KB	8MB	8MB	8MB
up to 1MB	up to 1MB	up to 1MB	-	-	16MB
-	-	-	8	8	12
5	5	-	3	3	47
-	-	YES	YES	-	-
-	-	-	-	8	24
4	4	5	4	5	5
YES	YES	YES	YES	YES	YES
YES	YES	YES	YES	YES	YES
YES	YES	YES	YES	YES	YES
YES	YES	YES	YES	YES	-
9600-38400	9600-38400	9600-38400	9600-38400	9600-38400	9600-38400
YES	YES	YES	YES	YES	YES
16KB	32KB	32KB	32KB	32KB	32 KB
1024	1024	1024	1024	1024	1024
256	1024	1024	1024	1024	1024
YES	YES	YES	YES	YES	YES
-	256	256	256	256	256
-	-	-	-	-	YES
-	-	YES	-	-	YES
700	800	800	1300	1300	700
311x111x89	311x165x89	216x168x82	311x220x89	311x220x89	-
-	-	-	-	-	311x276x100
9	9	8	9	9	4
1.9	2.4	1.4	2.7	2.7	2.7

Table 1 - UniOP Technical Data

UniOP

Model	ePAD30T	ePAD31	ePAD31T
Display	30x80 TFT	30x80 STN COLOR	30x80 STN COLOR
Backlight	CCFL	CCFL	CCFL
Graphics	640X480	640X480	640X480
Display dimensions (mm)	218X159	218X159	218X159
Diagonal (inches)	10.4"	10.4"	10.4"
Character height (mm)	-	-	-
User memory	8MB	8MB	8MB
User memory expansion	16MB	16MB	16MB
Function keys	12	12	12
System keys	47	47	47
Touch screen	YES	-	YES
User LED's	24	24	24
System LED's	5	5	5
PC/Printer Port	YES	YES	YES
PLC Port	YES	YES	YES
AUX Port ⁽¹⁾	YES	YES	YES
External keyboard Port	-	-	-
Programing speed	9600-38400	9600-38400	9600-38400
Battery	YES	YES	YES
Recipe memory	32 KB	32 KB	32 KB
Alarms	1024	1024	1024
Events list	1024	1024	1024
Hardware clock	YES	YES	YES
Downloadable characters	256	256	256
Screen saver	YES	YES	YES
Buzzer	YES	YES	YES
Max current consumption on 24VDC (mA)	700	700	700
Suffix 45: diemnsions WxHxD (mm) ⁽²⁾	-	-	-
Suffix 50: diemnsions WxHxD (mm) ⁽³⁾	311x276x100	311x276x100	311x276x100
Max panel thickness (mm)	4	4	4
Weight (Kg)	2.7	2.7	2.7

Table 1 - UniOP Technical Data

ePAD32	ePAD32T	ePAD33	ePAD33T	ER-04	ER-16
30x80 LCD	30x80 LCD	30x80 TFT	30x80 TFT	4x40 LCD	16x40 LCD
CCFL	CCFL	CCFL	CCFL	CCFL	CCFL
640X400	640X400	640X480	640X480	-	320x240
218X159	218X159	218X159	218X159	-	121x91
10.4"	10.4"	10.4"	10.4"	-	5.6"
-	-	-	-	5	-
8MB	8MB	8MB	8MB	512KB	512KB
16MB	16MB	16MB	16MB		up to 1MB
12	12	12	12	-	-
47	47	47	47	5	5
-	YES	-	YES	-	-
24	24	24	24	-	-
5	5	5	5	4	4
YES	YES	YES	YES	YES	YES
YES	YES	YES	YES	YES	YES
YES	YES	YES	YES	YES	YES
-	-	-	-	YES	YES
9600-38400	9600-38400	9600-38400	9600-38400	9600-38400	9600-38400
YES	YES	YES	YES	YES	YES
32 KB	32 KB	32 KB	32 KB	16KB	32KB
1024	1024	1024	1024	1024	1024
1024	1024	1024	1024	256	1024
YES	YES	YES	YES	YES	YES
256	256	256	256	8	256
YES	YES	YES	YES	-	YES
YES	YES	YES	YES	-	-
700	700	700	700	400	500
-	-	-	-	311x111x89	311x165x89
311x276x100	311x276x100	311x276x100	311x276x100	-	-
4	4	4	4	9	9
2.7	2.7	2.7	2.7	1.7	2.4

Table 1 - UniOP Technical Data

UniOP

Model	ER-16TA	ER-25	ER-25T
Display	16x40 LCD	25x80 LCD	25x80 LCD
Backlight	CCFL	CCFL	CCFL
Graphics	320x240	640x400	640x400
Display dimensions (mm)	121x91	194x121	194x121
Diagonal (inches)	5.6"	9.6"	9.6"
Character height (mm)	-	-	-
User memory	512KB	512KB	512KB
User memory expansion	up to 1MB	Up to 1MB	up to 1MB
Function keys	-	-	-
System keys	5	5	5
Touch screen	YES	-	YES
User LED's	-	-	-
System LED's	4	4	4
PC/Printer Port	YES	YES	YES
PLC Port	YES	YES	YES
AUX Port ⁽¹⁾	YES	YES	YES
External keyboard Port	YES	YES	YES
Programming speed	9600-38400	9600-38400	9600-38400
Battery	YES	YES	YES
Recipe memory	32KB	32KB	32KB
Alarms	1024	1024	1024
Events list	1024	1024	1024
Hardware clock	YES	YES	YES
Downloadable characters	256	256	256
Screen saver	YES	YES	YES
Buzzer	-	-	-
Max current consumption on 24VDC (mA)	500	600	600
Suffix 45: dimensions WxHxD (mm) ⁽²⁾	311x165x89	311x220x89	311x220x89
Suffix 50: dimensions WxHxD (mm) ⁽³⁾	-	-	-
Max panel thickness (mm)	9	9	9
Weight (Kg)	2.4	2.7	2.7

Table 1 - UniOP Technical Data

ERT-16	ERT-VGA	ER-VGA	eTOP05	eTOP10	eTOP11
16x40 LCD	30x80 LCD	30x80 LCD	16X40 LCD	16X40 TFT	16X40 STN COLOR
CCFL	CCFL	CCFL	LED	CCFL	CCFL
320x240	640x480	640x480	320x240	320x240	320x240
121x91	194x146	194x146	121x91	121x91	121x91
5.6"	9.6"	9.6"	5.7"	5.7"	5.7"
-	-	-	-	-	-
512KB	2MB	2MB	8MB	8MB	8MB
up to 1MB	-	-	-	-	-
-	8	8	-	-	-
-	3	3	-	-	-
YES	YES	-	YES	YES	YES
-	8	8	-	-	-
5	5	5	5	5	5
YES	YES	YES	YES	YES	YES
YES	YES	YES	YES	YES	YES
YES	YES	YES	YES	YES	YES
YES	YES	YES	-	-	-
9600-38400	9600-38400	9600-38400	9600-38400	9600-38400	9600-38400
YES	YES	YES	YES	YES	YES
32KB	32KB	32KB	32KB	32KB	32KB
1024	1024	1024	1024	1024	1024
1024	1024	1024	1024	1024	1024
YES	YES	YES	YES	YES	YES
256	256	256	256	256	256
YES	YES	YES	YES	YES	YES
YES	-	-	YES	YES	YES
500	600	600	600	600	600
216x168x82	311x220x89	311x220x89	-	-	-
-	-	-	187x147x71	187x147x95	187x147x95
8	9	9	4	4	4
1.4	2.7	2.7	1.4	1.4	1.4

Table 1 - UniOP Technical Data

UniOP

Model	eTOP12	eTOP30	eTOP31
Display	16X40 LCD	30X80 TFT	30X80 STN COLOR
Backlight	CCFL	CCFL	CCFL
Graphics	320X240	640X480	640x480
Display dimensions (mm)	121X91	218X159	218x159
Diagonal (inches)	5.7"	10.4"	10.4"
Character height (mm)	-	-	-
User memory	8MB	8MB	8MB
User memory expansion	-	-	-
Function keys	-	-	-
System keys	-	-	-
Touch screen	YES	YES	YES
User LED's	-	-	-
System LED's	5	5	5
PC/Printer Port	YES	YES	YES
PLC Port	YES	YES	YES
AUX Port ⁽¹⁾	YES	YES	YES
Esternal keyboard Port	-	-	-
Programming speed	9600-38400	9600-38400	9600-38400
Battery	YES	YES	YES
Recipe memory	32 KB	32 KB	32KB
Alarms	1024	1024	1024
Events list	1024	1024	1024
Hardware clock	YES	YES	YES
Downloadable characters	256	256	256
Screen saver	YES	YES	YES
Buzzer	YES	YES	YES
Max current consumption on 24VDC	600	700	700
Suffix 45: dimensions WxHxD (mm) ⁽²⁾	-	-	-
Suffix 50: dimensions WxHxD (mm) ⁽³⁾	187x147x95	287x232x95	287x232x95
Max panel thickness (mm)	4	4	4
Weight (Kg)	1.4	2.25	2.25

Table 1 - UniOP Technical Data

eTOP32	eTOP33	eTOP40	eTOP50	ETT-VGA	MD00G-04
30X80 LCD	30X80 TFT	40X100 TFT	48X128 TFT	30x80 TFT	4x20 LCD
CCFL	CCFL	CCFL	CCFL	CCFL	LED
640X480	640X480	800X600	1024X768	640x480	120x32
218x159	218X159	246x184	304X228	194x146	70x21
10.4"	10.4"	12.1"	15"	9.6"	2.8"
-	-	-	-	-	-
8MB	8MB	8MB	8MB	512KB	512KB
-	-	-	-	-	-
-	-	-	-	8	4
-	-	-	-	3	7
YES	YES	YES	YES	YES	-
-	-	-	-	8	5
5	5	5	5	6	4
YES	YES	YES	YES	YES	-
YES	YES	YES	YES	YES	YES
YES	YES	YES	YES	YES	YES
-	-	-	-	YES	-
9600-38400	9600-38400	9600-38400	9600-38400	9600-38400	9600
YES	YES	YES	YES	YES	-
32KB	32 KB	32 KB	32 KB	32KB	-
1024	1024	1024	1024	1024	256
1024	1024	1024	1024	1024	-
YES	YES	YES	YES	YES	-
256	256	256	256	256	256
YES	YES	YES	YES	YES	-
YES	YES	YES	YES	-	-
700	700	800	1200	700	250
-	-	-	-	311x220x89	149x109x53
287x232x95	287x232x95	337x267x95	392x307x104	-	-
4	4	4	4	9	5
2.25	2.25	2.85	3.85	2.7	1

Table 1 - UniOP Technical Data

UniOP

Model	MD00R-02	MD00R-04	MD01R-02
Display	2x20 LCD	4x20 LCD	2x20 LCD
Backlight	LED	LED	LED
Graphics	-	-	-
Display dimensions (mm)	-	-	-
Diagonal (inches)	-	-	-
Character height (mm)	6	5	6
User memory	512KB	512KB	512KB
User memory expansion	-	-	-
Function keys	4	4	4
System keys	7	7	7
Touch screen	-	-	-
User LED's	5	5	4
System LED's	4	4	2
PC/Printer Port	-	-	-
PLC Port	YES	YES	YES
AUX Port ⁽¹⁾	YES	YES	YES
Esternal keyboard Port	-	-	-
Programming speed	9600	9600	9600
Battery	-	-	-
Recipe memory	-	-	-
Alarms	256	256	256
Events list	-	-	-
Hardware clock	-	-	-
Downloadable characters	8	8	8
Screen saver	-	-	-
Buzzer	-	-	-
Max current consumption on 24VDC	250	250	250
Suffix 45: dimensions WxHxD (mm) ⁽²⁾	149x109x53	149x109x53	195x98x82
Suffix 50: dimensions WxHxD (mm) ⁽³⁾	-	-	195x98x90
Max panel thickness (mm)	5	5	8
Weight (Kg)	0.9	0.9	0.9

Table 1 - UniOP Technical Data

MD02F-02	MD02G-04	MD02R-04	MD03R-02	MD03R-04	MKDC-VGA
2x20 VFD	4x20 LCD	4x20 LCD	2x20 LCD	4x20 LCD	30x80 STN COLOR
CCFL	LED	LED	LED	LED	CCFL
-	120x32	-	-	-	640x480
-	70x21	-	-	-	212x159
-	2.8"	-	-	-	10.4"
5	-	5	6	5	-
512KB	512KB	512KB	512KB	512KB	8MB
-	-	-	-	-	-
9	9	9	9	9	26
10	10	10	10	10	25
-	-	-	-	-	-
9	9	9	9	9	26
2	2	2	2	2	4
YES	YES	YES	-	-	YES
YES	YES	YES	YES	YES	YES
YES	YES	YES	YES	YES	YES
-	-	-	-	-	YES
9600-38400	9600-38400	9600-38400	9600	9600	9600-38400
YES	YES	YES	-	-	YES
16KB	16KB	16KB	-	-	32KB
1024	1024	1024	256	256	1024
256	256	256	-	-	1024
YES	YES	YES	-	-	YES
-	8	8	8	8	256
-	-	-	-	-	YES
-	-	-	-	-	-
300	250	250	250	250	700
195x98x82	195x98x82	195x98x82	195x98x82	195x98x82	311x276x89
-	-	195x98x90	195x98x90	195x98x90	-
8	8	8	8	8	9
0.9	0.9	0.9	0.9	0.9	3.5

Table 1 - UniOP Technical Data

UniOP

Model	MKDC-VGA-T	MKDF-02	MKDF-04
Display	30x80 STN COLOR	2x40 VFD	4x40 VFD
Backlight	CCFL	LED	LED
Graphics	640x480	-	-
Display dimensions (mm)	212x159	-	-
Diagonal (inches)	10.4"	-	-
Character height (mm)	-	5	5
User memory	8MB	512KB	512KB
User memory expansion	-	1024KB	1024KB
Function keys	26	16	16
System keys	25	29	29
Touch screen	YES	-	-
User LED's	26	24	24
System LED's	4	5	5
PC/Printer Port	YES	YES	YES
PLC Port	YES	YES	YES
AUX Port ⁽¹⁾	YES	YES	YES
External keyboard Port	YES	YES	YES
Programming speed	9600-38400	9600-38400	9600-38400
Battery	YES	YES	YES
Recipe memory	32KB	16KB	16KB
Alarms	1024	1024	1024
Events list	1024	256	256
Hardware clock	YES	YES	YES
Downloadable characters	256	-	-
Screen saver	YES	-	-
Buzzer	-	-	-
Max current consumption on 24VDC (mA)	700	500	700
Suffix 45: dimensions WxHxD (mm) ⁽²⁾	311x276x89	311x165x89	311x165x89
Suffix 50: dimensions WxHxD (mm) ⁽³⁾	-	-	-
Max panel thickness (mm)	9	9	9
Weight (Kg)	3.5	1.9	1.9

Table 1 - UniOP Technical Data

MKDG-05	MKDG-06	MKDG-07	MKDL-16N	MKDL-VGA	MKDR-04
8x40 LCD	8x40 LCD	8x40 LCD	16x40 EL	30x80	4x40 LCD
CCFL	CCFL	CCFL	CCFL	CCFL	LED
240x64	240x64	240x64	320x240	640x480	-
127x34	127x34	127x34	121x91	212x159	-
5.2"	5.2"	5.2"	5.6"	10.4"	-
5	-	-	-	-	5
512KB	512KB	512KB	512KB	8MB	512KB
1024KB	1024KB	up to 640 KB	up to 1MB	-	up to 1MB
20	23	23	16	26	16
18	24	24	19	24	29
-	-	-	-	-	-
26	24	32	24	26	24
4	5	5	5	5	5
YES	YES	YES	YES	YES	YES
YES	YES	YES	YES	YES	YES
YES	YES	YES	YES	YES	YES
-	-	-	YES	YES	YES
9600-38400	9600-38400	9600-38400	9600-38400	9600-38400	9600-38400
YES	YES	YES	YES	YES	YES
16KB	16KB	16KB	32KB	32KB	16KB
1024	1024	1024	1024	1024	1024
256	256	256	1024	1024	256
YES	YES	YES	YES	YES	YES
-	256	256	256	256	8
-	-	-	-	-	-
-	-	-	-	-	-
400	400	400	800	1300	400
311x111x89	220x176x73	275x220x76	311x220x89	311x276x76	311x165x89
-	220x176x85	275x220x85	-	-	-
9	5	5	9	9	9
1.9	1.2	2	2.5	3.5	1.9

Table 1 - UniOP Technical Data

UniOP

Model	MKDR-05	MKDR-16	MKDR-16TA
Display	4x40 LCD	16x40 LCD	16x40 LCD
Backlight	LED	CCFL	CCFL
Graphics	-	320x240	320x240
Display dimensions (mm)	-	121x91	121x91
Diagonal (inches)	-	5.6"	5.6"
Character height (mm)	5	-	-
User memory	512KB	512KB	512KB
User memory expansion	up to 1MB	Up to 1MB	up to 1MB
Function keys	20	16	16
System keys	18	19	19
Touch screen	-	-	YES
User LED's	26	24	24
System LED's	4	5	5
PC/Printer Port	YES	YES	YES
PLC Port	YES	YES	YES
AUX Port ⁽¹⁾	YES	YES	YES
External keyboard Port	YES	YES	YES
Programming speed	9600-38400	9600-38400	9600-38400
Battery	YES	YES	YES
Recipe memory	16KB	32KB	32KB
Alarms	1024	1024	1024
Events list	256	1024	1024
Hardware clock	YES	YES	YES
Downloadable characters	8	256	256
Screen saver	-	YES	YES
Buzzer	-	-	-
Max current consumption on 24VDC (mA)	350	500	500
Suffix 45: dimensions WxHxD (mm) ⁽²⁾	311x111x89	311x220x89	311x220x89
Suffix 50: dimensions WxHxD (mm) ⁽³⁾	-	-	-
Max panel thickness (mm)	9	9	9
Weight (Kg)	1.8	2.5	2.5

Table 1 - UniOP Technical Data

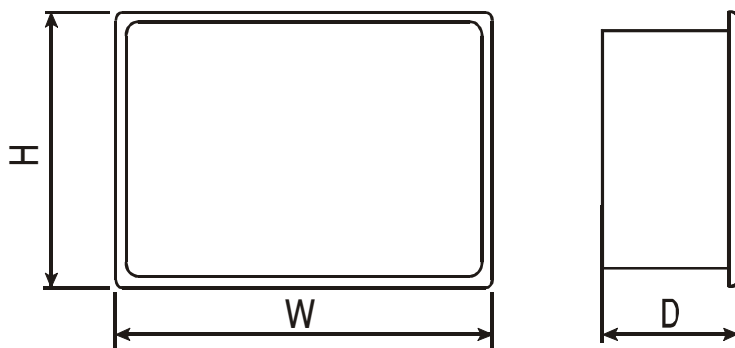
MKDR-25	MKDR-VGA	MKDR-VGA-T	MKDT-VGA	MKDT-VGA-T	TP01C-16
25x80 LCD	30x80	30x80	30x80	30x80	16x40 STN COLOR
CCFL	CCFL	CCFL	CCFL	CCFL	CCFL
640x400	640x480	640x480	640x480	640x480	320x240
194x121	194x146	194x146	212x159	212x159	121x91
9.6"	9.6"	9.6"	10.4"	10.4"	5.6"
-	-	-	-	-	-
512KB	8MB	8MB	8MB	8MB	512KB
up to 1MB	-	-	-	-	up to 1MB
26	26	26	26	26	30
24	24	24	24	24	25
-	-	YES	-	YES	-
26	26	26	26	26	32
4	5	5	5	5	4
YES	YES	YES	YES	YES	YES
YES	YES	YES	YES	YES	YES
YES	YES	YES	YES	YES	YES
YES	YES	YES	YES	YES	YES
9600-38400	9600-38400	9600-38400	9600-38400	9600-38400	9600-38400
YES	YES	YES	YES	YES	YES
32KB	32KB	32KB	32KB	32KB	32KB
1024	1024	1024	1024	1024	1024
1024	1024	1024	1024	1024	1024
YES	YES	YES	YES	YES	YES
256	256	256	256	256	256
YES	YES	YES	YES	YES	YES
-	-	-	-	-	-
600	600	600	700	700	500
311x276x89	311x276x89	311x276x89	311x276x89	311x276x89	220x311x89
-	-	-	-	-	-
9	9	9	9	9	9
3.5	3.5	3.5	3.5	3.5	2.5

Table 1 - UniOP Technical Data

Model	TP01R-16
Display	16x40 LCD
Backlight	CCFL
Graphics	320x240
Display dimensions (mm)	121x91
Diagonal (inches)	5.6"
Character height (mm)	-
User memory	512KB
User memory expansion	up to 1MB
Function keys	30
System keys	25
Touch screen	-
User LED's	32
System LED's	4
PC/Printer Port	YES
PLC Port	YES
AUX Port ⁽¹⁾	YES
Esternal keyboard Port	YES
Programing speed	9600-38400
Battery	YES
Recipe memory	32KB
Alarms	1024
Events list	1024
Hardware clock	YES
Downloadable characters	256
Screen saver	YES
Buzzer	-
Max current consumption on 24VDC (mA)	500
Suffix 45: dimensions WxHxD (mm) ⁽²⁾	220x311x89
Suffix 50: dimensions WxHxD (mm) ⁽³⁾	-
Max panel thickness (mm)	9
Weight (Kg)	2.5

Table 1 - UniOP Technical Data

Notes :



- (1) With optional module.
- (2) Suffix 45: for operator panel which have suffix A6, A7, 45.
- (3) Suffix 50: for operator panel which have suffix 50.

Installation

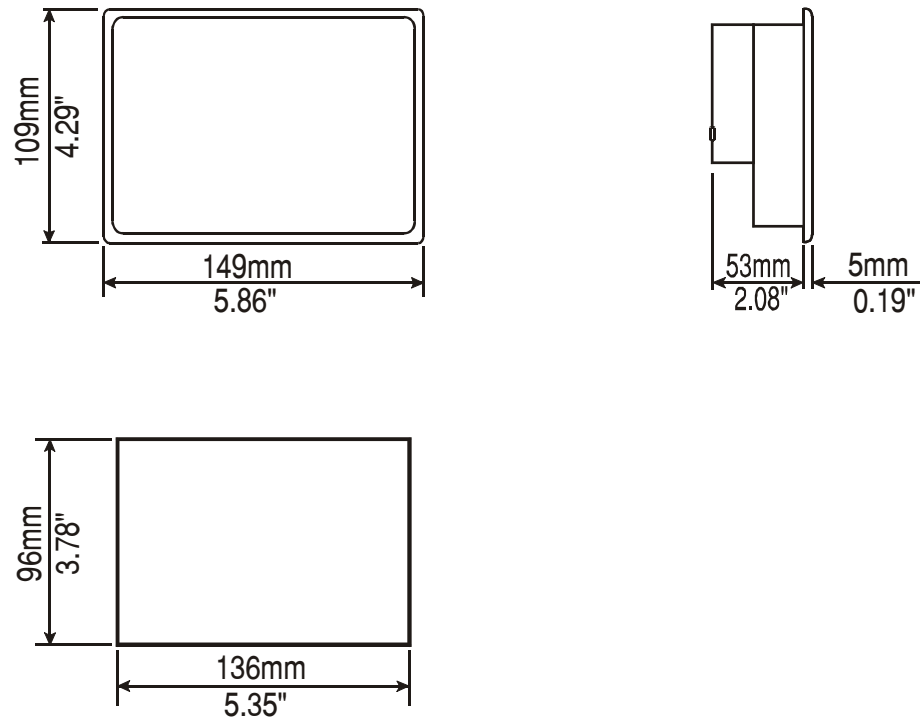
UniOP panels are designed to be mounted on the front of some type of enclosure. The bezel height, bezel width and the cut-out dimensions for each panel type are given in the following pages.

Note: remove the red BATTERY PROTECTION strip before installation

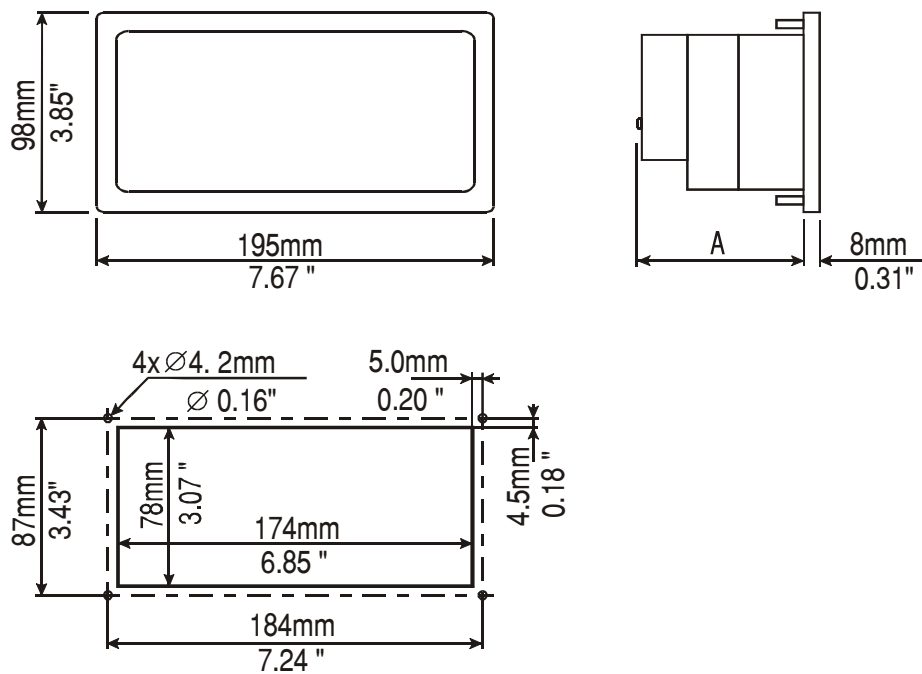
Physical Dimensions

All measurements are given in mm, with tolerance ± 0.5 .

MD00G-04, MD00R-02, MD00R-04



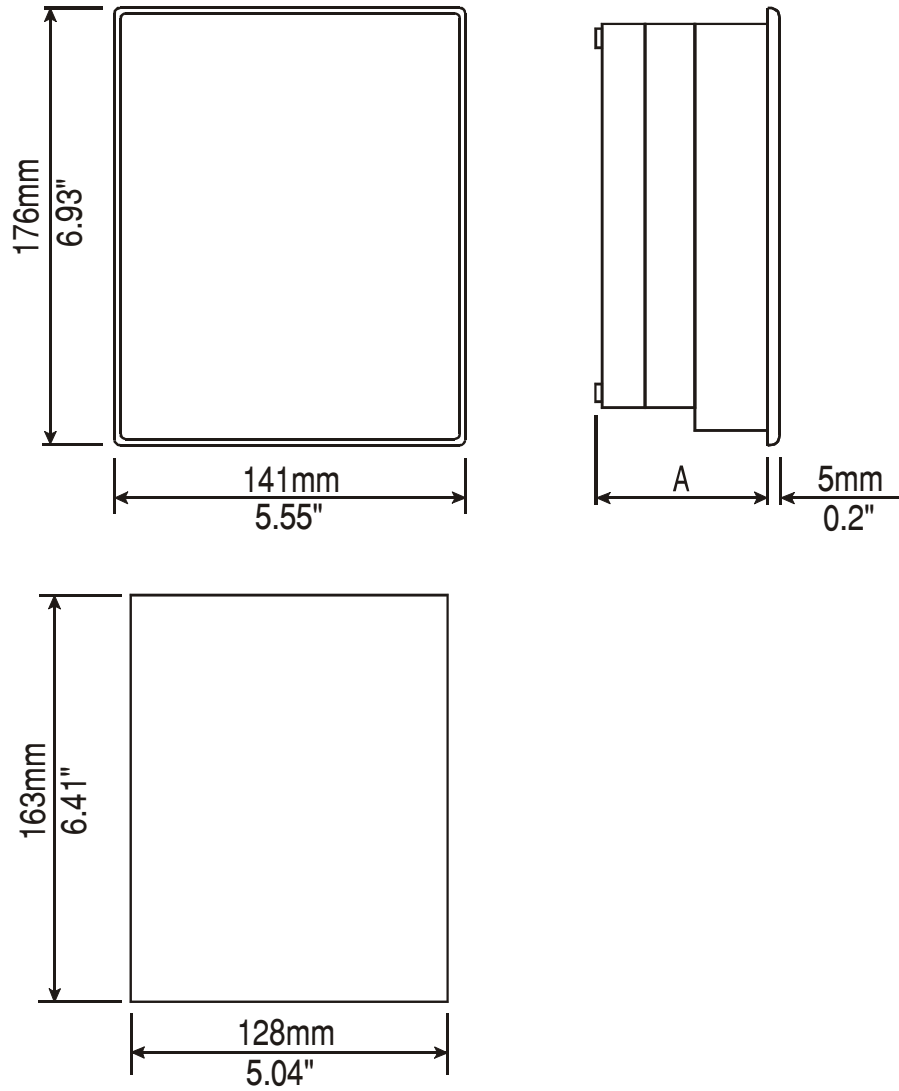
MD01R-02, MD02F-02, MD02G-04, MD02R-04, MD03R-02, MD03R-04



A = 74mm 2.91" for operator panel which have suffix A6, A7, 45.
 82mm 3.2" for operator panel which have suffix 50

Figure 2 - Dimensions

CP10G-04, CP11G-04



A = 71mm 2.8" for operator panel which have suffix A6, A7, 45.
 75mm 2.9" for operator panel which have suffix 50

Figure 3 - Dimensions

CP01F-02, CP01R-04, CP02F-02, CP02R-04, CP05R-04

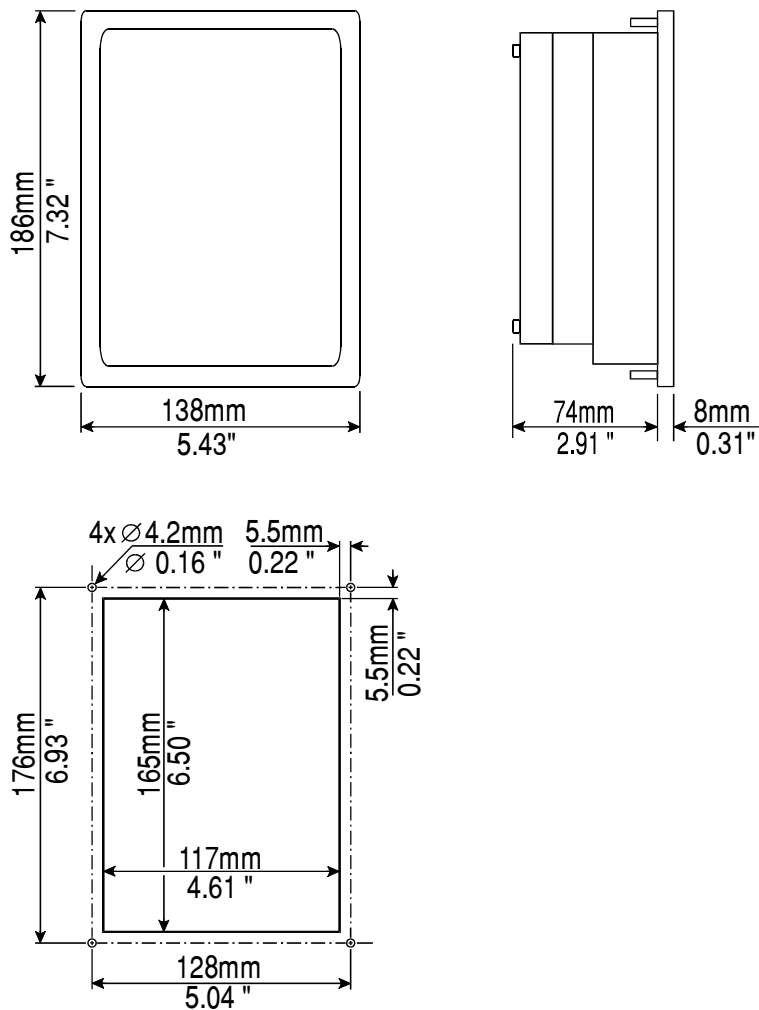


Figure 4 - Dimensions

CP04F-04

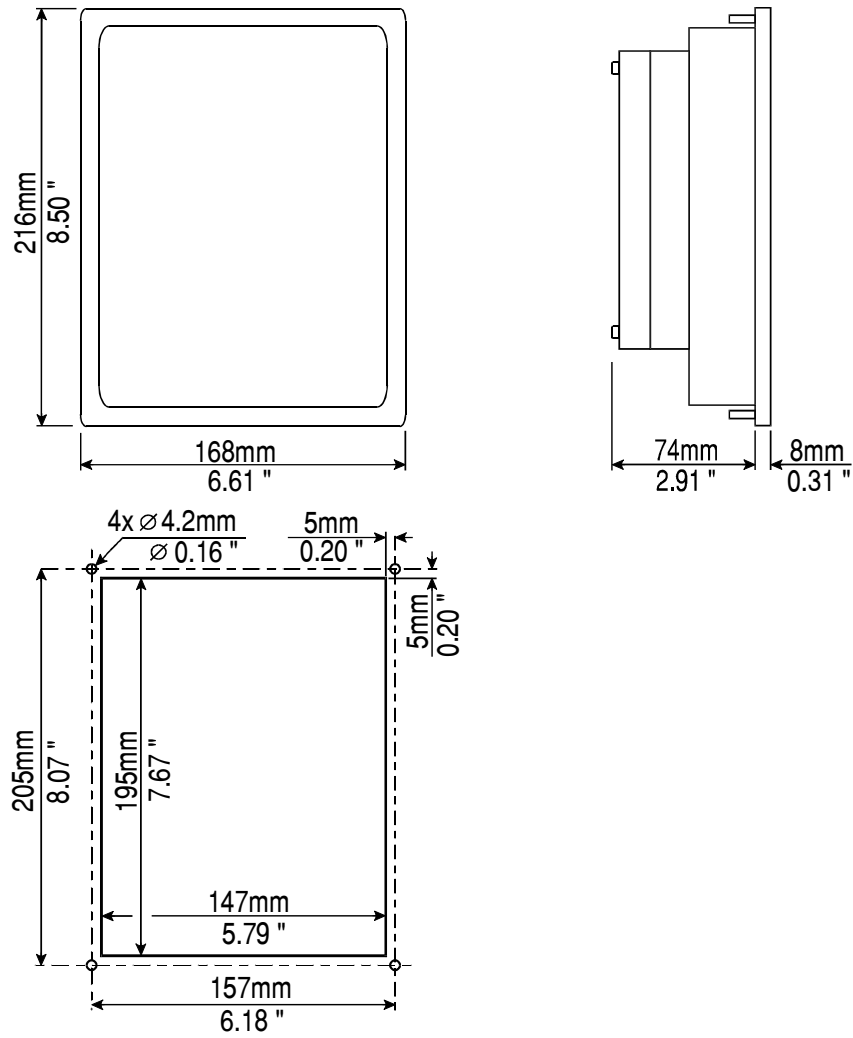


Figure 5 - Dimensions

BKDC-16, BKDC-16T, BKDL-16, BKDL-16T, BKDR-16, BKDR-16T, ECT-16, ELT-16, ERT-16

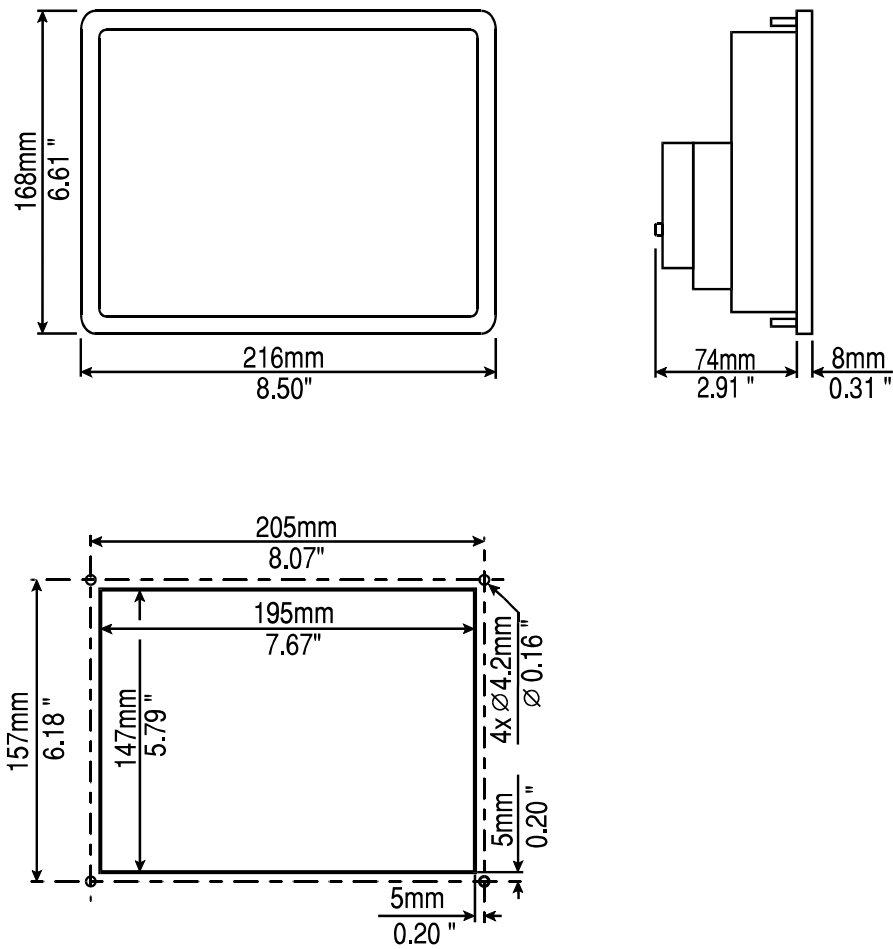


Figure 6 - Dimensions

UniOP

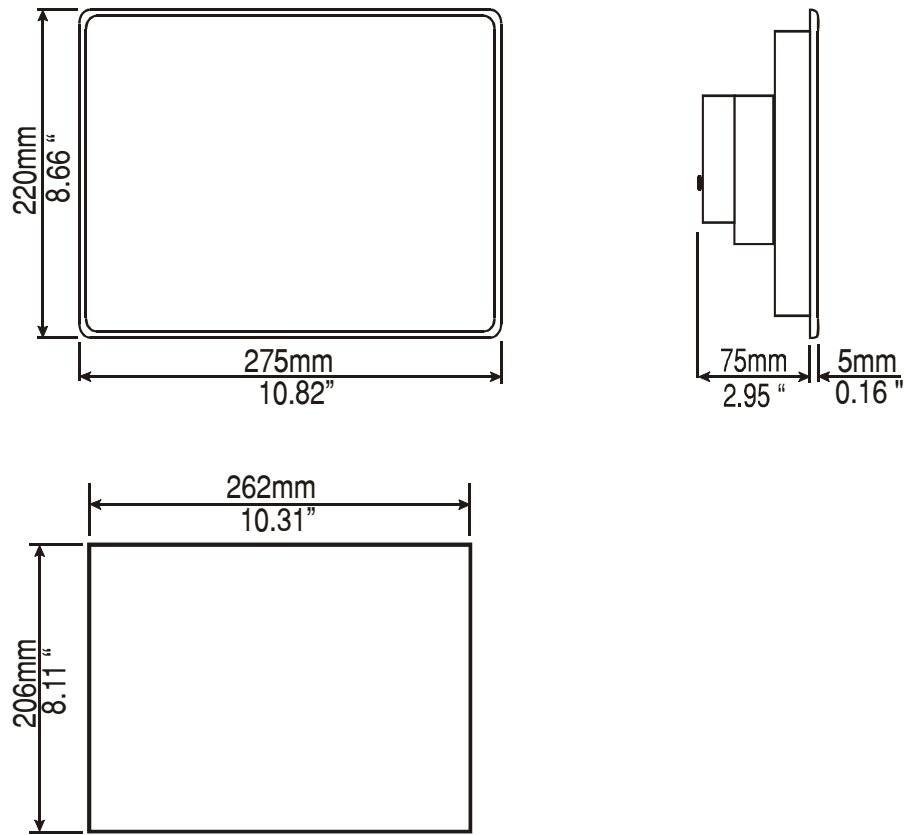
BKDC-46, BKDR-46

Figure 7 - Dimensions

EF-02, EF-04, ER-04, MKDR-05, MKDG-05

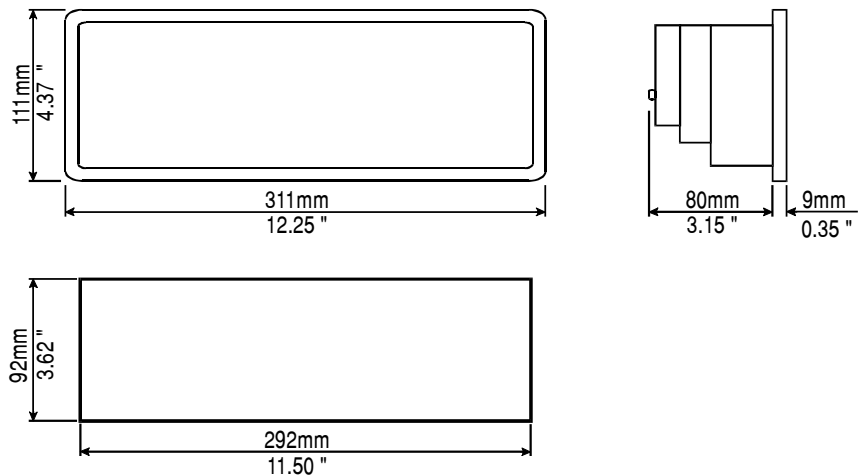


Figure 8 - Dimensions

EL-16N, ER-16, ER-16TA, MKDF-02, MKDF-04, MKDR-04

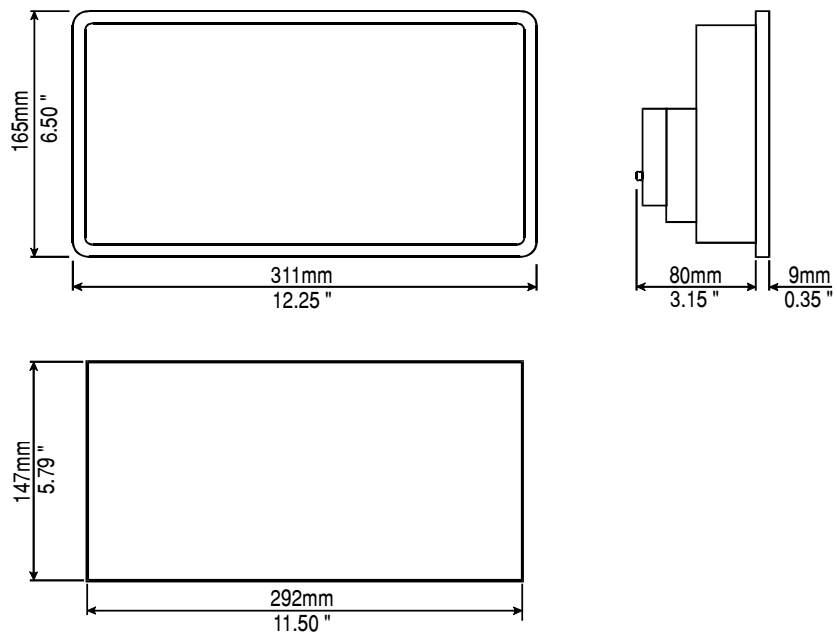


Figure 9 - Dimensions

UniOP

eTOP05

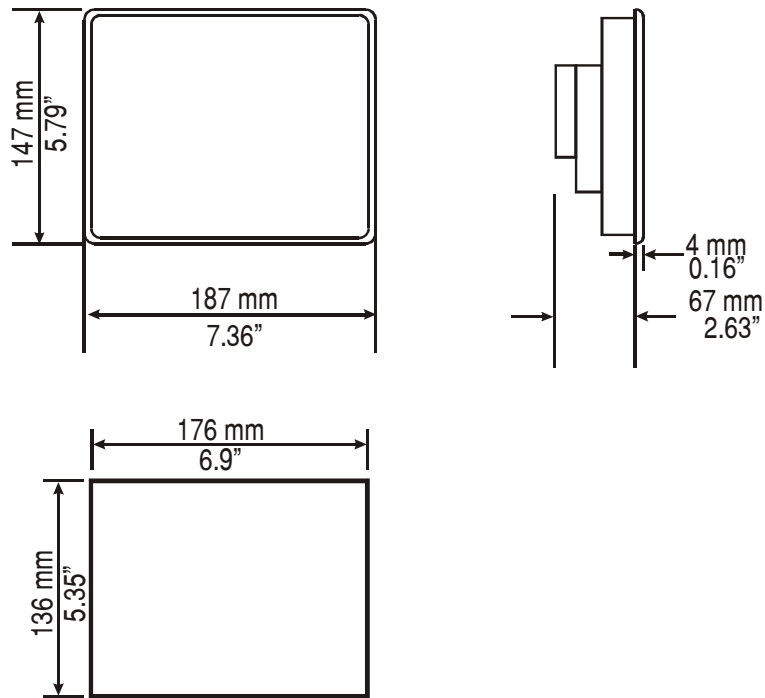


Figure 10 - Dimensions

eTOP10, eTOP11, eTOP12

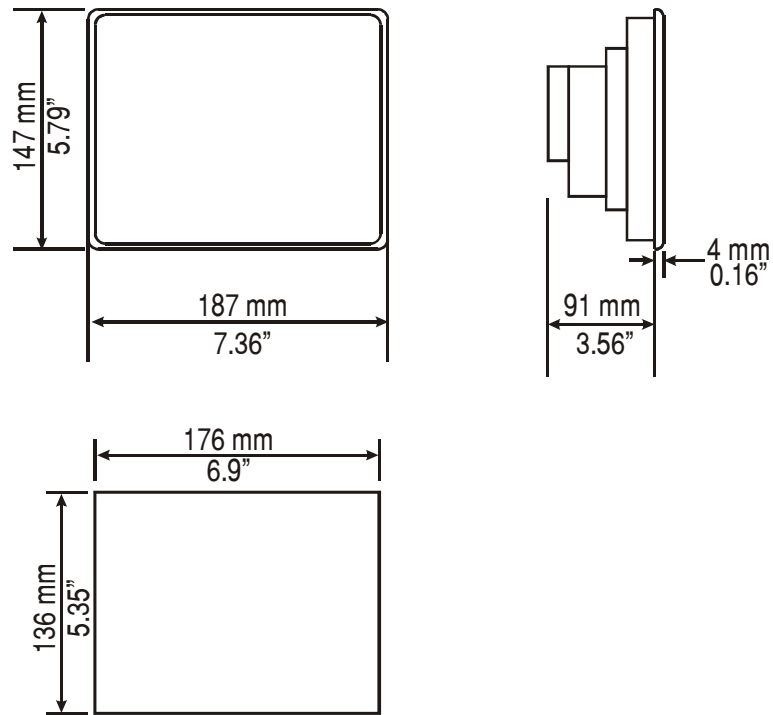


Figure 11 - Dimensions

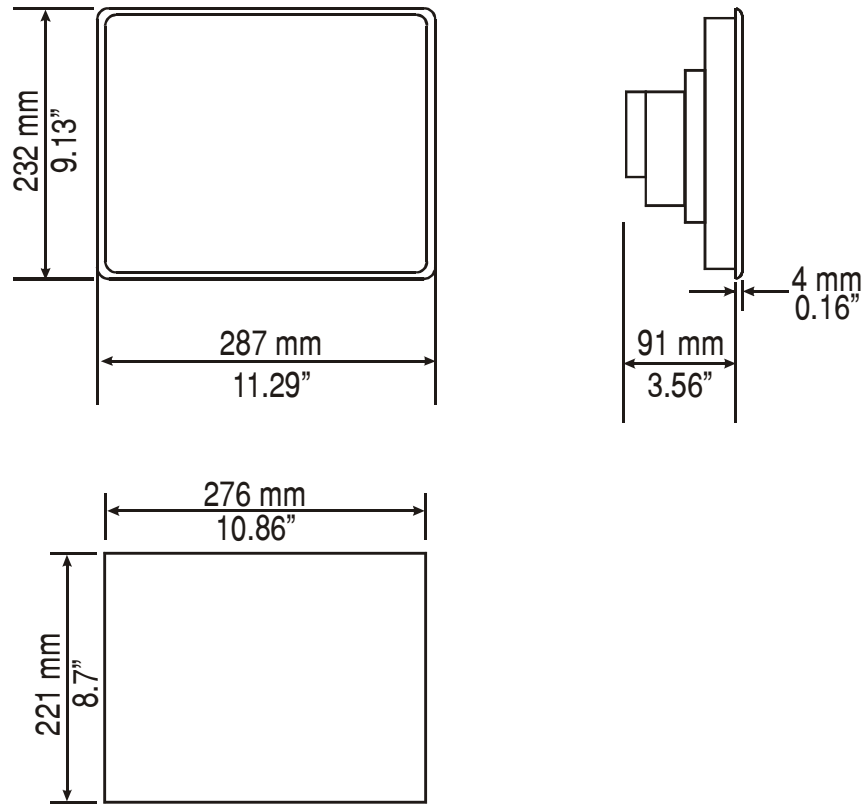
eTOP30, eTOP31, eTOP32, eTOP33

Figure 12 - Dimensions

eTOP40

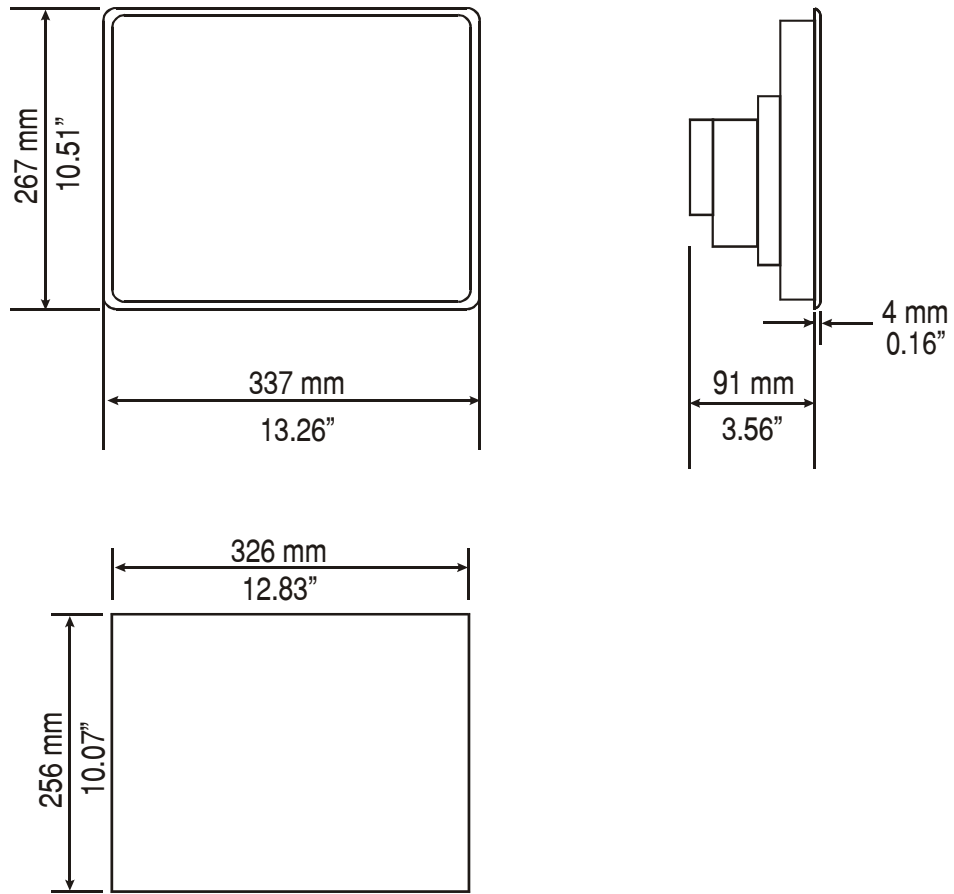


Figure 13 - Dimensions

eTOP50

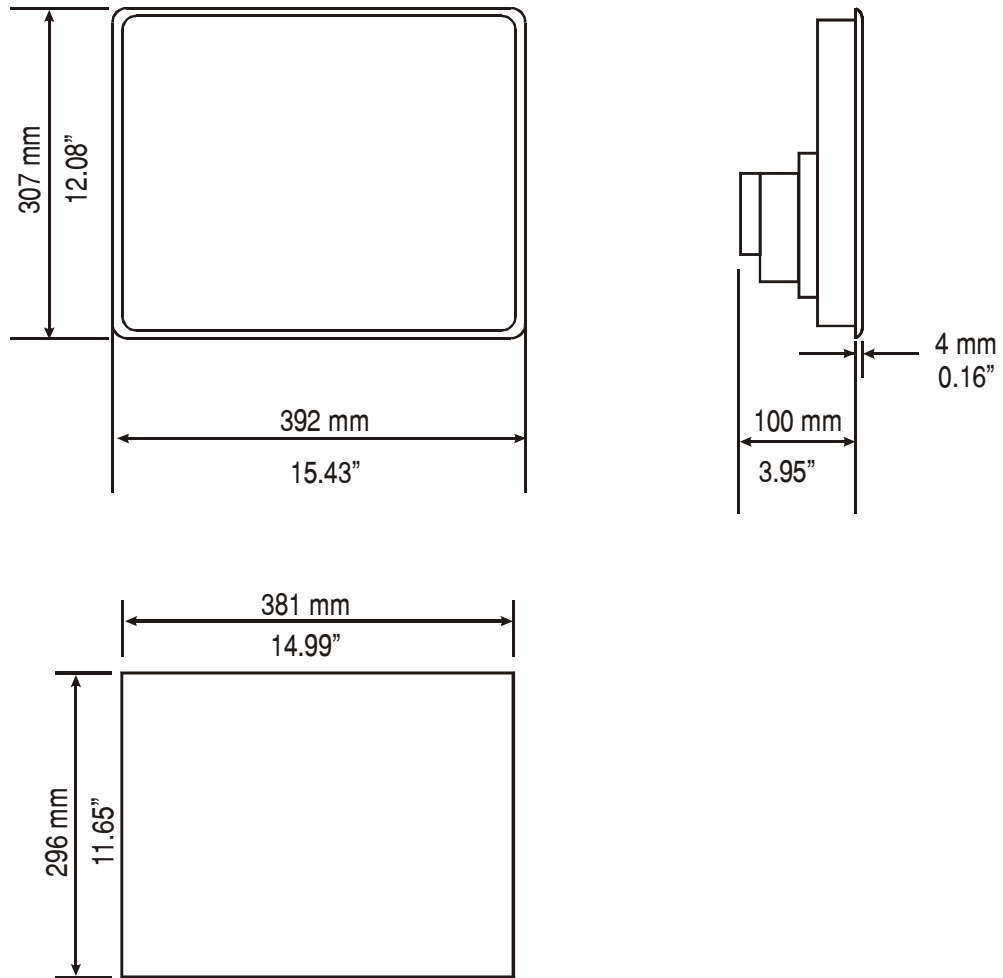
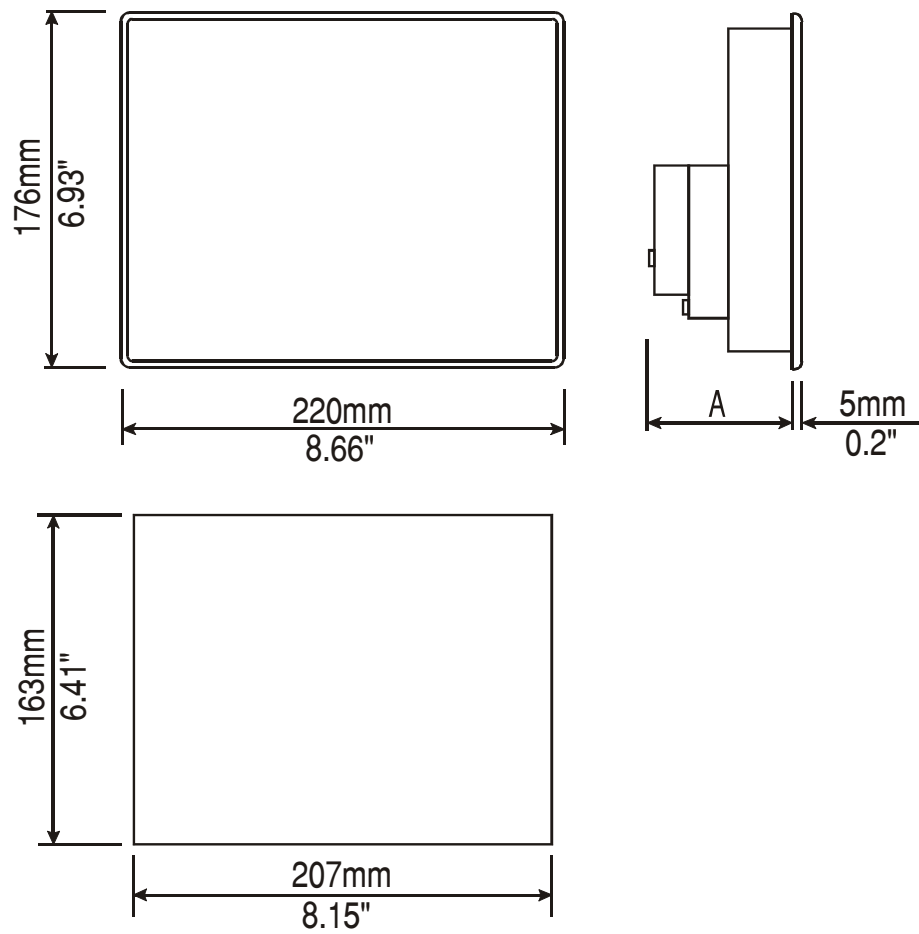


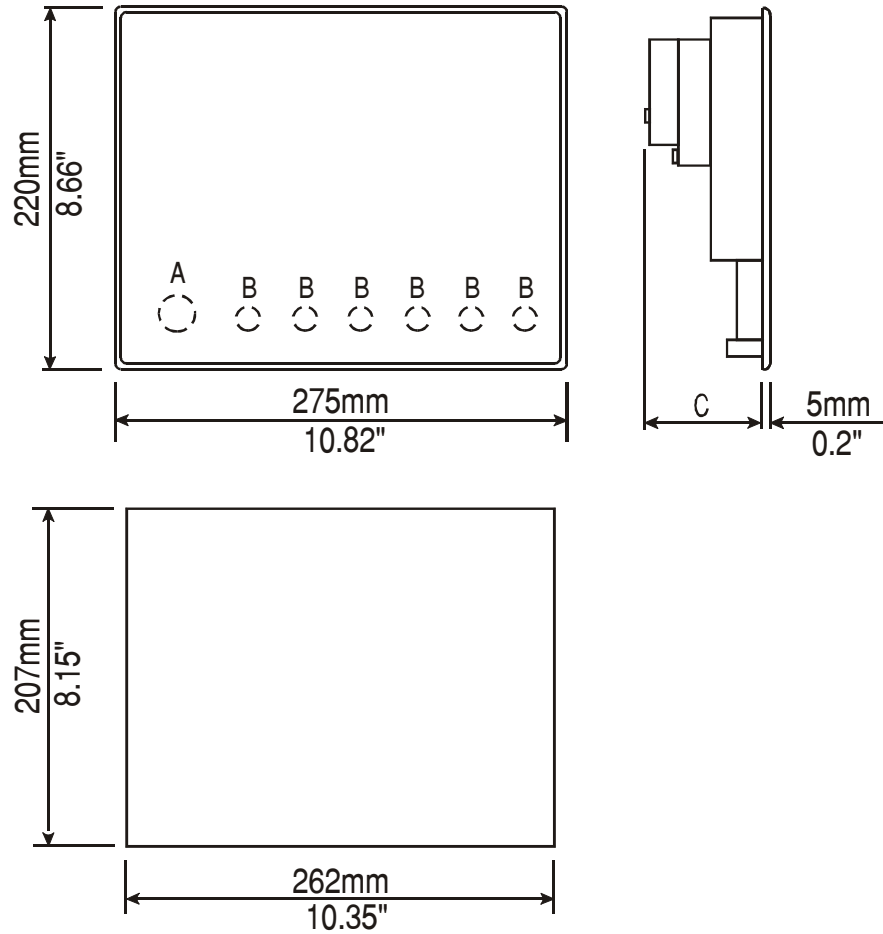
Figure 14 - Dimensions

MKDG-06

A = 68mm 2.8" for operator panel which have suffix A6, A7, 45.
80mm 3.1" for operator panel which have suffix 50.

Figure 15 - Dimensions

CP12G-04, CP13G-04, MKDG-07



- A = hole for switch, 22mm diameter.
- B = holes for switches, 16mm diameter.
- C = 71mm 2.8" for operator panel which have suffix A6, A7, 45.
80mm 3.1" for operator panel which have suffix 50.

Figure 16 - Dimensions

**ECT-VGA, ELT-VGA, EL-VGA, ER-25, ER-25T, ER-VGA,
ERT-VGA, ETT-VGA, MKDL-16N, MKDR-16, MKDR-16TA,
TP01R-16, TP01C-16.**

Note: TP01C-16 and TP01R-16 dimensions are the same as shown below, but rotated 90 degrees so that the height and width dimensions are reversed.

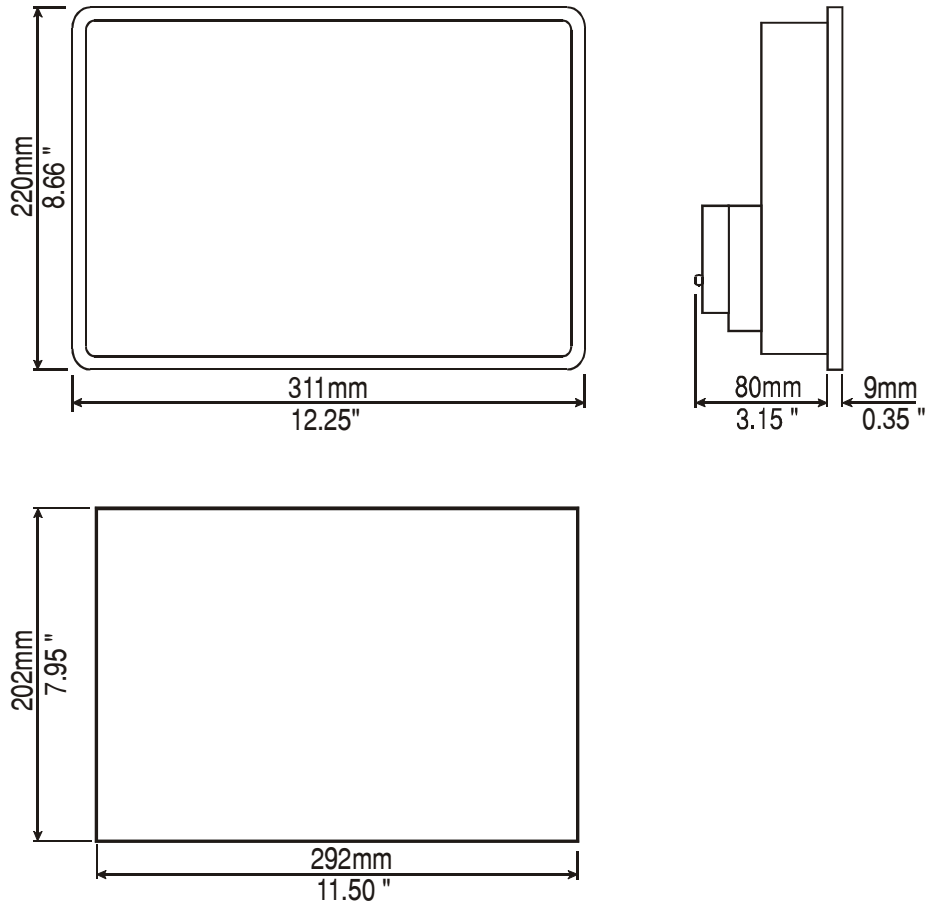


Figure 17 - Dimensions

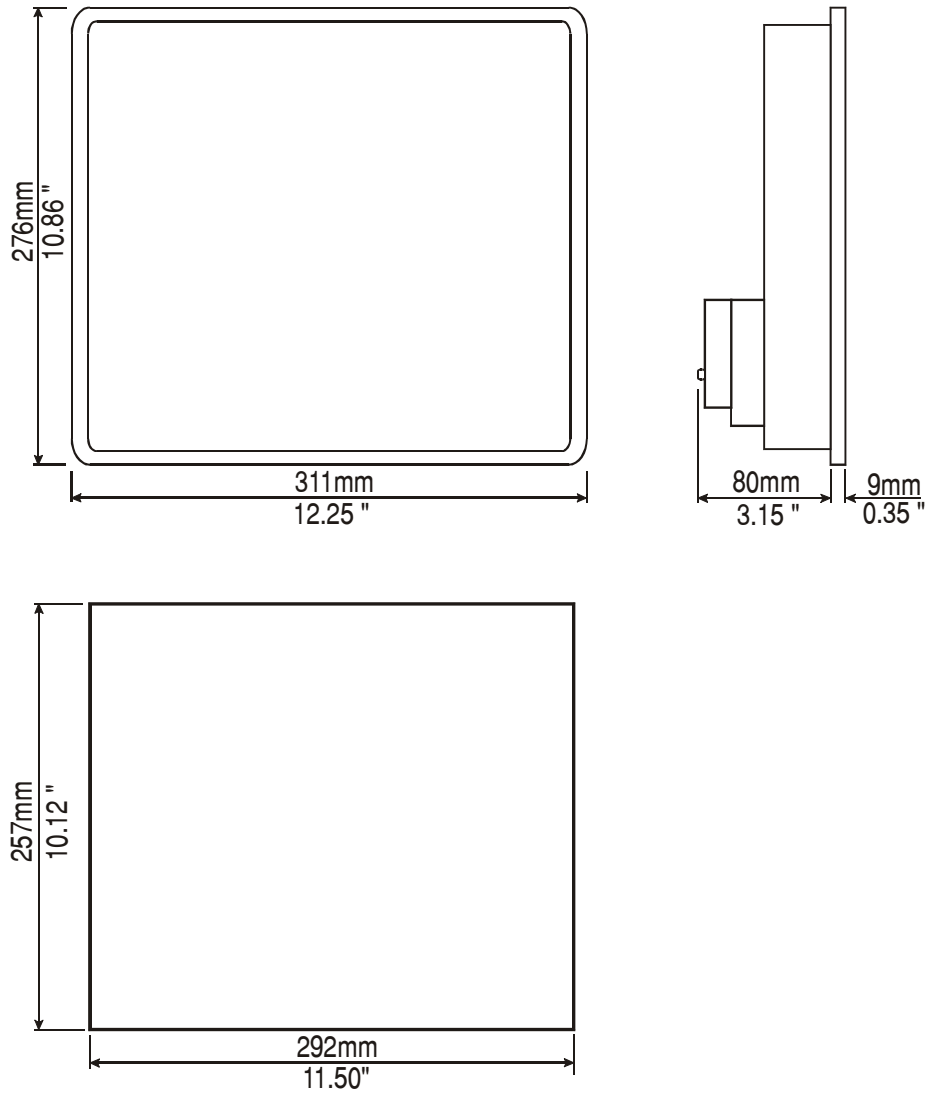
MKDC-VGA, MKDC-VGA-T, MKDL-VGA, MKDR-25, MKDR-VGA, MKDR-VGA-T, MKDT-VGA, MKDT-VGA-T

Figure 18 - Dimensions

ePAD30, ePAD30T, ePAD31, ePAD31T, ePAD32, ePAD32T, ePAD33, ePAD33T.

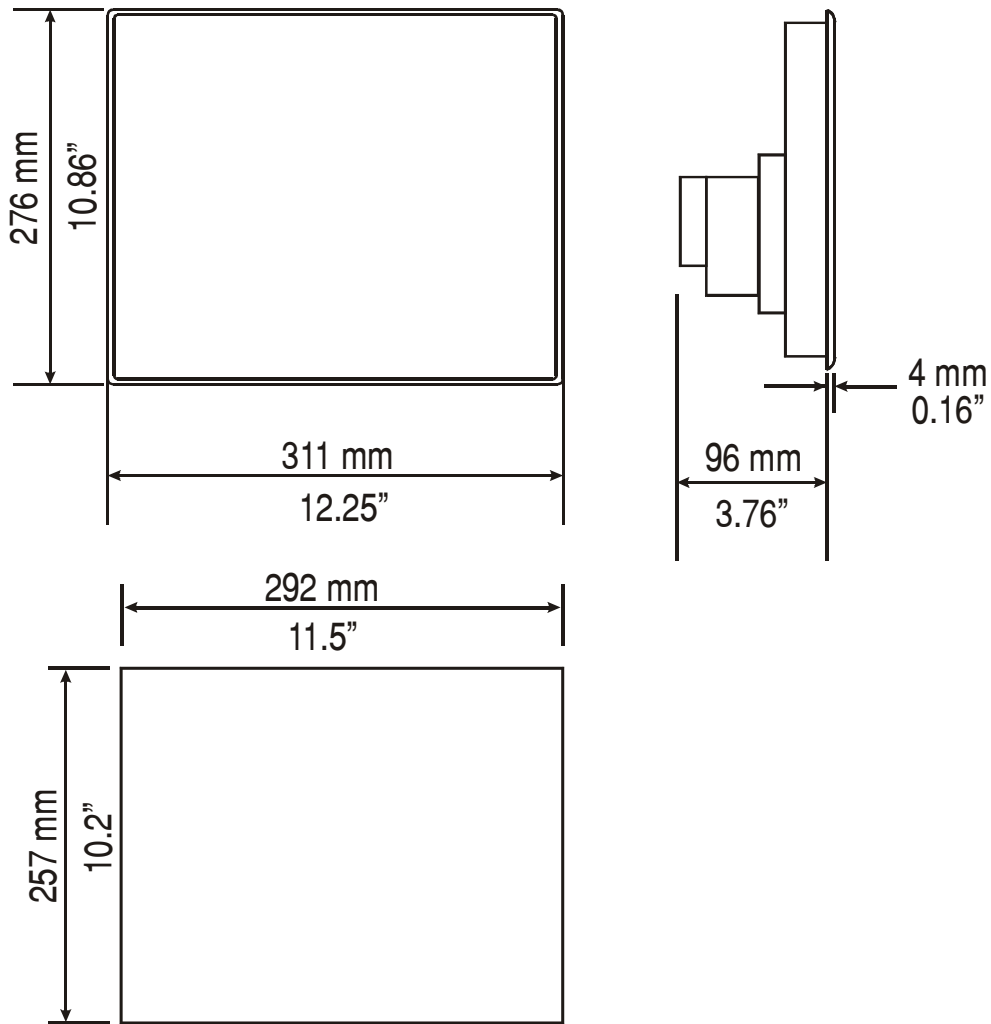


Figure 19 - Dimensions

Connections

MD00G-04, MD00R-02, MD00R-04

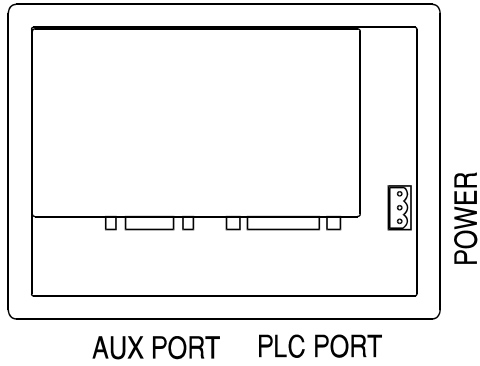


Figure 20 - Connectors

MD01R-02, MD03R-02, MD03R-04

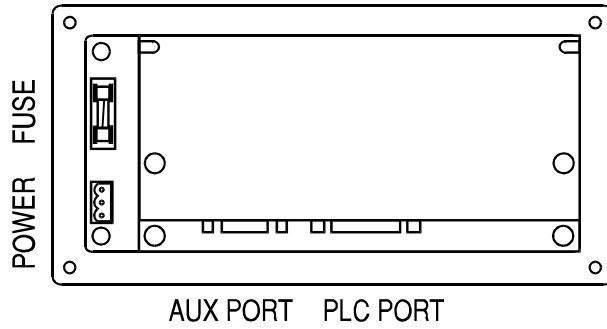


Figure 21 - Connectors

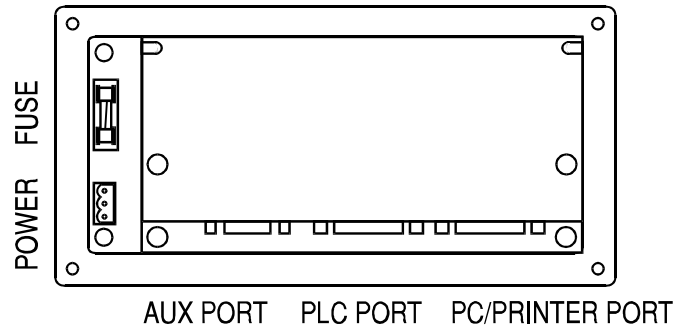
MD02F-02, MD02R-04

Figure 22 - Connectors

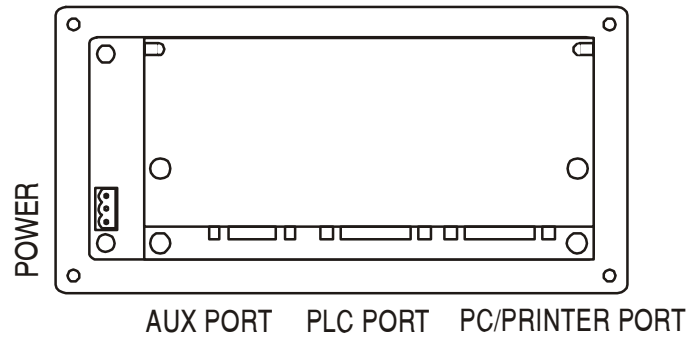
MD02G-04

Figure 23 - Connectors

CP05R-04

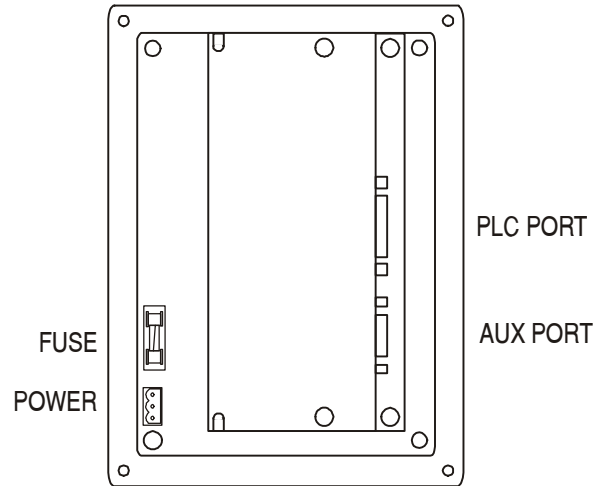


Figure 24 - Connectors

CP01F-02, CP01R-04, CP02F-02, CP02R-04

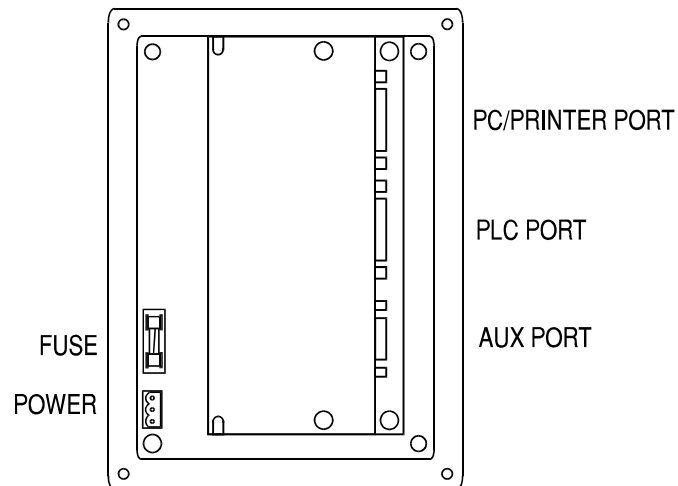


Figure 25 - Connectors

CP11G-04

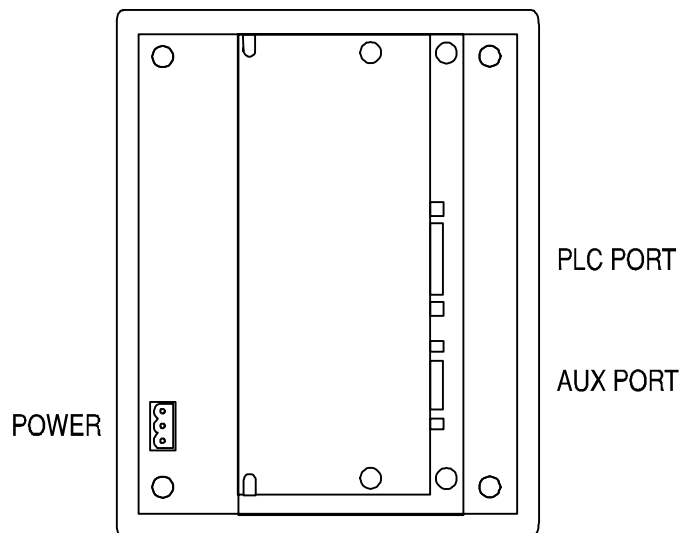


Figure 26 - Connectors

CP10G-04

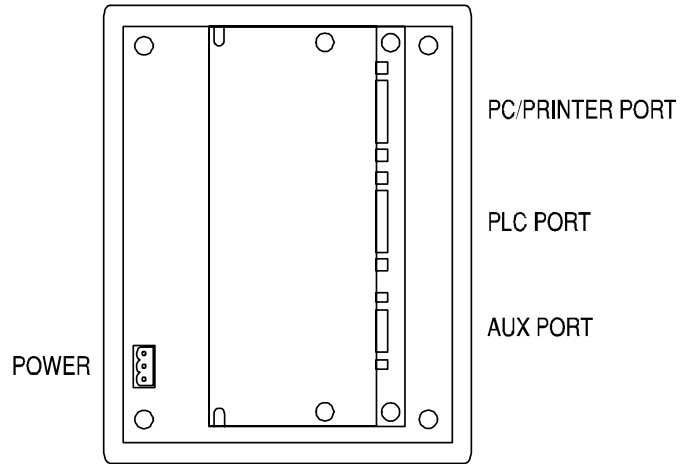


Figure 27 - Connectors

CP04F-04, CP04F-04G

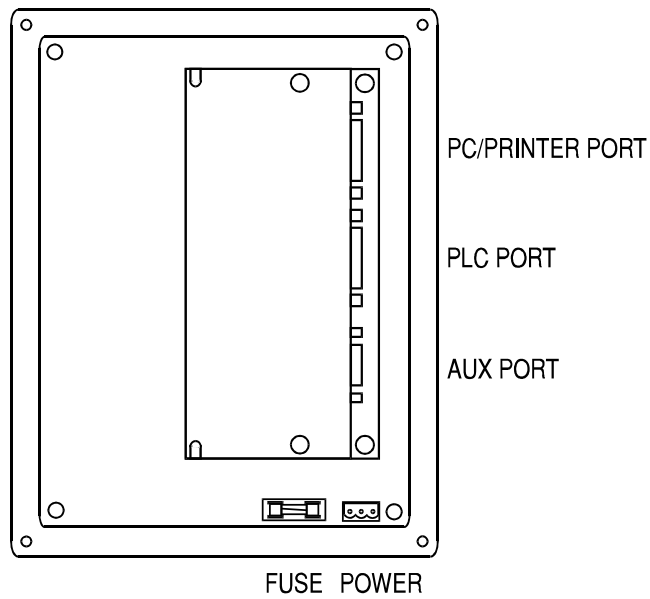


Figure 28 - Connectors

BKDC-16, BKDC-16T, BKDL-16, BKDL-16T, BKDR-16, BKDR-16T, ECT-16, ELT-16, ERT-16

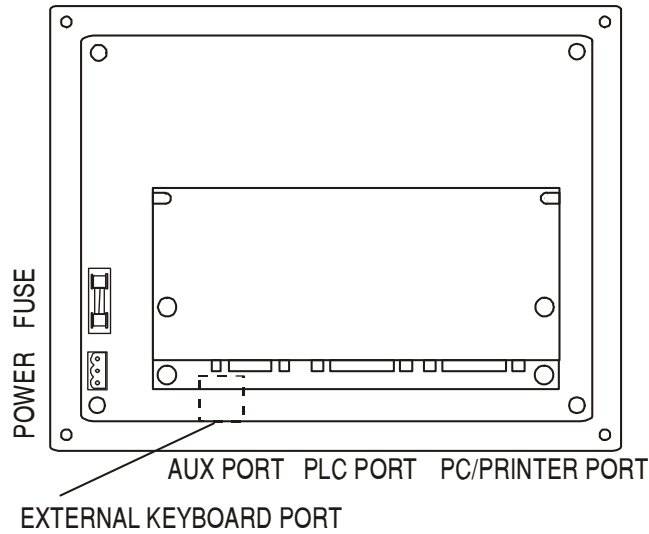


Figure 29 - Connectors

MKDG-06

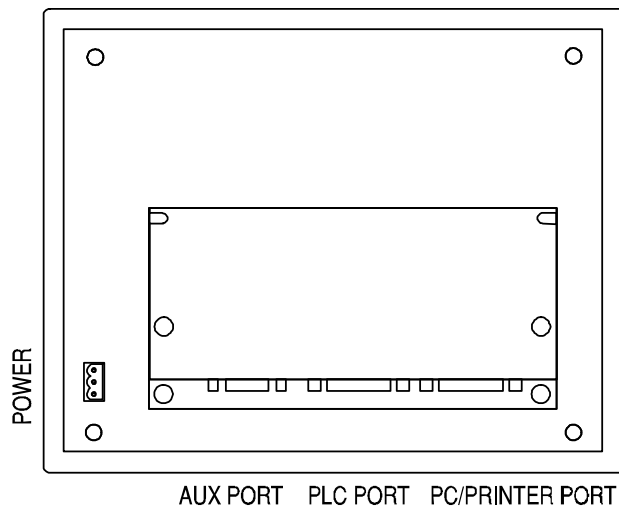


Figure 30 - Connectors

eTOP05

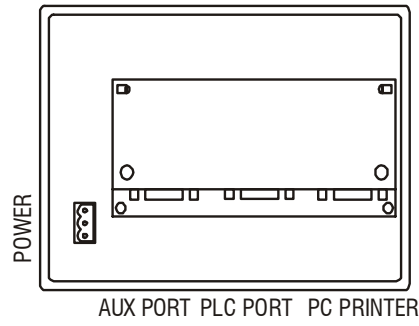


Figure 31 - Connectors

eTOP10, eTOP11, eTOP12, eTOP30, eTOP31, eTOP32, eTOP33, eTOP40, eTOP50

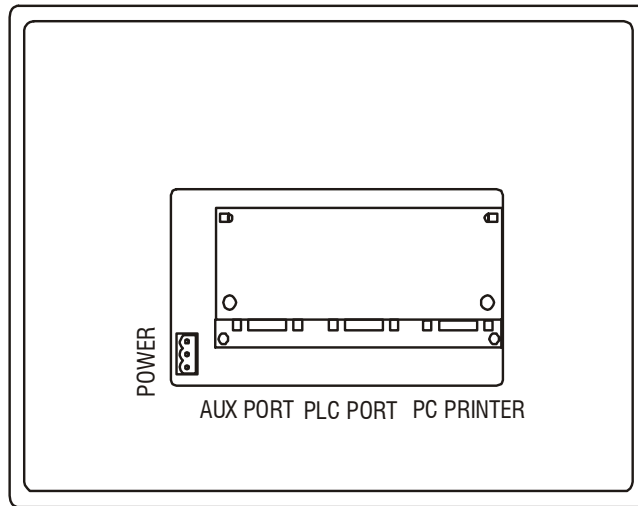


Figure 32 - Connectors

EF-02, EF-04, ER-04, MKDR-05, MKDG-05

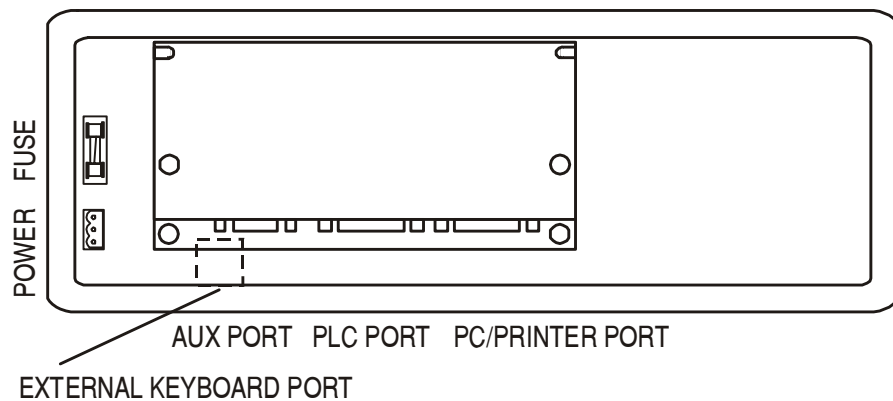


Figure 33 - Connectors

EL-16, EL-16N, ER-16, ER-16TA, MKDF-02, MKDF-04, MKDR-04

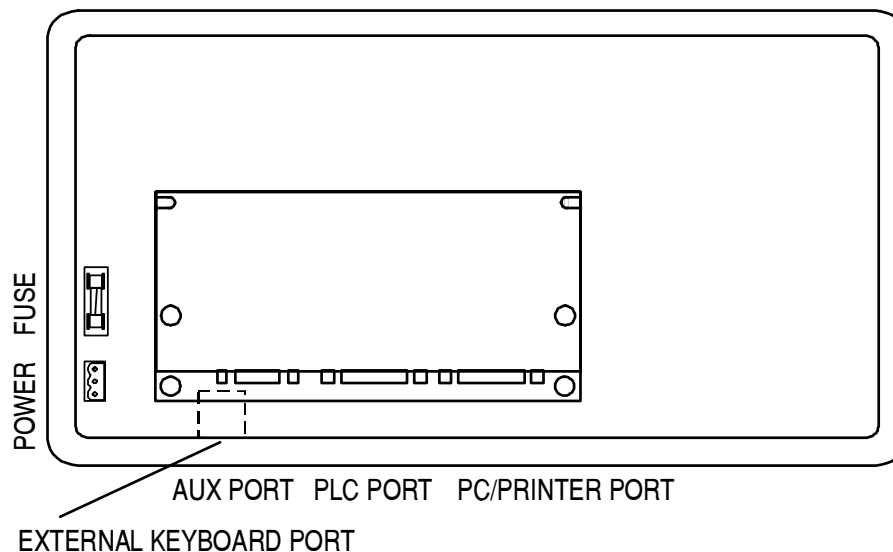


Figure 34 - Connectors

BKDC-46, BKDR-46

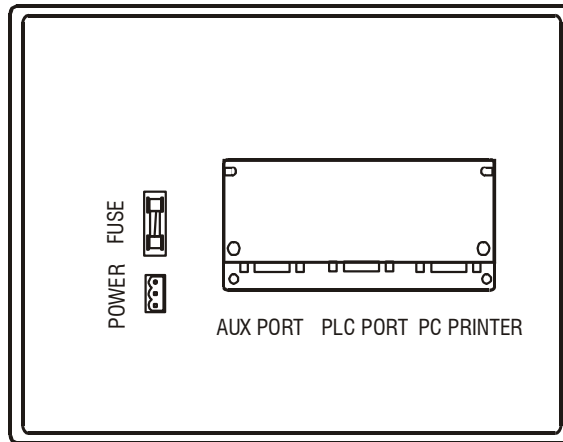


Figure 35 - Connectors

ECT-VGA, EL-25, EL-25T, ELT-VGA, EL-VGA, ER-25, ER-25T, ER-VGA, ERT-VGA, ETT-VGA, MKDL-16, MKDL-16N, MKDR-16, MKDR-16TA, TP01C-16, TP01R-16

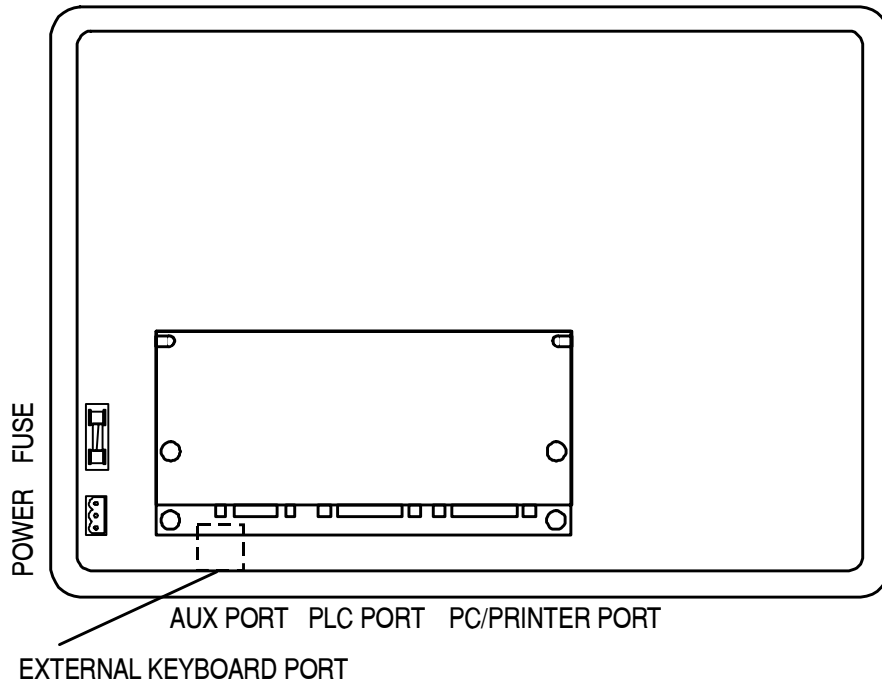


Figure 36 - Connectors

CP13G-04

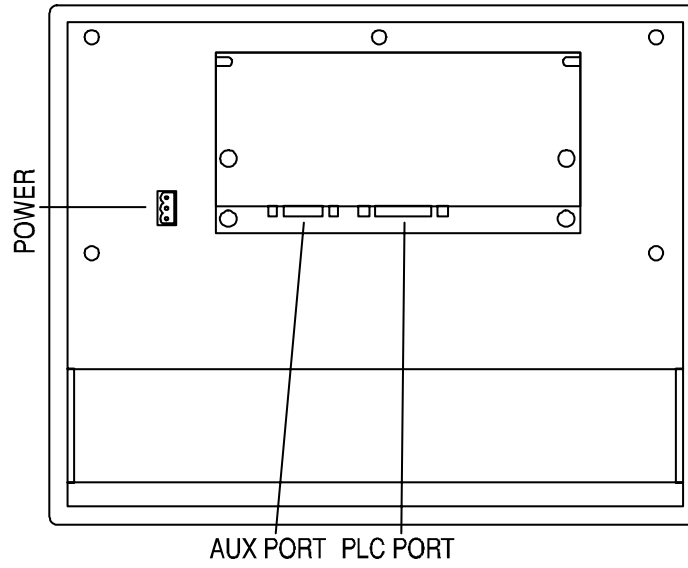


Figure 37 - Connectors

CP12G-04, MKDG-07

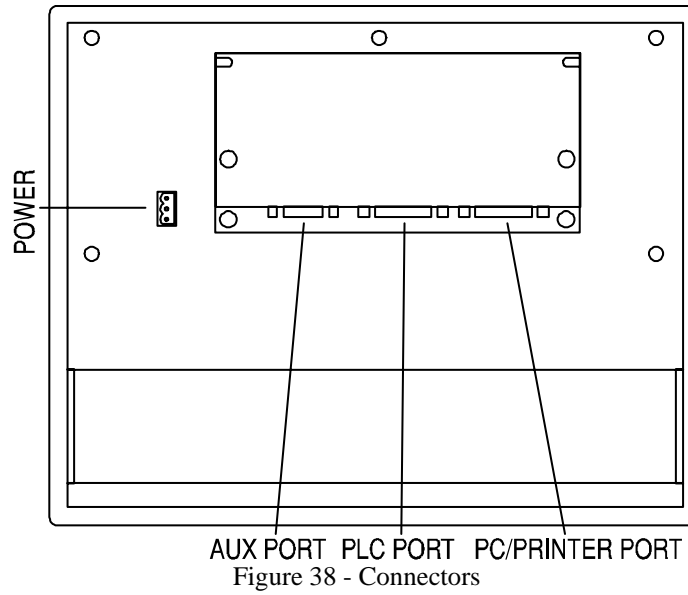


Figure 38 - Connectors

MKDC-VGA, MKDC-VGA-T, MKDL-25, MKDL-VGA, MKDR-25, MKDR-VGA, MKDR-VGA-T, MKDT-VGA, MKDT-VGA-T

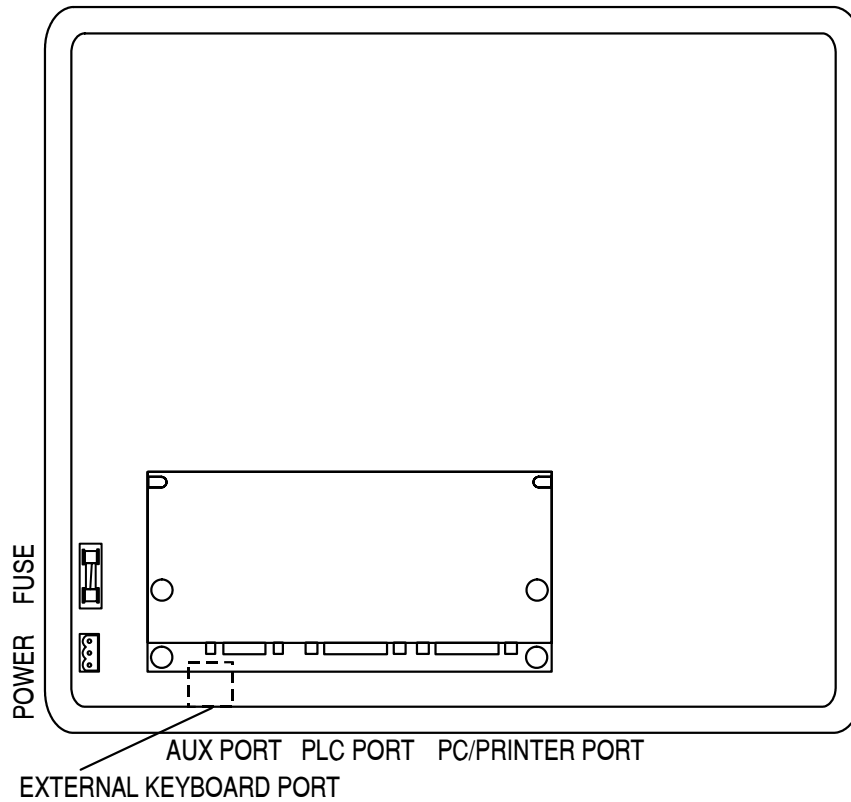


Figure 39 - Connectors

ePAD30, ePAD30T, ePAD31, ePAD31T, ePAD32, ePAD32T, ePAD33,
ePAD33T.

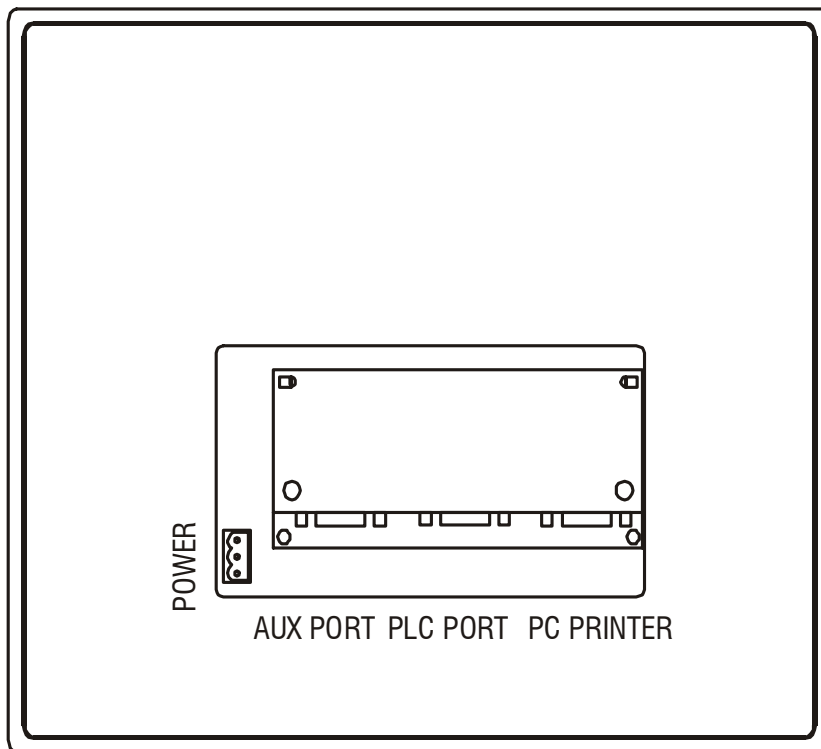


Figure 40 - Connectors

Power Supply and Grounding

The power supply terminal block is shown in the figure below. The terminal block is included with the panel.

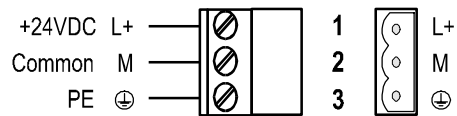


Figure 41 - Power supply terminal block

Note: ensure that the power supply has enough power capacity for the operation of the equipment.

The unit must always be grounded to protection earth (PE). Grounding helps limit the effects of noise due to electromagnetic interference on the control system.

Earth connection will have to be done using either either the screw or the faston terminal located near the power supply terminal block. A yellow label help identify the ground connection. Also connect to ground the terminal 3 on the power supply terminal block.

The power supply circuit may be floating or grounded. In the latter case connect to ground the power source common as shown in figure 42 with a dashed line.

When using the floating power scheme, note that the panels internally connect the power common to ground with a 1 M Ω resistor in parallel with a 10 nF capacitor.

The power supply must have double or reinforced insulation

The suggested wiring for the power supply is shown in figure 42.

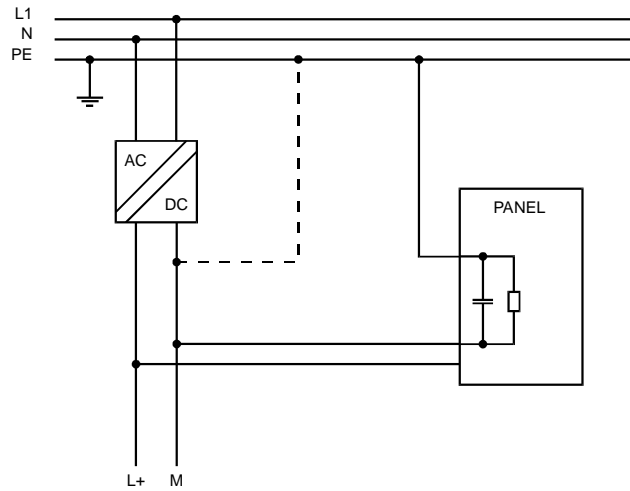


Figure 42 - Power supply

All the electronic devices in the control system must be properly grounded. Grounding must be performed according to applicable regulations.

PLC Port

The PLC Port is used to communicate with the PLC or with another type of controller; if the panel is configured as an UniNET client, then this port may be used for the network connection.

Different electrical standards are available for the signals in the PLC port connector: RS-232, RS-422, RS-485 or Current Loop 20 mA. The cable used selects the appropriate signals. It is always necessary to use the correct cable type for on the PLC to be connected.

Note: If the proper cable is not used, communication with the PLC will not be possible.

The connector is a D-15 pin male. Pin assignment is shown in the table below.

Pin	Description
1	Frame Ground
2	RXD
3	TXD
4	+5 V output (Max 100mA)
5	GND
6	CHA-
7	CHB-
8	TX+ 20 mA
9	TX- 20 mA
10	RTS
11	CTS
12	RX+ 20 mA
13	RX- 20 mA
14	CHA+
15	CHB+

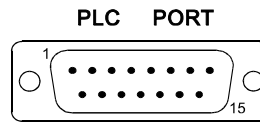


Figure 43 - PLC Port connector and pin assignment

The communication cable must be chosen for the type of device being connected.

PC/Printer Port

The function of the PC/Printer Port depends on the mode of operation of the panel.

Configuration Mode	programming port
Operation Mode, UniNET Server	connection to UniNET
Operation Mode, UniNET not active or Client node	connection to serial printer

Only RS232 signals are available on the PC/Printer Port. The connector is a D-15 pin female. Pin assignment is shown in the table below.

UniOP

Pin	Description
1	Frame Ground
2	RXD
3	TXD
4	+5 V output (max 100mA)
5	GND
6	Reserved
7	Reserved
8	Reserved
9	Reserved
10	RTS
11	CTS
12	Reserved
13	Reserved
14	Reserved
15	Reserved

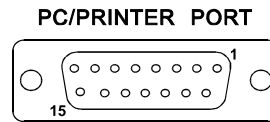


Figure 44 - PC/Printer Port connector and pin assignment

Use cable CA2 to connect the panel to a PC for programming. The diagram is shown in the figure below. The connector is a D-9 pin female.

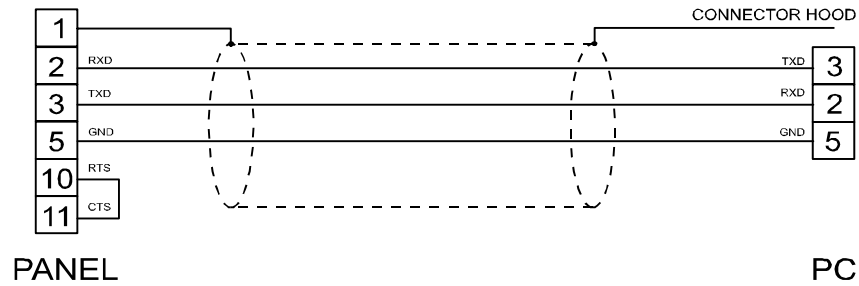


Figure 45 - Programming cable CA2

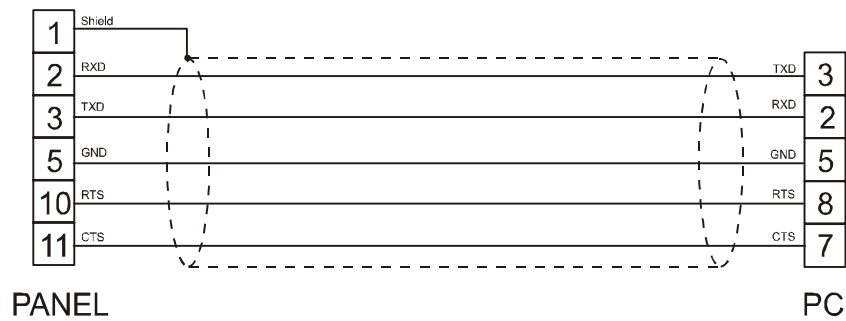


Figure 46 - Programming cable CA114

When the panel is in Operation Mode and is not as a UniNET Server, you can attach a serial printer to the PC/Printer Port. The communication parameters for the printer are defined by the application program (project file)

Note: the communication cable to the printer depends on the communication interface of the printer.

AUX Port

The AUX Port is a communication port specially designed for industrial network communication. The AUX Port connector is a 9 pin D sub type. The functionality of the AUX Port depends on the optional communication module which is plugged into the unit.

Note: The pin assignment of the Aux Port connector is described in the manual of the communication module.

The procedure to mount the communication modules is the following:

- 1) turn off the unit
- 2) partially unscrew with a screwdriver the 2 screws holding the rear cover. The screws are labelled 'A' in Figure 47
- 3) remove the cover (for eTOP05/10/11/12/30/31/32/33/40/50 and ePAD30, ePAD30T, ePAD31, ePAD31T, ePAD32, ePAD32T, ePAD33, ePAD33T lever with screwdriver on the slot on the cover's side).
- 4) plug the module in the red connectors; make sure the connectors are locked
- 5) replace the rear cover
- 6) fix the 2 screws 'A' (for eTOP05/10/11/12/30/31/32/33/40/50 and ePAD30, ePAD30T, ePAD31, ePAD31T, ePAD32, ePAD32T, ePAD33, ePAD33T close the cover with a little pressure).
- 7) stick in the area 'B' the label describing the functionality of the AUX Port. The label is delivered with the modules

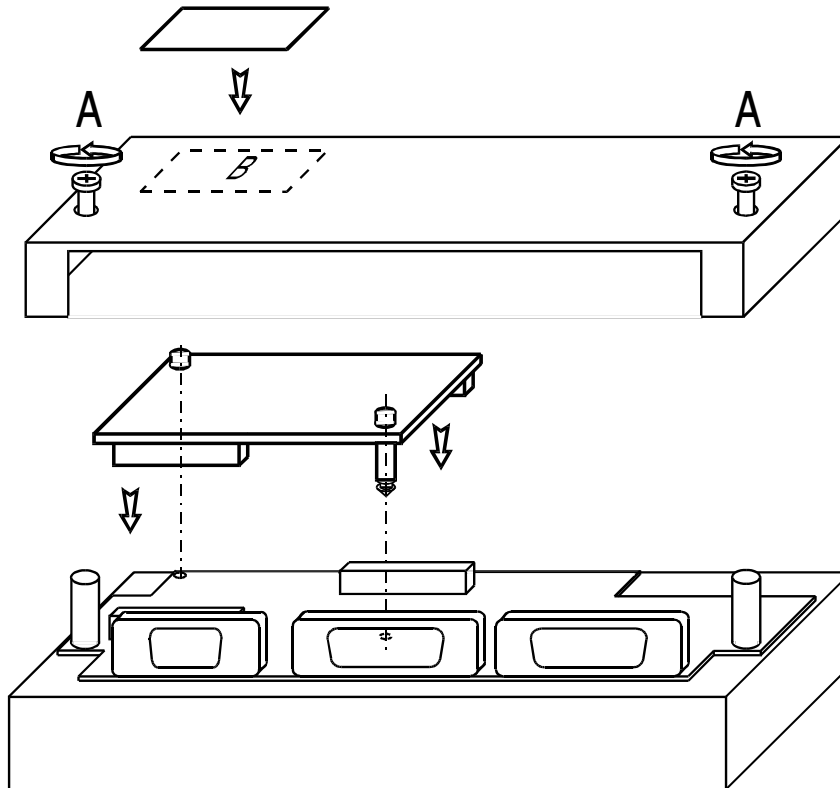


Figure 47 - Mounting the communication modules

Models without the PC/Printer Port

Some UniOP models, see Table 1, do not have the PC/Printer Port. The PLC Port will be referred to as the PLC/PC Port, and will be used as a programming port when the panel is in Configuration Mode. You must use a gender changer with the CA2/CA114 cable to program these units.

External Keyboard Port

Several UniOP models, see Table 1, are equipped with a connector designed to connect an external keyboard type ET-F or AT-F. The communication cable comes with the keyboards.


Battery Replacement

Some models require the use of the lithium battery for data back-up.

The following information is maintained by the battery:

- hardware real-time clock (date and time)
- event list
- recipe data

UniOP panels signal the battery status in more than one way:

- blinking of the LED indicator FAULT or FLT (when available) or 
- with the 'Battery' field in System Menu (BATTERY OK or LOW)
- with the value of the S6 bit in the RDA

When the panel signals that the battery is low, you should replace the battery as soon as possible.

Note: Replacing the battery will cause the loss of the data maintained by the battery.

To replace the battery, follow the procedure listed below:

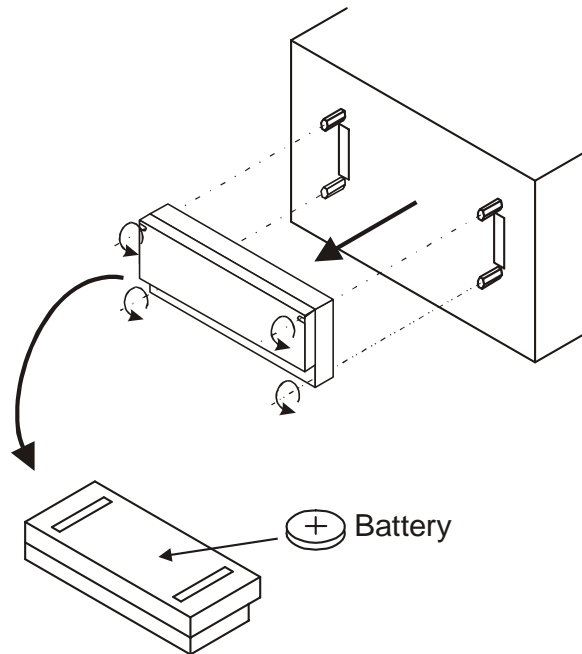


Figure 48 - battery replacement

- 1) turn off the power to the panel
- 2) use a screwdriver to loose the four screws securing the block composed by the two metal units
- 3) remove the block
- 4) remove the battery
- 5) replace the battery with a new one

***Note:CAUTION!** Danger of explosion if battery is incorrectly replaced .Replace only with the same or equivalent type recommended by the manufacturer.Dispose of used batteries according to the manufacturer's instructions.*

- 6) replace the block; tighten the four screws
- 7) apply power to the panel and check that battery good status is signaled.

Removing the Legends

The keyboard legends can be removed in one step by grasping the exposed portion of the legend and sliding it downward.

Use the blank legends that come with the panel or other with equivalent thickness and consistency. Do not use legends thicker than ones included in the panel.

Dedicated LED's

The table below shows the name and the symbol (when available) of the LED's dedicated to special functions which may be available in the UniOP operator panels.





LED		Status	Meaning
Name/symbol	Color		
FAULT/FLT	red	OFF	No hardware problem detected; battery OK
		BLINK	Battery low
		ON	Hardware fault
DL	green	OFF	No keys are pressed and no errors
		BLINK	Communication error (not all models)
		ON	While any key is pressed (visual feedback)
	red	OFF	No hardware problem detected
		BLINK	Battery low
		ON	Hardware fault
	green	OFF	No keys are pressed
		ON	While any key is pressed (visual feedback)
RUN / 	green	OFF	Hardware fault
		ON	Unit in operation
COM / 	green	BLINK	Communication error
		ON	Communication OK
ALARM / 	red	OFF	No alarms
		BLINK	Alarm requires acknowledgment
		ON	Alarm active

Table 2 - Dedicated LED's

Usage and Safety Guidelines

Applicable Regulations

Regulations and recommendations have been issued in Europe covering the main safety-related issues in control systems which include operator interfaces. EN 60204-1 lists some important guidelines applicable when using operator interfaces.

- 9.2.4 Suspension of safeguards
- 9.2.5.3 Stop
- 9.2.5.4 Emergency stop
- 9.2.5.6 Hold-to-run controls
- 9.2.5.7 Two-hand controls
- 9.4 Control function in case of failure

Do not use operator interface to directly command motors, valves or other actuators not equipped with safeguards and potentially harmful to persons or equipment in case of fault to the unit.

The units are intended to be mounted on the front panel of a metallic cabinet. The service personnel, when operating directly on the powered unit, must be electrostatically discharged. All safety related regulations must be observed

CAUTION! *Don't open the panel rear cover when the power supply is applied.*

Installation Environment

The equipment is not intended for continuous exposure to direct sunlight. This might accelerate the aging process of the front panel film.

The equipment is not intended for installation in contact with corrosive chemical compounds. Check the resistance of the front panel film to a specific compound before installation.

Do not use tools of any kind (screwdrivers, etc.) to operate the keyboard of the panel or the touch screen.

UniOP

In order to meet the front panel protection classifications, proper installation procedure must be followed:

- the borders of the cutout must be flat
- screw up each fixing screw until the plastic bezel corner get in contact with the panel.
- The cutout for the panel must be of the dimensions indicated in this manual.
- Two types of gaskets are delivered with the UniOP panels, depending on the model, rectangular or linear.

Applying the rectangular gasket

- The gasket should be applied around the cutout prepared for the panel being careful not to place it under tension
- The gasket should be replaced every time that the panel is dismantled and remounted in its place

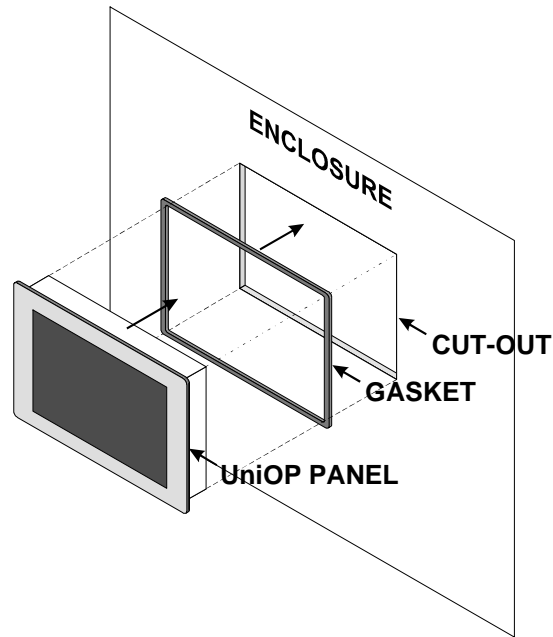


Figure 49 - panel with rectangular gasket installation

Applying the two linear gaskets:**Thin strip:**

- The gasket should be applied around the cutout prepared for the panel
- The gasket should be applied starting from the middle of the lower side being careful not to place it under tension
- The two ends of the gasket should meet without overlap
- The gasket should be replaced every time that the panel is dismantled and remounted in its place

Large strip:

- The gasket should be applied on the operator panel just behind the bezel
- The gasket should be applied starting from the 1/3 of the lower side being careful not to place it under tension
- The two ends of the gasket should meet without overlap
- The gasket should be replaced every time that the panel is dismantled and remounted in its place

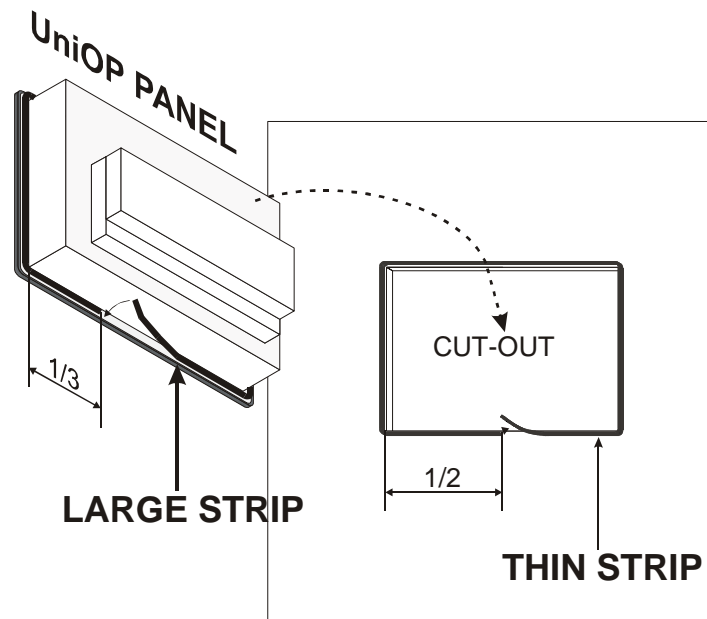


Figure 50 - panel with linear gaskets installation

Installation Procedures

Place the four fixing brackets on the longer side near the corners, as shown in figure (Figure 51). Screw each fixing screw until the plastic or aluminium bezel corner get in contact with the panel.

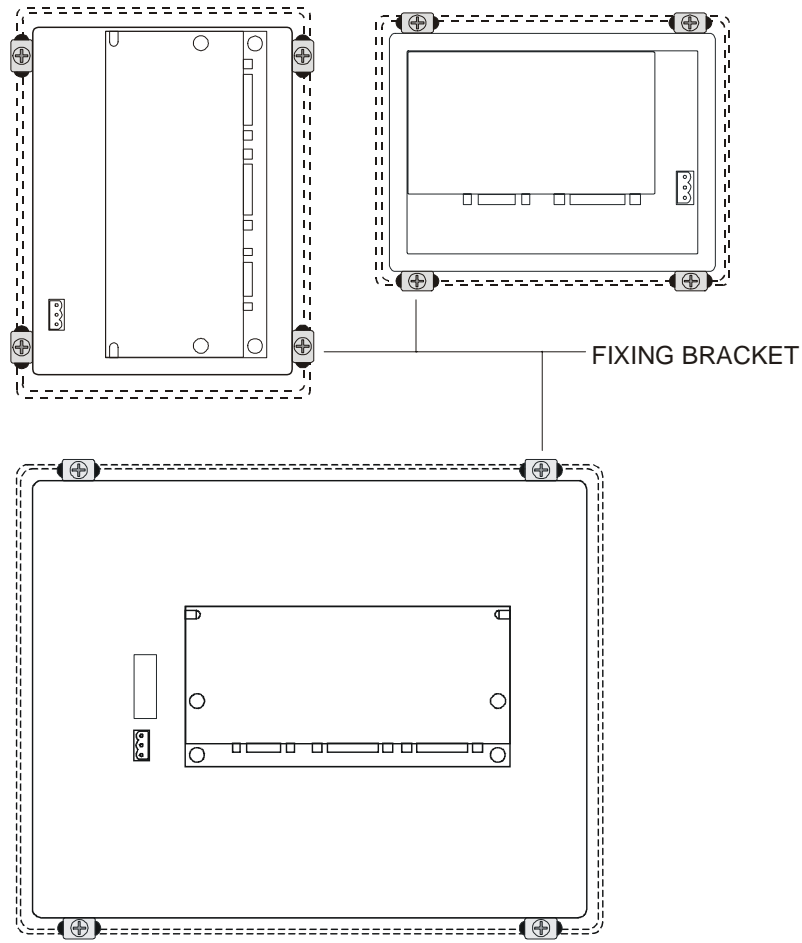


Figure 51 – Fixing bracket position

Cleaning Faceplates

The equipment must be cleaned only with a soft cloth and neutral soap product. Do not use solvents.

Handling the Memory Cards

The SSFDC memory cards used in some of the UniOP operator panels need to be handled with care when replaced in the memory slot of the panel.

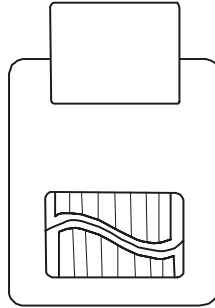


Figure 52 – SSFDC memory card

Before inserting the memory card in its slot in the panel, the contact area must be verified to be clean. Any track of contaminants such as oil or any greasy substances should be carefully removed.

Contamination on the golden contacts of the memory card, at the moment the media is inserted in the slot, may generate an insulating layer that may result in electrical contact problems with the sliding elements of the socket.

Corrosive / active chemicals may permanently damage the memory card golden surface. Any contact with such substances must be carefully avoided.

To ensure the proper operation of the memory media the contact surface of the SSFDC card should be cleaned with a soft, clean tissue.

Note: *The use of any synthetic cloth could permanently damage the memory card due to electrostatic discharge.*

Direct contact with the human body (fingers) with the contact area should be carefully avoided.

In case the memory card needs to be removed from the slot and carried around, it has to be kept in a special antistatic protective case.

Getting Started

UniOP panels must be programmed with the programming package Designer. To program a panel you will have to connect the panel to a personal computer running Designer software package; the panel must be in Configuration mode to be programmed. Use the cable CA2/CA114 to connect the panel to a personal computer.

The software package Designer is a Windows™ application and must be properly installed. The Windows™ environment is not included in the software package Designer and must already be installed on the personal computer.

The software package can use either the communication ports COM1 or COM2 on the personal computer. Check that the Designer program is correctly configured to communicate with the communication port to which the cable attached.

The communication parameters between the panel and the personal computer are:

speed: 9600 (models PC/Printer Port support also speeds of
19200 and 38400 baud)

parity: none

stop bit: 1

The Designer software defaults to the correct parameters.

The version of the Designer being used must be compatible with the firmware version of the panel to be programmed. Call for more information on compatibility between firmware and programming software.

Command Summary

The chapter describes the keyboard commands recognized by UniOP panels. Commands are classified according to the operating modes of the unit.

Note: The standard command assignment is described in this chapter. All the commands, except those defined for Configuration Mode, can be changed, deleted and/or extended using the Keyboard Macro Editor facility of the programming software.

Some models do not have CLEAR key on the keyboard; the corresponding function can be done pressing the keys $\leftarrow e \rightarrow$ at the same time.

Some models are designed to be attached to an external keyboard of type ET-F or AT-F; the commands described in this chapter are generally referring to the use of an external keyboard

All the UniOP models, except the ECT-16, ELT-16, ERT-16 and ECT-VGA, have at least 4 arrow keys and the Enter key. Panels with touch screen will show system defined touch keys on the screen whenever it is required (Figure 53).

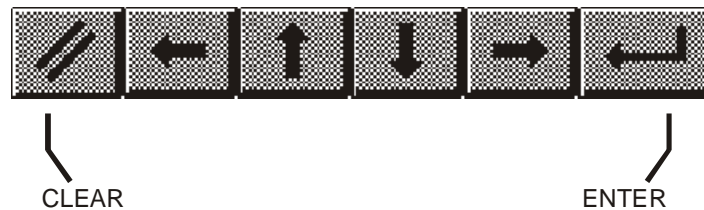


Figure 53 - Default touch keys for the panels with touchscreen

Some of the keys described in this chapter may not be available in each UniOP model. The functions associated to them may, however, be implemented using the Keyboard Macro Editor or using an alternative predefined key.

Models without numeric keypad and without touch screen allow numeric data entry using arrow keys and/or using the Keyboard Macro Editor.

Touch screen panels will show automatically a numeric keypad whenever the data entry phase is activated.



Note: the text '2 s' associated to a key means that the key has to be held for two seconds to activate the associated function.

UniOP

Configuration Mode

ENTER	shows the type and version of the communication driver stored in the unit (if any)
ENTER 2 s	returns to Operation Mode if a valid communication driver and a valid project are stored in the unit (the key must be pressed for 2 seconds)

Operation Mode

↑	scroll page up
↓	scroll page down
←	previous page
→	next page
ENTER 2 s	recall the Command Menu
0/INS	enter Data Entry Mode
Ins	enter Data Entry Mode
9/PRN	print page/cancel print
Prt Scr	print page/cancel print
ENABLE 2 s	recall Direct Access Mode
6/  (2)	recall Password Insert Mode
3/  (2)	recall Date/Time Insert Mode

To recall the Configuration Mode in the models ECT-16 , ELT-16 , ERT-16 and ECT-VGA touch the screen in an area where no touch cells have been defined and hold for 2 seconds.

Command Menu

↑	select up
↓	select down
←	select left
→	select right
ENTER	activate selection
CLEAR ⁽¹⁾	return to Page Mode

System Menu

↑	select up
↓	select down
←	activate selection
→	activate selection
ENTER	return to Page Mode when EXT is selected
CLEAR ⁽¹⁾	return to Page Mode

Data Entry Mode

When in Data Entry Mode the meaning of the keys changes depending on whether a field has been selected for Data Entry or not. A field is selected when The Data Entry procedure has been started on that field. If not field has already been selected for Data Entry, the key assignment is shown in the table below.

↑	move to field in previous row
↓	move to field in next row
←	previous field
→	next field
Ins	next field
0÷9 . +/-	select field a numeric field for Data Entry and enter numeric value
ENTER	select a field for Data Entry
CLEAR ⁽¹⁾	cancel entry and return to Page Mode

After a field has been selected for Data Entry, the keys are interpreted as follows.

↑	increment digit / scroll up ASCII / select message up
↓	increment digit / scroll down ASCII / select message down
←	move cursor left in ASCII field
→	move cursor right in ASCII field
0÷9 . +/-	numeric entry
ENTER	confirm entry and return to Page Mode
CLEAR ⁽¹⁾	cancel entry and return to Page Mode

Alarm Mode

↑	previous alarm in the list
↓	next alarm in the list
ENTER 2 s	acknowledge current alarm
CLEAR ⁽¹⁾	return to page Mode
9/PRN	alarm list printout/cancel print
Prt Alm	alarm list printout/cancel print
Prt Scr	alarm list printout/cancel print

Event Mode

↑	scroll up
↓	scroll down
CLEAR ⁽¹⁾	return to page Mode
9/PRN	event list printout/cancel print
Prt Alm	event list printout/cancel print
Prt Scr	event list printout/cancel print

Password Entry Mode

↑	increment digit
↓	decrement digit
←	next digit
0÷9	numeric password entry
ENTER	confirm password and return to Page Mode
CLEAR ⁽¹⁾	cancel entry and return to Page Mode
ESC	end entry and return to Page Mode

Time and Date Set Mode

↑	increment field value
↓	decrement field value
ENTER	field select
CLEAR ⁽¹⁾	return to Page Mode


Direct Page Selection Mode

←	decrement page
→	increment page
0÷9	page number entry
ENTER	confirm entry and go to selected page
CLEAR ⁽¹⁾	cancel entry and return to Page Mode

Direct Acces Mode

←	decrement offset
→	increment offset
0÷9	numeric offset entry
ENTER	select next, confirm offset entry
CLEAR ⁽¹⁾	cancel numeric offset entry end return to Page Mode
T	select timers
Z	select counters
E	select digital inputs
A	select digital outputs
M	select flags/merkers
ENABLE	return to Page Mode

Notes:

- (1) it is equivalent to the key ESC/  , when available
- (2) available only in the models BKDx-16, CP10G-04, CP12G-04, MKDG-06, MKDG-07, MKDx-25 and MKDC-VGA.

Troubleshooting

In the case it might be impossible to switch the operator panel to Configuration Mode due to problems in the start-up phase, follow the procedure described below:

1. Switch off the unit
2. Press and hold any 3 keys
3. Turn on the unit and hold the keys pressed until Configuration Mode will be shown on the screen.

For keyless models such as the ECT-16, ELT-16, ERT-16, follow the procedure below:

1. Switch off the unit
2. Touch in the middle of the left side of the display screen with the left hand
3. Switch on the operator panel and tap with the right hand in the middle of the right side of the display screen with a period of about one second.
4. Continue until the screen will show Configuration Mode

Touchscreen Calibration

Standard calibration:

1. Recall Configuration Mode
2. Touch the CLEAR key on the screen until a small round symbol will appear on the top right corner of the screen
3. touch and hold the symbol until it will move to the low left corner of the screen
4. touch and hold the symbol until the indication to touch the ← key will be displayed on the screen
5. touch and hold the key ← until the indication to touch the ↓ key will be displayed on the screen
6. touch and hold the key ↓ until the indication to touch the Enter key will be displayed on the screen
7. touch and hold the Enter key until the panel will switch to Operation Mode (if a valid project is loaded in the memory)

Emergency calibration.

The Emergency calibration procedure should be used in all cases when it would result not possible to go to calibration using the standard procedure.

1. Switch of the unit
2. turn on the unit
3. tap in the middle of the touchscreen with a frequency of about one second until the operator panel will enter the Calibration Mode
4. perform the standard calibration procedure.



SCATTERGOOD & JOHNSON LTD

ELECTRICAL ENGINEERING & FLUID CONTROL DISTRIBUTORS

Est.1899

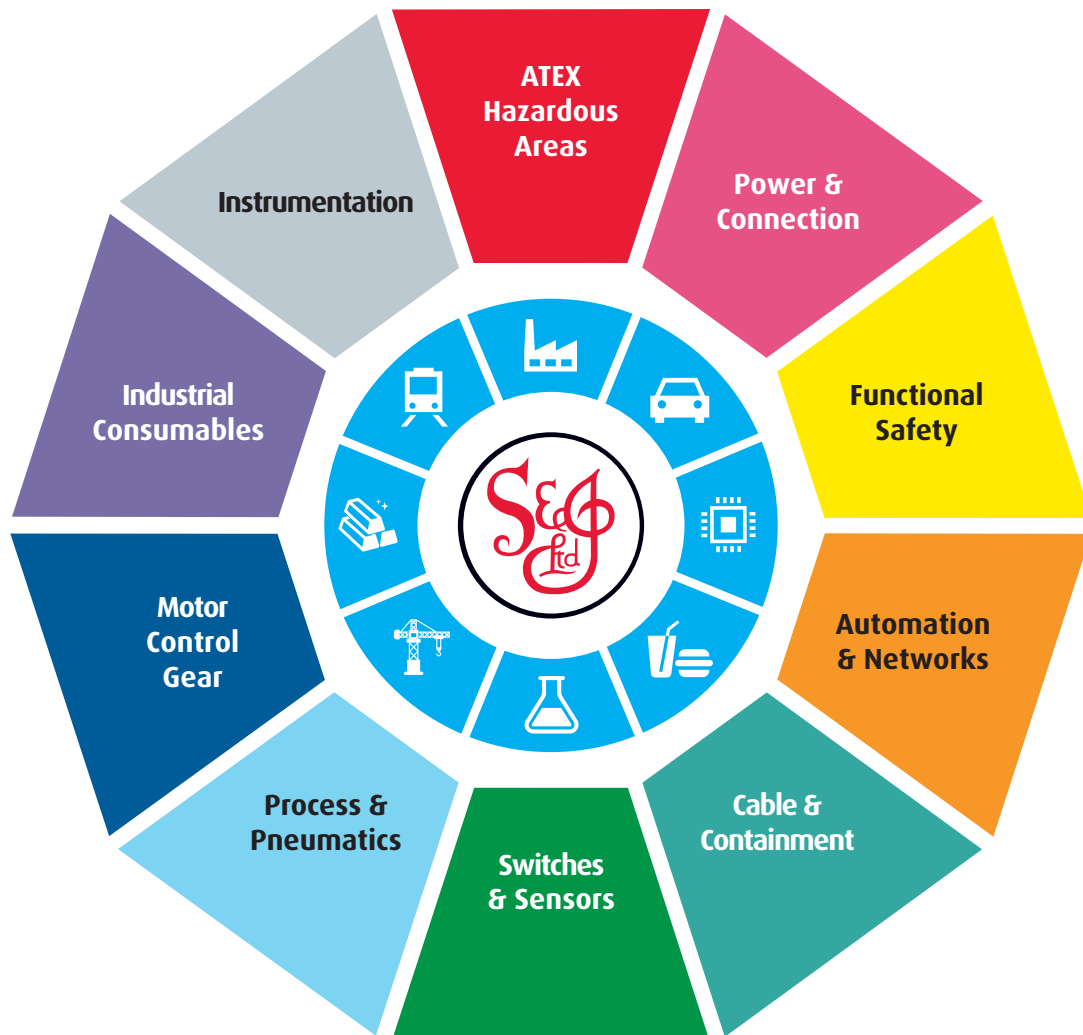
At Scattergood & Johnson Ltd, we pride ourselves on being a technical distributor to specialist industries.

Working with a range of quality product suppliers across a number of specialist markets, we are not your average 'box shifter' - we are your technical and supply chain partner.

We fully support every product we sell - for free! Our internal team and external sales engineers can answer any product or application question, no matter the complexity.

Backing up this technical ability is a range of 50,000+ products available from stock for nationwide next day delivery (same day if required!), or you can collect what you need from any of our trade counters around the UK.

Select your specialist interest below to learn more about how we can help.



Online, In Branch and On the Road - Scattergood & Johnson Ltd, there when you need us.

www.scatts.co.uk