

eTOP Series 500

Operating Instructions



Copyright © 2018 Exor International S.p.A. – Verona, Italy
Subject to change without notice

The information contained in this document is provided for informational purposes only. While efforts were made to verify the accuracy of the information contained in this documentation, it is provided "as is" without warranty of any kind.

Third-party brands and names are the property of their respective owners.

www.exorint.com



Table of Contents

Introduction	4
Safety guide	5
1 Product overview	6
2 Standards and approvals	7
3 Technical specifications	8
4 Technical data	10
4.1 Dimensions	14
4.2 Installation environment	16
4.3 Installation procedure	17
5 Connections	18
5.1 Serial port	20
5.2 Ethernet port	21
5.3 Option plugin module	22
6 Power supply, grounding and shielding	24
7 Battery	25
8 Cleaning faceplates	26
9 Getting started	26
10 System settings	27
11 LED indicator on front panel	30
12 Unpacking and packing Instructions	31



Introduction

The operational guidelines described below is information which relates to the device, installation, transportation, storage, assembly, use and maintenance.

This Operating Instruction describes the main features of the operator panels. The Guide refers to the following models:

eTOP504	Operator interface with TFT color 4,3" display touchscreen
eTOP506	Operator interface with TFT color 5.7" display touchscreen
eTOP507	Operator interface with TFT color 7" widescreen display touchscreen
eTOP507M	Operator interface with TFT color 7" widescreen display touchscreen, 1GHz CPU
eTOP510	Operator interface with TFT color 10.4" display touchscreen
eTOP512	Operator interface with TFT color 12.1" display touchscreen
eTOP513	Operator interface with TFT color 13.3" widescreen display touchscreen
eTOP515	Operator interface with TFT color 15" display touchscreen



Safety Guide

The manual contains safety standards that must be respected for the personal safety and to avoid damage. Indications of attention are divided into three levels of severity:

DANGER: indicates a failure to observe safety rules and such failure may cause death or serious injuries.



DANGER

ATTENTION: indicates a failure to observe safety rules and that deficiency may cause damage.



ATTENTION

CAUTION: indicates a failure to observe safety rules and that deficiency may cause defects to the equipment or inconsistencies.



CAUTION



1 Production Overview

The Exor eTOP Series 500 HMI products combine state-of-the-art features and top performance with an outstanding design. They are the ideal choice for all demanding HMI applications including factory and building automation.

The eTOP Series 500 HMI panels have been designed to run the JMobile software.

- Designed for use with JMobile HMI software.
- Full vector graphic support. Native support of SVG graphic objects. Transparency and alpha blending.
- Full object dynamics: control visibility and transparency, move, resize, rotate any object on screen. Change properties of basic and complex objects.
- TrueType fonts.
- Multilanguage applications. Easily create and manage your applications in multiple languages to meet global requirements. Far East languages are supported. Tools available in JMobile Studio support easy third-party translations and help reducing development and maintenance costs of the application.
- Data display in numerical, text, bargraph, analog gauges and graphic image formats.
- Rich set of state-of-the-art HMI features: data acquisition, alarm handling, scheduler and timed actions (daily and weekly schedulers, exception dates), recipes, users and passwords, RSS feeds, rotating menus.
- Includes support for a wide range of communication drivers for Factory systems.
- Multiple drivers communication capability.
- Remote monitoring and control. Client-Server functionality.
- On-line and Off-line simulation with JMobile Studio.
- Powerful scripting language for automating HMI applications. Script debugging improves efficiency in application development.
- Rich gallery of vector symbols and objects.
- Optional plug-in modules for fieldbus systems, I/O and controllers.



2 Standards and Approvals

The products have been designed for use in an industrial environment in compliance with the 2014/30/EU EMC Directive.

The products have been designed in compliance with:

EN 61000-6-4 EN 55011 Class A

EN 61000-6-2 EN 61000-4-2
 EN 61000-4-3
 EN 61000-4-4
 EN 61000-4-5
 EN 61000-4-6

The installation of these devices into the residential, commercial and light-industrial environments is allowed only in the case that special measures are taken in order to ensure conformity to EN 61000-6-3.

The products are in compliance with the Restrictions on Certain Hazardous Substances (RoHS) Directive 2011/65/EU

In compliance with the above regulations the products are CE marked.

Product Identification

The product may be identified through a plate attached to the rear cover. You will have to know the type of unit you are using for correct usage of the information contained in the guide.

An example of this plate is shown in the figure below:



eTOP504
ETOP504U1P1
1846
AA00001HP123456789AA
040100A15011000

product model name
product part number
year/week of production
serial number
version id of the product



3 Technical Specifications

Touch screen technology	Resistive
Back-up battery	3V 50mAh Lithium, rechargeable, not user-replaceable, model VL2330.
Fuse	Automatic
Serial Port	RS-232, RS-485, RS-422 software configurable
User memory	Flash 128MB for eTOP504, 506, 507 Flash 256MB for eTOP507M, eTOP510, 512, 513, 515
Recipe memory	Flash
Hardware clock	Clock/Calendar with back-up battery
Accuracy RTC (at 25°C operating)	<100ppm

Environmental conditions

Operating temperature (vertical installation)	0 ÷ +50°C	EN 60068-2-14
Storage temperature	-20 ÷ +70°C	EN 60068-2-14
Operating and storage humidity	5 ÷ 85 % RH not-condensing	EN 60068-2-30
Vibrations	5 ÷ 9 Hz, 7 mm _{p-p} 9 ÷ 150 Hz, 1 g	EN 60068-2-6
Shock	± 50 g, 11 ms, 3 pulses per axis	EN 60068-2-27
Protection class	IP66 front panel *	EN 60529

* The front face of the unit, installed in a solid panel, has been tested using conditions equivalent to the standards shown in the "Environmental conditions". Even though the level of resistance unit is equivalent to these standards, oils that should have no effect on the panel can possibly harm the unit. This can occur in areas where either vaporized oils are present, or where low viscosity cutting oil are allowed to adhere to the unit for long periods of time. If the front face protection sheet on the panel becomes peeled off, these conditions can lead to the ingress of oil into the panel and separate protection measures are suggested.

If the installation gasket is used for a long period of time, or if the unit and its gasket are removed from the panel, the original level of the protection cannot be guaranteed.

Electromagnetic Compatibility (EMC)

Radiated disturbance test	Class A	EN 55011
Electrostatic discharge immunity test	8 kV (air electrostatic discharge) 4 kV (contact electrostatic discharge)	EN 61000-4-2
Radiated, radio-frequency, electromagnetic field immunity test	80 MHz ÷ 1 GHz, 10V/m 1,4 GHz ÷ 2 GHz, 3 V/m 2 GHz ÷ 2.7 GHz, 1 V/m	EN 61000-4-3



3 Technical Specifications

Burst immunity test	± 2 KV DC power port ± 1 KV signal line	EN 61000-4-4
Surge immunity test	± 0,5 KV DC power port (line to earth) ± 0,5 KV DC power port (line to line) ± 1 KV signal line (line to earth)	EN 61000-4-5
Immunity to conducted disturbances induced by radiofrequency field	0.15 ÷ 80 MHz, 10V	EN 61000-4-6
Voltage dips, short interruptions and voltage variations immunity test	Port: AC mains; Level: 100% duration: 1 cycle and 250 cycles (50Hz); 40% duration: 10 cycles (50Hz); 70% duration: 25 cycles (50Hz); Phase: 0°-180°	
Test executed on the 230Vac side of the Exor International Power Supply		EN 61000-4-11

Durability information

Backlight service life (LED type)	40000 Hrs. or more (Time of continuous operation until the brightness of the backlight reaches 50% of the rated value when the surrounding air temperature is 25°C) - see Note 1
Front foil (without directly exposure to sunlight or UV ray)	10 years if the surrounding air temperature is 25°C
UV Resistance	Indoor applications: After 300 hours cycled humidity in QUV accelerated weathering, some yellowing and brittleness may be present. - see Note 2.
Touch screen reliability	> 1 milion operations

Note 1: Extended use in environments where the surrounding air temperature is 40°C or higher may degrade backlight quality/reliability/durability.

Note 2: Solvent resistance:

Contact for 1/2 hour at 21°C, No visible effect: Acetone, Butyl Cellosolve, Cyclohexanone, Ethyl Acetate, Hexane, Isopropyl Alcohol, MEK, Methylene Chloride, Toluene, Xylene

Contact for 24 hours at 49°C, No visible effect: Coffee, Ketchup, Lemon Juice, Mustard (slight yellow stain), Tea, Tomato juice.



4 Technical Data

Model	eTOP504	eTOP506
Display / Backlight	TFT Color / LED	TFT Color / LED
Colors	64K	64K
Resolution	480x272	320x240
Diagonal (inches)	4.3"	5.7"
Dimming	yes	yes
User memory Flash	128 MB	128 MB
SD card slot	yes	yes
Recipe memory	Yes. Flash memory storage limited only by available memory	Yes. Flash memory storage limited only by available memory
Serial Port	RS-232, RS-485, RS-422 DB9 female software configurable	RS-232, RS-485, RS-422 DB9 female software configurable
Ethernet port	2 10/100 Mbit with integrated switch	2 10/100 Mbit with integrated switch
USB port	1 Host interface version 2.0 and version 1.1	2 Host interface, 1 version 2.0, 1 version 2.0 and 1.1
Expansion slot	1 Optional Plugin	2 Optional Plugin
Battery	rechargeable	rechargeable
Real Time Clock	yes	yes
Voltage	18-32VDC (*)	18-32VDC (*)
Current rating (at 24VDC)	0.4A	0.65A
Weight	1 Kg	1 Kg

(*) For applications requiring compliance with EN 61131-2 and specifically in reference to 10 ms voltage dips, the minimum power supply voltage is 18Vdc,



4 Technical Data

Model	eTOP507	eTOP507M
Display / Backlight	TFT Color / LED	TFT Color / LED
Colors	64K	64K
Resolution	800x480	800x480
Diagonal (inches)	7" widescreen	7" widescreen
Dimming	yes	yes
User memory Flash	128 MB	256 MB
SD card slot	yes	yes
Recipe memory	Yes. Flash memory storage limited only by available memory	Yes. Flash memory storage limited only by available memory
Serial Port	RS-232, RS-485, RS-422 DB9 female software configurable	RS-232, RS-485, RS-422 DB9 female software configurable
Ethernet port	2 10/100 Mbit with integrated switch	2 10/100 Mbit with integrated switch
USB port	2 Host interface, 1 version 2.0, 1 version 2.0 and 1.1	2 Host interface, 1 version 2.0, 1 version 2.0 and 1.1
Expansion slot	2 Optional Plugin	2 Optional Plugin
Battery	rechargeable	rechargeable
Real Time Clock	yes	yes
Voltage	18-32VDC (*)	18-32VDC (*)
Current rating (at 24VDC)	0.65A	0.7A
Weight	1 Kg	1 Kg

(*) For applications requiring compliance with EN 61131-2 and specifically in reference to 10 ms voltage dips, the minimum power supply voltage is 18Vdc,



4 Technical Data

Model	eTOP510	eTOP512
Display / Backlight	TFT Color / LED	TFT Color / LED
Colors	64K	64K
Resolution	800x600	800x600
Diagonal (inches)	10.4"	12.1"
Dimming	yes	yes
User memory Flash	256 MB	256 MB
SD card slot	yes	yes
Recipe memory	Yes. Flash memory storage limited only by available memory	Yes. Flash memory storage limited only by available memory
Serial Port	RS-232, RS-485, RS-422 DB9 female software configurable	RS-232, RS-485, RS-422 DB9 female software configurable
Ethernet port	2 10/100 Mbit with integrated switch	2 10/100 Mbit with integrated switch
USB port	2 Host interface, 1 version 2.0, 1 version 2.0 and 1.1	2 Host interface, 1 version 2.0, 1 version 2.0 and 1.1
Expansion slot	2 Optional Plugin	2 Optional Plugin
Battery	rechargeable	rechargeable
Real Time Clock	yes	yes
Voltage	18-32VDC (*)	18-32VDC (*)
Current rating (at 24VDC)	1A	1.2A
Weight	2.1 Kg	2.8 Kg

(*) For applications requiring compliance with EN 61131-2 and specifically in reference to 10 ms voltage dips, the minimum power supply voltage is 18Vdc,



4 Technical Data

Model	eTOP513	eTOP515
Display / Backlight	TFT Color / LED	TFT Color / LED
Colors	64K	64K
Resolution	1280x800	1024x768
Diagonal (inches)	13.3" widescreen	15"
Dimming	yes	yes
User memory Flash	256 MB	256 MB
SD card slot	yes	yes
Recipe memory	Yes. Flash memory storage limited only by available memory	Yes. Flash memory storage limited only by available memory
Serial Port	RS-232, RS-485, RS-422 DB9 female software configurable	RS-232, RS-485, RS-422 DB9 female software configurable
Ethernet port	2 10/100 Mbit with integrated switch	2 10/100 Mbit with integrated switch
USB port	2 Host interface, 1 version 2.0, 1 version 2.0 and 1.1	2 Host interface, 1 version 2.0, 1 version 2.0 and 1.1
Expansion slot	2 Optional Plugin	2 Optional Plugin
Battery	rechargeable	rechargeable
Real Time Clock	yes	yes
Voltage	18-32VDC (*)	18-32VDC (*)
Current rating (at 24VDC)	1.2A	1.4A
Weight	2.8 Kg	3.5 Kg

(*) For applications requiring compliance with EN 61131-2 and specifically in reference to 10 ms voltage dips, the minimum power supply voltage is 18Vdc,



4 Technical Data

4.1 Dimensions

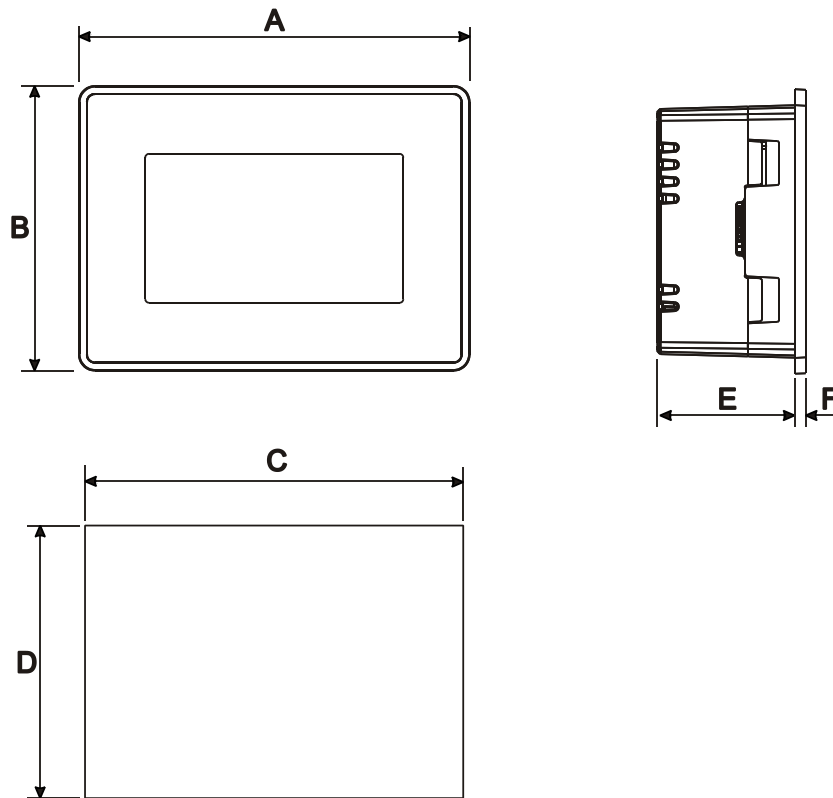

MODEL	A	B	C	D	E	F
eTOP504	149mm/5.86"	109mm/4.29"	136mm/5.35"	96mm/3.78"	56mm/2.40"	4mm/0.16"



4 Technical Data

4.1 Dimensions

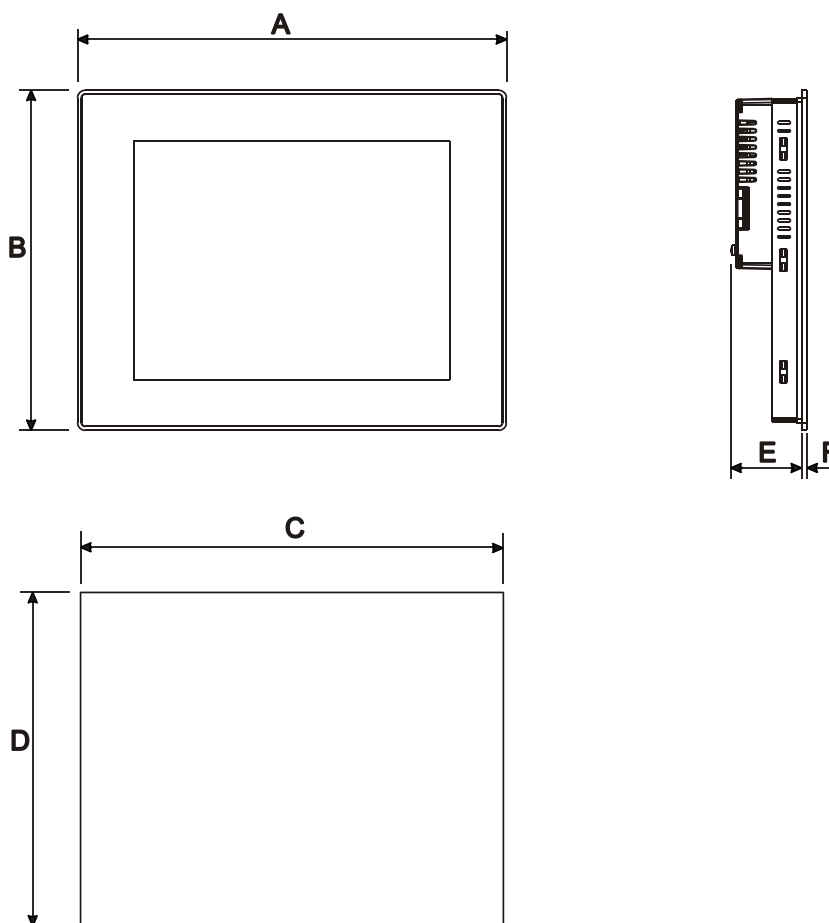

MODEL	A	B	C	D	E	F
eTOP506	187mm/7.36"	147mm/5.79"	176mm/6.90"	136mm/5.35"	47mm/1.85"	4mm/0.16"
eTOP507	187mm/7.36"	147mm/5.79"	176mm/6.90"	136mm/5.35"	47mm/1.85"	4mm/0.16"
eTOP507M	187mm/7.36"	147mm/5.79"	176mm/6.90"	136mm/5.35"	47mm/1.82"	4mm/0.16"
eTOP510	287mm/11.30"	232mm/9.13"	276mm/10.86"	221mm/8.70"	56mm/2.20"	4mm/0.16"
eTOP512	336mm/13.22"	267mm/10.51"	326mm/12.83"	256mm/10.07"	56mm/2.20"	4mm/0.16"
eTOP513	336mm/13.22"	267mm/10.51"	326mm/12.83"	256mm/10.07"	56mm/2.20"	4mm/0.16"
eTOP515	392mm/15.43"	307mm/12.08"	381mm/15"	296mm/11.65"	60mm/2.36"	4mm/0.16"



4 Technical Data

4.2 Installation Environment

The equipment is not intended for continuous exposure to direct sunlight. This might accelerate the aging process of the front panel film.

The equipment is not intended for installation in contact with corrosive chemical compounds. Check the resistance of the front panel film to a specific compound before installation.

Do not use tools of any kind (screwdrivers, etc.) to operate the keyboard of the panel or the touch screen.

In order to meet the front panel protection classifications, proper installation procedure must be followed:

- the borders of the cutout must be flat
- screw up each fixing screw until the plastic bezel corner get in contact with the panel.
- the cutout for the panel must be of the dimensions indicated in this manual.

The IP66 is guaranteed only if:

- max deviation from the plane surface to the cut-out: $\leq 0.5\text{mm}$
- thickness of the case where is mounted the equipment: from 1,5mm to 6mm
- max surface roughness where the gasket is applied: $\leq 120\ \mu\text{m}$

Applying the rectangular gasket

The gasket should be applied on the rear of the frame.

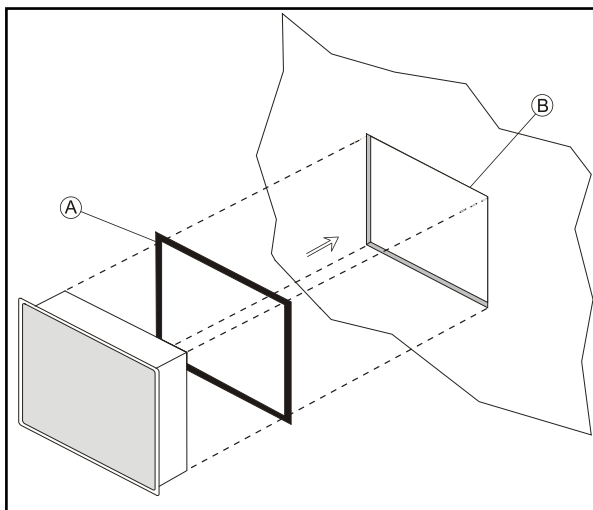

**Fig. 4.1: eTOP504, eTOP506,
eTOP507, eTOP507M**

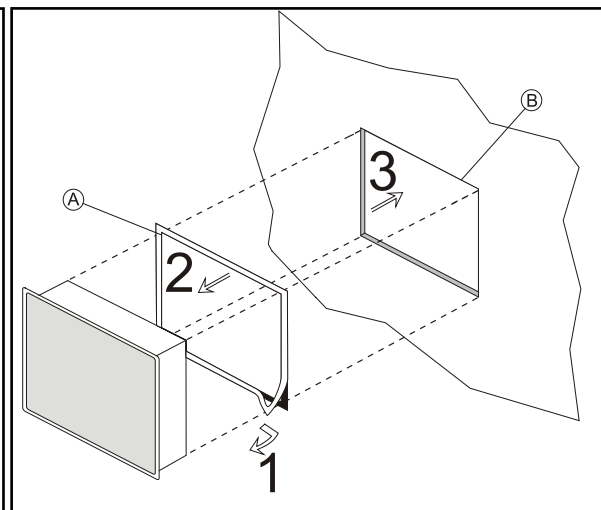

**Fig. 4.2: eTOP510, eTOP512,
eTOP513, eTOP515**

A. Gasket

B. Installation cut-out



4 Technical Data

4.3 Installation Procedure

Place the fixing brackets as shown in figure (Fig. 4.3).

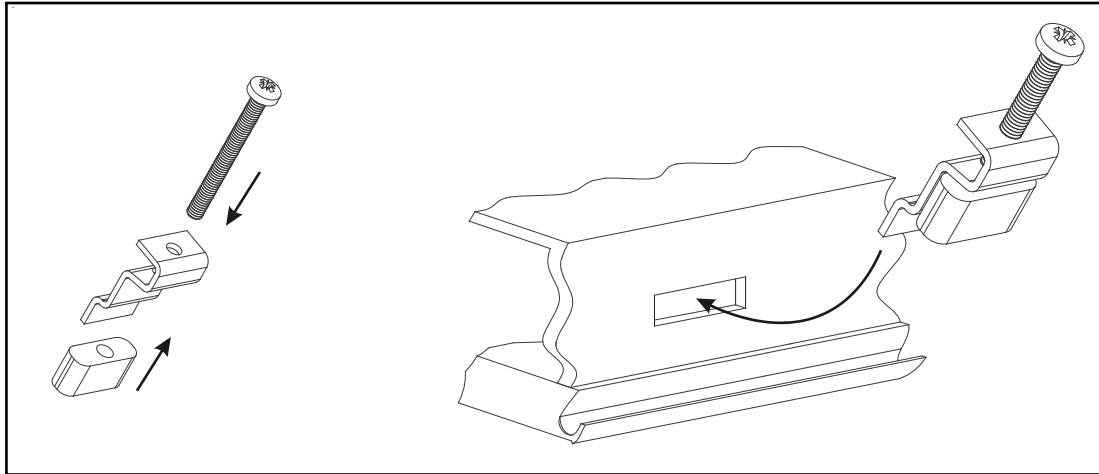

Fig. 4.3



CAUTION

Screw each fixing screw until the bezel corner gets in contact with the panel



5 Connections

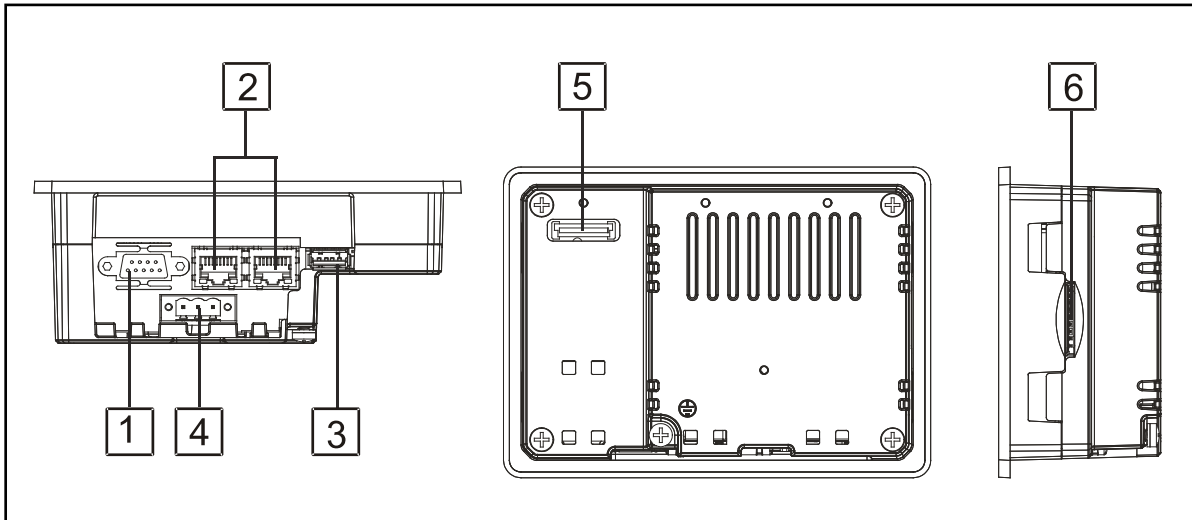

Fig. 5.1 - eTOP504

1. Serial Port
2. 2x Ethernet Port
3. USB Port
4. Power Supply
5. Expansion slot for Plugin module
6. SD Card Slot



5 Connections

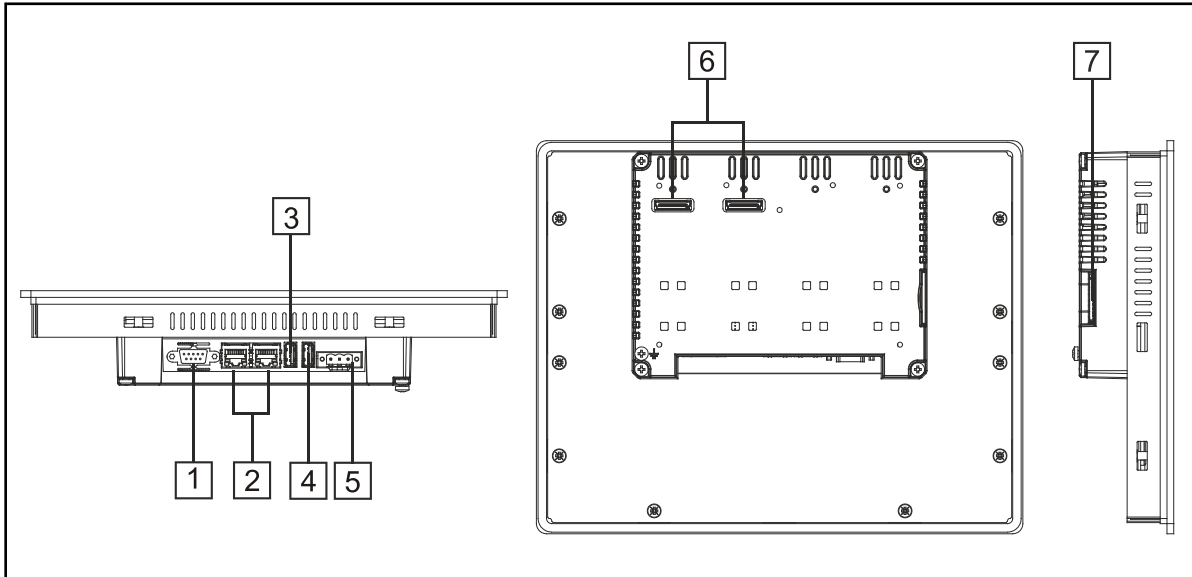

Fig. 5.2 - eTOP5xx

1. Serial Port
2. 2x Ethernet Port
3. USB Port (version 2.0 - 1.1)
4. USB Port (version 2.0 High speed only)
5. Power Supply
6. 2x Expansion slot for Plugin module
7. SD Card Slot



5 Connections

5.1 Serial Port

The serial port is used to communicate with the PLC or with another type of controller. Different electrical standards are available for the signals in the PLC port connector: RS-232, RS-422, RS-485.

The serial port is software programmable. Make sure you select the appropriate interface in the programming software.

RS-232

Pin	Description
1	GND
2	
3	TX
4	RX
5	
6	+5V output
7	CTS
8	RTS
9	

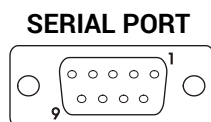

RS-422, RS-485

Pin	Description
1	GND
2	
3	CHA-
4	CHB-
5	
6	+5V output
7	CHB+
8	CHA+
9	

The communication cable must be chosen for the type of device being connected.



5 Connections

5.2 Ethernet Port

The Ethernet port have two status indicators. Please see description in figure.

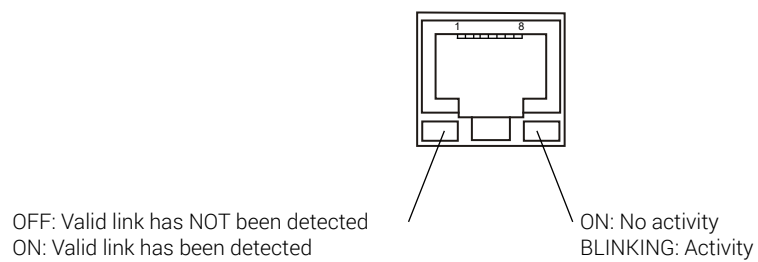



5 Connections

5.3 Optional plugin module

eTOP500 serie panels have several optional plugin module, multiple modules configurations are possible.

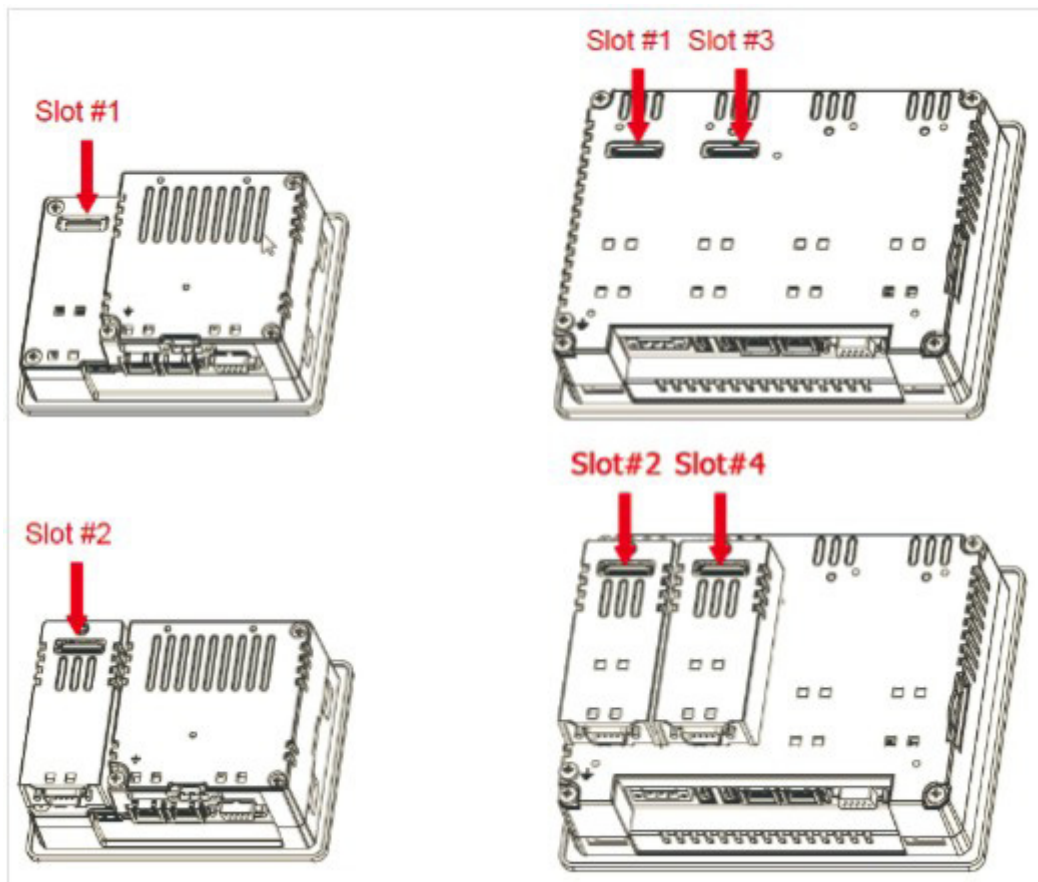

Slot#2 and Slot#4 are available only if plugin module has the “bus extension connector”.

Each slot carries three communication channels:

- 1 serial interface
- 1 CAN interface
- 1 SPI interface

Note: It is not possible to stack two modules that are using the same type of interface.



5 Connections

Below you can find relation between modules and max number of modules that can be used into eTOP500 serie panels, based on their Interface Type:

Module	Application	Max Modules	Interface Type	Bus Extension connector
PLCM01	CAN	1 for eTOP50x 2 for eTOP51x	CAN	Y
PLCM01-NE	CAN	1 for eTOP50x 2 for eTOP51x	CAN	N
PLCM02	KNX	1	Serial	N
PLCM03	Serial RS232	2	Serial	Y
PLCM04	Serial RS485	2	Serial	Y
PLCM05	CODESYS V2 License	1		Y
PLCM06	Profibus DP	1	SPI	N
PLIO03	Multifunction I/O	1	SPI	N
PLIO06	Compact I/O	2	SPI	N

Max modules refers to max number of modules can be plugged into the HMI (all slots),

If you are planning to use PLCM03 and PLCM04 (additional serial ports) you will obtain following "COM - Slot#" association:

- a module plugged in Slot#1 or into Slot#2 will be COM2,
- a module plugged in Slot#3 or into Slot#4 will be COM3.

If you are planning to use two PLCM01 (CAN interface) you will obtain following Slot# association:

- a module plugged in Slot#1 or into Slot#2 will be the CanPort 0,
- a module plugged in Slot#3 or into Slot#4 will be the CanPort 1.



6 Power Supply, Grounding and Shielding

The power supply terminal block is shown in the figure below.

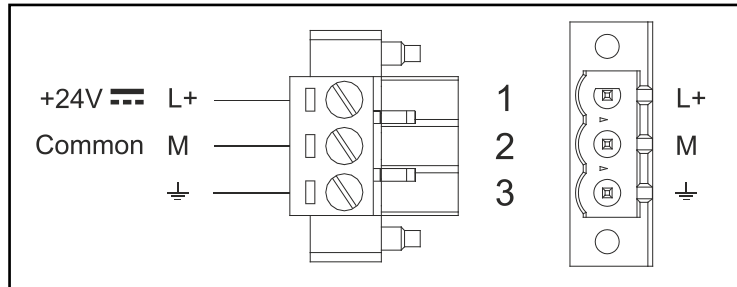

Fig. 6.1 - Power supply terminal block

Note: *Ensure that the power supply has enough power capacity for the operation of the equipment.*

The unit must always be grounded to earth. Grounding helps limit the effects of noise due to electromagnetic interference on the control system.

Earth connection will have to be done using either the screw or the faston terminal located near the power supply terminal block. A label helps identify the ground connection. Also connect to ground the terminal 3 on the power supply terminal block.

The power supply circuit may be floating or grounded. In the latter case, connect to ground the power source common as shown in figure (see below) with a dashed line.

When using the floating power scheme, note that the panel internally connects the power common to ground with a 1M Ω resistor in parallel with a 4,7nF capacitor.

The power supply must have double or reinforced insulation.

The suggested wiring for the power supply is shown below.

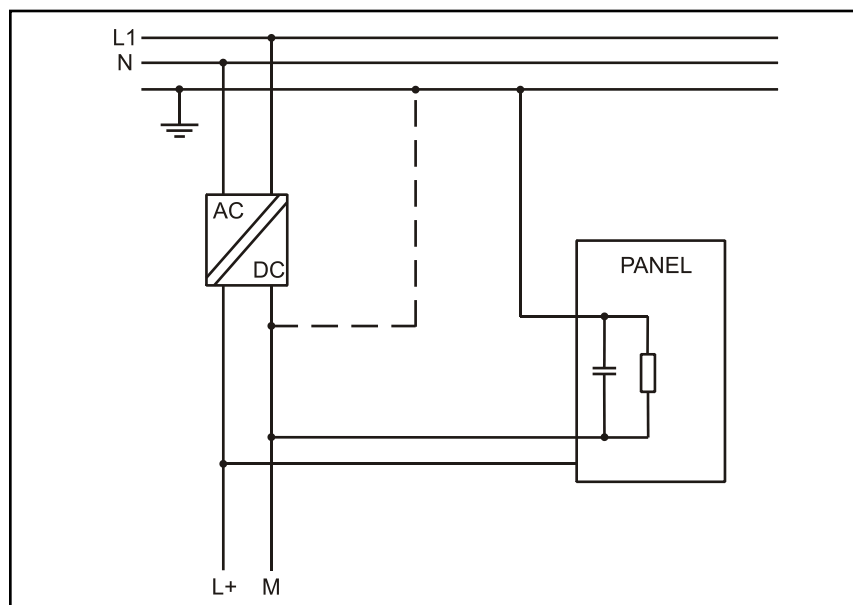

Fig. 6.2

All the electronic devices in the control system must be properly grounded. Grounding must be performed according to applicable regulations.



7 Battery

These devices are equipped with rechargeable Lithium battery, not user-replaceable.

The following information is maintained by the battery:

- hardware real-time clock (date and time)

Charge:

At first installation must be charged for 48 hours.

When the battery is fully charged, it ensures a period of 3 months of data back-up at 25°C.

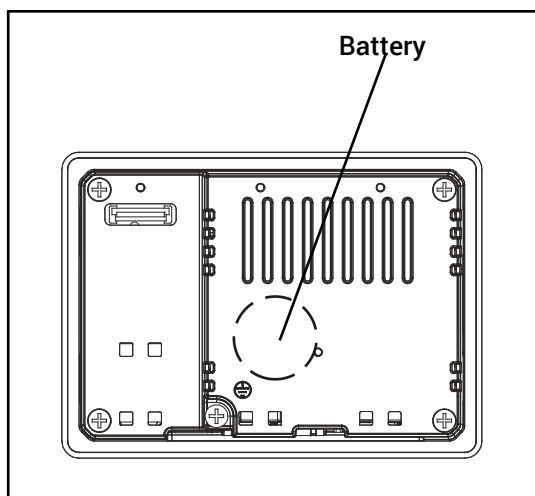

Fig. 7.1: eTOP504

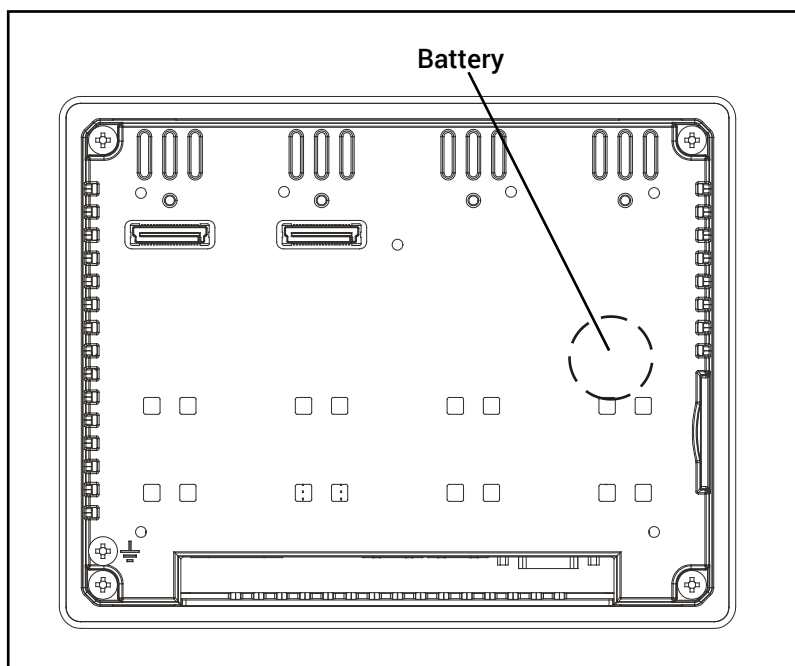

Fig. 7.2: eTOP506, eTOP507, eTOP507M, eTOP510, eTOP512, eTOP513, eTOP515



ATTENTION

Dispose of batteries according to local regulations.





8 Cleaning faceplates

The equipment must be cleaned only with a soft cloth and neutral soap product. Do not use solvents.

9 Getting Started

eTOP Series 500 HMI products must be programmed with the software JMobile Studio. JMobile Studio is a software tool that must be properly installed on a computer running Microsoft Windows.

There are two options to transfer a JMobile application project to a HMI device:

- | | |
|-----------|--|
| Ethernet | Connect the HMI device to the computer with an Ethernet network connection. From JMobile Studio choose the command Run/Download to target. You may have to ensure that the proper firewall policy has been configured in the computer to allow JMobile Studio to access the network. |
| USB or SD | Create an Update Package using JMobile Studio and copy it to a USB Flash drive or to an SD memory card. |



10 System Settings

eTOP Series 500 HMI products have a system settings tool to allow configuration of system options. The user interface of System Settings tool is based on a rotating menu. Use navigation buttons Next/Back to scroll through the available options.

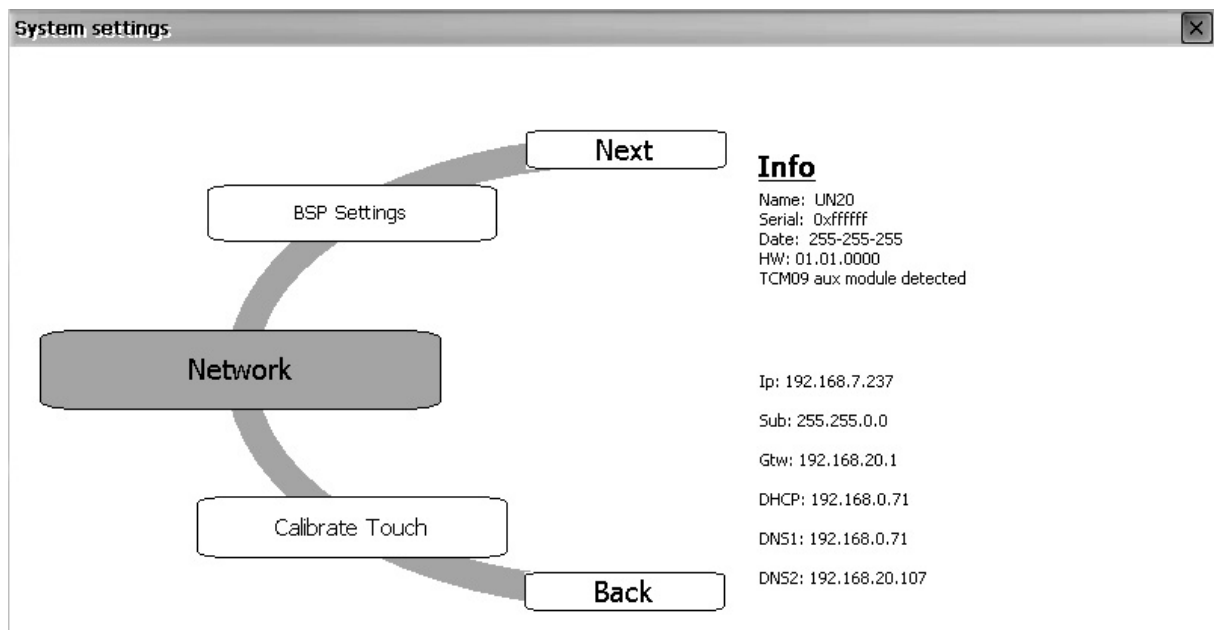

The active item is highlighted on the left side. The info pane on the right side shows relevant information, when applicable. Touch the active item to start the associated function.

System Settings has two modes of operation:

- User Mode** JMobile runtime is running or the HMI device is in "factory default" status.
- System Mode** JMobile runtime is not running or the HMI device has a software failure. System Mode includes all options available in User Mode and offers in additions commands dedicated to system upgrade and recovery.

Activation of System Settings in **User Mode**:

- | | |
|-------------------------|---|
| Factory default status | Press "System Setting" button on the HMI screen |
| JMobile runtime running | Recall context menu and select "System Settings". To recall the context menu click and hold any unused area of the touchscreen for a few seconds. Default hold time is 2 seconds. |



10 System Settings

Activation of Systems Settings **System Mode:**

Normal operation	<p>If JMobile runtime is not running: Press "System Settings" button on the HMI screen.</p> <p>If JMobile runtime is running: recall context menu, select "System Settings"</p> <p>Select the Restart option then choose the "Configuration OS" option.</p> <p>Note: To recall the context menu click and hold any unused area of the touchscreen for a few seconds. Default hold time is 2 seconds.</p>
Recovery operation	<p>If panel is not responsive, use the so-called "tap-tap" procedure. This procedure consists in tapping the surface of the touchscreen during the device power-up phase. Tapping frequency must be high. You have to start tapping the touchscreen as soon as power has been applied to the device. When the sequence has been recognized, the system shows the message: "Tap Tap detected, Going to Config Mode" on the screen.</p>

User Mode includes options for basic settings of the device.

Calibrate Touch	calibrate the touchscreen interface
Plugin list	show if optional plug-in modules are installed
Network	configure IP Address of Ethernet interface
BSP settings	show the BSP (Board Support Package) version, check the operating hours for the device and for the display backlight, manage the buzzer
Time	change the device date and time, including time zone, Daylight Saving Time and NTP Server
Regional Settings	customize Windows Regional Settings, such as date format
Display settings	configure automatic backlight turnoff and adjust brightness
Close	close System Settings
Restart	restart the device. "Main OS" option restarts as per default, "Configuration OS" option restart panel directly into System Settings in System Mode

System Mode is the complete interface of the System Settings tool where all functions are available, in addition to the options available in "User Mode".

Format Flash	allows to format internal device Flash disk. All projects, the Runtime and System settings will be deleted, returning the device to factory condition.
Restore Factory Settings	<p>restore factory settings with choice of what to delete. Can be used as alternative to Format Flash. Options available are:</p> <p><u>Uninstall HMI</u> removes the Runtime and all projects.</p> <p><u>Clear system settings</u> reset the system parameters like IP Address, date/time, etc</p> <p><u>Clear Controller Application</u> remove CODESYS application</p>



10 System Settings

Resize Image Area	reserved to authorized technical personnel
Download Configuration OS	update the Configuration OS module of BSP
Download Main OS	update the Main OS module of BSP
Download Splash Image	replace the splash screen image displayed by the device at power-up; the image must be supplied in the appropriate binary format. We recommend changing the splash screen image with the use of JMobile Studio
Download OS Partition	reserved to authorized technical personnel
Download Data Partition	reserved to authorized technical personnel
Download Disk Image	reserved to authorized technical personnel
Download Bootloader	update the Bootloader module of BSP
Upload Bootloader	reserved to authorized technical personnel
Upload Configuration OS	reserved to authorized technical personnel
Upload Main OS	reserved to authorized technical personnel
Upload Splash Image	copy to an USB Memory or SD Card the current splash screen image in binary format
Upload OS Partition	reserved to authorized technical personnel
Upload Data Partition	reserved to authorized technical personnel
Upload Disk-Image	copy to an USB Memory or SD Card the content of whole Flash disk in binary format

Only for eTOP507M, eTOP510, eTOP512, eTOP513 and eTOP515 System Mode includes also:

Download Main FPGA	update the Main FPGA module of BSP
Download Safe FPGA	update the Safe FPGA module of BSP
Download System Supervisor	update the System Supervisor module of BSP
Upload Main FPGA	reserved to authorized technical personnel
Upload Safe FPGA	reserved to authorized technical personnel
Upload System Supervisor	reserved to authorized technical personnel



11 LED Indicator on Front Panel

The table below shows the symbol of the LED indicator dedicated to special functions.

LED Indicator		Status	Meaning
Symbol	Color		
	red	ON	Hardware fault / Battery low
	green	ON	Normal operation
		BLINK	Communication error



12 Unpacking and packing instructions

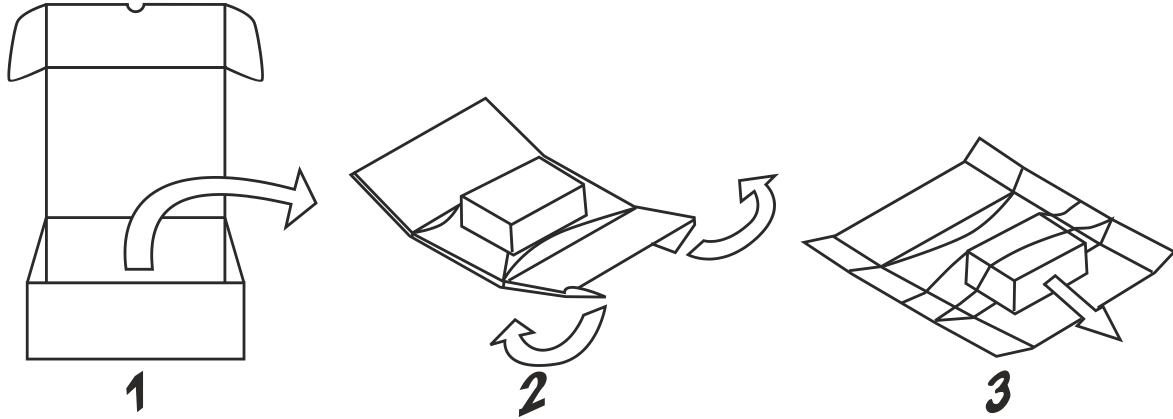

To repack the unit, please follow the instructions backwards.



SCATTERGOOD & JOHNSON LTD

ELECTRICAL ENGINEERING & FLUID CONTROL DISTRIBUTORS

Est.1899

At Scattergood & Johnson Ltd, we pride ourselves on being a technical distributor to specialist industries.

Working with a range of quality product suppliers across a number of specialist markets, we are not your average 'box shifter' - we are your technical and supply chain partner.

We fully support every product we sell - for free! Our internal team and external sales engineers can answer any product or application question, no matter the complexity.

Backing up this technical ability is a range of 50,000+ products available from stock for nationwide next day delivery (same day if required!), or you can collect what you need from any of our trade counters around the UK.

Select your specialist interest below to learn more about how we can help.

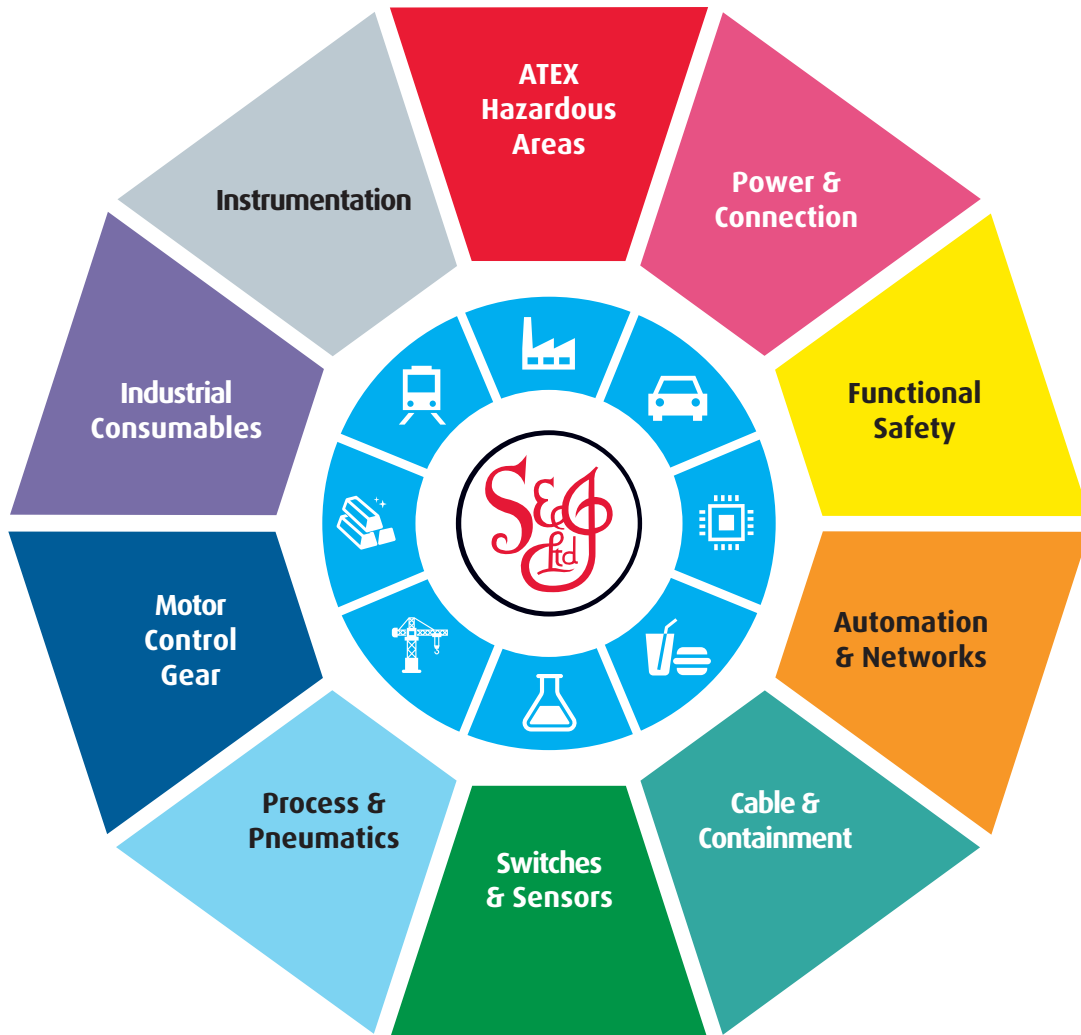

Online, In Branch and On the Road - Scattergood & Johnson Ltd, there when you need us.

www.scatts.co.uk