



## eX707FB Tech-Note

Where tough legislation requires that handling, preparation, processing and packaging of food is done to be extremely hygienic, the outstanding eX707FB 7" Food and Beverage HMI is the **best choice for manufacturer and final consumer**.

No other company offers such specialized solutions to the everyday problems faced in the Food and Beverage industry and in **particular the meat processing sector**.



- Extensive Guarantee despite no Protective Casing
- Ease of Cleaning
- Real World IP69 Rating
- High Pressure 80°C Water Resistant
- Perfect Stainless Steel Bezel Design
- Polyester Coating on front
- Acid Chemical Resistant
- Food Compliant Gasket
- Front panel and gasket guidelines:  
DIN EN1672-2  
EHEDG / FDA 21 CFR 177.2006

## Highlights

The food & beverage and pharmaceutical sectors are very different environments from the industrial world. Although the set up of the production facilities might seem similar, **there are a series of legislative requirements and guidelines that are dramatically more onerous**.

EXOR has adapted its highly successful eX707 to meet these challenges. EXOR alters the HMI devices in many areas to comply with the CEI EN 60529 guidelines with an **incredible level of attention to eliminating the accumulation of food, grease, and product powder particles**.

The rugged stainless-steel fronts are **highly polished to allow particles to flow away** from the surface. The frame has the optimal **angle of contact to the machine surface** to both enable cleaning liquids to wash away and also **not to allow bacteria or microbes to remain**.

All these measures and more mean that EXOR can offer this product at a high protection **front panel rating of IP69**: resistance to frequent washing with water at high pressure and high temperature. Resistance to highly aggressive cleaning substances is a plus.

No longer will you need to contain the HMI devices within a costly cabinet as is so often seen. Industry sectors that might require this series are the **food, pharmaceutical and chemical industries or anywhere, where the highest level of attention to hygiene is a requirement for reputational risk**.

# eX707FB - Technical Data



System Resources	
Display - Colors	7" TFT 16:9 LED - 16M
Resolution	800x480, WVGA
Brightness	500 Cd/m <sup>2</sup> typ.
Dimming	to 0%
Touchscreen	Projected Capacitive, Multitouch
CPU	ARM Cortex-A9 dual core 800 MHz
Operating System	Linux RT
Flash	4 GB
RAM	1 GB
Real Time Clock, RTC Back-up, Buzzer	Yes
Interface	
Ethernet port	3 (port 0 - 10/100/1000, port 1 - 10/100, port 2 - 10/100)
USB port	2 (Host V2.0, max. 500 mA)
Serial port	1 (RS-232, RS-485, RS-422, software configurable) Max 3 serial ports using plug-in modules.
SD card	Yes
Expansion	2 slot for plug in modules
Ratings	
Power supply	24 Vdc (10 to 32 Vdc)
Current Consumption	0.7 A at 24 Vdc (max.)
Input Protection	Electronic
Battery	Rechargeable Lithium battery, not user-replaceable
Environment Conditions	
Operating Temp	-20° to +60 °C (vertical installation) Plug-in modules and USB devices may limit max temperature to +50 °C
Storage Temp	-20°C to +70°C
Operating / Storage Humidity	5-85% RH, non condensing
Protection Class	IP69 (front), IP20 (rear)
Dimensions and Weights	
Faceplate LxH	217x177 mm (8.54x6.96")
Cutout AxB	176x136 mm (6.93x5.35")
Depth D+T	45+10 mm (1.77+0.4")
Weight	2.5 Kg
Approvals	
CE	Emission EN 61000-6-4, Immunity EN 61000-6-2 for installation in industrial environments
UL	cULus: UL61010-1 / UL61010-2-201
RCM	Yes

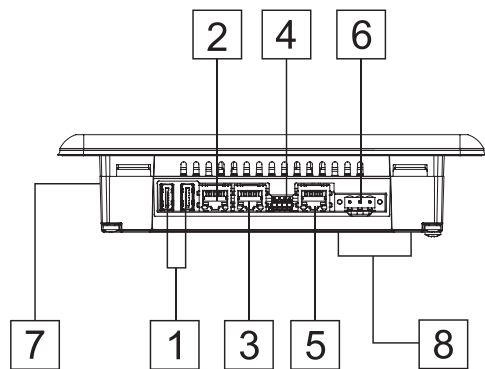

- 1 USB ports 1 and 2
- 2 Ethernet port 2 (10/100 Mb)
- 3 Ethernet port 1 (10/100 Mb)
- 4 Serial port
- 5 Ethernet port 0 (10/100/1000 Mb)
- 6 Power supply
- 7 SD Card slot
- 8 2 Expansion slots for plugin modules

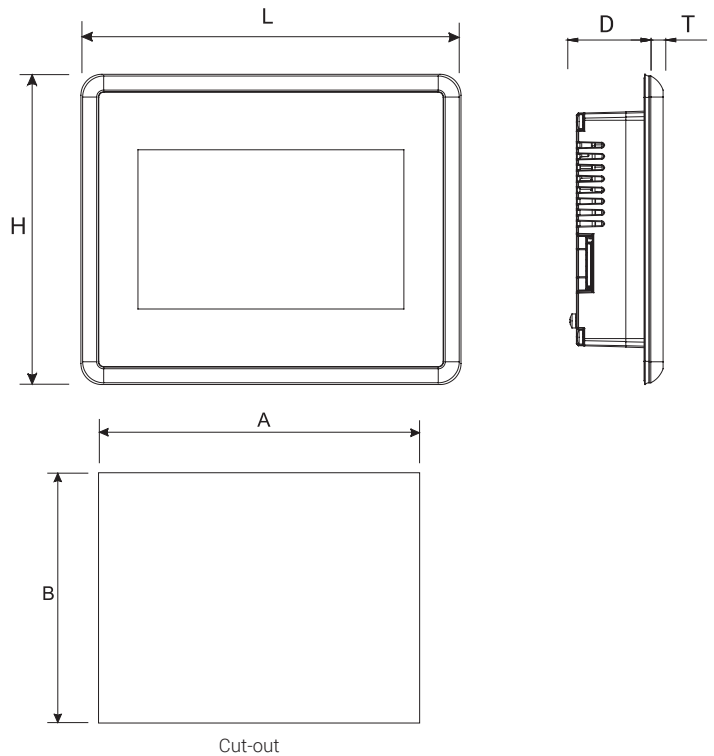

## Ordering Information

Model	Part Number	Description
eX707FB	+EX707U4F1	7" widescreen TFT color projected capacitive touchscreen. Stainless steel bezel. Ethernet and USB interfaces. JMobile runtime. Blue front panel



# SCATTERGOOD & JOHNSON LTD

ELECTRICAL ENGINEERING & FLUID CONTROL DISTRIBUTORS

Est.1899

At Scattergood & Johnson Ltd, we pride ourselves on being a technical distributor to specialist industries.

Working with a range of quality product suppliers across a number of specialist markets, we are not your average 'box shifter' - we are your technical and supply chain partner.

We fully support every product we sell - for free! Our internal team and external sales engineers can answer any product or application question, no matter the complexity.

Backing up this technical ability is a range of 50,000+ products available from stock for nationwide next day delivery (same day if required!), or you can collect what you need from any of our trade counters around the UK.

Select your specialist interest below to learn more about how we can help.



Online, In Branch and On the Road - Scattergood & Johnson Ltd, there when you need us.

# [www.scatts.co.uk](http://www.scatts.co.uk)