

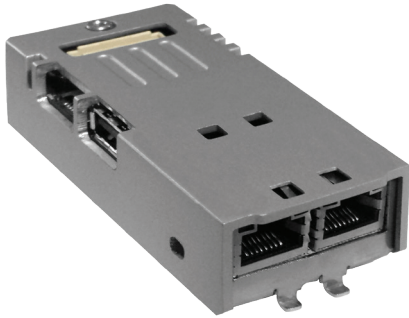

PLCM07 Secure Cloud Connector Tech-Note

PLCM07 Secure Cloud Connector is a plug-in module that creates a secure VPN router for use with the Corvina Cloud connectivity architecture. The plug-in is compatible with Series 500, 500G, 600.



- Includes openVPN/SSL software
- Firewall-friendly connections
- Dual Ethernet ports (WAN/LAN)
- Easy module update with USB and SD interfaces

Highlights

The PLCM07 Secure Cloud Connector is low cost solution designed for remote assistance and data acquisition for the Series 500, 500G, 600.

- Secure connection for industrial remote connectivity
- Based on Corvina Cloud Switchboard Server using secure connection based on OpenVPN/SSL
- Routing for direct access to remote sub-networks (i.e. PLC communications)
- Remote desktop for diagnostic of HMI applications
- Integration with JMobile Studio for remote update of OS, JM Runtime and applications
- Integration with JM4Web for remote web access
- Support virtual serial communication (pending)
- Communication support for programming remote PLC (Ethernet/serial)
- Compatible with main PLC brands
- Simple management of users/groups and devices/groups with Corvina Cloud software

Technical Data

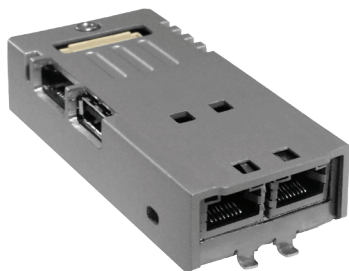

| System Resources | |
|--------------------------------|---|
| CPU | ARM Cortex A8 1 GHz |
| Operating System | Linux 3.12 |
| RAM | 512 MB |
| Flash | 4 GB |
| Interfaces | |
| Ethernet | 2x 10/100 Mbit |
| USB | 1x Host (V2.0, max. 500 mA) |
| Memory Card | microSD card slot |
| Environmental Conditions | |
| Operating temperature | -20° to +60°C |
| Storage temperature | -20° to +70°C |
| Operating and storage humidity | 5 – 85 % relative humidity, non-condensing |
| Protection class | IP20 |
| Approvals | |
| CE | Emission EN 61000-6-4, Immunity EN 61000-6-2 for installation in industrial environments. Emission EN 60945, Immunity EN 60945 for marine environments |
| RCM | Yes |

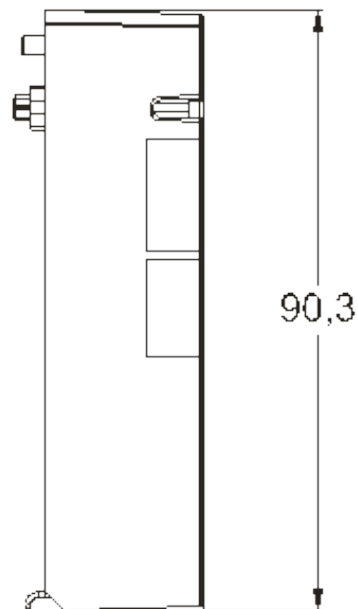
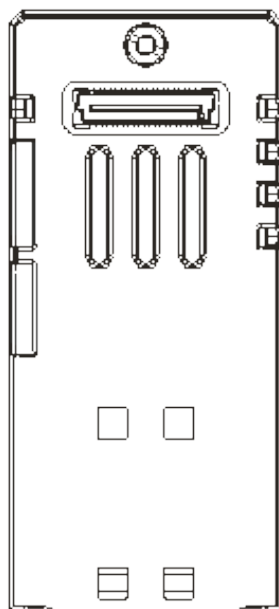
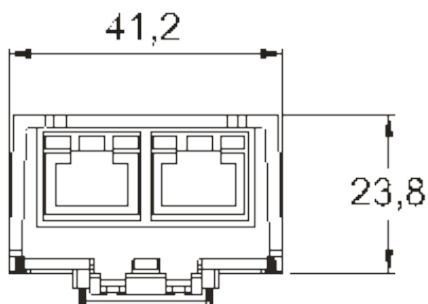

Ordering Information

| Model | Part Number | Description |
|--------|-------------|---|
| PLCM07 | +PLCM07U0P1 | Router Plug-in – Secure Cloud Connector |



SCATTERGOOD & JOHNSON LTD

ELECTRICAL ENGINEERING & FLUID CONTROL DISTRIBUTORS

Est.1899

At Scattergood & Johnson Ltd, we pride ourselves on being a technical distributor to specialist industries.

Working with a range of quality product suppliers across a number of specialist markets, we are not your average 'box shifter' - we are your technical and supply chain partner.

We fully support every product we sell - for free! Our internal team and external sales engineers can answer any product or application question, no matter the complexity.

Backing up this technical ability is a range of 50,000+ products available from stock for nationwide next day delivery (same day if required!), or you can collect what you need from any of our trade counters around the UK.

Select your specialist interest below to learn more about how we can help.



Online, In Branch and On the Road - Scattergood & Johnson Ltd, there when you need us.

www.scatts.co.uk