

OPTIPOINT PLUS

Remote Keypad Option Module

User Guide

Installation and Operating Instructions



SAFETY

Optiport Plus is designed to be used in conjunction with the Optidrive Plus variable speed drive and is intended for professional incorporation into complete equipment or systems. The Optiport Plus can be used to control the operation of the Optidrive 3^{GV}, Optidrive VTC or Optidrive Plus 3^{GV} Compact. The drive must be installed correctly to prevent a safety hazard. The Optidrive uses high voltages and currents, carries a high level of stored electrical energy, and is used to control mechanical plant that may cause injury. Close attention is required to system design and electrical installation to avoid hazards in either normal operation or in the event of equipment malfunction.

System design, installation, commissioning and maintenance must be carried out only by personnel who have the necessary training and experience. They must read carefully this safety information and the instructions in this and the Optidrive User Guide and follow all information regarding transport, storage, installation and use, including the specified environmental limitations.

Please read the **IMPORTANT SAFETY INFORMATION** below, and all **Warning** and **Caution** boxes elsewhere.

SAFETY NOTICES

WARNING is given where there is a hazard that could lead to injury or death of personnel.
CAUTION is given where there is a hazard that could lead to damage to equipment.

DM Jones
Dr David Jones, R&D Director

MECHANICAL INSTALLATION

WARNING

- When installing the Optiport Plus, all Optidrives should be disconnected and **ISOLATED** before attempting any work. High voltages are present at the terminals and within the drive for up to 10 minutes after disconnection of the electrical supply. The Optidrives should be installed by qualified electrical persons and in accordance with local and national regulations and codes of practice.
- Refer to Optidrive manual for further details.

CAUTION

- Carefully inspect the Optiport before installation to ensure it is undamaged.
- Store the Optiport in its box until required. Storage should be clean and dry. Temperature range -40°C to +60°C.
- Install the Optiport on a flat, flame-resistant vibration-free surface.
- Flammable material should not be placed close to the Optiport.

DIMENSION

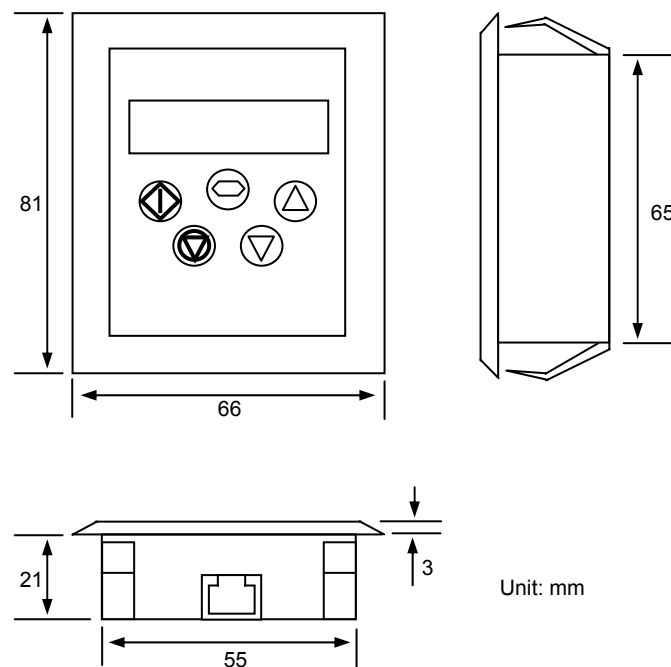

THROUGH PANEL MOUNT

The panel on to which the Optiport Plus is to be mounted should be cut out in accordance with the diagram below.

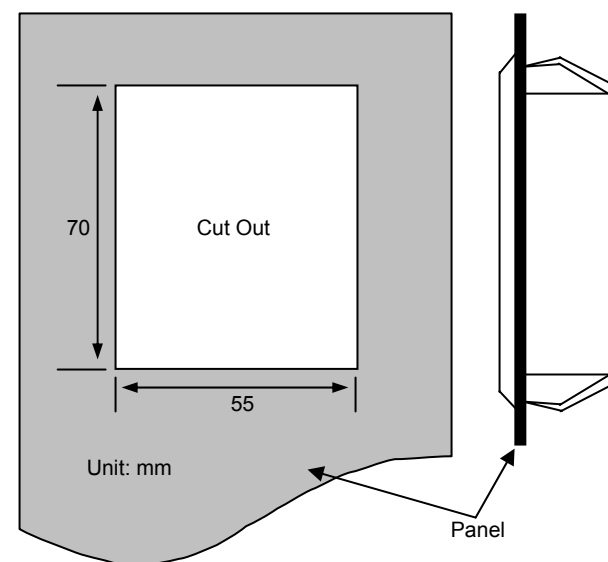

ELECTRICAL INSTALLATION

Electrical Interface

The Optiport Plus uses a standard RJ11 6-Way connector as its electrical interface, which provides a simple solution for the user to setup their system using a standard RJ11 6-Way data cable. The signal layout of the connector is as follows:

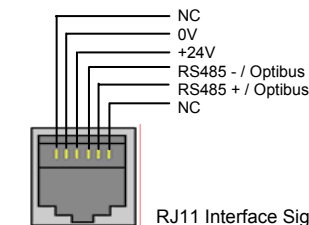

Cable Requirements

Standard 6-way data cables with plugs are available from Invertek Drives Ltd in 0.3, 1 and 3 metre lengths. If the data cable is made up on site, ensure that the connection pin out is correct: Pin 1 to Pin 1, Pin 6 to Pin 6 etc.

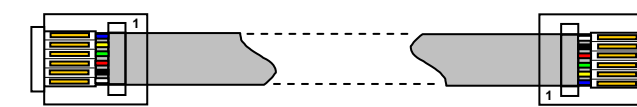

CAUTION

Incorrect cable connection may damage the drive. Extra care should be taken when using third party cable.

System Setup

The Optidrive provides the power supply to the Optiport Plus via the RJ11 connection. Once the physical connection has been setup, the system is ready to operate. See picture below:



DECLARATION

All rights reserved. No part of this User Guide may be reproduced or transmitted in any form or by any means, electrical or mechanical including photocopying, recording or by any information storage or retrieval system without permission in writing from the publisher.

Copyright Invertek Drives Ltd © 2005

The manufacturer accepts no liability for any consequences resulting from inappropriate, negligent or incorrect installation, or adjustment of the optional operating parameters of the drive or from mismatching of the drive to the motor.

The contents of this User Guide are believed to be correct at the time of printing. In the interests of a commitment to a policy of continuous improvement, the manufacturer reserves the right to change the specification of the product or its performance or the contents of the User Guide without notice.

WARRANTY

All Invertek Drives Ltd (IDL) products carry a 2-year warranty, valid from the date of manufacture. This date is clearly visible on the rating label.

Complete Warranty Terms and Conditions are available upon request to your IDL Authorised Distributor.

INVERTEK DRIVES LTD
Offa's Dyke Business park
Welshpool
Powys
SY21 8JF
UK

Tel +44 (0) 1938 556868
Fax +44 (0) 1938 556869
E-mail enquiry@invertek.co.uk
Internet www.invertek.co.uk

Part No. 82-OPTPLS-01

V 1.02 January 2008

IMPORTANT SAFETY INFORMATION

Safety of machinery, and safety-critical applications

The level of integrity offered by the Optiport Plus / Optidrive control functions – for example stop/start, forward/reverse and maximum speed, is not sufficient for use in safety-critical applications without independent means of protection. All applications where malfunction could cause injury or loss of life must be subject to a risk assessment and further protection provided where needed.

Within the European Union, all machinery in which this product is used must comply with Directive 89/392/EEC, Safety of Machinery. In particular, the electrical equipment should comply with EN60204-1.

CONFORMITY WITH STANDARDS FOR OPTIDRIVE

- CE-marked for Low Voltage Directive.
- EN61000-4 EMC Generic Emissions Standard, Industrial Level.
- EN61000-2 EMC Generic Immunity Standard, Industrial Level.
- Enclosure ingress protection, EN60529, NEMA 250.
- Flammability rating according to UL 94.

GENERAL SPECIFICATION

Signal Interface: Standard 6-way RJ11 connector
Supply Input: 10V ... 36V DC, 30mA
RS485 signal: industry standard 2-wire +5V differential
Environmental: Operational 0 ... 50 °C
Storage -40 °C ... 60 °C
Relative Humidity < 95% (non condensing)
Protection rating: IP54
Max cable length: 20m (total length)

USER INTERFACE

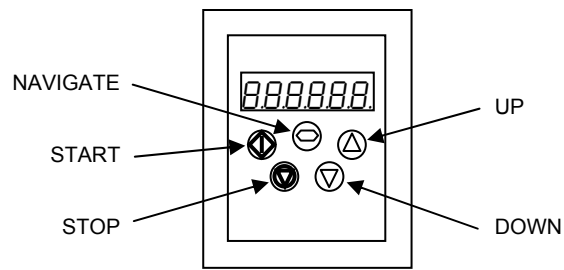

NAVIGATE:
Used to display real-time information, to access and exit parameter edit mode and to store parameter changes

UP:
Used to increase speed in real-time mode or to increase parameter values in parameter edit mode

DOWN:
Used to decrease speed in real-time mode or to decrease parameter values in parameter edit mode

RESET / STOP:
When drive is in trip mode, this button is used to reset a tripped drive. In normal application, when in Keypad mode, this button is used to stop a running drive.

START:
When in keypad mode, the button is used to start a stopped drive or to reverse the direction of rotation if bi-directional keypad mode is enabled (See drive user guide for more information).

SYSTEM SETUP

Depending on the requirement of the application, Optiport Plus can be used in the following four different ways:

- One Optiport Plus with one Optidrive



- One Optiport Plus with up to 63 Optidrive

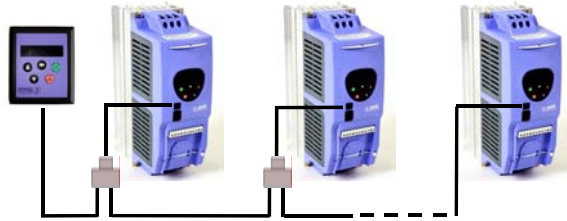

- Two Optiport Plus units with one Optidrive



- Two Optiport Plus units with up to 63 Optidrive

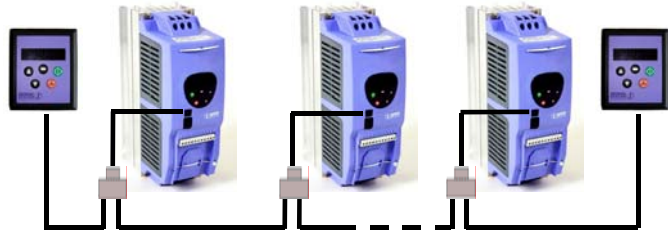

Note: The splitter is available from Invertek Drives Ltd on request.

EASY STARTUP

To setup the communication address

By default, the Optiport Plus will try to communicate with the drive that has address 1 in the network following powering up for the first time.

The Optiport Plus will initially display "SCAN.." after power up, which indicates that the Optiport Plus is searching for the drive with address number 1 in the network. Once the drive has been found, the message "Load.." will be displayed on the Optiport Plus display window, which indicates that the Optiport Plus is reading the configuration information from the drive. Usually it will take 1~2 seconds for the Optiport Plus to read this information. After the data has been loaded, Optiport Plus will display the drive real time status.

If the Optiport Plus doesn't find drive address 1 in the network, i.e. there is only one drive in the network and its address is not equal to 1, the Optiport Plus will request the user to enter an alternative address. The display will show "Adr-01". The user can then adjust the address from 1 to 63 by using the UP or DOWN buttons on the Optiport Plus. Once the address has been changed to a value to match that of a connected drive, the STOP button must be pressed to enable the Optiport Plus to search for the drive again.

If the Optiport Plus is connected to a network of multiple drives, the user can select the required drive address to communicate with at any time. Pressing the STOP and DOWN buttons together results in the message "Adr-XX", where "XX" represents the present address. The UP or DOWN buttons can now be used to select the desired drive address. After selecting the new address, pressing STOP and DOWN button together again will result in Optiport Plus establishing communications with the drive that has this address.

To setup Optiport Plus device number

The user can use a maximum of 2 Optiport Plus units within the same drive network to communicate with the same drive or different drives.

When using two Optiport Plus units with the same drive, the user needs to change the Optiport Plus Device Number on the second Optiport Plus to ensure correct operation. All Optiport Plus units are set to Device Number 1 by default.

To change the Device Number, press the NAVIGATE, STOP and DOWN buttons together. The message "Port-X" (x = 1 or 2) will be displayed. The User can then use the UP or DOWN buttons to change the Optiport Plus Device Number to 1 or 2 as required. Press NAVIGATE, STOP and DOWN button together again to return to normal operation.

Note:

- Once the User has set the Optiport Plus as Device Number 2, Optiport Plus can not be used on the same drive network.
- The Optiport Plus Device Address should only be changed to 2 if 2 Optiport Plus units are connected on a network. An Optiport Plus with Device Number 1 must always be present for the network to function correctly.

REAL TIME OPERATION

Once the communication has been established between the Optidrive and Optiport Plus, the user can control the Optidrive Plus by using the control buttons on the front panel of the Optiport Plus.

To monitor or change a parameter value

- Press and hold the NAVIGATE key for more than 1s when the drive is displaying "StoP". The display changes to P1-01, indicating parameter 01 in parameter group 1.
- Press and release the NAVIGATE key to display the value of this parameter.
- Change to the required value using the UP and DOWN keys.
- Press and release the NAVIGATE key once more to store the change.
- Press and hold the NAVIGATE key for more than 1s to return to real-time mode. The display shows "StoP" if the drive is stopped or the real-time information (e.g. speed, current or power) if the drive is running.

To change parameter group

Ensure that extended parameter group access is enabled. The default extended parameter access code is 101 and this should be entered in P1-14 to enable the extended parameter group access. Enter parameter edit mode with parameter number PX-XX displayed. Press NAVIGATE button and then simultaneously press and release the UP or DOWN key to change the parameter group number until the required parameter group is displayed.

NOTE

For detailed parameter listing and functional setup, please refer to the corresponding Optidrive user guide

Locking access to the parameters

- To prevent unauthorised access to the parameters via the Optiport Plus, set P2-38 = 1. Once this parameter has been set, access to parameters via the Optiport Plus will be prevented.
- The operational information (e.g. speed, current, power etc) can be still accessed as normal and the drive can still be controlled from the keypad.
- To unlock parameter access, change P2-38 back to 0 via the drive keypad directly.

Presetting target speed in keypad mode

Set P1-12 = 1 or 2 to enable the keypad control, ensuring that P2-19 = 1 or 3 to enable the drive to start from the preset speed. Whilst the drive is stopped, press the STOP key. The value of the digital potentiometer will be displayed, indicating target speed. Use the UP and DOWN keys to select the required target speed.

Press the STOP key to return to the real time display showing "StoP", or the START key to start the drive ramping up to the target speed.

NOTE

The hardware enable on the drive must be present when using keypad control mode.

To vary the speed in real time in keypad control mode

Press the START key. The drive will ramp up to the preset speed set in the digital potentiometer (assuming P2-19 = 1).

Press UP to increase speed. The drive will run forward, increasing speed until the UP button is released. The maximum speed is the speed set in P1-01.

Press DOWN to decrease speed. The drive will decrease speed until the STOP button is released. The minimum speed is the speed set in P1-02.

Pressing the STOP key to stop the drive (suppose P2-19 = 1). The drive will decelerate to stop at the selected deceleration ramp. The display will finally show "StoP" at which point the drive is disabled.

Pressing the START key once more results in the drive running back up to the speed at which it was previously running (digital potentiometer value). (assuming P2-19 = 1)

To reverse direction of rotation with P1-12 = 2

Press the START key. The drive ramps up to the preset speed as set in the digital potentiometer (assuming P2-19 = 1).

Press UP or DOWN to increase or decrease the speed.

Press the START key again. The motor will reverse its direction of rotation.

Press the STOP key to decelerate the motor to standstill.

Whenever the drive is started, it will start with a positive speed unless the direction is negated by the digital inputs on the user terminals.

UNDERSTANDING THE DISPLAY MESSAGES

Optiport Plus uses various display messages to indicate different working status. See the following table for more information.

Message	Explanation
SCAN..	The Optiport Plus is searching for the drive in the network.
LOAD..	The Optiport Plus has found the drive in the network and is loading the initialisation information from the drive.
Err-id	Indicates that the Optiport Plus has detected another Optiport Plus in the same network with the same device number.
Err-SC	The Optiport Plus has lost the communication link to the drive.
Adr-XX	Indicates the Optiport Plus address, where XX= 1...63
Port-X	This message shows the Optiport Plus device number X = 1 or 2

TROUBLE SHOOTING

Symptom	Explanation
'Adr-XX' displayed after 'SCAN..' message	Optiport Plus failed to find the drive with the specified address in the network. Check that the RJ11 data cable connection is correct. Check that the drive with address XX is available in the whole network. If XX > 1 and only one Optiport Plus is connected, then check the Optiport Plus device number, make sure the number is 1.
Display 'Err-id' on power up	This normally occurs when there are two Optiport Plus units in the same drive network and both of them have the same device number. Check and change the device number of one Optiport Plus.
Display 'Err-id' during normal operation	This normally occurs when the user plugs a second Optiport Plus into the drive network. Change the device number of one of the Optiport Plus units.
Display 'Err-SC'	Check the electrical connection, and make sure the cable is connected correctly between the Optiport Plus and drive. Press 'STOP' button to enable the Optiport Plus to search the drive again.

DRIVE TRIP CODE

Trip message	Explanation
"P-dEF"	Default parameters loaded.
"O-I"	Over-current on drive output to motor.
"I.t-trP"	Drive overload trip.
"O-Uolt"	Over-voltage on DC bus.
"U-Uolt"	Under-voltage trip.
"OI-b"	Over current in the brake resistor circuit.
"OL-br"	Brake resistor overload.
"O-t"	Over-temperature trip.
"U-t"	Under-temperature trip.
"PS-trP"	Power stage rating error.
"dAtA-F"	Internal memory data checksum error.
"P-LOSS"	One phase of the three phase input supply loss.
"Ph-Ib"	Three phase input voltage imbalance.
"SC-trP"	Drive communication link loss.
"E-triP"	External trip (connected to digital input 3).
"At-Fxx"	Auto-tune failed error with error code

For detail trouble shooting information, please refer to the corresponding drive user guide.



Invertek Drives Ltd adopts a policy of continuous improvement and whilst every effort has been made to provide accurate and up to date information, the information contained in this brochure should be used for guidance purposes only and does not form the part of any contract.



SCATTERGOOD & JOHNSON LTD

ELECTRICAL ENGINEERING & FLUID CONTROL DISTRIBUTORS

Est.1899

At Scattergood & Johnson Ltd, we pride ourselves on being a technical distributor to specialist industries.

Working with a range of quality product suppliers across a number of specialist markets, we are not your average 'box shifter' - we are your technical and supply chain partner.

We fully support every product we sell - for free! Our internal team and external sales engineers can answer any product or application question, no matter the complexity.

Backing up this technical ability is a range of 50,000+ products available from stock for nationwide next day delivery (same day if required!), or you can collect what you need from any of our trade counters around the UK.

Select your specialist interest below to learn more about how we can help.



Online, In Branch and On the Road - Scattergood & Johnson Ltd, there when you need us.

www.scatts.co.uk