

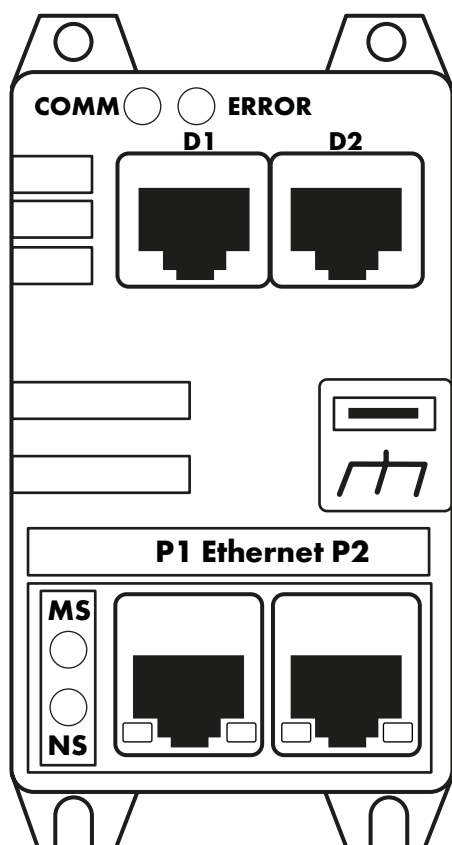

Ethernet IP Interface

OPT-2-ETHEG-IN



Introduction	1
General Information	2
Mechanical Installation	3
Electrical Installation	4
Drive Parameter Settings	5
Operation	6
Technical Data	7

1. Introduction	4
1.1. Important Safety Information	4
2. General Information	5
2.1. Overview	5
2.2. Labelling	5
2.3. Connection Ports	6
2.4. Status Indicator LEDs	6
2.5. Power up sequence	7
3. Mechanical Installation	8
3.1. Before Installation	8
3.2. General	8
3.3. Mechanical Dimensions and Weight	8
4. Electrical Installation	9
4.1. Overview	9
4.2. Connection Diagram	9
4.3. Grounding	9
5. Drive Parameter Settings	10
5.1. Overview	10
5.2. Optidrive Communication Parameters Overview	10
6. Operation	13
6.1. Overview	13
6.2. Configuration	13
6.3. Controlling a Drive via Ethernet/IP	13
6.4. Process Data Exchange	14
6.5. Process Data PDI	15
6.6. Process Data PDO	15
6.7. OPT-2-ETHEG-IN Web Server	18
6.8. Drive parameter access	20
6.9. Working with Rockwell Automation RSLogix5000	21
7. Technical Data	22
7.1. Environmental	22

Declaration of Conformity

Invertek Drives Ltd hereby states that the Optidrive Eco product range conforms to the relevant safety provisions of the following council directives:

2014/30/EU (EMC) and 2014/35/EU (LVD)

Design and manufacture is in accordance with the following harmonised European standards:

EN 61800-5-1: 2003	Adjustable speed electrical power drive systems. Safety requirements. Electrical, thermal and energy.
EN 61800-3 2nd Ed: 2004	Adjustable speed electrical power drive systems. EMC requirements and specific test methods.
EN 55011: 2007	Limits and Methods of measurement of radio disturbance characteristics of industrial, scientific and medical (ISM) radio-frequency equipment (EMC).
EN60529: 1992	Specifications for degrees of protection provided by enclosures.

Electromagnetic Compatibility

All Optidrive units are designed with high standards of EMC in mind. All versions suitable for operation on Single Phase 230 volt and Three Phase 400 volt supplies and intended for use within the European Union are fitted with an internal EMC filter. This EMC filter is designed to reduce the conducted emissions back into the mains supply via the power cables for compliance with the above harmonised European standards.

It is the responsibility of the installer to ensure that the equipment or system into which the product is incorporated complies with the EMC legislation of the country of use, and the relevant category. Within the European Union, equipment into which this product is incorporated must comply with the EMC Directive 2004/108/EC. This User Guide provides guidance to ensure that the applicable standards may be achieved.

Copyright Invertek Drives Ltd © 2017

All rights reserved. No part of this User Guide may be reproduced or transmitted in any form or by any means, electrical or mechanical including photocopying, recording or by any information storage or retrieval system without permission in writing from the publisher.

2 Year Warranty

All Invertek Optidrive units carry a 2 year warranty against manufacturing defects from the date of manufacture. The manufacturer accepts no liability for any damage caused during or resulting from transport, receipt of delivery, installation or commissioning. The manufacturer also accepts no liability for damage or consequences resulting from inappropriate, negligent or incorrect installation, incorrect adjustment of the operating parameters of the drive, incorrect matching of the drive to the motor, incorrect installation, unacceptable dust, moisture, corrosive substances, excessive vibration or ambient temperatures outside of the design specification.

The local distributor may offer different terms and conditions at their discretion, and in all cases concerning warranty, the local distributor should be contacted first.



This user guide is the “original instructions” document. All non-English versions are translations of the “original instructions”.

The contents of this User Guide are believed to be correct at the time of printing. In the interest of a commitment to a policy of continuous improvement, the manufacturer reserves the right to change the specification of the product or its performance or the contents of the User Guide without notice.

This User Guide is for use with version 1.00 Firmware.

User Guide Revision 1.10

Invertek Drives Ltd adopts a policy of continuous improvement and whilst every effort has been made to provide accurate and up to date information, the information contained in this User Guide should be used for guidance purposes only and does not form the part of any contract.

	This manual is intended as a guide for proper installation. Invertek Drives Ltd cannot assume responsibility for the compliance or the non-compliance to any code, national, local or otherwise, for the proper installation of this drive or associated equipment. A hazard of personal injury and/or equipment damage exists if codes are ignored during installation.
	This Optidrive contains high voltage capacitors that take time to discharge after removal of the main supply. Before working on the drive, ensure isolation of the main supply from line inputs. Wait ten (10) minutes for the capacitors to discharge to safe voltage levels. Failure to observe this precaution could result in severe bodily injury or loss of life.
	Only qualified electrical personnel familiar with the construction and operation of this equipment and the hazards involved should install, adjust, operate, or service this equipment. Read and understand this manual and other applicable manuals in their entirety before proceeding. Failure to observe this precaution could result in severe bodily injury or loss of life.

1. Introduction

1.1. Important Safety Information

Please read the IMPORTANT SAFETY INFORMATION below, and all Warning and Caution information elsewhere.



Danger: Indicates a risk of electric shock, which, if not avoided, could result in damage to the equipment and possible injury or death.

This variable speed drive product (Optidrive) is intended for professional incorporation into complete equipment or systems as part of a fixed installation. If installed incorrectly it may present a safety hazard. The Optidrive uses high voltages and currents, carries a high level of stored electrical energy, and is used to control mechanical plant that may cause injury. Close attention is required to system design and electrical installation to avoid hazards in either normal operation or in the event of equipment malfunction. Only qualified electricians are allowed to install and maintain this product.

System design, installation, commissioning and maintenance must be carried out only by personnel who have the necessary training and experience. They must carefully read this safety information and the instructions in this Guide and follow all information regarding transport, storage, installation and use of the Optidrive, including the specified environmental limitations.

Do not perform any flash test or voltage withstand test on the Optidrive. Any electrical measurements required should be carried out with the Optidrive disconnected.

Electric shock hazard! Disconnect and ISOLATE the Optidrive before attempting any work on it. High voltages are present at the terminals and within the drive for up to 10 minutes after disconnection of the electrical supply. Always ensure by using a suitable multimeter that no voltage is present on any drive power terminals prior to commencing any work.

Where supply to the drive is through a plug and socket connector, do not disconnect until 10 minutes have elapsed after turning off the supply.

Ensure correct earthing connections and cable selection as per defined by local legislation or codes. The drive may have a leakage current of greater than 3.5mA; furthermore the earth cable must be sufficient to carry the maximum supply fault current which normally will be limited by the fuses or MCB. Suitably rated fuses or MCB should be fitted in the mains supply to the drive, according to any local legislation or codes.

Do not carry out any work on the drive control cables whilst power is applied to the drive or to the external control circuits. The "Safe Torque Off" Function does not prevent high voltages from being present at the drives power terminals.



Danger: Indicates a potentially hazardous situation other than electrical, which if not avoided, could result in damage to property.

Within the European Union, all machinery in which this product is used must comply with the Machinery Directive 2006/42/EC, Safety of Machinery. In particular, the machine manufacturer is responsible for ensuring that the electrical equipment complies with EN60204-1 and providing a disconnecting device which must be one of the following types:

- A switch-disconnector, utilization category AC-23B (EN 60947-3).
- A circuit breaker suitable for isolation in accordance with EN 60947-2.
- A disconnector with an integrated auxiliary contact that ensures under all circumstances the switching devices break the load circuit prior to opening of the main contacts of the disconnector (EN 60947-3).

For installation in other regions, conformance with local electrical regulations and codes of practice must be adhered to.

The level of integrity offered by the Optidrive control input functions – for example stop/start, forward/reverse and maximum speed, is not sufficient for use in safety-critical applications without independent channels of protection. All applications where malfunction could cause injury or loss of life must be subject to a risk assessment and further protection provided where needed.

The driven motor can start at power up if the enable input signal is present.

The STOP function does not remove potentially lethal high voltages. ISOLATE the drive and wait 10 minutes before starting any work on it. Never carry out any work on the Drive, Motor or Motor cable whilst the input power is still applied.

The Optidrive can be programmed to operate the driven motor at speeds above or below the speed achieved when connecting the motor directly to the mains supply. Obtain confirmation from the manufacturers of the motor and the driven machine about suitability for operation over the intended speed range prior to machine start up.

Do not activate the automatic fault reset function on any systems whereby this may cause a potentially dangerous situation.

IP55 and IP66 drives provide their own pollution degree 2 environments. IP20 drives must be installed in a pollution degree 2 environment, mounted in a cabinet with IP54 or better.

Optidrives are intended for indoor use only.

When mounting the drive, ensure that sufficient cooling is provided. Do not carry out drilling operations with the drive in place, dust and swarf from drilling may lead to damage.

The entry of conductive or flammable foreign bodies should be prevented. Flammable material should not be placed close to the drive. Relative humidity must be less than 95% (non-condensing).

Ensure that the supply voltage, frequency and no. of phases (1 or 3 phase) correspond to the rating of the Optidrive as delivered.

Never connect the mains power supply to the Output terminals U, V, W.

Do not install any type of automatic switchgear between the drive and the motor.

Wherever control cabling is close to power cabling, maintain a minimum separation of 100 mm and arrange crossings at 90 degrees.

Ensure that all terminals are tightened to the appropriate torque setting.

Do not attempt to carry out any repair of the Optidrive. In the case of suspected fault or malfunction, contact your local Invertek Drives Sales Partner for further assistance.

2. General Information

2.1. Overview

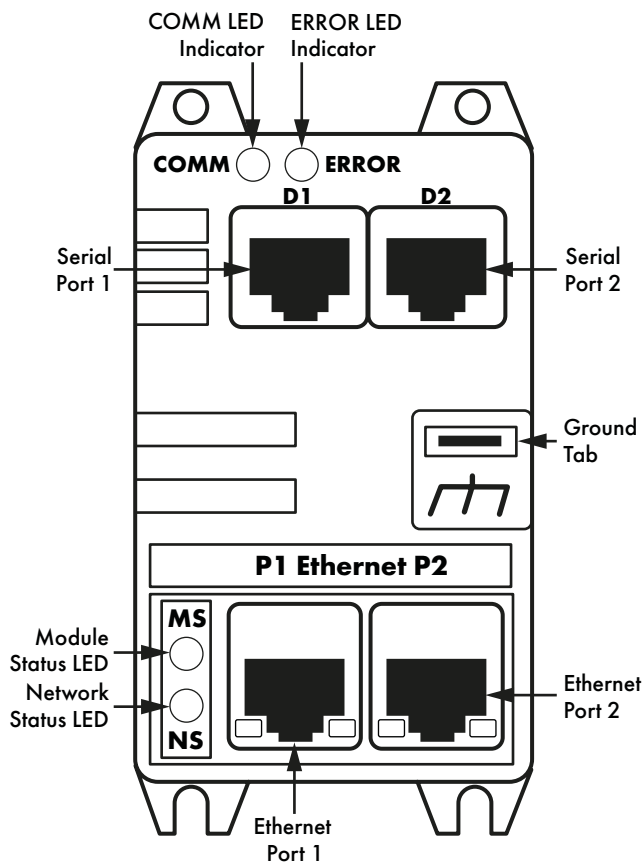

2.2. Labelling

The OPT-2-ETHEG-IN has two labels, as shown below.

Top Label:

Provides the MAC ID and PR ID Data for the module.



Side Label:

Provides the model code and serial number data.

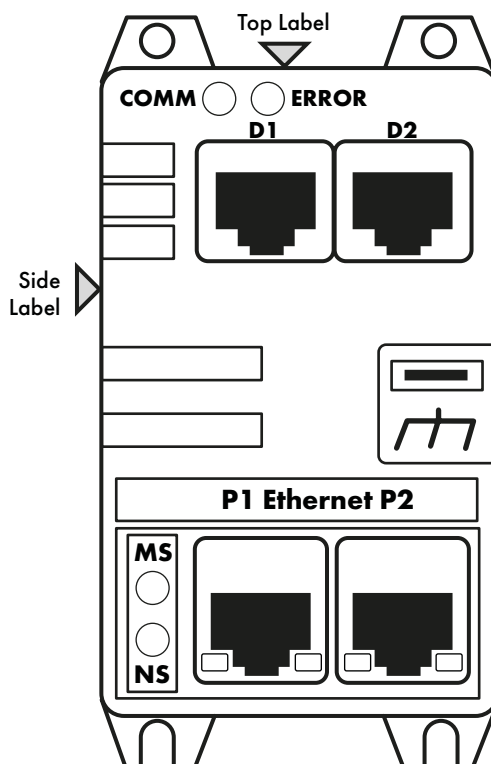

2.3. Connection Ports

The interface connects to the Ethernet IP network and slave drive via the built in connection ports.

Port	Function
P1	Ethernet Port 1
P2	Ethernet Port 2
IOIO1 1	RJ45 Drive Data Connection
IOIO1 2	RJ45 Aux equipment Connection

2.4. Status Indicator LEDs

Status LED	Function
NS	EtherNet/IP Network Status Indicator
MS	MS: EtherNet/IP Network Status Indicator
COMM	COMM: Modbus Communication Indicator (OPC-2-ETHIG-IN <-> Drive)
ERROR	Modbus Error Indicator (OPC-2-ETHIG-IN <-> Drive)

Network Status Indicator

State	Indication
Steady Off	Not powered, no IP address
Steady Green	Online, one or more connections active
Flashing Green	Online, no connections active
Flashing Red	Connection timeout
Steady Red	Duplicate IP
Flashing Green and Red	Self-test

Module Status Indicator

State	Indication
Steady Off	No power
Steady Green	Operating in normal condition
Flashing Green	Drive not configured
Flashing Red	Minor fault - Recoverable fault
Steady Red	Major fault - Unrecoverable fault
Flashing Green / Red	Self-test

COMM

State	Indication
Steady Off	Modbus protocol TX/RX inactive
Steady/flashing Yellow	Modbus protocol TX/RX active

ERROR

State	Indication
Steady Off	Modbus protocol TX/RX Status OK
Steady Red	Non-recoverable internal fault – Modbus communications circuit fault
Flashing Red	Recoverable Communication fault or configuration error

Link Activity LEDs (P1/P2)		
	State	Indication
P1 Speed	Steady Yellow	100Mbps link active
	Steady Off	10Mbps or No link
P1 Link Activity	Steady Green	Valid Link
	Steady Off	No Link
	Flash	TX/RX
P2 Speed	Steady Yellow	100Mbps link active
	Steady Off	10Mbps or No link
P2 Link Activity	Steady Green	Valid Link
	Steady Off	No Link
		TX/RX

2.5. Power up sequence

At power up the following LED test sequence is performed in parallel:

- Network Status Indicator – 0.25 sec RED, 0.25 sec Green.
- Module Status Indicator – 0.25 sec RED, 0.25 sec Green.
- COMM – 0.5 sec Yellow, 0.5 sec Off.
- ERROR – 0.5 sec Off, 0.5 sec RED.
- 'Running' state.

3. Mechanical Installation

3.1. Before Installation

- Carefully unpack the unit and check for any signs of damage. Notify the shipper immediately if any exist.
- To prevent accidental damage always store the unit in its original box until required.
- Storage should be clean and dry and within the temperature range -40°C to +60°C.

3.2. General

- The Ethernet IP interface is intended for mounting inside a control cabinet adjacent to the drive.
- The unit should be mounted in a vertical position only, on a flat, flame resistant, vibration free mounting.
- The unit must be installed in a pollution degree 1 or 2 environment only.
- Use the module as a template to mark the locations for drilling the mounting screws.
- Drill and tap the holes as required.
- Secure the unit to the backplate using suitable screws.

3.3. Mechanical Dimensions and Weight

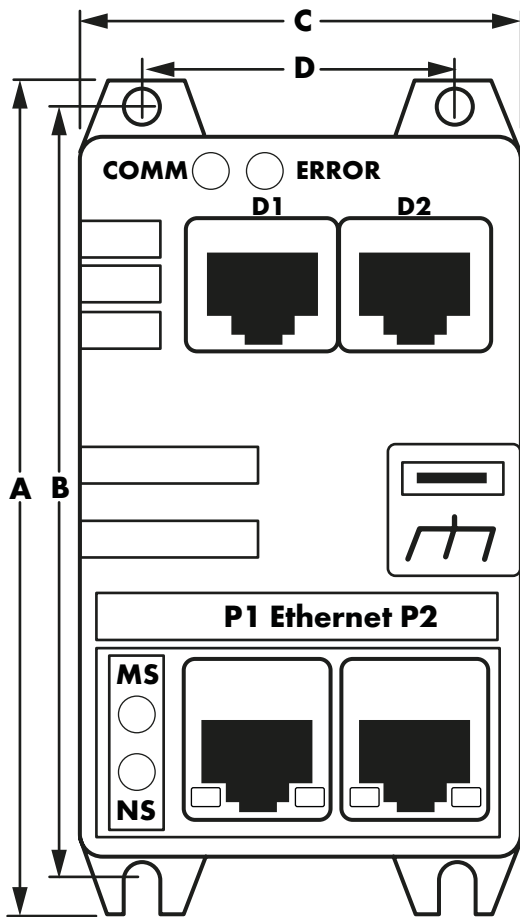

A		B		C		D		Weight	
mm	in	mm	in	mm	in	mm	in	g	Oz
89	3.50	76	2.99	47	1.85	31	1.22	65	2.29

Mounting Bolts	
Metric	UNF
M4	#8

Mechanical Installation

3

4. Electrical Installation

4.1. Overview

The OPT-2-ETHEG-IN is intended for operation with one of the following Invertek Drives' products:

- Optidrive E3
- Optidrive P2
- Optidrive Eco.

The unit connects via an RJ45 cable, which also supplies the power to the OPT-2-ETHEG-IN from the 24 Volt output of the Optidrive.

4.2. Connection Diagram

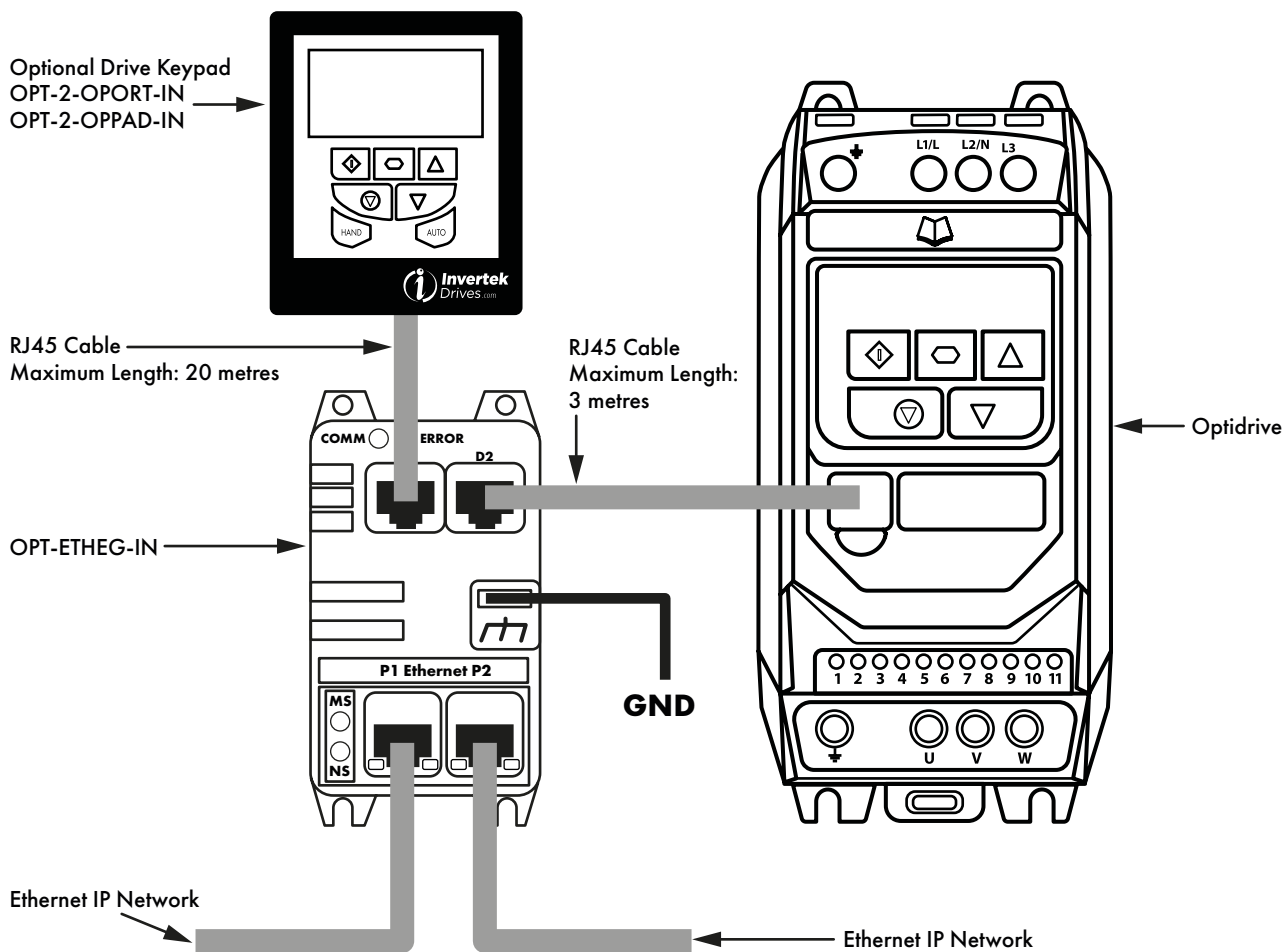

4.3. Grounding

For correct operation, ensure the Ground tab is connected to the control cabinet Ground point. Do not connect to the drive ground connection point.

5. Drive Parameter Settings

5.1. Overview

The OPT-2-ETHEG-IN connects to the Optidrive Modbus interface. The default settings for this interface, for both the drive and the OPT-2-ETHEG-IN are:

- Drive Address 1
- 115200 kbps baud rate
- 1 Start Bit
- 8 Data Bits
- 1 Stop Bit
- No Parity.

For all Optidrive products, the Modbus interface is always active for parameter access and monitoring, however in order to control the drive, the user must set the relevant control source parameter.

- For Optidrive 3, set P-12 = 3 or 4. See below for further information on these settings.
- For Optidrive P2 and Eco, set P1-12 = 4.

5.2. Optidrive Communication Parameters Overview

5.2.1. Optidrive E3

The following parameters are used to configure the communication interface of the Optidrive E3. Refer to the drive user guide for specific details of the functions of other parameters.

Par.	Description	Minimum	Maximum	Default	Units
P-12	Primary Command Source	0	9	0	-
	3: Ethernet IP. Control via OPT-2-ETHEG-IN using the internal Accel / Decel ramps. 4: Ethernet IP. Control via OPT-2-ETHEG-IN with Accel / Decel ramps updated via PDI Word 4. NOTE When P-12 = 1, 2, 3, 4, 7, 8 or 9, an enable signal must still be provided at the control terminals, digital input 1.				
P-14	Extended Menu Access code	0	65535	0	-
	Enables access to Extended and Advanced Parameter Groups. This parameter must be set to the value programmed in P-37 (default: 101) to view and adjust Extended Parameters and value of P-37 + 100 to view and adjust Advanced Parameters. The code may be changed by the user in P-37 if desired.				
P-36	Serial Communications Configuration	See Below			
	Index 1: Address	0	63	1	-
	Index 2: Baud Rate	9.6	1000	115.2	kbps
	Index 3: Communication loss protection	0	3000	† 3000	ms
	This parameter has three sub settings used to configure the Modbus RTU Serial Communications. The Sub Parameters are:				
1st Index: Drive Address: Range: 0 – 63, default: 1					
2nd Index: Baud Rate & Network type: Selects the baud rate and network type for the internal RS485 communication port. For Modbus RTU: Baud rates 9.6, 19.2, 38.4, 57.6, 115.2 kbps are available. For CAN Open: Baud rates 125, 250, 500 & 1000 kbps are available.					
3rd Index: Watchdog Timeout: Defines the time for which the drive will operate without receiving a valid command telegram to Register 1 (Drive Control Word) after the drive has been enabled. Setting 0 disables the Watchdog timer. Setting a value of 30, 100, 1000, or 3000 defines the time limit in milliseconds for operation. A 'E' suffix selects trip on loss of communication. An 'r' suffix means that the drive will coast stop (output immediately disabled) but will not trip.					

5.2.2. Optidrive P2 / Optidrive Eco

The following parameters are used to configure the communication interface of the Optidrive E3. Refer to the drive user guide for specific details of the functions of other parameters.

Par.	Description	Minimum	Maximum	Default	Units
P-12	Primary Command Source	0	9	0	-
	4 Fieldbus Control	Control via Modbus RTU if no fieldbus interface option is present, otherwise control is from the fieldbus option module interface.			
P1-13	Digital Inputs Function Select	0	21	1	-
	Defines the function of the digital inputs depending on the control mode setting in P1-12. See section 7.1. Environmental for more information.				
P1-14	Extended Menu Access Code	0	30000	0	-
	Parameter Access Control. The following settings are applicable: P1-14 = P2-40 = 101: Allows access to Extended Parameter Groups 0 – 5. P1-14 = P6-30 = 201: Allows access to all parameter groups (Intended for experienced users only, usage is not described in this User Guide).				
P5-01	Drive Fieldbus Address	0	63	1	-
	Sets the fieldbus address for the Optidrive.				
P5-05	Communications Loss Timeout	0.0	5.0	2.0	Seconds
	Sets the watchdog time period for the communications channel. If a valid telegram is not received by the Optidrive within this time period, the drive will assume a loss of communications has occurred and react as selected below. Setting to zero disables the function.				
P5-06	Communications Loss Action	0	3	0	-
	0 Trip & Coast To Stop				
	1 Ramp to Stop Then Trip				
	2 Ramp to Stop Only (No Trip)				
	3 Run at Preset Speed 8				
P5-07	Fieldbus Ramp Control	0	1	0	-
	0 Disabled	Ramps are control from internal drive parameters P1-03 and P1-04.			
	1 Enabled	Ramps are controlled directly by the Fieldbus PDI4 Data Word.			
P5-08	Fieldbus Process Data Output Word 4 Select	0	4	0	-
	0 Output Torque	0 to 2000 = 0 to 200.0%.			
	1 Output Power	Output power in kW to two decimal places, e.g. 400 = 4.00kW.			
	2 Digital Input Status	Bit 0 indicates digital input 1 status, bit 1 indicates digital input 2 status etc.			
	3 Analog Input 2 Signal Level	0 to 1000 = 0 to 100.0%.			
	4 Drive Heatsink Temperature	0 to 100 = 0 to 100°C.			
P5-12	Fieldbus Process Data Output Word 3 Select	0	7	0	-
	0 Motor current	Output current to 1 decimal place, e.g. 100 = 10.0 Amps.			
	1 Power (x.xx kW)	Output power in kW to two decimal places, e.g. 400 = 4.00kW.			
	2 Digital input status	Bit 0 indicates digital input 1 status, bit 1 indicates digital input 2 status etc.			
	3 Analog Input 2 Signal Level	0 to 1000 = 0 to 100.0%.			
	4 Drive Heatsink Temperature	0 to 100 = 0 to 100°C.			
	5 User register 1	User Defined Register 1 Value.			
	6 User register 2	User Defined Register 1 Value.			
	7 P0-80 value	User Selected data value.			
P5-13	Fieldbus Process Data Input Word 4 Select	0	1	0	-
	0 Fieldbus Ramp Control	This option must be selected if the drive acceleration and deceleration ramps are to be controlled from the fieldbus. P5-07 must also be set to 1 to enable this function.			
	1 User Register 4	The value received by the drive in PDI 4 is transferred to User Register 4. This option allows the function of the process data word to be defined in Parameter Group 9. In this case, User Register 4 should not be written to within any PLC function code, although the value can be read.			

Par.	Description	Minimum	Maximum	Default	Units
P5-14	Fieldbus Process Data Input Word 3 Select	0	2	0	-
	0 Torque Limit/Reference	This option must be selected if the drive output torque limit / setpoint are to be controlled from the fieldbus. This also requires setting P4-06 = 3.			
	1 User PID Reference	This option allows the setpoint to the PID controller to be received from the Fieldbus. In order for this option to be used, P9-38 must be set to 1, and the PID User setpoint must not be utilised within the PLC function.			
	2 User Register 3	The value received by the drive in PDI 3 is transferred to User Register 3. This option allows the function of the process data word to be defined in Parameter Group 9. In this case, User Register 3 should not be written to within any PLC function code, although the value can be read.			

5.2.3. Optidrive P2 / Optidrive Eco - Monitoring Parameters (Read Only)

Par.	Function	Units
P0-07	Fieldbus Speed Reference	Hz / RPM
P0-51	PDI cyclic data	N/A
P0-52	PDO cyclic data	N/A

6. Operation

6.1. Overview

Cyclic control and monitoring of the drive is achieved by a Class 1 connection to the mapped Modbus PDI and PDO parameters. This can be achieved using one of the following methods.

6.2. Configuration

The OPT-2-ETHEG-IN supports the following Ethernet/IP classes:

- 0x01 Identity
- 0x02 Message Router
- 0x06 Connection manager
- 0x45 Modbus Serial
- 0xF4 Port
- 0xF5 TCP/IP
- 0xF6 Ethernet Link.

The OPT-2-ETHEG-IN default IP address is 192.168.1.254, Subnet Mask 255.255.255.0

IP configuration can be changed using:

- The TCP/IP Class 0xF5. Values will not be applied until an Identity Class 0x01 reset is executed.
- Via the internal webserver interface.

6.3. Controlling a Drive via Ethernet/IP

Drive control is achieved by establishing a Class connection using one of the two methods shown below. This allows process data to be cyclically exchanged between the Ethernet/IP master and a connected Optidrive via the OPT-2-ETHEG-IN.

6.3.1. Method 1: Class 1 connection to Drive Assembly object

Drive control can be achieved via Class 1 connections to the Assembly Object (0x04).

The controller must implement the forward open request to the OPT-2-ETHEG-IN Port 3, address 1.

For Drive specific allocation refer to Drive Manual and/or Ethernet/IP EDS file.

For Drive specific read/write limitations refer to Drive Manual and/or Ethernet/IP EDS file.

The following connection setting will establish a Class 1 connection to transfer Drive PDI/PDO Modbus registers:

Connection setting		Value
Path		20 04 24 01 2C 01 2C 06
RPI		Min 50ms
Timeout Multiplier		Recommend x32
Trigger		Cyclic
Transport type		Exclusive owner
O->T	Size	8
	Connection Type	Point to Point
	Length	Fixed
	Transfer Format	32bit Run/Idle
T->O	Size	8
	Connection Type	Point to Point
	Length	Fixed
	Transfer Format	Pure data

6.3.2. Method 2: Class 1 connection via OPC-2-ETHIG-IN 'Forward Open Assembly' object

The OPC-2-ETHIG-IN provides the Vendor Class 'Forward Open Assembly (0x0300)' which negates the need for the control to provide the forward open mapping.

For Drive specific allocation refer to Drive Manual and/or Ethernet/IP EDS file.

For Drive specific read/write limitations refer to Drive Manual and/or Ethernet/IP EDS file.

The following connection setting will establish a Class 1 connection to transfer Drive PDI/PDO registers:

Connection setting		Value
Path		21 00 00 03 24 01 2C 01 2C 06
RPI		Min 50ms
Timeout Multiplier		Recommend x32
Trigger		Cyclic
Transport type		Exclusive owner
O->T	Size	8
	Connection Type	Point to Point
	Length	Fixed
	Transfer Format	32bit Run/Idle
T->O	Size	8
	Connection Type	Point to Point
	Length	Fixed
	Transfer Format	Pure data

6.4. Process Data Exchange

All Optidrives support a 4 word input, 4 word output process data exchange to allow control and monitoring of the drive. The functions and overview of each word are described below.

6.4.1. Process Data Exchange Overview

All Optidrives support a 4 word process data exchange as follows:

- PDI: EIP Master → Drive
 - Word 1: FIXED: Drive Control Word
 - Word 2: FIXED: Frequency/Speed Setpoint
 - Word 3
 - Optidrive E3: FIXED: No Function
 - Optidrive P2/Eco: USER SELECTED Function determined by P5-14
 - Word 4
 - Optidrive E3: FIXED: Ramp Control (When P-12 = 4 only)
 - Optidrive P2/Eco: USER SELECTED Function determined by P5-13
- PDO: Drive → EIP Master
 - Word 1: FIXED: Drive Status
- Low Byte: Drive Status Byte
- High Byte: Trip Code
 - Word 2: FIXED: Output Frequency/Motor Speed
 - Word 3
 - Optidrive E3: FIXED: Output Current
 - Optidrive P2/Eco: USER SELECTED: Function determined by P5-12
 - Word 4
 - Optidrive E3: FIXED: No Function
 - Optidrive P2/Eco: USER SELECTED: Function determined by P5-08

6.5. Process Data PDI

6.5.1. PDI Word 1: Drive Control Word

The drive control word can be used to control the drive as follows:

Port	Function
0	0: Stop 1: Run
1	0: Normal Operation 1: Fast Stop
2	0: No Function 1: Fault Reset Request
3	0: Normal Operation 1: Coast Stop
4	
5	
6	No function
7	

6.5.2. PDI Word 2: Drive Speed Reference

The drive speed reference value has one decimal place, e.g. commanded value = 500, the drive setpoint frequency will be 50.0Hz.

6.5.3. PDI Words 3 and 4

As described in section 6.4.1. Process Data Exchange Overview, process data words 3 and 4 may be fixed function or configurable function depending on the drive in use. The possible functions are described below.

6.5.4. Drive Torque Reference

Where supported by the drive and correctly configured in the drive parameters, the torque limit or reference may also be sent to the drive using the fieldbus PDI. In this case, the value is sent with 1 decimal place, e.g. commanded value = 500, the drive torque setpoint will be 50.0%.

6.5.5. Drive Ramp Times

When the drive parameters are configured to allow control of the drive ramp times through fieldbus, this register specifies the drive acceleration and deceleration ramp times.

- For P2 and Eco drives, when Fieldbus Ramp Control is selected (P5-08 = 1).
- For E3 drives, setting P-12 = 4.

The input data range is from 0 to 60000 (0.00s to 600.00s for P2, 0.0 – 6000.0s for Eco).

6.5.6. User Registers

For P2 and Eco drives, which have internal function block programming capability, data may be written to the User Registers. This allows control functions to be achieved within the drive by linking to the Group 9 parameters. The values may also be used within the function block program.

6.6. Process Data PDO

PDO data is returned from the drive to the master PLC. The available data for each word is described below.

6.6.1. PDO Word 1: Drive Status Word

The function of PDO Word 1 is fixed for all drive models, and returns the drive Status Word. The individual bits within the drive status word indicates the status of the drive as follows. Some functions are applicable to specific drive types, as indicated below.

Bit	Function	E3	P2	Eco
0	0: Drive Disabled (Stopped) 1: Drive Enabled (Running)	✓	✓	✓
1	0: Drive Healthy 1: Drive Tripped	✓	✓	✓
2	0: Auto 1: Hand			✓
3	0: Drive Ready (STO Input Closed) 1: Drive Inhibit (STO Input Option)		✓	✓
4	0: Maintenance Time Not Reached 1: Maintenance Time Reached		✓	✓
5	0: Not In Standby (Sleep) 1: Standby (Sleep) mode active		✓	✓
6	0: Not Ready 1: Drive Ready (Mains Power applied, No Inhibit, No Trip, Enable Input Present)		✓	✓
7	0: No Warning 1: Motor Load Current Outside bandwidth			✓
8 - 15	Fault code number. Refer to the table in section 0.	✓	✓	✓

6.6.2. Drive Fault Codes

The following table provides a list of the possible fault code numbers returned in the Drive Status Word High Byte, and the relevant fault information for each code. Refer to the relevant drive User Guide for further information on the cause and possible solutions for each fault.

No.	Fault Description
00	No fault.
01	Brake channel over current.
02	Brake resistor overload.
03	Instantaneous over current on drive output.
04	Excess load on the motor.
05	Drive has tripped on overload after delivering >100% of value in P1-08 for a period of time.
06	Hardware over current.
07	Over voltage on DC bus.
08	Under voltage on DC bus.
09	Heatsink over temperature.
10	Under temperature.
11	Factory default parameters have been loaded.
12	External trip.
13	Communications fault.
14	Excessive DC Ripple.
15	Input phase loss trip.
16	Instantaneous over current on drive output.
17	Faulty thermistor on heatsink.
18	Internal memory fault.
19	4-20mA signal lost.
20	Internal memory fault.
21	User parameter defaults.
22	Motor PTC over temperature.
23	Cooling fan fault.

24	Ambient temperature too high.
25	Maximum torque limit exceeded.
26	Output torque too low.
29	Drive output fault.
30	Internal STO circuit error.
31	Encoder feedback fault.
32	Speed error.
33	Encoder feedback fault.
34	Encoder feedback fault.
35	Encoder feedback fault.
40	Autotune failed.
41	
42	
43	
44	
45	Input phase sequence incorrect.
49	Output (Motor) phase loss.
50	Modbus comms fault.
51	CAN Open comms trip.
52	Communications option module fault.
53	IO card comms trip.

6.6.3. PDO Word 2: Output Frequency

The function of PDO Word 2 is fixed for all drive models, and returns the drive output frequency in Hz with one decimal place, e.g. returned value = 123, output frequency = 12.3Hz.

6.6.4. PDO Words 3 and 4

As described in section 6.4.1. Process Data Exchange Overview, PDO Words 3 and 4 may be fixed function or configurable function depending on the drive in use. The possible functions are described below.

6.6.5. Output Current

Output current data has one decimal place, e.g. a returned value of 123 indicates output current of 12.3 Amps.

6.6.6. Output Power

Output power data is returned with 2 decimal places, e.g. a returned value of 123 indicates an output power of 1.23kW.

6.6.7. Output Torque

Motor output torque level to one decimal place, e.g. 474 = 47.4%.

6.6.8. Digital Input Status

Displays the status of the drive digital inputs, where Bit 0 = Digital Input 1, Bit 1 = Digital Input 2 etc. A bit value of 1 means the input is ON.

If an external I/O module is connected to the drive, the status of these inputs is displayed in Bits 5 and above.

6.6.9. Analog Input 2 Signal Level

The analog input % signal level after any scaling is applied is returned. The value has 1 decimal place, e.g. a returned value of 123 = 12.3%.

6.6.10. Drive Heatsink Temperature

The value is returned directly in °C with no decimal places, e.g. returned value of 12 = 12°C.

6.6.11. User Register 1 / User Register 2

For P2 and Eco drives, which have internal function block programming capability, data may be read from the User Registers. This allows control functions to be achieved within the drive by linking to the Group 9 parameters. The values may also be used within the function block program.

6.6.12. P0-80 Value

For Optidrive P2 and Eco models, Parameter P0-80 may be used to display internal data from the drive. Refer to the drive documentation for further information.

6.7. OPT-2-ETHEG-IN Web Server

The OPT-2-ETHEG-IN web server interface can be accessed at via the IP address or host name.

- Default IP address: 192.168.1.254
- Hostname: OPCxxxxxxxx, where xxxxxxxx = 'PR ID' value shown on the top product label as described in section 2.2. Labelling.

Both of the above values can be modified via the Web Server or Ethernet/IP Class 0xF4.

The Webserver contains 4 pages as described below.

6.7.1. Module Configuration

Information about the Ethernet IP Interface is displayed. The information is Read Only.

 Module Configuration		Module Identity (Class 0x01)	Network Settings (Class0xF5)	Drive Identity (Class 0x01)
Attribute	Value			
Product Name	OPC-2-ETHIG-IN			
Revision	001.001			
Production Serial Number	59829901003			
ODVA EtherNet/IP Vendor ID	01391			
Product Code	0x0001			
Protocol Serial Number	0x10000004			
MAC Address	70:B3:D5:93:90:04			
Build Data	T:143-A:14212D140142143141-L:93030001			
STATUS				
Data Valid				

6.7.2. Module Identity

Information about the Module Identity (Class 0x01) is displayed. The information is Read Only.

 Module Configuration		Module Identity (Class 0x01)	Network Settings (Class0xF5)	Drive Identity (Class 0x01)
Attribute	Value			
CIP Device ID	00041			
CIP Device Name	Modbus Translator			
CIP Vendor ID	01391			
CIP Product Name	OPC-2-ETHIG-IN			
CIP Product Code	0x0001			
CIP Serial Number	0x10000004			
STATUS				
Data Valid				

6.7.3. Network Settings

The present network settings for the interface are displayed. This data may be changed by the user.

 Module Configuration		Module Identity (Class 0x01)	Network Settings (Class0xF5)	Drive Identity (Class 0x01)
Attribute	Default	Configured	Working Value	Unit
Configuration Method	0	0	0	0:fixed 1:DHCP
DNSEnable	0	0	0	0:disabled 1:enabled
IP Address	192.168.001.253	192.168.001.253	192.168.001.253	IPv4 dotted-decimal
Network Mask	255.255.255.000	255.255.255.000	255.255.255.000	IPv4 dotted-decimal
Gateway Address	192.168.001.200	192.168.001.200	192.168.001.200	IPv4 dotted-decimal
Name Server	000.000.000.000	000.000.000.000	000.000.000.000	IPv4 dotted-decimal
Name Server 2	000.000.000.000	000.000.000.000	000.000.000.000	IPv4 dotted-decimal
Domain Name	"	"		
Host Name	'OPC0268435460'	'OPC0268435462'	OPC0268435462	
Encapsulation Inactivity Timeout	120	120	120	seconds 0:disabled
			Set	
STATUS				
Data Valid				

'Configured' indicated the values currently stored within the module.

'Working Values' indicate the values currently in use (if not yet edited), or the values to be applied. To commit values press 'Set'.

Module will reboot if data is valid, otherwise an error status will be displayed:

Status	
State	Indication
'Data Submitted...'	Data has been submitted to OPT-2-ETHEG-IN, awaiting reply.
'Data Read/Write Error'	An error occurred, data was not stored.
'Resource Busy'	Another operation was accessing the required data for example a Ethernet/IP Class 0xF5 service.
'Invalid request - Data Validation Error'	One or more data value were invalid.
'Data Accepted - Restarting Module at new IP Address...'	Data accepted and stored.

6.7.4. Drive Identity

 Module Configuration		Module Identity (Class 0x01)	Network Settings (Class 0xF5)	Drive Identity (Class 0x01)
Attribute	Value			
CIP Device ID	00040			
CIP Device Name	Modbus Device			
Modbus Vendor Name	Inverter Drives Ltd			
Modbus Product Code	OptiDrive			
Modbus Version Number	1.10			
	Refresh			
STATUS				
Data Valid				

Data is read from the Drive.

If the Drive does not support this functionality then the following data is required:

- Vendor Name: 'Unknown Modbus Device'
- Product Code: Empty
- Version Number: Empty.

6.8. Drive parameter access

6.8.1. Overview

The OPT-2-ETHEG-IN is a Modbus translator device. This means that all data accessible from the drives Modbus RTU interface may also be accessed via the Ethernet/IP interface.

For details of the relevant Modbus registers available for each drive, refer to the drive documentation.

6.8.2. Supported Ethernet/IP Classes

The OPT-2-ETHEG-IN supports the following Ethernet/IP classes to allow communication with a connected Drive:

- 0x01 Identity
- 0x02 Message Router
- 0x04 Assembly
- 0x06 Connection manager
- 0x0F Parameter
- 0x44 Modbus.

Drive parameters may be accessed using unconnected or Class 2/3 connection via following methods:

Status LED	Function	
0x0F Parameter	0x0E Get_Attribute_Single	Individual parameter Read/Write Instance 1 = holding register 0
	0x10 Set_Attribute_Single	
0x44 Modbus Object	0x4E Read_Holding_Registers	Multiple parameter Read/Write Instance 1 = holding register 0
	0x50 Write_Holding_Registers	
0x04 Assembly Object	0x18 Get_Member	
	0x19 Set_Member	

NOTE

All Optidrive support the following Modbus RTU Commands:

- 0x03 Read Multiple Holding Registers.
- 0x06 Write Single Holding Register.

Sequential blocks of available Modbus Registers may be read either by using multiple 0x0E Get_Attribute_Single commands or by using a single 0x4E Read_Holding_Registers to read multiple register values in a single command.

In order to write parameter values to the drive, each individual parameter must be written in a singularly, either using 0x10 Set_Attribute_Single or 0x50 Write_Holding_Registers. It is not possible to write multiple parameters in a single command.

6.9. Working with Rockwell Automation RSLogix5000

This section describes how to configure a Rockwell Automation RSLogix5000 project to connect to an Optidrive via the OPT-2-ETHEG-IN.

NOTE At present Rockwell Automation RSLogix5000 does fully not support the CIP Modbus Translator specification, due to this Optidrives will only appear within the RSLogix5000 Project as an OPT-2-ETHEG-IN CIP Modbus Translator Device.

When integrating the OPT-2-ETHEG-IN into a Rockwell Automation RSLogix5000 project, the following steps are required.

6.9.1. Add the EDS file

- From RSLogix5000 'Tools->EDS Hardware Installation Tool'.
- When the tool loads, press 'Next'.
- When prompted select 'Register an EDS File(s)' and press 'Next'.
- Select 'Register a single file', press 'Browse', navigate to and select the 'OPT-2-ETHEG-IN.eds' file.
- Press 'Next' and allow installation to complete.

At present only the OPT-2-ETHEG-IN EDS file is required. Individual Optidrive EDS files may be provided for mapping details, but are not currently supported by RSLogix5000 and therefore should not be loaded using the 'EDS Hardware Installation Tool'.

6.9.2. Configure the IP Address

Configure the OPT-2-ETHEG-IN IP address using either the OPT-2-ETHEG-IN Web Server (see section 6.7.3. Network Settings) or using RSLinx as follows:

- Launch RSWho from RSLinx 'Communications->Who Active'.
- From within the 'RSWho' window, select and expand the required path.
- Right click on the OPT-2-ETHEG-IN device to be updated and select 'Module Configuration'.
- In the Configuration tab, update the Network Setting as required and press 'Apply'.
- Confirm the changes when prompted.
- Power cycle the OPT-2-ETHEG-IN device.
- Confirm the parameters selecting and refreshing path.

Alternatively, for a new module leave at default values and update using RSLogix 5000 once the network is established.

6.9.3. Add Device to RSLogix5000 project

- Under "I/O Configuration" right click on "Ethernet" to specify a "New Module".
- Select 'OPT-2-ETHEG-IN' and then click "Create" [Note, the OPT-2-ETHEG-IN can be found under Vendor filter 'Invertek Drives' or Device type filter 'CIP Modbus Translator'].
- Give a name and enter the required IP address then click "OK".
- The OPT-2-ETHEG-IN tags and Class 1 connection for Drive PDI/PDO will now be available, and the data is available for your user program.

6.9.4. Test connection

- Download project to PLC.
- Under "I/O Configuration" double click in the OPT-2-ETHEG-IN.
- Under the 'Connection' tab, confirm Status = Running.

7. Technical Data

7.1. Environmental

Ambient Temperature	Storage and Transportation	-40 ... 60°C / -40 ... 140°F	
	Operating	-10 ... 50°C / 14 ... 122°F	UL approved
		40 ... 50°C / 104 ... 122°F	Without UL approval
Maximum Altitude	Operating	≤1000m	UL approved
		≤4000m	Without UL approval
Relative Humidity	Operating	< 95%	Non-condensing, frost and moisture free

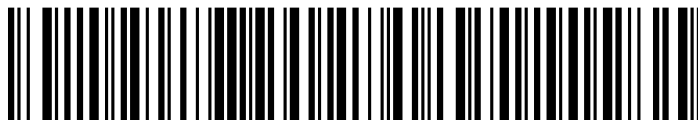

82-EIPMN-IN_V1.10

Invertek Drives Ltd. Offa's Dyke Business Park, Welshpool, Powys SY21 8JF United Kingdom
Tel: +44 (0)1938 556868 Fax: +44 (0)1938 556869
www.invertekdrives.com



SCATTERGOOD & JOHNSON LTD

ELECTRICAL ENGINEERING & FLUID CONTROL DISTRIBUTORS

Est.1899

At Scattergood & Johnson Ltd, we pride ourselves on being a technical distributor to specialist industries.

Working with a range of quality product suppliers across a number of specialist markets, we are not your average 'box shifter' - we are your technical and supply chain partner.

We fully support every product we sell - for free! Our internal team and external sales engineers can answer any product or application question, no matter the complexity.

Backing up this technical ability is a range of 50,000+ products available from stock for nationwide next day delivery (same day if required!), or you can collect what you need from any of our trade counters around the UK.

Select your specialist interest below to learn more about how we can help.

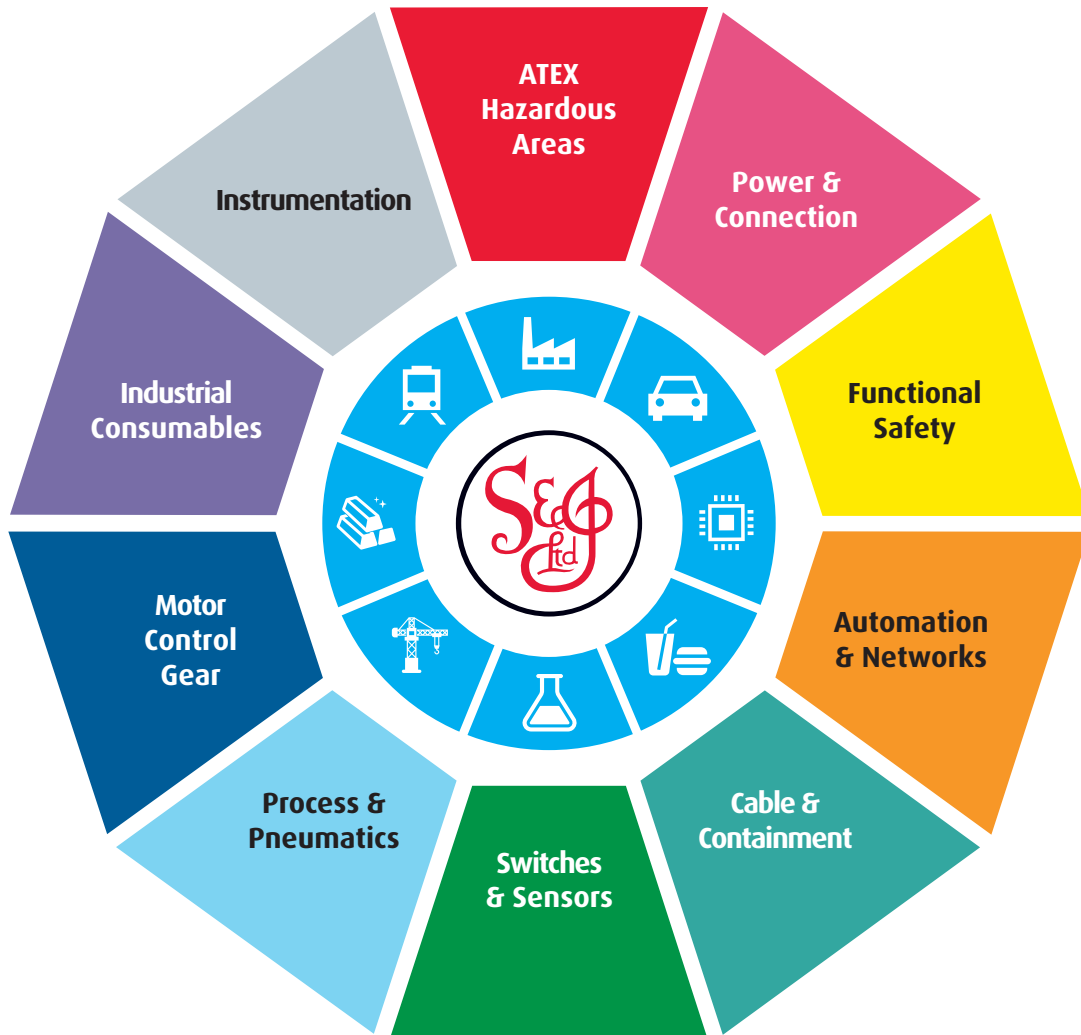

Online, In Branch and On the Road - Scattergood & Johnson Ltd, there when you need us.

www.scatts.co.uk