

# OPTIPOINT 2

Remote Keypad Option Module

## User Guide

Installation and Operating Instructions



### DECLARATION

All rights reserved. No part of this User Guide may be reproduced or transmitted in any form or by any means, electrical or mechanical including photocopying, recording or by any information storage or retrieval system without permission in writing from the publisher.

Copyright Invertek Drives Ltd © 2010

The manufacturer accepts no liability for any consequences resulting from inappropriate, negligent or incorrect installation, or adjustment of the optional operating parameters of the drive or from mismatching of the drive to the motor.

The contents of this User Guide are believed to be correct at the time of printing. In the interests of a commitment to a policy of continuous improvement, the manufacturer reserves the right to change the specification of the product or its performance or the contents of the User Guide without notice.

### WARRANTY

All Invertek Drives Ltd (IDL) products carry a 2-year warranty, valid from the date of manufacture. This date is clearly visible on the rating label.

Complete Warranty Terms and Conditions are available upon request to your IDL Authorized Distributor.

**INVERTEK DRIVES LTD**  
**Offa's Dyke Business park**  
**Welshpool**  
**Powys**  
**SY21 8JF**  
**UK**

Tel +44 (0) 1938 556868  
 Fax +44 (0) 1938 556869  
 Internet www.invertek.co.uk

Part No. 82-OPT-2-OPOINT-IN V 1.00 December 2010

### SAFETY

Optipoint 2 is designed to be used in conjunction with the Optidrive variable speed drive ranges listed. It is intended for professional incorporation into complete equipment or systems. The Optipoint 2 can be used to control the operation of the Optidrive ranges ODE-2, ODP-2 and ODV-2 (hereafter referred to as Optidrive). The drive must be installed correctly to prevent a safety hazard. The Optidrive uses high voltages and currents, carries a high level of stored electrical energy, and is used to control mechanical plant that may cause injury. Close attention is required to system design and electrical installation to avoid hazards in either normal operation or in the event of equipment malfunction.

System design, installation, commissioning and maintenance must be carried out only by personnel who have the necessary training and experience. They must read carefully this safety information and the instructions in this and the Optidrive User Guides and follow all information regarding transport, storage, installation and use, including the specified environmental limitations.

Please read the **IMPORTANT SAFETY INFORMATION** below, and all **Warning** and **Caution** boxes within this document.

### SAFETY NOTICES

**WARNING** is given where there is a hazard that could lead to injury or death of personnel.  
**CAUTION** is given where there is a hazard that could lead to damage to equipment.

### IMPORTANT SAFETY INFORMATION

#### Safety of machinery, and safety-critical applications

The level of integrity offered by the Optipoint 2 / Optidrive control functions – for example stop/start, forward/reverse and maximum speed, is not sufficient for use in safety-critical applications without independent means of protection. All applications where malfunction could cause injury or loss of life must be subject to a risk assessment and further protection provided where needed.

Within the European Union, all machinery in which this product is used must comply with Directive 89/392/EEC, Safety of Machinery. In particular, the electrical equipment should comply with EN60204-1.

### CONFORMITY WITH STANDARDS FOR OPTIDRIVE

- CE-marked for Low Voltage Directive.
- EN61000-4 EMC Generic Emissions Standard, Industrial Level.
- EN61000-2 EMC Generic Immunity Standard, Industrial Level.
- Enclosure ingress protection, EN60529, NEMA 250.
- Flammability rating according to UL 94.

### GENERAL SPECIFICATION

Compatible Drives: Optidrive ODE-2, ODP-2, and ODV-2  
 Signal Interface: Standard 6-way RJ45 connector  
 Supply Input: 10V ... 36V DC, 30mA  
 RS485 signal: Industry standard 2-wire +5V differential  
 Environmental: Operational: 0 ... 50 °C  
 Storage: -40 °C ... 60 °C  
 Relative Humidity < 95% (non condensing)  
 Protection rating: IP54  
 Max cable length: 20m (unscreened, total length)  
 100m (screened, twisted pair, total length)

### MECHANICAL INSTALLATION

#### WARNING

- When installing the Optipoint 2, all Optidrives should be disconnected and **ISOLATED** before attempting any work. High voltages are present at the terminals and within the drive for up to 10 minutes after disconnection of the electrical supply. The Optidrives should be installed by qualified electrical persons and in accordance with local and national regulations and codes of practice.
- Refer to the relevant Optidrive user manual for further details.

#### CAUTION

- Carefully inspect the Optipoint before installation to ensure it is undamaged.
- Store the Optipoint in its box until required. Storage should be clean and dry. Temperature range -40°C to +60°C.
- Install the Optipoint on a flat, flame-resistant vibration-free surface.
- Flammable material should not be placed close to the Optipoint.

### DIMENSIONS

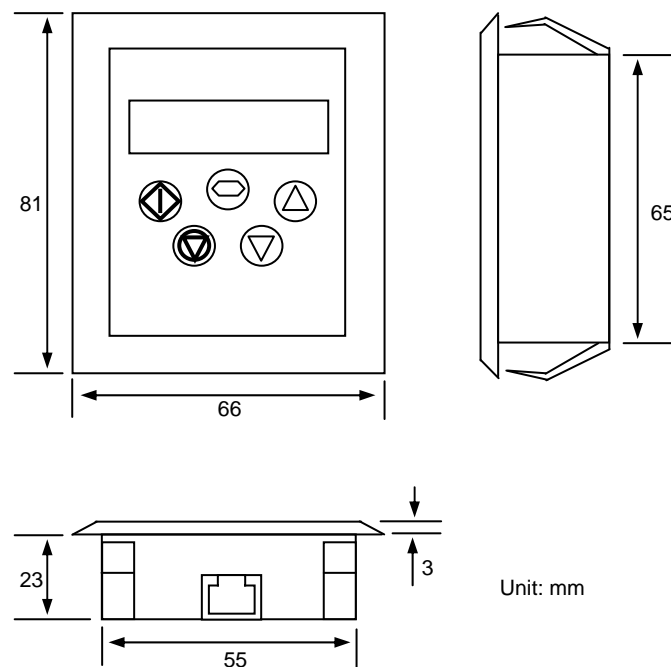

### THROUGH PANEL MOUNT

The panel on to which the Optipoint 2 is to be mounted should be cut out in accordance with the diagram below.

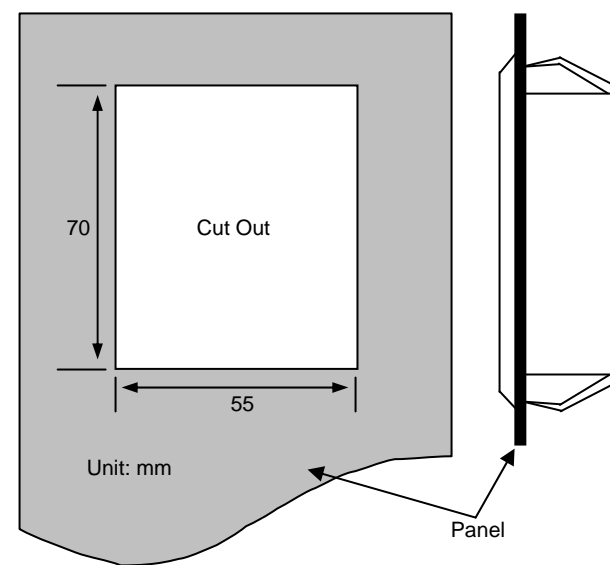

### ELECTRICAL INSTALLATION

#### Electrical Interface

The Optipoint 2 uses a standard RJ45 8-Way connector as its electrical interface, which provides a simple solution for the user to setup their system using a standard RJ45 8-Way data cable. The signal layout of the connector is as follows:

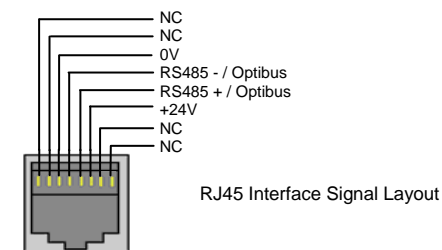

RJ45 Interface Signal Layout

#### Cable Requirements

Standard 8-way data cables with plugs are available from your local Invertek Drives stockist on request. If the data cable is made up on site, ensure that the connection pin out is correct: Pin 1 to Pin 1, through Pin 8 to Pin 8.

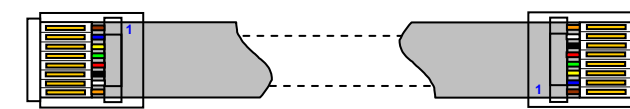

8-way ribbon cable with Header

#### CAUTION

Incorrect cable connection may damage the drive. Extra care should be taken when using third party cable.

#### System Setup

The Optidrive provides the +24V power supply to the Optipoint 2 via the RJ45 connection. Once the physical connection has been setup, the system is ready to operate. See picture below:  
 Note: The location of the RJ45 connector on the Optidrive will vary depending on the Optidrive range and model.

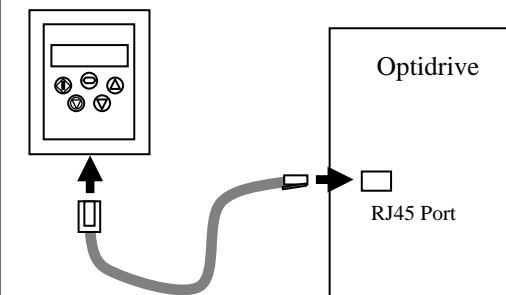

### Electromagnetic Compatibility (EMC)

Optidrive is designed to high standards of EMC. EMC data is provided in a separate EMC Data Sheet, available on request. Under extreme conditions, the product might cause or suffer disturbance due to electromagnetic interaction with other equipment. It is the responsibility of the installer to ensure that the equipment or system into which the product is incorporated complies with the EMC legislation of the country of use. Within the European Union, equipment into which this product is incorporated must comply with 89/336/EEC, Electromagnetic Compatibility.

When installed as recommended in the User Guide, the radiated emissions levels of all Optidrives are less than those defined in the Generic radiated emissions standard EN61000-6-4. The conducted emission levels are less than those defined in the Generic radiated emissions standard EN61000-6-4 (class A) for the specified motor cable lengths.

### USER INTERFACE

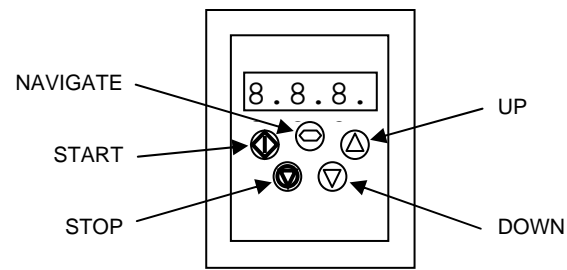

**NAVIGATE:**  
Used to display real-time information, to access and exit parameter edit mode and to store parameter changes

**UP:**  
Used to increase speed in real-time mode or to increase parameter values in parameter edit mode

**DOWN:**  
Used to decrease speed in real-time mode or to decrease parameter values in parameter edit mode

**RESET / STOP:**  
When drive is in trip mode, this button is used to reset a tripped drive. In normal application, when in Keypad mode, this button is used to stop the drive when enabled and running.

**START:**  
When in keypad mode, the button is used to start a stopped drive or to reverse the direction of rotation if bi-directional keypad mode is enabled (See drive user guide for more information).

### SYSTEM SETUP

Depending on the requirement of the application, Optiport 2 can be used in the following different ways:

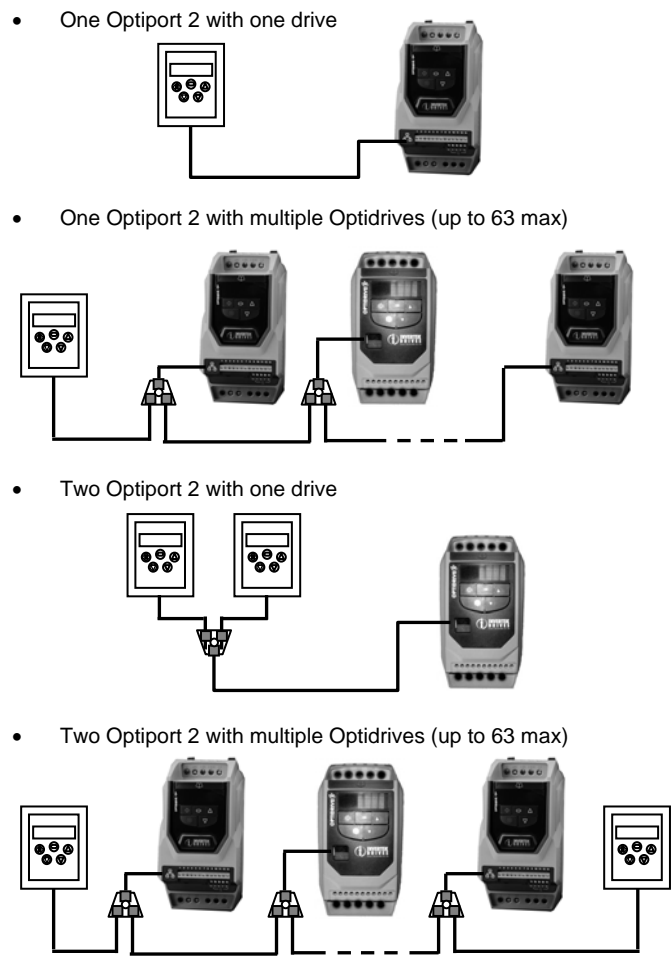

Different drive models can be used on the same Optiport 2 network provided a unique communications address is assigned to each.

**Note:** Cable splitter available from Invertek Drives Ltd on request.

### EASY STARTUP

#### To setup the communication address

By default, the Optiport 2 will try to communicate with the drive that has address 1 in the network after powering up for the first time.

The Optiport 2 will display "SCAN.." after power up, which indicates that the Optiport 2 is searching for the drive with the correct drive address in the network. Once the drive has been found, the message "Load.." will be displayed on the Optiport display window, which indicates that the Optiport is reading the configuration information from the drive. Usually it will take 1-2 seconds for the Optiport to read this information. After the data has been loaded, Optiport 2 will display the drive real time status.

If the Optiport 2 doesn't find the drive in the network, i.e. there is no drive in the network with address equal to 1, the Optiport 2 communication address will be displayed on the monitor window as "Adr-01". The user can then adjust the address from 1 to 63 by using the UP or DOWN buttons on the Optiport 2.

Once the address has been changed to a value to match that of the drive, the STOP button must be pressed to enable the Optiport 2 to search for the drive again.

Once the communication between Optiport and drive has been set up, The user can change the Optiport address to set up communication with another drive in the same drive network at anytime.

Pressing the STOP and DOWN buttons together results in the message "Adr-XX", where "XX" represents the present address. Using the UP or DOWN button to select the desired drive address. After selecting the new address, pressing STOP and DOWN button together again will result in Optiport 2 establishing communications with the drive that has this address.

#### NOTE

For detailed parameter listing and functional setup, please refer to the corresponding Optidrive user guide

#### To setup Optiport 2 device number

The user can use a maximum of 2 Optiport 2 units within the same drive network to communicate with the same drive or different drives.

When using two Optiport 2 units with the same drive, the user needs to change the Optiport 2 Device Number on the second Optiport 2 to ensure correct operation. All Optiport 2 units are set to Device Number 1 by default.

To change the Device Number, press the NAVIGATE, STOP and DOWN buttons together. The message "Port-X" (x = 1 or 2) will be displayed. The User can then use the UP or DOWN buttons to change the Optiport 2 Device Number to 1 or 2 as required. Press NAVIGATE, STOP and DOWN button together again to return to normal operation.

#### Note:

- Once the User has set the Optiport 2 as Device Number 2, Optistore or OptiTools software cannot be used on the same drive network.
- The Optiport 2 Device Address should only be changed to 2 if 2 Optiport 2 units are connected on a network. An Optiport 2 with Device Number 1 must always be present for the network to function correctly.

### REAL TIME OPERATION

Once the communication has been setup between the drive and Optiport 2, the user can control the Optidrive by using the control buttons on the front panel of the Optiport 2.

#### To monitor or change a parameter value

- Press and hold the NAVIGATE key for more than 1s when the drive is displaying "StoP". The display changes to the first parameter in the Optidrive parameter menu.
- Press and release the NAVIGATE key to display the value of the parameter to be edited.
- Change to the required value using the UP and DOWN keys.
- Press and release the NAVIGATE key once more to store the change.
- Press and hold the NAVIGATE key for more than 1s to return to real-time mode. The display shows "StoP" if the drive is stopped or the real-time information (e.g. speed, current or power) if the drive is running.

#### To change parameter group (ODP-2 & ODV-2 drives only)

Ensure that extended parameter group access is enabled. The default extended parameter access code is 101 and this should be entered in P1-14 to enable the extended parameter group access. Enter parameter edit mode with parameter number PX-XX displayed. Press NAVIGATE button and then simultaneously press and release the UP or DOWN key to change the parameter group number until the required parameter group is displayed.

#### Locking access to the parameters

- To prevent unauthorised access to the parameters via the Optiport 2, set the following parameter values based on the Optidrive product range in use:

ODP-2 or ODV-2 Range: P2-38 = 1

ODE-2 Range: P-38 = 1

Once this parameter has been set, access to parameters via the Optiport 2 will be prevented.

- The operational information (e.g. speed, current, power etc) can be still accessed as normal and the drive can still be controlled from the keypad.

- To unlock parameter access, change parameter listed above back to 0 via the drive keypad directly.

#### Presetting target speed in keypad mode

Set the following parameter values based on the Optidrive product range in use:

ODP-2 or ODV-2 Range: P1-12 = 1 or 2

ODE-2 Range: P-12 = 1 or 2

Setting a value of 1 enables keypad mode with forward direction only, whilst a value of 2 enables keypad mode with forward and reverse rotation.

Ensure the following parameters are also set based on the Optidrive product range in use to enable the drive to start from the preset speed:

ODP-2 or ODV-2 Range: P2-19 = 1 or 3

ODE-2 Range: P-31 = 1 or 3

Whilst the drive is stopped, press the STOP key. The value of the digital potentiometer will be displayed, indicating target speed. Use the UP and DOWN keys to select the required target speed.

Press the STOP key to return to the real time display showing "StoP", or the START key to start the drive ramping up to the target speed.

#### To vary the speed in real time in keypad control mode

Press the START key. The drive will ramp up to the preset speed set in the digital potentiometer (assuming P2-19 / P-31 = 1).

Press UP to increase speed.

The drive will run forward, increasing speed until the UP button is released. The maximum speed is the speed set in:

ODP-2 or ODV-2 Range: P1-01

ODE-2 Range: P-01

Press DOWN to decrease speed.

The drive will decrease speed until the STOP button is released. The minimum speed is the speed set in:

ODP-2 or ODV-2 Range: P1-02

ODE-2 Range: P-02

Press the STOP key to stop the drive.

The drive will decelerate to stop at the selected deceleration ramp.

The display will finally show "StoP" at which point the drive is disabled.

Pressing the START key once more results in the drive running back up to the speed at which it was previously running (assuming P2-19 / P-31 = 1).

#### To reverse direction of rotation with P1-12 = 2

Set the following parameter values based on the Optidrive product range in use to select keypad mode with reverse direction enabled:

ODP-2 or ODV-2 Range: P1-12 = 2

ODE-2 Range: P-12 = 2

Press the START key. The drive ramps up to the preset speed as set in the digital potentiometer (assuming P2-19 / P-31 = 1).

Press UP or DOWN to increase or decrease the speed.

Press the START key again. The motor will reverse its direction of rotation.

Press the STOP key to decelerate the motor to standstill. Whenever the drive is started, it will start with a positive speed unless the direction is negated by the digital inputs on the user terminals.

### BASIC DRIVE TRIP CODES

For a full list of codes and detailed troubleshooting information please refer to the corresponding Optidrive user manual

Fault Code ODE-2	Fault Code ODP-2 & ODV-2	What has happened
P-dEF	P-dEF	Default parameters loaded
Q-i	E-Qi E-hQi	Over current on drive output to motor
I-t-EP	E-I.tEF	Drive overload trip.
Ql-b	E-brQi	Brake channel over current
Ql-br	E-brQl	Brake resistor overload
P5-EP	E-P5	Internal power stage fault
U-ULt	E-UU	Over voltage on DC bus
U-ULt	E-UU	Under voltage on DC bus
Q-t	E-Qt	Heatsink over temperature
U-t	E-Ut	Under temperature
th-FLt	E-thF	Faulty thermistor on heatsink.
E-EP iP	E-Et	External trip on digital Input
SC-EP	E-SC IQ	Comms loss trip
P-LQ55	E-PLQ5	Input phase loss trip
SPi n-F	SP in-F	Spin start failed
dRtR-F	E-dRtF	Internal memory fault. Parameters not saved, defaults reloaded.
4-2Q F	E-4.2QF	Current analog input out of range
N/A	Ph-i b	Three phase input voltage imbalance
N/A	E-Rt_	Auto-tune failed error with error code

### UNDERSTANDING THE DISPLAY MESSAGES

Optiport 2 uses various display messages to indicate different working status. See the following table for more information.

Message	Explanation
SCAN..	The Optiport 2 is searching for the drive in the network.
LOAD..	The Optiport 2 has found the drive in the network and is loading the initialisation information from the drive.
Err-SC	The Optiport 2 has lost the communication link to the drive.
Adr-XX	Indicates the Optiport 2 address, where XX= 1...63
Port-X	This message shows the Optiport 2 device number X = 1 or 2

### TROUBLE SHOOTING

Symptom	Explanation
'Adr-XX' displayed after 'SCAN..' message	Optiport 2 failed to find the drive with the specified address in the network. Check that the RJ45 data cable connection is correct. Check that the drive with address XX is available in the network.
Display 'Err-id' on power up	This normally occurs when there are two Optiport 2 units in the same drive network and both of them have the same device number. Check and change the device number of one Optiport 2.
Display 'Err-id' during normal operation	This normally occurs when the user plugs a second Optiport 2 into the drive network. Change the device number of one of the Optiport 2 units.
Display 'Err-SC'	Check the electrical connection, and make sure the cable is connected correctly between the Optiport 2 and the drive. Press 'STOP' button to enable the Optiport 2 to search for the drive again.



Invertek Drives Ltd adopts a policy of continuous improvement and whilst every effort has been made to provide accurate and up to date information, the information contained in this brochure should be used for guidance purposes only and does not form the part of any contract.



# SCATTERGOOD & JOHNSON LTD

ELECTRICAL ENGINEERING & FLUID CONTROL DISTRIBUTORS

Est.1899

At Scattergood & Johnson Ltd, we pride ourselves on being a technical distributor to specialist industries.

Working with a range of quality product suppliers across a number of specialist markets, we are not your average 'box shifter' - we are your technical and supply chain partner.

We fully support every product we sell - for free! Our internal team and external sales engineers can answer any product or application question, no matter the complexity.

Backing up this technical ability is a range of 50,000+ products available from stock for nationwide next day delivery (same day if required!), or you can collect what you need from any of our trade counters around the UK.

Select your specialist interest below to learn more about how we can help.



Online, In Branch and On the Road - Scattergood & Johnson Ltd, there when you need us.

# [www.scatts.co.uk](http://www.scatts.co.uk)