

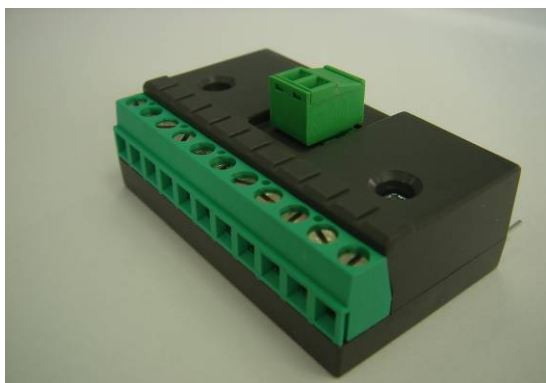

OPTIDRIVE HVAC RELAY OPTION MODULE



SAFETY NOTICES

WARNING is given where there is a hazard that could lead to injury or death of personnel.

CAUTION is given where there is a hazard that could lead to damage to equipment.

It is the responsibility of the installer to ensure that the equipment or system into which the product is incorporated complies with the EMC legislation of the country of use. Within the European Union, equipment into which this product is incorporated must comply with 89/336/EEC, Electromagnetic Compatibility.

CAUTION

- Store the Option in its box until required. It should be stored in a clean and dry environment. Temperature range -40°C to $+60^{\circ}\text{C}$.

- Install the Option onto the Optidrive by inserting the row of 11 pins into the terminal connector of the Optidrive, ensuring that the terminals are tightened.

- If the Option is being used with Size#1 Optidrive, care should be taken to support the Option when the terminal screws of the Option are being tightened or loosened.

WARNING

Within the European Union, all machinery in which this product is used must comply with the Directive 89/392/EEC, Safety of Machinery. In particular, the equipment should comply with EN60204-1.

WARRANTY

Complete Warranty Terms and Conditions are available upon request from your IDL Authorised Distributor.

WARNING

- Optidrives and the Options should be installed only by qualified electrical persons and in accordance with local and national regulations and codes of practice.

- **Electric shock hazard!** Disconnect and **ISOLATE** the Optidrive before attempting any work on it. High voltages are present at the terminals and within the drive for up to 10 minutes after disconnection of the electrical supply.

- Where the electrical supply to the drive is through a plug and socket connector, do not disconnect until 10 minutes have elapsed after turning off the supply.

User Guide

All rights reserved. No part of this User Guide may be reproduced or transmitted in any form or by any means, electrical or mechanical including photocopying, recording or by any information storage or retrieval system without permission in writing from the publisher.

Copyright Invertek Drives Ltd ©2005

The manufacturer accepts no liability for any consequences resulting from inappropriate, negligent or incorrect installation.

The contents of this User Guide are believed to be correct at the time of printing. In the interests of a commitment to a policy of continuous improvement, the manufacturer reserves the right to change the specification of the product or its performance or the contents of the User Guide without notice.

SAFETY

This option is specifically designed to be used with the Optidrive variable speed drive product and is intended for professional incorporation into complete equipment or systems. If installed incorrectly it may present a safety hazard. The Optidrive uses high voltages and currents, carries a high level of stored electrical energy, and is used to control mechanical plant that may cause injury. Close attention is required to system design and electrical installation to avoid hazards in either normal operation or in the event of equipment malfunction.

System design, installation, commissioning and maintenance must be carried out only by personnel who have the necessary training and experience. They must read carefully this safety information and the instructions in this Guide and follow all information regarding transport, storage, installation and use of the Option module, including the specified environmental limitations.

Please read the IMPORTANT SAFETY INFORMATION below, and all Warning and Caution boxes elsewhere.

STANDARDS CONFORMITY

An Optidrive fitted with this Option complies with the following standards:

- CE-marked for Low Voltage Directive.
- IEC 664-1 Insulation Coordination within Low Voltage Systems.
- UL 840 Insulation Coordination for electrical equipment.
- EN50081-2 EMC Generic Emissions Standard, Industrial Level.
- EN50082-2 EMC Generic Immunity Standard, Industrial Level.
- Enclosure ingress protection, EN60529 IP00, NEMA 250.
- Flammability rating according to UL 94.

Invertek Drives Ltd
Offa's Dyke Business Park
Welshpool
Powys
SY21 8JF
UK

Tel: +44 (0) 1938 556868
Fax: +44 (0) 1938 556 869

email: enquiry@invertek.co.uk
Internet: www.invertek.co.uk

Part No. 82-HVACO-IN
Iss 1.00

EXPLANATION

The HVAC Relay Option Module can be used in applications where two indicators are required showing “drive running” and “drive tripped”.

Product Suitability

There are 2 variants of this option. The correct variant must be used with the following products:

- Optidrive** **OD-HVACO-IN**
- Optidrive E** **ODE-HVACO-IN**

SPECIFICATIONS

Max Relay switching voltage:
250V AC / 220V DC

Max Relay switching current: 1A
Max input voltage : +/- 50V DC
Environmental : -10°C ... +50°C
Conformity : IP00, UL94V-0

OPTION COMPONENT LAYOUT

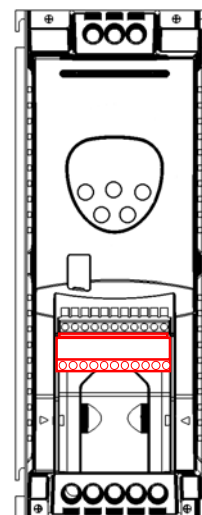
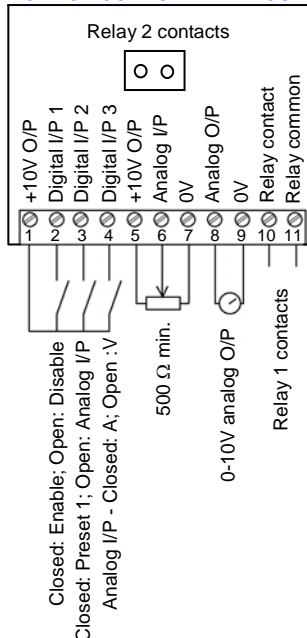

Optidrive size 2

Option PCB inserted into Optidrive control terminal strip.

All 11 terminal screws on the Optidrive must be tightened to ensure good electrical contact and correct functionality.

OPERATION

Programming the first relay output

For typical operation set P-18 = 1, eg Relay 2 closed on enable (Drive running – Green Light), Relay 1 closed when drive tripped (Red Light).

Use the following information to set P-18 for other types of Relay output:
Since the first relay output (fitted within the Optidrive) is programmed using P-18 in the Optidrive, two completely independent relay outputs are available. The following options are supported for Relay 1 :

- P-18 = 0 Relay 1 closed when Optidrive disabled
- P-18 = 1 Relay 1 closed when Optidrive tripped
- P-18 = 2 Relay 1 closed when Optidrive output not at set (requested) speed
- P-18 = 3 Relay 1 closed when Optidrive output is at zero speed
- P-18 = 4 Relay 1 closed when Optidrive output is not at maximum speed
- P-18 = 5 Relay 1 closed when Optidrive output is not in overload

Programming the second relay output

The second relay output has only one practical setting -
When P-18 = 1, Relay 2 is closed when Optidrive is running

OPTION MODULE CONTROL TERMINALS

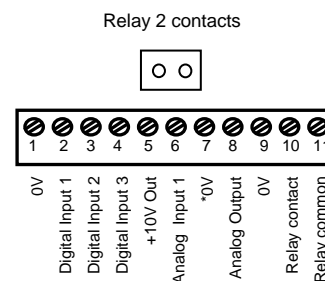

* Analog inputs should be connected to terminals 6 & 7.

NOTES





SCATTERGOOD & JOHNSON LTD

ELECTRICAL ENGINEERING & FLUID CONTROL DISTRIBUTORS

Est.1899

At Scattergood & Johnson Ltd, we pride ourselves on being a technical distributor to specialist industries.

Working with a range of quality product suppliers across a number of specialist markets, we are not your average 'box shifter' - we are your technical and supply chain partner.

We fully support every product we sell - for free! Our internal team and external sales engineers can answer any product or application question, no matter the complexity.

Backing up this technical ability is a range of 50,000+ products available from stock for nationwide next day delivery (same day if required!), or you can collect what you need from any of our trade counters around the UK.

Select your specialist interest below to learn more about how we can help.



Online, In Branch and On the Road - Scattergood & Johnson Ltd, there when you need us.

www.scatts.co.uk