



Model Number

ML29-P/25/103/143

Thru-beam sensor
4-pin plastic connector, 6.5 mm diameter

Features

- Single-beam monitoring with extremely narrow sensor
- Integrated circuit
- Test
- Simple installation - Plug & Play
- Ideal for installation in door profiles or frames
- Light on version

Product information

The narrow miniature thru-beam sensors are a small and cost-effective solution, fitting in virtually any door frame. The ML29 and ML30 series offer fast, reliable detection at a distance of up to 8.5 m. The sensors are easy to mount on the profile, either using adhesive strips or a screw. A large opening angle ensures problem-free alignment. Several sensors can be mounted in a cross formation to offer multi-beam protection.

Release date: 2019-12-18 11:18 Date of issue: 2019-12-18 129312_eng.xml

Dimensions

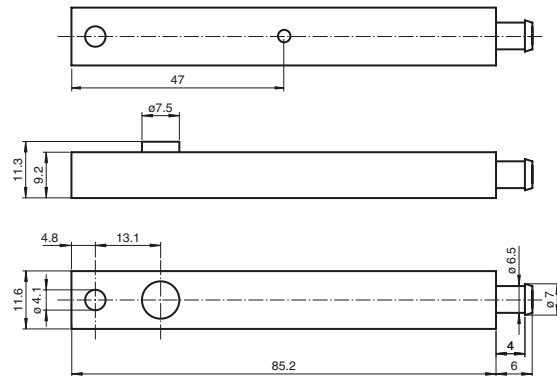

Electrical connection

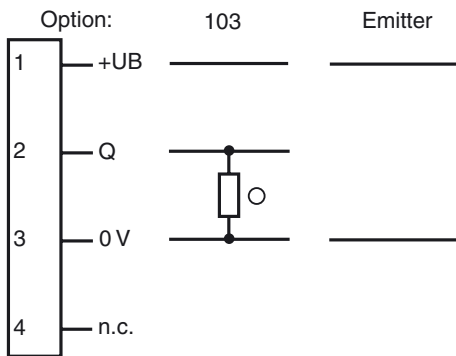

○ = Light on
● = Dark on

Pinout

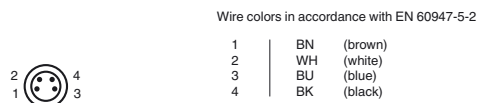

Indicators/operating means

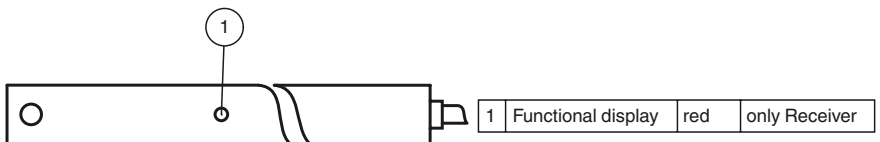

Technical data

System components

Emitter	ML29-T/143
Receiver	ML29-R/25/103/143

General specifications

Effective detection range	0 ... 6 m
Threshold detection range	8.5 m
Light source	IREL
Light type	modulated infrared light
Angle of divergence	+/- 8 °
Optical face	lateral
Ambient light limit	40000 Lux

Functional safety related parameters

MTTF _d	880 a
Mission Time (T _M)	20 a
Diagnostic Coverage (DC)	0 %

Indicators/operating means

Function indicator	LED red in receiver : lights up when receiving the light beam
--------------------	---

Electrical specifications

Operating voltage	U _B	11 ... 30 V DC
No-load supply current	I ₀	Emitter: ≤ 25 mA Receiver: ≤ 10 mA

Input

Test input	Test: Transmitter switches off at +U _B ≤ 5 V DC
------------	--

Output

Switching type	light on	
Signal output	1 PNP output, short-circuit protected, reverse polarity protected, open collector	
Switching voltage	max. 30 V DC	
Switching current	max. 0.1 A	
Switching frequency	f	100 Hz
Response time	5 ms	

Conformity

Product standard	EN 60947-5-2
------------------	--------------

Ambient conditions

Ambient temperature	-20 ... 60 °C (-4 ... 140 °F)
Storage temperature	-20 ... 75 °C (-4 ... 167 °F)
Relative humidity	90 % , noncondensing

Mechanical specifications

Degree of protection	IP65
Connection	4-pin plastic connector, 6.5 mm diameter
Material	
Housing	PMMA , black
Optical face	Plastic pane
Mass	per device 120 g

Compliance with standards and directives

Standard conformity	
Standards	EN 61000-6-2, EN 61000-6-3

Approvals and certificates

CCC approval	CCC approval / marking not required for products rated ≤36 V
--------------	--

Curves/Diagrams

Characteristic response curve

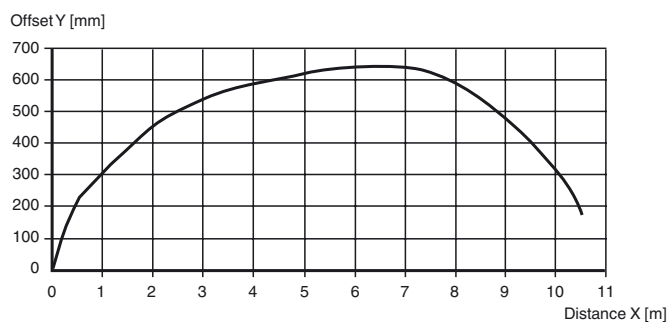

Typical applications

- Person detection for automatic doors and gates
- Closing edge protection on sliding and revolving doors
- Threshold monitoring for elevator doors
- Step monitoring for doors on public transport vehicles
- Trigger function for restarting escalators

Detection area

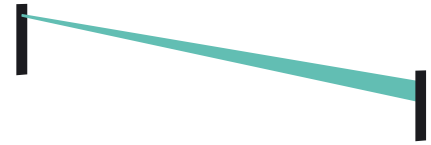

Accessories

ML29 Front Plate

Front plate for thru-beam sensors in series ML29

ML29 Kupplungsdose 6m 4polig

Female cordset with 6 m cable for ML29 series sensors

ML29 Kupplungsdose 3m 4polig

Female cordset with 3 m cable for ML29 series sensors

Other suitable accessories can be found at www.pepperl-fuchs.com

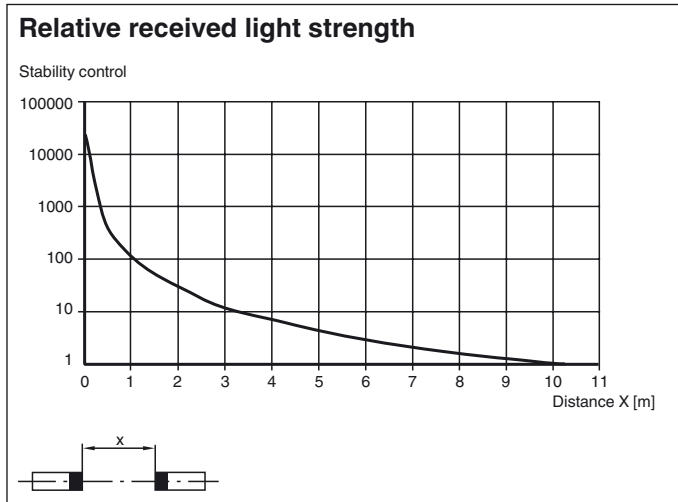

Function principle

The thru-beam sensor requires a pair of devices for operation, comprising a light transmitter and a light receiver. The emitter and receiver must be arranged in optical alignment with each other. The infrared light from the emitter is detected by the receiver and evaluated.

Function

Static detection:

The thru-beam sensor detects persons and objects independently of movement and surface structure for as long as the object breaks the detection beam.

		Electronic output
Light detection /25	Person in the beam	Inactive
	No person in the beam	Active
Dark detection /59	Person in the beam	Active
	No person in the beam	Inactive

Optics:

The relatively wide opening angles enable the light beam switches to be installed quickly, without alignment problems. Even if there is a light distortion of the installation profiles the function is retained.

Testing:

Testing is used to check the function of the light beam switch.

With supply voltage $+U_B < 5 V$ the emitter device is switched off. This simulates a light beam interruption. By means of this, the function of the light barrier can be tested easily without using a separate test input.

Installation:

Thanks to its small dimensions, the light beam can be fitted in a U-profile or behind a face panel. The hole diameter for both the emitter and the receiver is 8 mm.

Even fixing by means of the adhesive tape contained in the delivery package can be considered.

Installation of twin-beam arrangement:

Release date: 2019-12-18 11:18 Date of issue: 2019-12-18 129312_eng.xml

A twin-beam version requires 2 emitters and receivers. Care should be taken that the beam separation is not less than 20 cm. The transmitters and receivers must be arranged in the form of a cross.

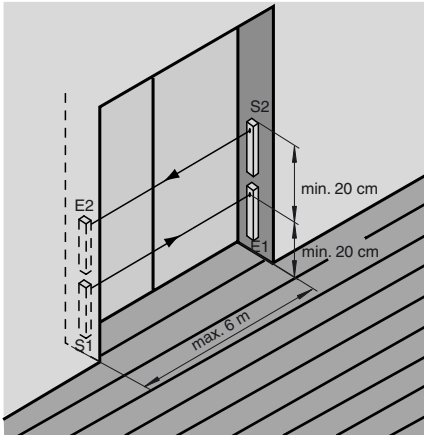



SCATTERGOOD & JOHNSON LTD

ELECTRICAL ENGINEERING & FLUID CONTROL DISTRIBUTORS

Est.1899

At Scattergood & Johnson Ltd, we pride ourselves on being a technical distributor to specialist industries.

Working with a range of quality product suppliers across a number of specialist markets, we are not your average 'box shifter' - we are your technical and supply chain partner.

We fully support every product we sell - for free! Our internal team and external sales engineers can answer any product or application question, no matter the complexity.

Backing up this technical ability is a range of 50,000+ products available from stock for nationwide next day delivery (same day if required!), or you can collect what you need from any of our trade counters around the UK.

Select your specialist interest below to learn more about how we can help.



Online, In Branch and On the Road - Scattergood & Johnson Ltd, there when you need us.

www.scatts.co.uk