



Model Number

MLV41-8-H-350-RT/59/92/136

Background suppression sensor with 4-pin, M12 x 1 connector

Features

- Rugged series in corrosion-resistant metal housing
- Reliable detection of all surfaces, independent of color and structure
- Minimal black-white difference
- Precision background suppression, adjustable
- Extremely high switching frequency
- Clear and functional display concept for the operating modes

Product information

The unique and extremely popular design of the MLV41 series enables it be mounted correctly in confined areas and offers all the functions that are normally only found on larger phototelectric sensors. The MLV41 series comes with a range of functions. For example, highly visible status LEDs on the front and back, resistance to ambient light, crosstalk protection and universally applicable output stages that permit every possible switching logic and polarity to be realized. The enhanced resistance to ambient light ensures reliable operation even where modern energy-saving lamps with electronic ballasts are in use. The same applies where multiple devices are present, i.e. the use of a number of sensors in the same vicinity causes no problems.

Release date: 2019-11-27 14:11 Date of issue: 2019-11-27 183439_eng.xml

Dimensions

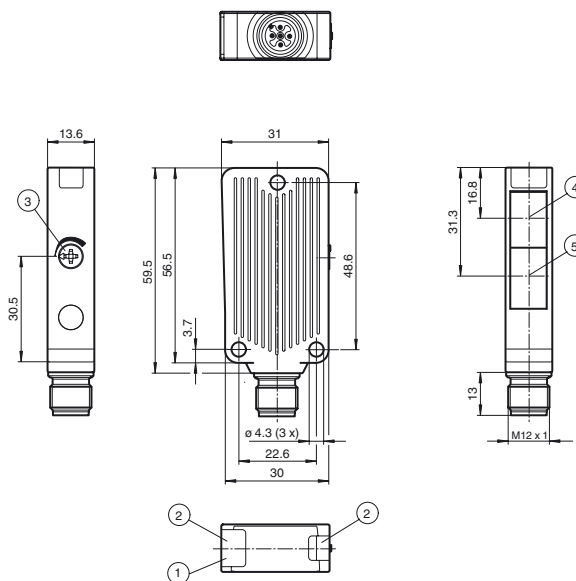

Electrical connection

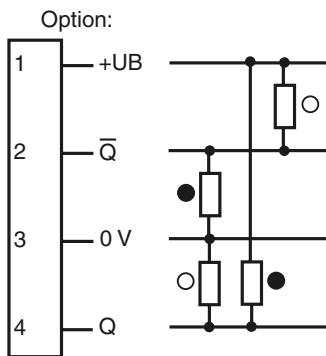

- = Light on
- = Dark on

Pinout

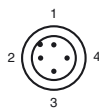

Wire colors in accordance with EN 60947-5-2

- 1 BN (brown)
- 2 WH (white)
- 3 BU (blue)
- 4 BK (black)

Indicators/operating means

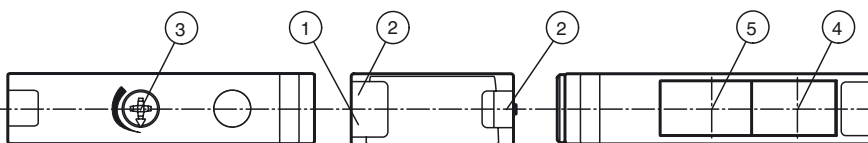

1	Operating display green	3	Sensing range adjuster	5	Optical axis receiver
2	Function display yellow	4	Optical axis transmitter		

Technical data**General specifications**

Detection range	50 ... 350 mm , adjustable
Detection range min.	10 ... 50 mm
Detection range max.	30 ... 350 mm
Adjustment range	50 ... 350 mm
Background suppression	+ 10 % of the upper limit of the detection range
Light source	LED
Light type	modulated visible red light , 660 nm
Black/White difference (6 %/90 %)	< 15 % at 350 mm
Diameter of the light spot	approx. 8 mm at 350 mm sensor range
Angle of divergence	1.5 °
Ambient light limit	40000 Lux

Functional safety related parameters

MTTF _d	1260 a
Mission Time (T _M)	20 a
Diagnostic Coverage (DC)	0 %

Indicators/operating means

Operation indicator	LED green, statically lit Power on , Undervoltage indicator: Green LED, pulsing (approx. 0.8 Hz) , short-circuit : LED green flashing (approx. 4 Hz)
Function indicator	2 LEDs yellow ON: object inside the scanning range OFF: object outside the scanning range
Control elements	Sensing range adjuster

Electrical specifications

Operating voltage	U _B	10 ... 30 V DC
Ripple		max. 10 %
No-load supply current	I ₀	max. 25 mA

Output

Signal output	2 push-pull (4 in 1) outputs, complementary, short-circuit proof, reverse polarity protected	
Switching voltage	max. 30 V DC	
Switching current	max. 100 mA	
Voltage drop	U _d	≤ 2.5 V DC
Switching frequency	f	1000 Hz
Response time		0.5 ms

Conformity

Product standard	EN 60947-5-2
------------------	--------------

Ambient conditions

Ambient temperature	-40 ... 60 °C (-40 ... 140 °F)
Storage temperature	-40 ... 75 °C (-40 ... 167 °F)

Mechanical specifications

Housing width	31 mm
Housing height	56.5 mm
Housing depth	13.6 mm
Degree of protection	IP67
Connection	4-pin, M12 x 1 connector
Material	
Housing	Aluminum , Delta-Seal coated
Optical face	glass pane
Connector	metal
Mass	50 g

Approvals and certificates

Protection class	II, rated voltage ≤ 50 V AC with pollution degree 1-2 according to IEC 60664-1 , functional insulation acc. to DIN EN 50178
UL approval	cULus Listed 57M3 (Only in association with UL Class 2 power supply; Type 1 enclosure)
CCC approval	CCC approval / marking not required for products rated ≤36 V

Accessories**OMH-40**

Mounting bracket

OMH-09

Mounting bracket for Sensors series MLV41 for M12 rod mounting

V1-G-2M-PUR

Female cordset, M12, 4-pin, PUR cable

V1-W-2M-PUR

Female cordset, M12, 4-pin, PUR cable

Other suitable accessories can be found at www.pepperl-fuchs.com

Curves/Diagrams

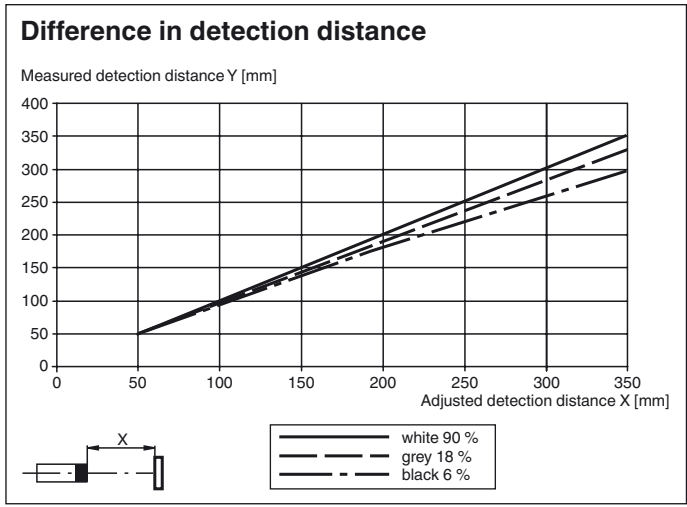
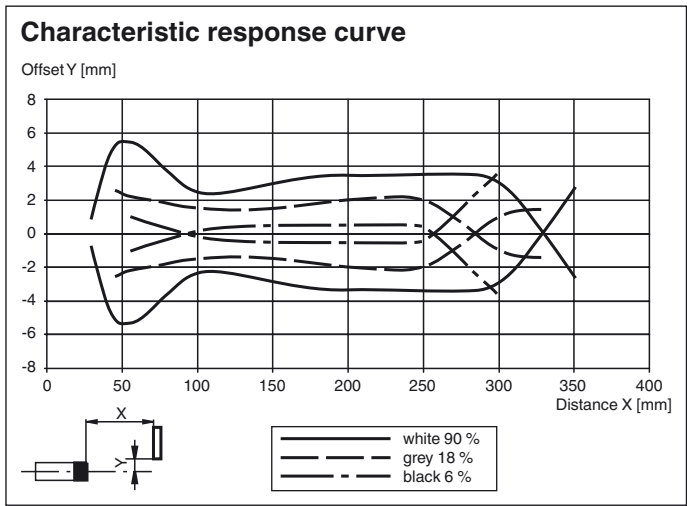

Release date: 2019-11-27 14:11 Date of issue: 2019-11-27 183439_eng.xml

Refer to "General Notes Relating to Pepperl+Fuchs Product Information".



SCATTERGOOD & JOHNSON LTD

ELECTRICAL ENGINEERING & FLUID CONTROL DISTRIBUTORS

Est.1899

At Scattergood & Johnson Ltd, we pride ourselves on being a technical distributor to specialist industries.

Working with a range of quality product suppliers across a number of specialist markets, we are not your average 'box shifter' - we are your technical and supply chain partner.

We fully support every product we sell - for free! Our internal team and external sales engineers can answer any product or application question, no matter the complexity.

Backing up this technical ability is a range of 50,000+ products available from stock for nationwide next day delivery (same day if required!), or you can collect what you need from any of our trade counters around the UK.

Select your specialist interest below to learn more about how we can help.



Online, In Branch and On the Road - Scattergood & Johnson Ltd, there when you need us.

www.scatts.co.uk