

Guide for Selecting Flexible and Robust Glass Fiber Optics

Due to its own design and production, Pepperl+Fuchs is capable of providing you with the ideal fiber optics to suit your application. Choosing the perfect fiber optic takes only four simple steps! Please follow the guide.

Glass fiber optics from Pepperl+Fuchs for the MLV41-LL basic device start with the following designation in the type code:

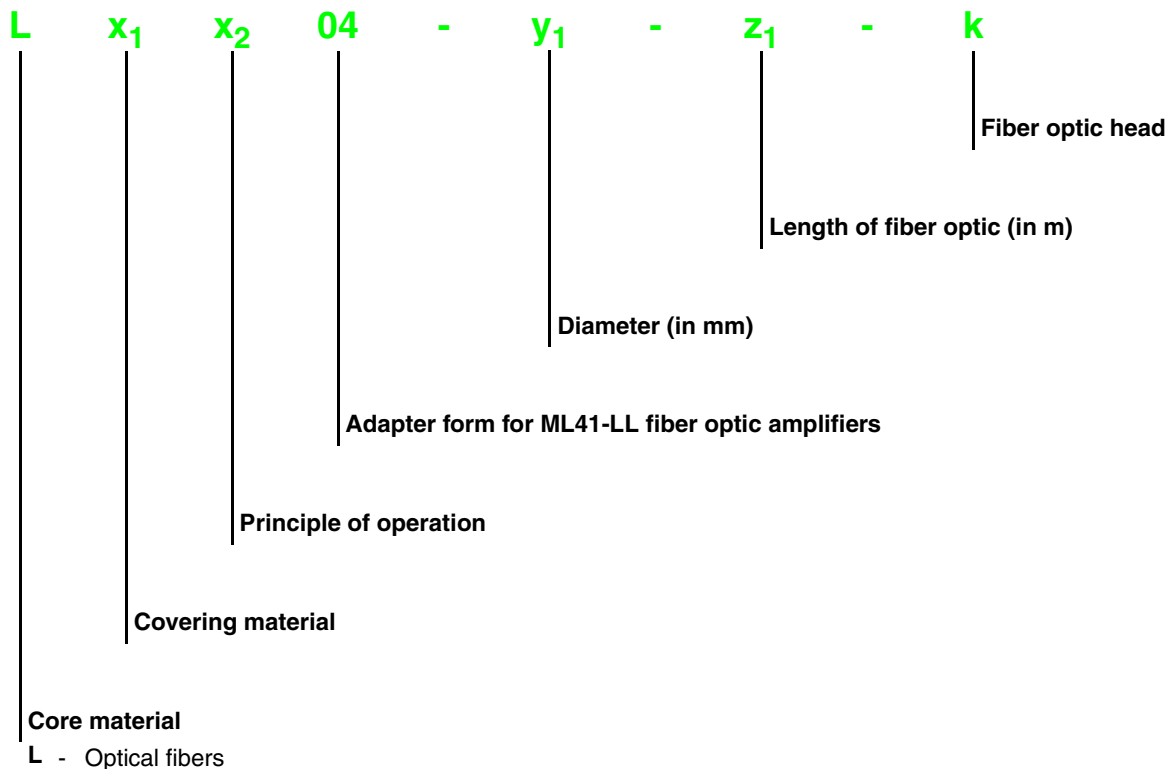

Step 1: Selecting the Principle of Operation **x₂**

Select the principle of operation and enter it for **x₂**.

- E** Thru-beam glass fiber optic for high ranges
- R** Diffuse glass fiber optic for easy mounting

e.g.:

L x₁ R 04 - y₁ - z₁ - k

Step 2: Selecting the Covering Material **x₁**

The given ambient temperatures and the required bending radii determine the preferred covering material. Select your required covering material and enter it for **x₁**.

Covering material	x₁	Max. temperature range	Min. bending radius
PVC	C	-20 °C ... 85 °C	10 ... 15 mm
Silicone	S	-40 °C ... 180 °C	15 ... 20 mm
Metal-silicone	L	-40 °C ... 180 °C	20 mm
Metal	M	-50 °C ... 200 °C	20 mm

e.g.:

LCE 04 - y₁ - z₁ - k

Step 3: Selecting the Required Range **y₁, z₁**

Please select the detection range you require.

The type of light emitter RT (red light) or IR (infrared) in your fiber optic basic device can result in different sensing detection ranges.

There are still differences between thru-beam glass fiber optic and diffuse fiber optic. Choose the principle of operation first. Your required detection range is used as the basis for calculating the values for the diameter **y₁** and length of fiber optic **z₁**.

z₁ Select the required length of fiber optic and enter it into the model number.

y₁ Determine the required fiber cross-section and enter it into the model number.

e.g.:

LCE 04 - 1.1 - 1.0 - k

Thru-Beam Principle of Operation:

Max. detection range when using the MLV41-LL IR fiber optic basic device:

		Max. detection range [mm]*			
		Z ₁ = 0.5 m	Z ₁ = 1 m	Z ₁ = 2 m	Z ₁ = 3 m
y ₁	1.1	100	100	Variable	Variable
	1.6	120	120	Variable	Variable
	1.9	200	Variable	Variable	Variable
	2.3	200	Variable	Variable	Variable

Max. detection range when using the MLV41-LL RT fiber optic basic device:

		Max. detection range [mm]*			
		Z ₁ = 0.5 m	Z ₁ = 1 m	Z ₁ = 2 m	Z ₁ = 3 m
y ₁	1.1	70	70	65	60
	1.6	120	110	105	105
	1.9	variable	variable	variable	variable
	2.3	150	150	146	140

Diffusion Principle of Operation:

Max. detection range when using the MLV41-LL IR fiber optic basic device:

		Max. detection range [mm]*			
		Z ₁ = 0.5 m	Z ₁ = 1 m	Z ₁ = 2 m	Z ₁ = 3 m
y ₁	0.8	variable	variable	variable	variable
	1.1	42	30	22	15
	1.6	90	85	79	75
	1.9	variable	variable	variable	variable
	2.3	160	150	142	130

Max. detection range when using the MLV41-LL RT fiber optic basic device:

		Max. detection range [mm]*			
		Z ₁ = 0.5 m	Z ₁ = 1 m	Z ₁ = 2 m	Z ₁ = 3 m
y ₁	0.8	variable	variable	variable	variable
	1.1	24	20	16	10
	1.6	45	35	30	26
	1.9	variable	variable	variable	variable
	2.3	75	67	62	53

* Detection range measured on white



Note!

A diffuse mode fiber optic cable has a transmitter and receiver each fiber bundle.
 At a fiber bundle cross-section of 2.3 mm resulting in an total fiber bundle cross-section of 3.2 mm.
 At a fiber bundle cross-section of 1,9 mm resulting in an total fiber bundle cross-section of 2,7 mm.
 At a fiber bundle cross-section of 1,6 mm resulting in an total fiber bundle cross-section of 2,3 mm.

Step 4: Selecting the Fiber Optic Head k



Select the desired design of the fiber optic head k, check the availability of the head with relation to the diameter y₁ and enter it into the model number. e.g.:

LCE 04 - 1.1 - 1.0 - K3

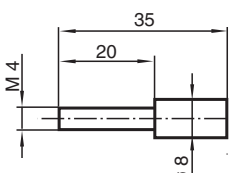
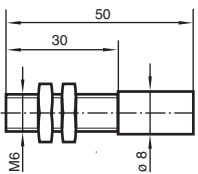
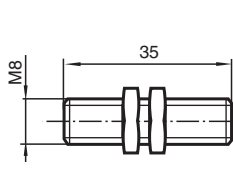
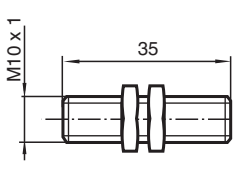
Standard heads with thread:

				
	M4 thread	M6 thread	M8 thread	M10 thread
K	K3	G	K5	K4
y₁	1.1	1.1	1.1	1.1
	1.6	1.9	1.9	1.9
	1.9 (thru-beam only)	2.3	2.3	2.3

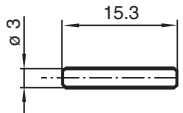
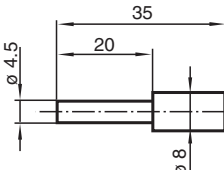
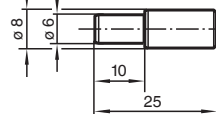
Standard heads, cylindrical:

				
	Diameter 3 mm	Diameter 4.5 mm	Diameter 6/8 mm	Diameter 6 mm
K	15C3	K1	Z1	K7
y1	1.1	1.1	1.1	1.1
	1.3 (thru-beam only)	1.6	1.6	1.6
	-	-	1.9	1.9
	-	2.3	2.3	2.3

* Available with silicone covering only

Standard heads with smooth right angle / thread:

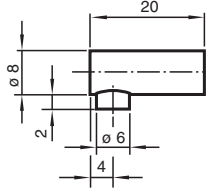
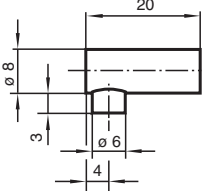
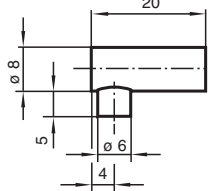
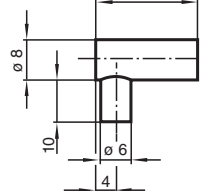
				
	Bar 2 mm	Bar 3 mm	Bar 5 mm	Bar 10/6 mm
K	WC2	WC3	WC5	WC10
y1	1.1	1.1	1.1	1.1
	1.6	1.6	1.6	1.6*
	2.3	2.3	2.3	2.3

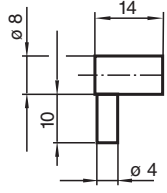
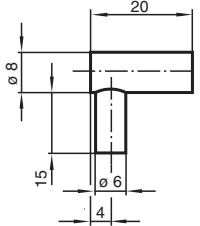
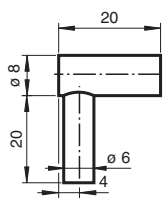
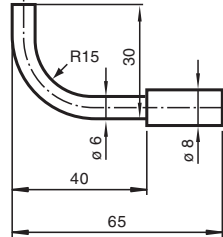
				
	Bar 10/4 mm	Bar 15 mm	Bar 20 mm	Radius 15 mm
K	K9	WC15	WC20	WR
y1	1.1	1.1	1.1	1.1
	1.6	1.6	1.6	1.6
	-	1.9	1.9	1.9
	2.3 (thru-beam only)	2.3	2.3	2.3

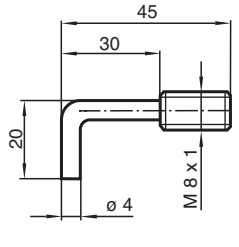
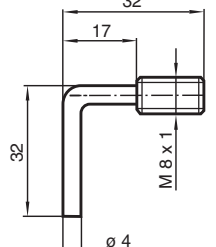
		
	Bar 20 mm / M8 x 1	Bar 32 mm / M8 x 1
K	K11	K12
y1	1.1	1.1
	1.6	1.6
	2.3 (thru-beam only)	2.3 (thru-beam only)

Date of issue: 13.10.2011 DOCT-1480

Standard heads with flexible tip:

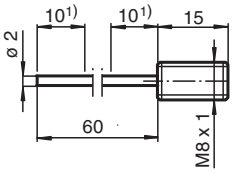
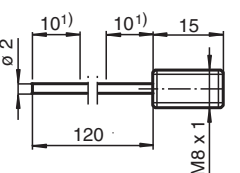
		
	60 mm tip	120 mm tip
K	K13	K14
y₁	0.8	0.8
	1.1 (thru-beam only)	1.1 (thru-beam only)

Standard heads with lateral light exit:

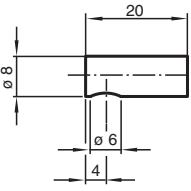
	
K	WC0
y₁	1.1
	1.6
	1.9
	2.3

This results, e.g. in the following complete model number:
e.g.:

LCE 04 - 1.1 - 1.0 - K3

If you fail to find what you are looking for in our comprehensive standard product range, you can ask one of our experts!

Additional accessories such as focussing lenses for increasing the detection range and sensing ranges are available on the Internet.

Order form for your fiber optics selection:

L x₁ x₂ 04 - y₁ - z₁ - k

Core material	Covering material x₁	Principle of operation x₂	Adapter	Diameter y₁	Length of fiber optic z₁	Fiber optic head k	Quantity
I			04				
I			04				
I			04				
I			04				
I			04				
I			04				
I			04				



SCATTERGOOD & JOHNSON LTD

ELECTRICAL ENGINEERING & FLUID CONTROL DISTRIBUTORS

Est.1899

At Scattergood & Johnson Ltd, we pride ourselves on being a technical distributor to specialist industries.

Working with a range of quality product suppliers across a number of specialist markets, we are not your average 'box shifter' - we are your technical and supply chain partner.

We fully support every product we sell - for free! Our internal team and external sales engineers can answer any product or application question, no matter the complexity.

Backing up this technical ability is a range of 50,000+ products available from stock for nationwide next day delivery (same day if required!), or you can collect what you need from any of our trade counters around the UK.

Select your specialist interest below to learn more about how we can help.



Online, In Branch and On the Road - Scattergood & Johnson Ltd, there when you need us.

www.scatts.co.uk