

Features

- 2-channel signal conditioner
- 24 V DC supply
- PNP/push-pull, dry contacts or NAMUR inputs
- Selectable frequency trip values
- 2 relay contact outputs
- Start-up override
- Selectable mode of operation
- Without line fault detection
- Up to SIL 2 acc. to IEC 61508

Function

This signal conditioner provides the galvanic isolation between field circuits and control circuits.

This device is a standstill monitor that accepts input frequency pulses and triggers an output when the frequency drops below a preselected limit value.

Two start-up override values are available. This unit can also be used to determine rotation direction.

During an error condition or a power loss, the relay reverts to its de-energized state and the LEDs indicate the fault according to NAMUR NE 44. A line fault is not indicated.

The device has LED status indicators for direction of rotation detection, limit detection, supply, and hardware faults.

The device is easily configured by the use of DIP switches.

For additional information, refer to www.pepperl-fuchs.com.

Assembly

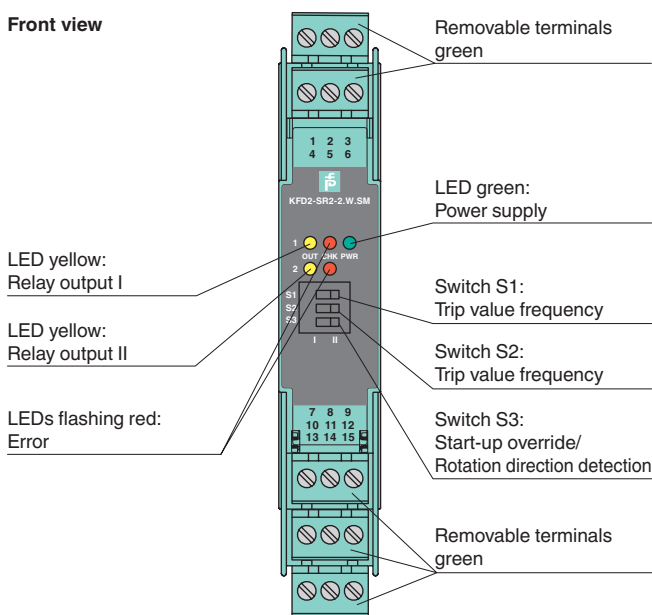

CE

SIL 2

Connection

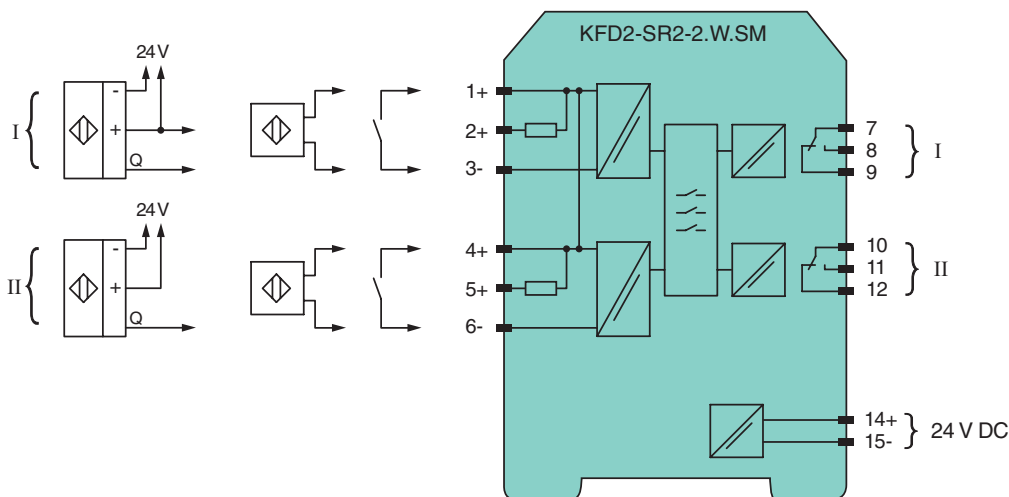

Release date 2020-01-15 14:22 Date of issue 2020-01-15 132965_eng.xml

Refer to "General Notes Relating to Pepperl+Fuchs Product Information".

General specifications	
Signal type	Digital Input
Programming	via DIP switch and programmable
Functional safety related parameters	
Safety Integrity Level (SIL)	SIL 2
Supply	
Connection	terminals 14+, 15-
Rated voltage U_r	20 ... 30 V DC
Power consumption	≤ 1.5 W
Input	
Connection side	field side
Connection	Input I: terminals 1+, 2+, 3- ; Input II: terminals 4+, 5+, 6-
Rated values	acc. to EN 60947-5-6 (NAMUR)
Open circuit voltage/short-circuit current	approx. 8 V DC / approx. 8 mA
Switching point/switching hysteresis	1.2 ... 2.1 mA / approx. 0.2 mA
Line fault detection	not available
Control input	sensor power supply approx. 8.2 V, impedance 1.2 kΩ
Pulse duration	> 200 μs for standstill monitoring, > 250 μs for rotation direction detection
Output	
Connection side	control side
Connection	output I: terminals 7, 8, 9 ; output II: terminals 10, 11, 12
Contact loading	253 V AC/2 A/cos φ > 0.7; 126.5 V AC/4 A/cos φ > 0.7; 40 V DC/2 A resistive load
Minimum switch current	2 mA / 24 V DC
Energized/De-energized delay	approx. 20 ms / approx. 20 ms
Mechanical life	10 ⁷ switching cycles
Trip value f_{max}	for standstill monitoring: 0.1 Hz; 0.5 Hz; 2 Hz; 10 Hz adjustable via DIP switch (S1 and S2)
Transfer characteristics	
Accuracy	5 % (S3 = I), 30 % (S3 = II)
Start-up override	5 seconds or 20 seconds, programmable
Frequency range	≤ 2 kHz
Rotation direction detection	90° phase difference between pulse input signal 1 and 2, overlapping ≥ 125 μs
Galvanic isolation	
Input/Output	reinforced insulation according to IEC/EN 61010-1, rated insulation voltage 300 V _{eff}
Input/power supply	reinforced insulation according to IEC/EN 61010-1, rated insulation voltage 300 V _{eff}
Output/power supply	reinforced insulation according to IEC/EN 61010-1, rated insulation voltage 300 V _{eff}
Output/Output	reinforced insulation according to IEC/EN 61010-1, rated insulation voltage 300 V _{eff}
Indicators/settings	
Display elements	LEDs
Control elements	DIP-switch
Configuration	via DIP switches
Labeling	space for labeling at the front
Directive conformity	
Electromagnetic compatibility	
Directive 2014/30/EU	EN 61326-1:2013 (industrial locations)
Low voltage	
Directive 2014/35/EU	EN 61010-1:2010
Conformity	
Electromagnetic compatibility	NE 21:2006
Degree of protection	IEC 60529:2001
Input	EN 60947-5-6:2000
Ambient conditions	
Ambient temperature	-20 ... 60 °C (-4 ... 140 °F)
Mechanical specifications	
Degree of protection	IP20
Connection	screw terminals
Mass	approx. 150 g
Dimensions	20 x 119 x 115 mm (0.8 x 4.7 x 4.5 inch) , housing type B2
Mounting	on 35 mm DIN mounting rail acc. to EN 60715:2001
General information	

Release date 2020-01-15 14:22 Date of issue 2020-01-15 132965_eng.xml

Refer to "General Notes Relating to Pepperl+Fuchs Product Information".

Pepperl+Fuchs Group
www.pepperl-fuchs.com

USA: +1 330 486 0002
pa-info@us.pepperl-fuchs.com

Germany: +49 621 776 2222
pa-info@de.pepperl-fuchs.com

Singapore: +65 6779 9091
pa-info@sg.pepperl-fuchs.com

Supplementary information	Observe the certificates, declarations of conformity, instruction manuals, and manuals where applicable. For information see www.pepperl-fuchs.com .
Accessories	
Optional accessories	<ul style="list-style-type: none"> - power feed module KFD2-EB2(.R4A.B)(.SP) - universal power rail UPR-03(-M)(-S) - profile rail K-DUCT-GY(-UPR-03)

Operating principle

The function of standstill monitor with start-up override (S3 = I) or standstill monitor with rotation direction monitoring (S3 = II) can be selected by means of DIP switches.

S3:	I	II
Function:	Standstill monitor with start-up override	Standstill monitor with rotation direction monitoring
Input I:	Pulse input 1: NAMUR contacts (bounce-free)	Pulse input 1: NAMUR contacts (bounce-free)
Input II:	Start-up override: contact terminal 4 + 6: 20 seconds contact terminal 5 + 6: 5 seconds	Pulse input 2: NAMUR contacts (bounce-free)
Output I:	MIN/passive	MIN/passive
Output II:	MIN/active	Direction of rotation/error

Standstill monitor with start-up override (S3 = I)

If the frequency falls below the trip value set with the DIP switches S1 and S2, the standstill monitor with start-up override switches the output I to passive and the output II to active. Input I is used to monitor the frequency of rising current edges. Signal transmitters can be sensors in accordance with EN 60947-5-6 (NAMUR) or contacts. A start-up override can be initiated via input II. The duration of the start-up override can be selected between 5 and 20 seconds by means of a bridge (starting trigger) or an external trigger signal. During the start-up override time the outputs assume the "no standstill" state.

Trip value	Hysteresis	Switch S2	Switch S1
0.1 Hz	0.02 Hz	I	I
0.5 Hz	0.1 Hz	I	II
2 Hz	0.4 Hz	II	I
10 Hz	2 Hz	II	II

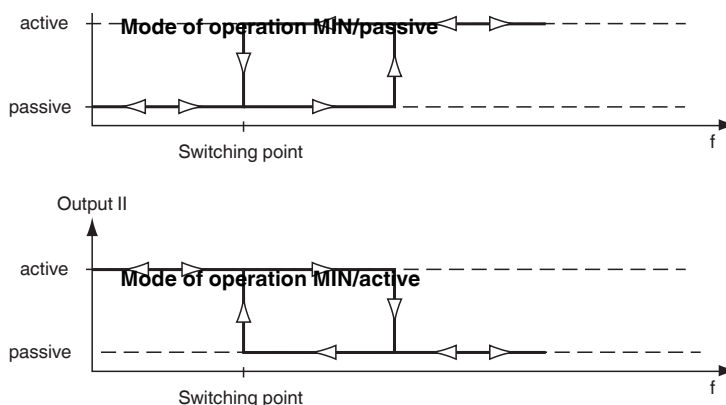

Release date 2020-01-15 14:22 Date of issue 2020-01-15 132965_eng.xml

Refer to "General Notes Relating to Pepperl+Fuchs Product Information".

Standstill monitor with rotation direction monitoring (S3 = II)

The device also offers stand still monitoring with direction of rotation monitoring as an alternative to stand still monitoring with start-up override. The trip values are identical to the standstill monitor with start-up override. At input II a signal that is offset by 90° to input I has to be applied; in this context minimum signal overlapping should be ensured. Signal transmitters at input I and input II can be sensors in accordance with DIN EN 60947-5-6 (NAMUR) or contacts. Output I is used for standstill signalling and switches to a de-energized state (passive) in the event of a standstill. Output II is switched to active when the direction of rotation is clockwise. If a reverse rotation is detected or if a signal overlap is missing, output II switches to a de-energized state (passive). In this case it can be concluded, that the sensor is misadjusted or defective. If the sensor at input I is misadjusted or defective, input II is used for standstill monitoring.

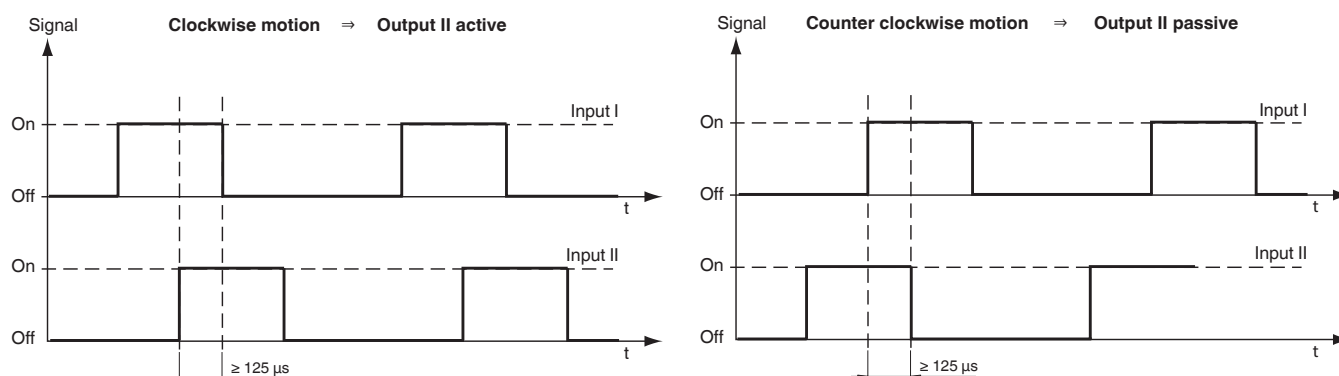
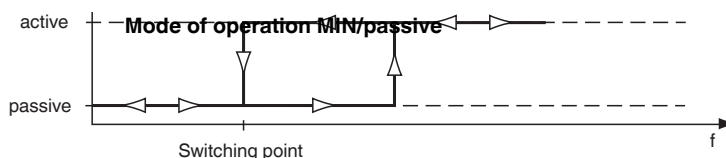

Behaviour during malfunction: continuous monitoring of the device for errors in internal memory

If an error occurs, both relays go into the secure state and the red LEDs indicate the error.

Advice on use in SIL2 applications (Functional safety)

Care should be taken to ensure that the relays are de-energized (passive) in the critical condition of the application. Then, in the event of a power failure (de-energized, passive relay) the safety-critical state (energized) relay cannot be achieved.

Example 1:

The protective guard for a rotating shaft must remain locked in position until the shaft has stopped rotating. The safety-critical condition is the rotation of the shaft (risk of injury). For this reason, the locking of the protective guard should be achieved by means of a de-energized (passive) relay. The relay shall be energized (active) only when the shaft has stopped (safe condition). This device function is only achieved with "Standstill monitoring with start-up override" (S3 = I) and control of the protective guard with relay 2.

Example 2:

The cooling of a critical process by means of fans/coolant pumps has to be monitored. The safety-critical condition is the standstill of the fans/pumps (overheating). For this reason an alarm must be triggered when a relay has de-energized (passive). As long as the fans or the pumps are running (safety condition) the relay is energized (active). This device function can be achieved with "Standstill monitoring with start-up override" (S3 = I) and "Standstill monitoring with direction of rotation signalling" (S3 = II) with relay 1.

Release date 2020-01-15 14:22 Date of issue 2020-01-15 132965_eng.xml

Maximum switching power of output contacts

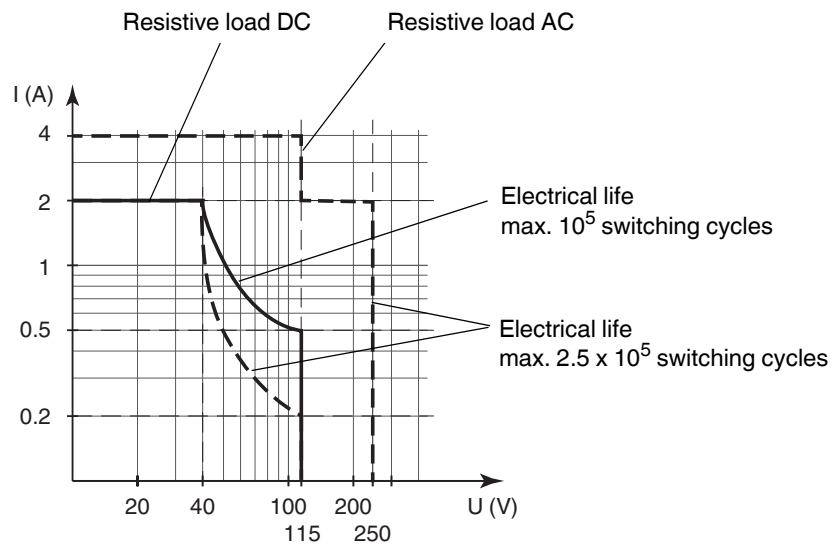

The maximum number of switching cycles is depending on the electrical load and may be higher when reduced currents and voltages are applied.



SCATTERGOOD & JOHNSON LTD

ELECTRICAL ENGINEERING & FLUID CONTROL DISTRIBUTORS

Est.1899

At Scattergood & Johnson Ltd, we pride ourselves on being a technical distributor to specialist industries.

Working with a range of quality product suppliers across a number of specialist markets, we are not your average 'box shifter' - we are your technical and supply chain partner.

We fully support every product we sell - for free! Our internal team and external sales engineers can answer any product or application question, no matter the complexity.

Backing up this technical ability is a range of 50,000+ products available from stock for nationwide next day delivery (same day if required!), or you can collect what you need from any of our trade counters around the UK.

Select your specialist interest below to learn more about how we can help.



Online, In Branch and On the Road - Scattergood & Johnson Ltd, there when you need us.

www.scatts.co.uk