

MANUAL

# Frequency Converter with Trip Values KF\*\*-UFC-(Ex)1.D



With regard to the supply of products, the current issue of the following document is applicable:  
The General Terms of Delivery for Products and Services of the Electrical Industry,  
published by the Central Association of the Electrical Industry  
(Zentralverband Elektrotechnik und Elektroindustrie (ZVEI) e.V.) in its most recent  
version as well as the supplementary clause: "Expanded reservation of proprietorship"

1	<b>Symbols Used</b>	3
2	<b>Overview</b>	3
2.1	<b>Range of Application</b>	3
2.2	<b>Model variants</b>	4
3	<b>Safety Notes</b>	5
4	<b>Explosion Protection</b>	6
5	<b>Installation and Connection</b>	6
5.1	<b>Installation</b>	6
5.2	<b>Connection</b>	7
5.3	<b>Front Side of the Device</b>	10
6	<b>Display Modes and Error Messages</b>	10
7	<b>Editing Device Data</b>	11
7.1	<b>Parameterization Mode Control Panel</b>	11
7.1.1	Invocation	11
7.1.2	Password	12
7.1.3	Navigation Method	13
7.1.4	Lowest Menu Level: Choose Values, Enter Numbers	14
7.2	<b>Units</b>	15
7.3	<b>Input</b>	17
7.3.1	Pulses/Unit	18
7.3.2	Start-up Override	19
7.4	<b>Output</b>	20

<b>7.5</b>	<b>Switching Outputs</b> .....	<b>20</b>
7.5.1	Limit Switch .....	21
7.5.2	Operating Behaviour .....	22
7.5.3	Switching Point and Hysteresis .....	23
7.5.4	Restart Inhibit .....	23
7.5.5	Serial Switching .....	24
7.5.6	Pulse Divider .....	24
7.5.7	Error Switch .....	25
<b>7.6</b>	<b>Current Output</b> .....	<b>26</b>
7.6.1	Current Path Characteristic .....	27
7.6.2	Fault Current .....	28
7.6.3	Start Value and Final Value .....	29
<b>7.7</b>	<b>Service</b> .....	<b>29</b>

## 1 Symbols Used



Warning

*This symbol warns of possible danger.*

*Failure to heed this warning may result in personal injury or death, or property damage, including destruction.*



Attention

*This symbol warns the user of a possible fault.*

*Failure to heed this warning can lead to total failure of the device and any other connected equipment.*



Note

*This symbol draws attention to important information.*

## 2 Overview

### 2.1 Range of Application

The K-System devices from Pepperl+Fuchs are used for transmitting signals between field devices and a process control system/control system.

The devices marked with "Ex" in the type designation are suitable for the connection of field devices used in potentially explosive atmospheres. Safe field circuits for these devices are intrinsically safe and are galvanically isolated from non-intrinsically safe circuits. The devices thus establish an electromagnetic separation between the potentially explosive atmospheres and the safe areas in a system.

Devices without Ex-identification can be used to transmit signals between field devices and the process control system/control unit.



Typical applications for the K-System KF\*\*-UFC-(Ex)1(.D) universal frequency converter are flow and RPM measurements.

The device accomplishes this by converting an input frequency into a frequency-proportional current which can, for example, then be redirected to a display device or the analogue input of the process control system/control system.

Moreover, the device can be used as a signal divider and as a rotational speed controller (limit-value display for MAX alarm and for MIN alarm).

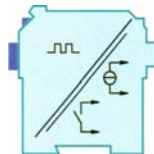

More information (for example, certificates and data sheets for the devices and the operating manual for the K-System) can be found on our webpage [www.pepperl-fuchs.com](http://www.pepperl-fuchs.com) (enter "UFC" in the product search).

## 2.2 Model variants

The following versions of the universal frequency converter are available:

KF\*\*-UFC-\*\*1\*\*

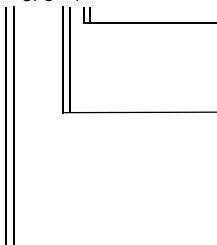

.D = with control panel

without a dot and identifying letter = no control panel

Ex = for connecting field devices outside the area subject to the danger of explosion

without identifying letter = for connecting field devices in the safe area

D2 = with power supply for 24 V DC (green cover on output side); for power supply via Power Rail with error message cache, please consult the Pepperl+Fuchs catalogue "Interface DIN-Rail Housing", or the CD-ROM catalogue.

U8 = with universal voltage power supply, which can use an input voltage from 20 V DC up to 90 V DC, and 48 V AC up to 253 V AC, with no need for switching or for matching polarity (grey cover on output side)

### 3 Safety Notes



Warning

*The devices must only be operated by trained personnel in accordance with this handbook.*



Warning

*The protection of operating personnel and of the system is only ensured if the devices are used in accordance with their intended purpose. Any other type of operation than that described in this manual places the safety and functionality of the devices and systems connected to them in question.*



Warning

*The devices may only be installed, connected, and adjusted by electrical professionals **outside the hazardous area.***



Warning

*If faults cannot be eliminated, the devices must be taken out of operation and protected from being placed in service again inadvertently. Devices must only be repaired directly by the manufacturer Pepperl+Fuchs. Tampering with or making changes to the devices is dangerous and therefore not permitted. They render the warranty void.*



Note

*The responsibility for the adherence to local safety standards lies with the operator.*

## 4 Explosion Protection

For primary explosion protection, that is, for measures to be taken to prevent or hinder the development of a dangerous explosive atmosphere, observe the directive 2014/34/EU and the corresponding national guidelines.

For secondary explosion protection, that is, for measures to hinder the ignition of a surrounding explosive atmosphere by electrical devices, Pepperl+Fuchs will make the explosion protection compendium available to you.

Note in particular EN 60079-0, EN 60079-11, EN 60079-15 and EN 60079-26, or the corresponding national guidelines.

Pepperl+Fuchs also offers a seminar on the topic of explosion protection.

## 5 Installation and Connection

### 5.1 Installation



Attention

*The Frequency Converter with Trip Values KF\*\*-UFC-(Ex)1.D is constructed in protection degree IP20 and must therefore be protected from undesirable ambient conditions (water, small foreign objects).*

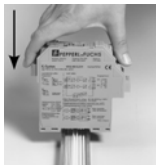

The devices of the K-system from Pepperl+Fuchs and thus also the Frequency Converter with Trip Values KF\*\*-UFC-(Ex)1.D can be mounted on a 35 mm standard rail corresponding to DIN EN 60175. The devices must be snapped onto the rail **vertically**, and never slanted or tipped to the side.

Additional possibilities for mounting, e. g. using the Power Rail, can be found in the data sheets and in the K-System operating manual on our webpage [www.pepperl-fuchs.com](http://www.pepperl-fuchs.com) (enter "UFC" in the product search).

Dimensions of the device  
in mm (\*)

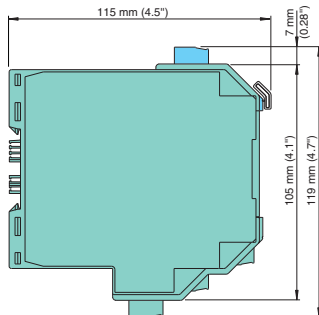

## 5.2 Connection

The removable terminals of the KF-series considerably simplify the connection and the switch cabinet assembly. They make it possible to replace devices quickly and without error if a customer service becomes necessary.

Terminals are equipped with screws, are self-opening, have a large connection area for a wire cross-section up to 2.5 mm<sup>2</sup> and coded plugs, making it impossible to mix them up.



The intrinsically safe field circuit is connected to the **blue** terminals 1 and 3 of the device. These may be guided into the potentially explosive areas with connector cables in accordance with DIN EN 60079-14. Terminal 2 of the device is always left unconnected.

The non-intrinsically safe field circuit is connected to the **green** terminals 1 through 3 of the device.

You can connect:

- a sensor corresponding to DIN EN 60947-5-6 (NAMUR)
- a mechanical contact
- **only** KF\*\*-UFC-1(.D): a three-lead sensor (PNP, NPN, push-pull output stage)

For sensors that do not have the appropriate internal resistors, you can add the following externally (as close as possible to the sensor):

- a parallel resistor for open-circuit monitoring (**not** possible for NPN sensors or push-pull output stages)
- a series resistor for short circuit monitoring

In reference to these monitoring options, please see also section 7.2.

Terminals 4 to 6 do not exist.

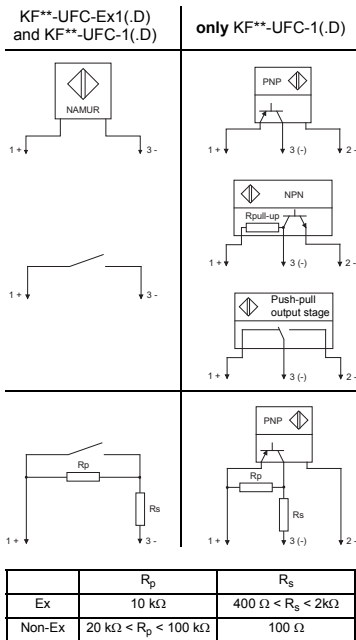

NPN: 2.2 k $\Omega$  <  $R_{pull-up}$  < 3.3 k $\Omega$ ;  
can also be connected externally.

The functions of the other green terminals are as follows:

- Terminals 7/8: current output (9 unused)
- Terminals 10 to 12: relay 1
- Terminals 13/14: start-up override or pulse suppression input (15 unused)
- Terminals 16 to 18: relay 2
- Terminals 19/20: transistor output (21 unused)
- Terminals 23/24: power supply (22 unused)

For power supply using the Power Rail, please consult the "Interface DIN-Rail Housing" catalogue from Pepperl+Fuchs, or the CD-ROM catalogue.

On the exact terminal assignments, please see also the data sheet.

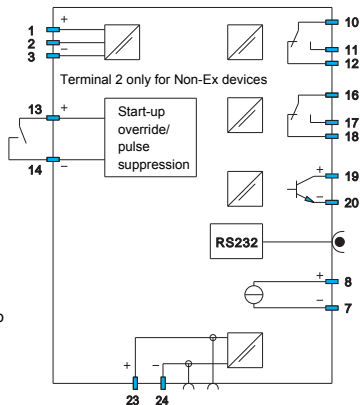

### 5.3 Front Side of the Device

On the front side of the device you will find:

- LED IN CHK 1 (yellow/red) for display
  - of input pulses (flashes yellow cyclically)
  - of an input malfunction (flashes red)
  - of a device malfunction (continuously red)
- LED PWR (green) for displaying the supply voltage
- LED OUT 1 (yellow) to indicate relay 1 active
- LED OUT 2 (yellow) to indicate relay 2 active
- LED OUT 3 (yellow) to indicate transistor active
- a display to show measurement values and malfunctions and for parameterization mode
- four keys for parameterization on the device
  - ▲ (Up)                      ▼ (Down)                      ESC (Escape)                      OK
- Interface for connecting a computer for parameterization and diagnostics of the device with the **FACTware™** operating software, using the K-ADP-USB adapter

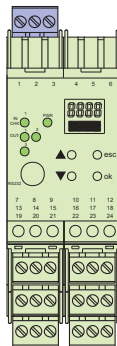

### 6 Display Modes and Error Messages

The current measurement value is shown on the display in normal operating mode. On selecting the unit, see chapter 7.2.

If restart inhibit (see chapter 7.5.4) has been triggered, but the device is still working in normal mode, a message to that effect appears in the second line of the display.

If a malfunction occurs, one of the following messages is displayed (during appropriate parameterization) until the malfunction is eliminated:

- *Err Device error*
- *Err LB* for an lead breakage
- *Err SC* for a short circuit

On selecting error messages see chapter 7.3.

The switch outputs always revert to a no-current state when there is a malfunction.

## 7 Editing Device Data



Warning

*A change in device data will change the operation of the device!  
Before entering new data into the device, you should therefore be certain that  
no danger to the installation will result.*



Note

*In this manual, the parameterization of the device via the control panel is  
described. Parameterization by means of a PC is more convenient.  
The necessary K-ADP-USB can be ordered from Pepperl+Fuchs. The  
**PACTware™** operating software and the manual are available on our Internet page  
[www.pepperl-fuchs.com](http://www.pepperl-fuchs.com) under Software > PACTware.*

*Some specialized functions can only be selected using **PACTware™**,  
for instance, pulse suppression as an alternative to the start-up override.*

### 7.1 Parameterization Mode Control Panel

#### 7.1.1 Invocation

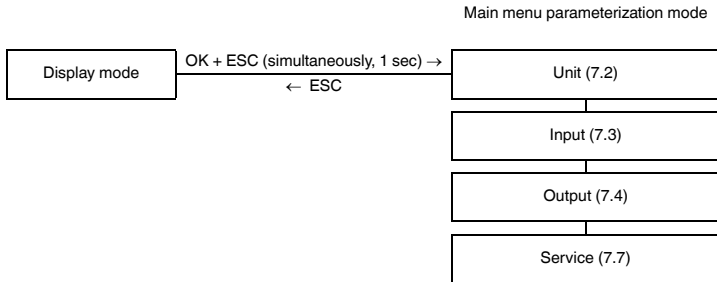

You can return to display mode from any point in the menu in parameterization mode by pressing the ESC key (possibly multiple times). If you do not press any key for 10 minutes in parameterization mode, the device automatically switches back into display mode.

### 7.1.2 Password

You can protect the current configuration from unauthorized changes by using a password (see chapter 7.7; inactive when the device is delivered).

If password protection is active, the various settings in parameterization mode are visible before entry of the password, but may not be changed. The first time an attempt is made to change a setting, the device automatically displays a window for entering the password.

You must enter the password **once each time** after switching from display mode to parameterization mode.

The password cannot be changed and is **1234**.

How to enter the password:

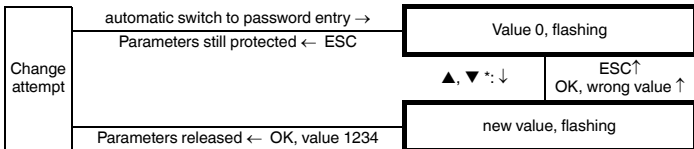

\*If the ▲ or ▼ keys are pressed, the value changes stepwise; if the ▲ or ▼ keys are held down for a longer period, the value "rolls" to higher or lower values.

### 7.1.3 Navigation Method

The following illustration shows the navigation method in parameterization mode using the ▲, ▼, OK, and ESC keys:

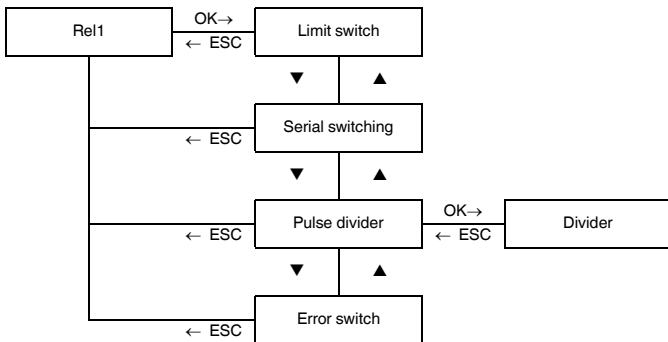

#### 7.1.4 Lowest Menu Level: Choose Values, Enter Numbers

At the lowest level of the menus, you can either choose between particular possible values for individual parameters, or enter a numeric value.

This is done as follows:

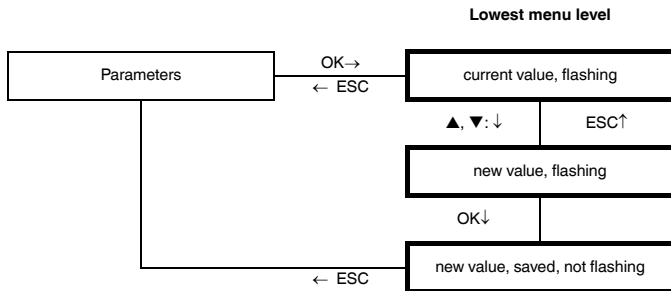

When entering **numeric values**, please note:

- If you press the ▲ or ▼ key, the value changes stepwise.
- If you hold the ▲ or ▼ key for a longer time, the value "rolls" to higher or lower values.
- The sign switches automatically.
- The decimal point is moved automatically.
- The factor of the measurement units will be switched automatically, for example from Hz to kHz.

## 7.2 Units

The following illustration shows the units menu. Menu items on the lowest level are outlined in bold.

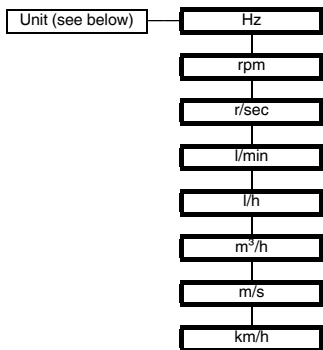

The **Unit** is used for display of measured values and for all corresponding settings in parameter is at ion mode. The device always works internally in Hz (actually in mHz = 0.001 Hz).

If you want the measurement value to be displayed in rpm or r/sec, the number of input pulses per revolution must be specified (see chapter 7.3.1).

Units are then converted as follows:

- $\text{rpm} = \frac{(\text{Hz} \cdot 60)}{\text{Pulses per revolution}}$
- $\text{r/sec} = \frac{\text{Hz}}{\text{Pulses per revolution}}$

If you want the measurement value to be displayed in l/min, l/h or m<sup>3</sup>/h, m/s, km/h the number of input pulses per liter, per m<sup>3</sup>, per m or per km must be specified (see chapter 7.3.1).

The units are then converted as specified:

- $\text{l/min} = \frac{\text{Hz} \cdot 60}{\text{Pulses per liter}}$
- $\text{l/h} = \frac{\text{Hz} \cdot 3600}{\text{Pulses per liter}}$  (Measurement range restricted: 0.001 Hz to 550 Hz)
- $\text{m}^3/\text{h} = \frac{\text{Hz} \cdot 3600}{\text{Pulses per m}^3}$  (Measurement range restricted: 0.001 Hz to 550 Hz)
- $\text{m/s} = \frac{\text{Hz} \cdot 1000}{\text{Pulses per km}}$  (Measurement range restricted: 0.001 Hz to 2 kHz)
- $\text{km/h} = \frac{\text{Hz} \cdot 3600}{\text{Pulses per km}}$  (Measurement range restricted: 0.001 Hz to 550 Hz)

### 7.3 Input

The following illustration shows the menus for the input parameters. Menu items on the lowest level are outlined in bold. Menu items which only appear under certain conditions are marked in grey.

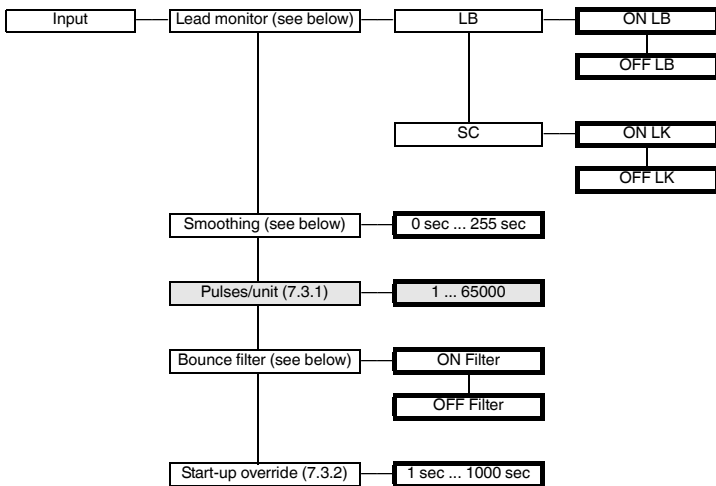

- For **lead fault** monitoring, terminal 3 is watched to see whether no current is flowing (lead break/open circuit) or the input current is too high (short circuit).
- For lead break monitoring, an appropriate parallel resistor must be present in the sensor or externally. For short-circuit monitoring, an appropriate series resistor must be present in the sensor or externally (see chapter 5.1). No lead break monitoring is possible for NPN sensors and push-pull output stages. If you are using a sensor of this type, you should always select OFF for LB.
- In the case of strongly varying measurement values, you can use **smoothing** to influence how quickly an output will react to a change in input:  
0 sec = no smoothing, 255 sec = maximum smoothing.
- A **bounce filter** may be necessary when mechanical contacts are used. You can use the bounce filter of the device if the frequencies to be processed are always lower than 10 Hz.

### 7.3.1 Pulses/Unit

The menu option *Pulses/unit* only appears if you have selected a unit other than Hz for the measurement value display (see chapter 7.2).

Depending on the unit chosen, you must enter the number of pulses per revolution, per liter, per m<sup>3</sup>, or per km. Pulses per km should also be entered for the unit m/s. For conversions, please consult section 7.2.

Examples:

- The speed of a stirring mechanism will be displayed in rpm (or r/sec). The stirring mechanism consists of 8 stirring blades that are detected by the sensor. The number of pulses to enter per unit (revolution) is therefore 8.
- Flow through a water meter will be displayed in l/min (or l/h). The meter returns 20 pulses per liter. This value should be entered. For a display in m<sup>3</sup>/h, 20,000 pulses per unit (m<sup>3</sup>) should be entered.
- The speed of a conveyor belt will be displayed in m/s (or km/h). The sensor detects 8 pulses per revolution on the drive wheel. The drive wheel has a diameter of 0.4 m, thus its circumference is 1.256 m. Therefore, you should enter  
 $8 \cdot 1000 / 1.256 = 6369$  pulses per unit (m).

### 7.3.2 Start-up Override

Activation of start-up override and its effect:

- You can activate start-up override with a signal to terminals 13/14 (at least 100 ms).
- Start-up override prevents switch outputs from signalling a limit violation during the configured override period (start-up phase).
- Start-up override affects only those switch outputs with the MIN switching direction (see chapter 7.5.1). If a switch output has active as its mode of operation, it will remain de-energized during the override period. If its mode of operation is passive, it will be forced to remain energized during the override period (on the mode of operation, see chapter 7.5.1).
- The start-up override is edge triggered: before it can be triggered again, the signal must be turned off on terminals 13/14 for at least 200 ms. If a signal interruption occurs and a new signal arrives during the override period, the timer is restarted.

Pulse suppression:

Using the **PACT<sub>ware</sub>**<sup>TM</sup> software (this is not possible with the control panel), you can alternatively select pulse suppression instead of start-up override.

- If pulse suppression is selected, the device will ignore all incoming pulses, as long as a signal is present on terminals 13/14. It then behaves for all evaluations as though the start value of the measurement range is constantly applied.
- If pulse suppression has been selected, start-up override is deactivated. Restart inhibit is also not possible (see chapter 7.5.4).

If problems should occur with the start-up override, use the **PACT<sub>ware</sub>**<sup>TM</sup> software to check whether pulse suppression may have been selected.

## 7.4 Output

The following illustrations show the menus for the output parameters.

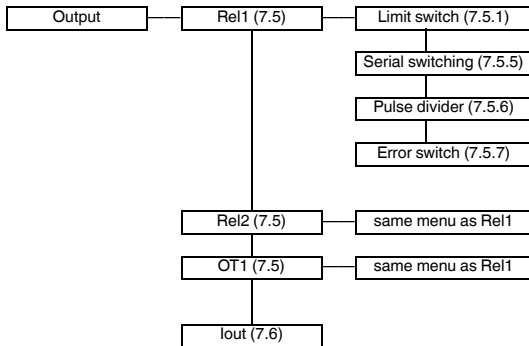

## 7.5 Switching Outputs

From the *Rel1*, *Rel2* and *OT1* menu options, the OK key takes you to a menu in which you can enter parameters for the selected switch output. The three menus are completely identical and will therefore be described only once.

When the function of a switch output is activated (*Limit switch*, *Serial switching*, *Pulse divider* or *Error switch*), this is indicated by *On*. If you want to activate a different function, first select the function with the ▲ and ▼ keys. Then press the OK key twice. After the first OK you can still cancel with ESC.

### 7.5.1 Limit Switch

The following illustration shows the menu levels which are accessible through the *Limit switch* menu option. Menu items on the lowest level are outlined in bold.

If the *Limit switch* function is activated (*On*), the OK key takes you from the *Limit switch* menu option to the *MIN/MAX* menu option. If you activate the *Limit switch* function (see chapter 7.5), then after the second time you press the OK key, the *MIN/MAX* menu option will immediately be shown.

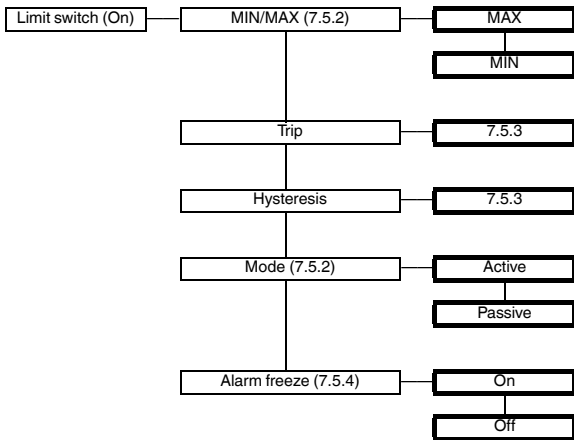

## 7.5.2 Operating Behaviour

Either *Max* or *Min* may be selected as operating behaviour; either *Active* or *Passive* may be selected as operating mode (see chapter 7.5.1). Range of application:

- Switching direction *MAX*, mode of operation *Active*: Alarm if trip value exceeded, for example buzzer on
- Switching direction *MAX*, mode of operation *Passive*: Overfill protection, monitoring of excessive RPM, for example pump/drive off; in case of large hysteresis MIN-MAX mode (on/off)
- Switching direction *MIN*, mode of operation *Active*: Alarm if trip value exceeded, for example buzzer on
- Switching direction *MIN*, mode of operation *Passive*: Overload protection, monitoring for low speed, for example pump off if there is no more flow

The exact operating behaviour of the device is shown in the following figure:

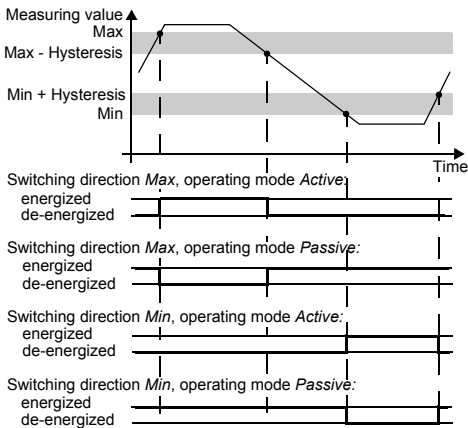

### 7.5.3 Switching Point and Hysteresis

When entering values for the switching point and hysteresis, please note:

- Both values should be entered in the unit that was selected under *Unit* (see chapter 7.2). Values can be entered between 0.001 Hz and 5000 Hz (for non-ex devices: 10 kHz). You can determine the input limits for a unit other than *Hz* by using the conversions given in chapter 7.2.
- Since the device internally converts all values into whole mHz (= 0.001 Hz), rounding errors may occur in values which you enter in rpm, r/sec, l/min, l/h, m<sup>3</sup>/h, km/h or m/s. If your application cannot tolerate these small variations in exceptional cases, then select the unit Hz.
- The hysteresis should be selected to be > 1 % of the switching point to prevent the relay from fluttering.
- As shown in the illustration of operational behaviour in chapter 7.5.2, in *MAX* operating mode, the switching point - hysteresis value must be > 0, while in the *MIN* operating mode, the value switching point + hysteresis ≤ upper limit switching point entry.

All these input limits are automatically assigned by the device.

### 7.5.4 Restart Inhibit

Restart inhibit prevents temporary trip value violations or line faults (*Err LB*, *Err SC*; see chapter 6 and chapter 7.3) from not being noticed by operations personnel.

- If *Alarm freeze On* has been selected, the new state is retained after an output is switched until one of the following actions takes place:
  - Device is restarted
  - Signal on terminals 13/14
  - *ESC* key pressed.

Each of these actions will cause the switch output to be reset unless the trip value has been violated or the lead fault is still present.

- If you have selected restart inhibit for an output with the switching direction *MIN*, start-up override must have been initiated when the device started up (see chapter 7.3.2). The device always starts with a 0 measurement value. This will immediately trigger a *MIN* alarm. Without start-up override, the output would then be blocked by restart inhibit.

Using the **PACT<sub>ware</sub>**<sup>TM</sup> parameterization software, pulse suppression can be selected as an alternative to start-up override (see chapter 7.3.2). If pulse suppression is selected in this manner, no restart inhibit is possible. If problems occur with the restart inhibit, please use the **PACT<sub>ware</sub>**<sup>TM</sup> software to check whether pulse suppression has been selected.

### 7.5.5 Serial Switching

To select this function, in the *serial switching* menu option, press the *OK* key twice. You can cancel after the first *OK* with *ESC*.

When serial switching is selected, input pulses are switched 1:1 to the switch output. Pulses can then be evaluated in the process control system/in the control unit. So in this function, the device is only an isolator between intrinsically safe and non-intrinsically safe circuits.

The maximum switching frequency at the transistor output is 5 kHz; at the relay < 2 Hz. The relays are thus only suitable as serial switching outputs in exceptional cases.

### 7.5.6 Pulse Divider

The following illustration shows the menu levels which follow the *Pulse divider* menu option. Menu items on the lowest level are outlined in bold.

If the *Pulse divider* function is activated (*On*), the *OK* key takes you from the *Pulse divider* menu options to the *Divider ratio* menu. When you first activate the *Pulse divider* function (see chapter 7.5), after the second press on the *OK* key, the *Divider ratio* is immediately shown.

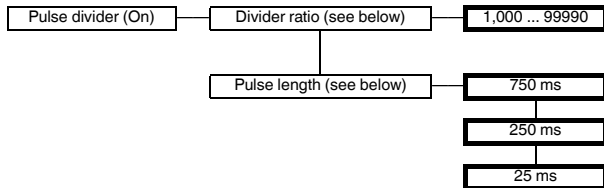

The number of input pulses is divided by the **divider ratio** and switched to the output. The relays can only be used in certain cases as signal divider outputs due to the maximum switching frequency < 2 Hz.

Meaning of **pulse length**: The switch output does not generate a constant frequency. Rather it generates a potentially irregularly occurring number of pulses per unit of time, a maximum of 10 pulses per second.

where the following must hold:

$$\text{Pulse length} < \frac{1}{4} \cdot \frac{\text{Pulse divider}}{\text{max. input frequency}}$$

Example:

- Maximum input frequency 4 kHz, pulse divider 2000
- The following must be true: Pulse length < 0.25 x 0.5 s = 0.125 s.
- Therefore 25 ms should be entered as pulse length.

### 7.5.7 Error Switch

The following illustration shows the menu levels which are accessible through the *Error switch* menu option. Menu items at the lowest level are outlined in bold.

If the *Error switch* function is activated (*On*), the OK key takes you from the *Error switch* menu option to the *Alarm freeze* menu option. When you activate the *Error switch* function (see chapter 7.5), then after the OK key is pressed the second time, the menu option *Alarm freeze* is immediately shown.

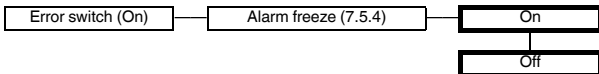

A switch output with the **Error switch** function is energized in normal operation. If the device encounters an error condition (see chapter 6), the switch output is switched off.

## 7.6 Current Output

The following illustration shows the menu levels which are accessible from the *Iout* menu option. Menu items on the lowest level are outlined in bold.

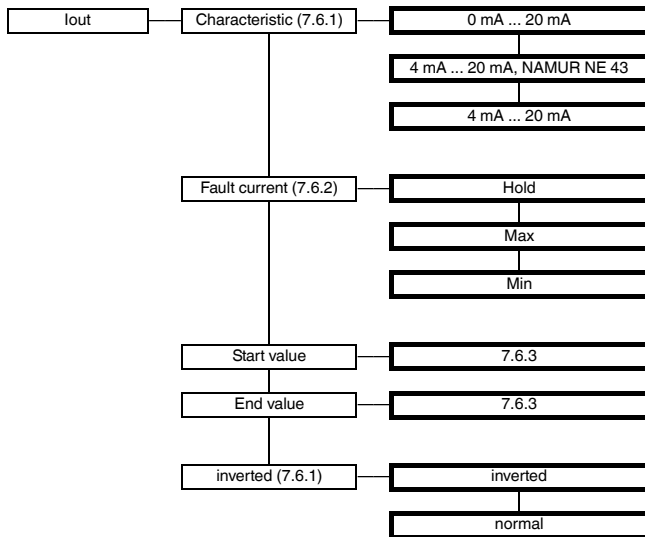

### 7.6.1 Current Path Characteristic

The various settings have the following meaning (for setting the starting value and final value, see chapter 7.6.3; if you select the inverted characteristic, the conversion of starting value and final value will be exchanged):

#### Setting 0 mA to 20 mA

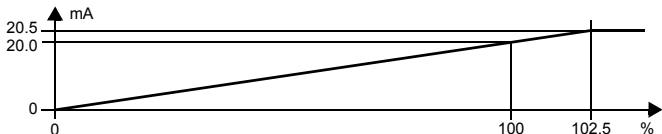

For this setting, the start value is converted to 0 mA and the final value to 20 mA. Intermediate values are converted proportional.

Values less than the start value cannot be evaluated (output 0 mA). With values greater than the end value, the output current increases linearly up to maximum 20.5 mA (102.5% of the measuring range). Additional overranges cannot be evaluated (output 20.5 mA).

#### Setting 4 mA to 20 mA, acc. NAMUR NE 43

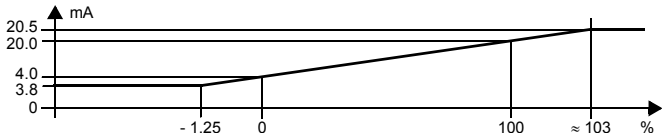

For this setting, the initial value is converted to 4 mA and the final value to 20 mA. Intermediate values are converted proportional.

If the value falls lower than the start value, the output current falls linearly to a minimum of 3.8 mA (-1.25% of the measurement range). Additional underranges cannot be evaluated (output 3.8 mA). If the final value is exceeded, the output current rises linearly to a maximum of 20.5 mA (roughly 103% of the measurement range). Additional overranges cannot be evaluated (output 20.5 mA).

### Setting 4 mA to 20 mA

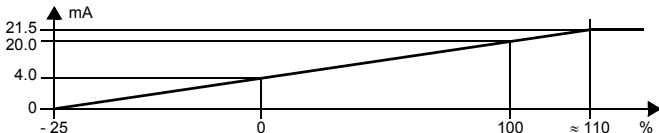

For this setting, the initial value is converted to 4 mA and the final value to 20 mA. Intermediate values are converted proportional.

If the value falls below the start value, the output current falls linearly to 0 mA (- 25 % of the measurement range). Additional underranges cannot be evaluated (output 0 mA).

If the final value is exceeded, the output current rises linearly to about 21.5 mA (roughly 110 % of the measurement range). Additional overranges cannot be evaluated (output 21.5 mA).

### 7.6.2 Fault Current

The following table shows what the result of the current output is depending on the setting in the event of a malfunction:

Setting	Current path characteristic 0 mA to 20 mA	Current path characteristic 4 mA to 20 mA, acc. NAMUR NE 43	Characteristic 4 mA to 20 mA
<b>hold</b>	last measured value before fault occurred		
<b>Max (upscale)</b>	approx. 21.5 mA	approx. 21.5 mA	approx. 21.5 mA (indistinguishable from overlimit of final value)
<b>Min (downscale)</b>	0 mA (indistinguishable from underlimit of starting value)	2.0 mA	2.0 mA (indistinguishable from overlimit of final value)

### 7.6.3 Start Value and Final Value

During entry of start and final value, please note:

- Values should be entered in the selected units (see chapter 7.2).
- Values can be entered between 0.001 Hz and 5000 Hz (for non-Ex devices: 10 kHz). You can determine the input limits for a unit other than Hz by using the conversions that are given in chapter 7.2.
- Since the device converts all values into whole mHz (= 0.001 Hz), rounding errors may occur in values which you enter in rpm, r/sec, l/min, l/h, m<sup>3</sup>/h, km/h or m/s. If your application cannot tolerate this small variance in exceptional cases, please select the unit Hz.
- The difference between the final value and the start value should be greater than 1% of the end value.

### 7.7 Service

The following illustration shows the menus for the service parameters. Menu items on the lowest level are outlined in bold.

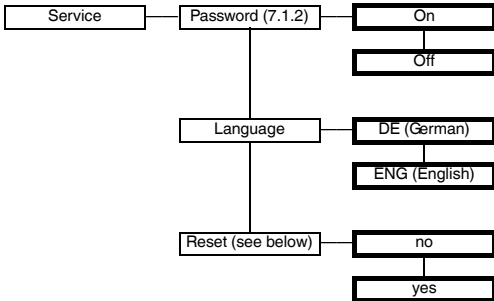

**Reset:** If the value yes is shown flashing and you press the OK key, all parameters in the device will be reset to their factory settings. All entries you have ever made in parameterization mode will be lost.



# PROCESS AUTOMATION – PROTECTING YOUR PROCESS



## Worldwide Headquarters

Pepperl+Fuchs GmbH  
68307 Mannheim · Germany  
Tel. +49 621 776-0  
E-Mail: [info@de.pepperl-fuchs.com](mailto:info@de.pepperl-fuchs.com)

For the Pepperl+Fuchs representative  
closest to you check [www.pepperl-fuchs.com/contact](http://www.pepperl-fuchs.com/contact)

[www.pepperl-fuchs.com](http://www.pepperl-fuchs.com)

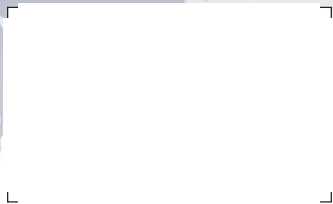

 **PEPPERL+FUCHS**  
*PROTECTING YOUR PROCESS*



# SCATTERGOOD & JOHNSON LTD

ELECTRICAL ENGINEERING & FLUID CONTROL DISTRIBUTORS

Est.1899

At Scattergood & Johnson Ltd, we pride ourselves on being a technical distributor to specialist industries.

Working with a range of quality product suppliers across a number of specialist markets, we are not your average 'box shifter' - we are your technical and supply chain partner.

We fully support every product we sell - for free! Our internal team and external sales engineers can answer any product or application question, no matter the complexity.

Backing up this technical ability is a range of 50,000+ products available from stock for nationwide next day delivery (same day if required!), or you can collect what you need from any of our trade counters around the UK.

Select your specialist interest below to learn more about how we can help.

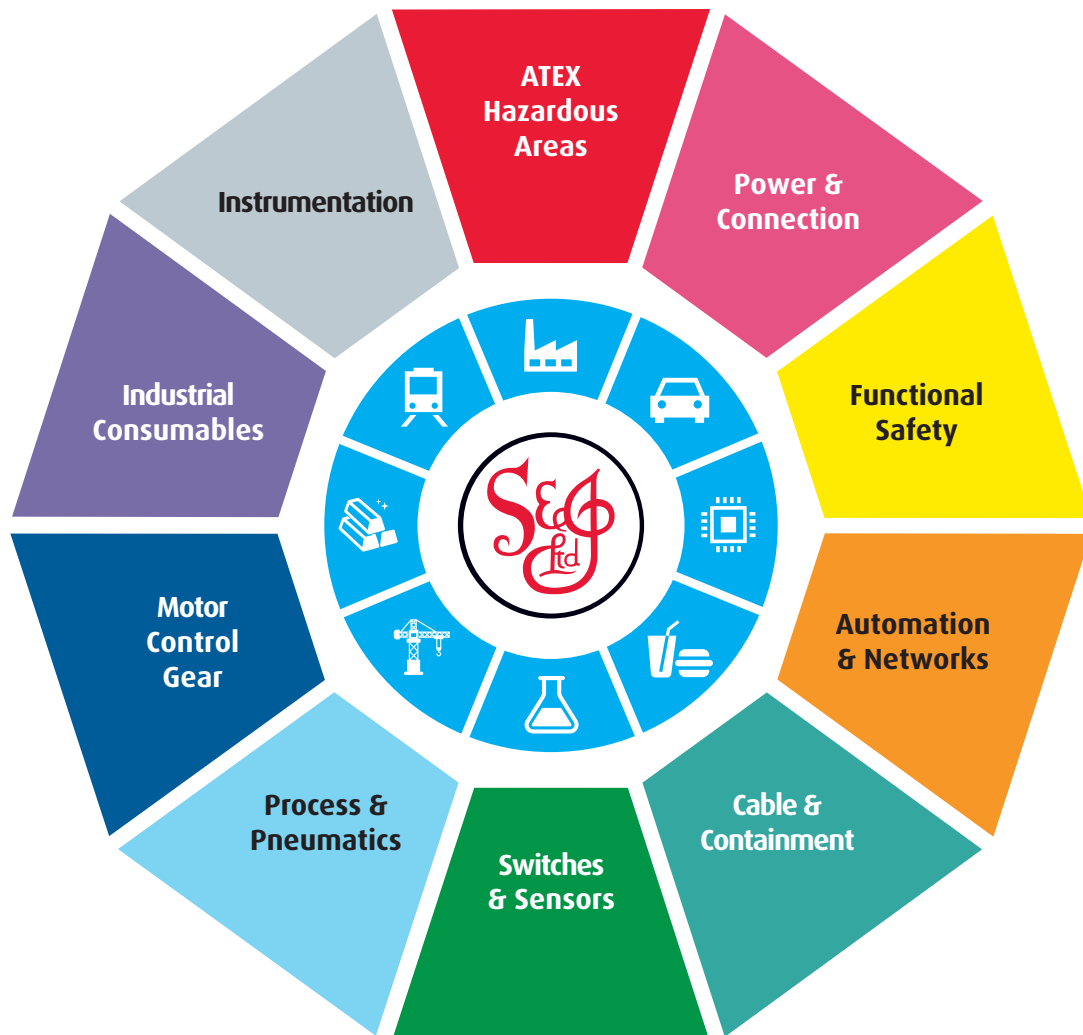

Online, In Branch and On the Road - Scattergood & Johnson Ltd, there when you need us.

# [www.scatts.co.uk](http://www.scatts.co.uk)