

Features

- 1-channel signal conditioner
- 24 V DC supply (Power Rail)
- Thermocouple, RTD, potentiometer or voltage input
- Current output 0/4 mA ... 20 mA
- Sink or source mode
- Configurable by PACTware
- Line fault (LFD) and sensor burnout detection
- Up to SIL 2 acc. to IEC 61508/IEC 61511

Function

This signal conditioner provides the galvanic isolation between field circuits and control circuits.

The device converts the signal of a resistance thermometer, thermocouple, or potentiometer to a proportional output current.

The device can also be configured as a signal splitter.

The removable terminal block K-CJC-** is available as an accessory for internal cold junction compensation of thermocouples.

A fault is signaled by LEDs acc. to NAMUR NE44 and a separate collective error message output.

The device is easily configured by the use of the PACTware configuration software.

For additional information, refer to the manual and www.pepperl-fuchs.com.

Assembly

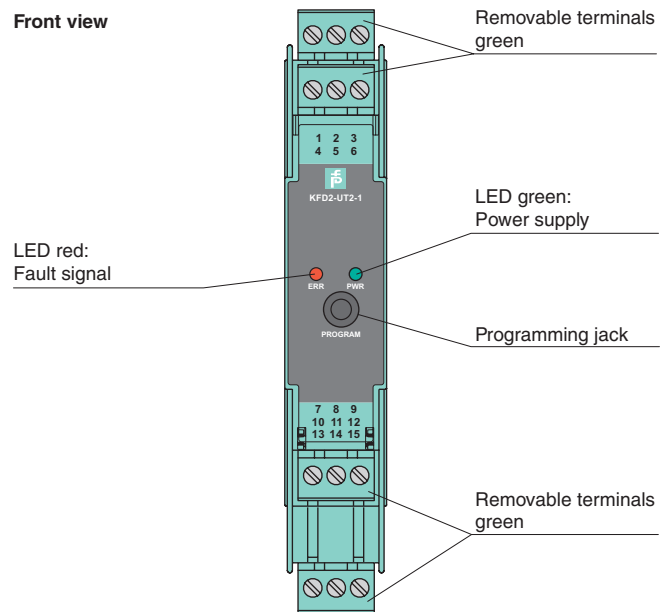

CE

SIL 2

Connection

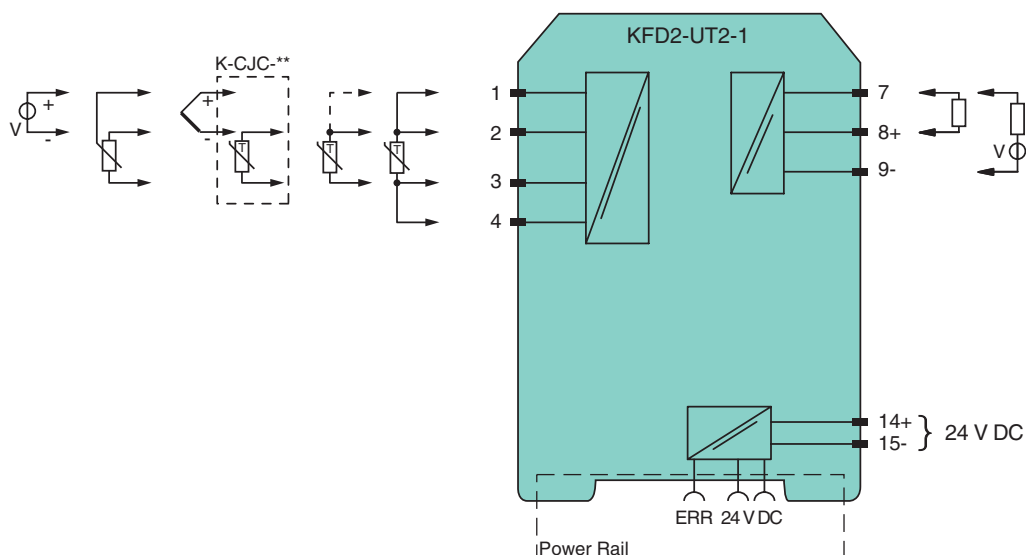

General specifications	
Signal type	Analog input
Functional safety related parameters	
Safety Integrity Level (SIL)	SIL 2
Supply	
Connection	terminals 14+, 15- or power feed module/Power Rail
Rated voltage U_r	20 ... 30 V DC
Ripple	within the supply tolerance
Power dissipation/power consumption	$\leq 0.98 \text{ W} / 0.98 \text{ W}$
Interface	
Programming interface	programming socket
Input	
Connection side	field side
Connection	terminals 1, 2, 3, 4
RTD	type Pt10, Pt50, Pt100, Pt500, Pt1000 (EN 60751: 1995) type Pt10GOST, Pt50GOST, Pt100GOST, Pt500GOST, Pt1000GOST (6651-94) type Cu10, Cu50, Cu100 (P50353-92) type Ni100 (DIN 43760)
Measuring current	approx. 200 μA with RTD
Types of measuring	2-, 3-, 4-wire connection
Lead resistance	$\leq 50 \Omega$ per line
Measurement loop monitoring	sensor breakage, sensor short-circuit
Thermocouples	type B, E, J, K, N, R, S, T (IEC 584-1: 1995) type L (DIN 43710: 1985) type TXK, TXKH, TXA (P8.585-2001)
Cold junction compensation	external and internal
Measurement loop monitoring	sensor breakage
Potentiometer	0 ... 20 k Ω (2-wire connection), 0.8 ... 20 k Ω (3-wire connection)
Voltage	selectable within the range -100 ... 100 mV
Input resistance	$\geq 1 \text{ M}\Omega$ (-100 ... 100 mV)
Output	
Connection side	control side
Connection	output I: terminal 7: source (-), sink (+), terminal 8: source (+), terminal 9: sink(-)
Output	Analog current output
Current range	0 ... 20 mA or 4 ... 20 mA
Fault signal	downscale 0 or 2 mA, upscale 21.5 mA (acc. NAMUR NE43)
Source	load 0 ... 550 Ω open-circuit voltage $\leq 18 \text{ V}$
Sink	Voltage across terminals 5 ... 30 V. If the current is supplied from a source $> 16.5 \text{ V}$, series resistance of $\geq (V - 16.5)/0.0215 \Omega$ is needed, where V is the source voltage. The maximum value of the resistance is $(V - 5)/0.0215 \Omega$.
Transfer characteristics	
Deviation	
After calibration	Pt100: $\pm (0.06 \%$ of measurement value in K $+ 0.1 \%$ of span $+ 0.1 \text{ K}$ (4-wire connection)) thermocouple: $\pm (0.05 \%$ of measurement value in $^{\circ}\text{C} + 0.1 \%$ of span $+ 1 \text{ K}$ (1.2 K for types R and S)) this includes $\pm 0.8 \text{ K}$ error of the cold junction compensation mV: $\pm (50 \mu\text{V} + 0.1 \%$ of span) potentiometer: $\pm (0.05 \%$ of full scale $+ 0.1 \%$ of span, (excludes errors due to lead resistance))
Influence of ambient temperature	deviation of CJC included: Pt100: $\pm (0.0015 \%$ of measurement value in K $+ 0.006 \%$ of span)/K $\Delta T_{\text{amb}}^{\text{*)}$ thermocouple: $\pm (0.02 \text{ K} + 0.005 \%$ of measurement value in $^{\circ}\text{C} + 0.006 \%$ of span)/K $\Delta T_{\text{amb}}^{\text{*)}$ mV: $\pm (0.01 \%$ of measurement value $+ 0.006 \%$ of span)/K $\Delta T_{\text{amb}}^{\text{*)}$ potentiometer: $\pm 0.006 \%$ of span/K $\Delta T_{\text{amb}}^{\text{*)}$ $\text{*) } \Delta T_{\text{amb}}$ = ambient temperature change referenced to 23 $^{\circ}\text{C}$ (296 K)
Influence of supply voltage	$< 0.01 \%$ of span
Influence of load	$\leq 0.001 \%$ of output value per 100 Ω
Reaction time	worst case value (sensor breakage and/or sensor short circuit detection enabled) mV: 1 s, thermocouples with CJC: 1.1 s, thermocouples with fixed reference temperature: 1.1 s, 3- or 4-wire RTD: 920 ms, 2-wire RTD: 800 ms, Potentiometer: 2.05 s
Galvanic isolation	
Input/Other circuits	basic insulation according to IEC 61010-1, rated insulation voltage 300 V _{eff}
Output/supply, programming input	functional insulation, rated insulation voltage 50 V AC There is no electrical isolation between the programming input and the supply. The programming cable provides galvanic isolation so that ground loops are avoided.
Indicators/settings	
Display elements	LEDs
Configuration	via PACTware
Labeling	space for labeling at the front

Release date 2019-11-25 12:04 Date of issue 2019-11-25 248759_eng.xml

Refer to "General Notes Relating to Pepperl+Fuchs Product Information".

Directive conformity	
Electromagnetic compatibility	
Directive 2014/30/EU	EN 61326-1:2013 (industrial locations)
Conformity	
Electromagnetic compatibility	NE 21:2006
Degree of protection	IEC 60529:2001
Ambient conditions	
Ambient temperature	-20 ... 60 °C (-4 ... 140 °F)
Mechanical specifications	
Degree of protection	IP20
Connection	screw terminals
Mass	approx. 130 g
Dimensions	20 x 119 x 115 mm (0.8 x 4.7 x 4.5 inch) , housing type B2
Mounting	on 35 mm DIN mounting rail acc. to EN 60715:2001
General information	
Supplementary information	Observe the certificates, declarations of conformity, instruction manuals, and manuals where applicable. For information see www.pepperl-fuchs.com .
Accessories	
Optional accessories	<ul style="list-style-type: none"> - power feed module KFD2-EB2(.R4A.B)(.SP) - universal power rail UPR-03(-M)(-S) - profile rail K-DUCT-GY(-UPR-03) - FDT framework PACTware 5.X - device type manager DTM Interface Technology - adapter K-ADP-USB



SCATTERGOOD & JOHNSON LTD

ELECTRICAL ENGINEERING & FLUID CONTROL DISTRIBUTORS

Est.1899

At Scattergood & Johnson Ltd, we pride ourselves on being a technical distributor to specialist industries.

Working with a range of quality product suppliers across a number of specialist markets, we are not your average 'box shifter' - we are your technical and supply chain partner.

We fully support every product we sell - for free! Our internal team and external sales engineers can answer any product or application question, no matter the complexity.

Backing up this technical ability is a range of 50,000+ products available from stock for nationwide next day delivery (same day if required!), or you can collect what you need from any of our trade counters around the UK.

Select your specialist interest below to learn more about how we can help.



Online, In Branch and On the Road - Scattergood & Johnson Ltd, there when you need us.

www.scatts.co.uk