

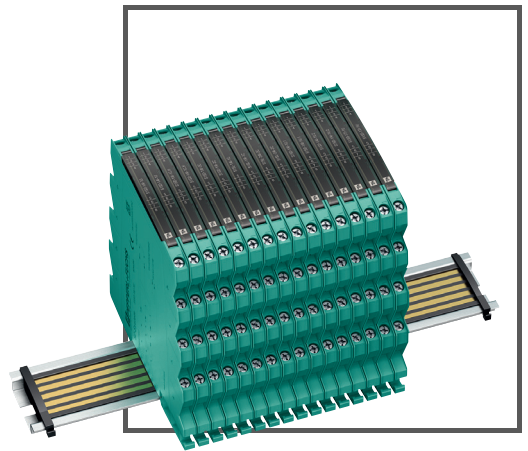

MANUAL

SC-System Signal Conditioner





With regard to the supply of products, the current issue of the following document is applicable: The General Terms of Delivery for Products and Services of the Electrical Industry, published by the Central Association of the Electrical Industry (Zentralverband Elektrotechnik und Elektroindustrie (ZVEI) e.V.) in its most recent version as well as the supplementary clause: "Expanded reservation of proprietorship"

1	Introduction	4
1.1	Content of this Document.	4
1.2	Target Group, Personnel	4
1.3	Symbols Used	5
2	Product Specifications	6
2.1	Function	6
2.2	Housing Style	7
2.3	Connections	7
2.4	Status Indicators of the Isolators	8
2.5	Label Carrier	9
3	Installation	10
3.1	DIN Mounting Rail	10
3.2	Power Bus	10
3.3	Mounting	12
3.4	Connection	14
3.5	Device Configuration	20
4	Operation	22
4.1	Fault Monitoring	22
4.2	Fault Output	22
4.3	Current and Voltage Standard Signals	23
5	Dismounting, Maintenance, and Repair	24
6	Technical Specifications	26
6.1	Technical Data	26
6.2	Model Number Description	28
6.3	Dimensions	29

1 Introduction

1.1 Content of this Document

This document contains information that you need in order to use your product throughout the applicable stages of the product life cycle. These can include the following:

- Product identification
- Delivery, transport, and storage
- Mounting and installation
- Commissioning and operation
- Maintenance and repair
- Troubleshooting
- Dismounting
- Disposal



Note

This document does not substitute the instruction manual.



Note

For full information on the product, refer to the instruction manual and further documentation on the Internet at www.pepperl-fuchs.com.

The documentation consists of the following parts:

- Present document
- Instruction manual
- Datasheet

Additionally, the following parts may belong to the documentation, if applicable:

- EU-type examination certificate
- EU declaration of conformity
- Attestation of conformity
- Certificates
- Control drawings
- Additional documents

1.2 Target Group, Personnel

Responsibility for planning, assembly, commissioning, operation, maintenance, and dismantling lies with the plant operator.

Only appropriately trained and qualified personnel may carry out mounting, installation, commissioning, operation, maintenance, and dismantling of the product. The personnel must have read and understood the instruction manual and the further documentation.

Prior to using the product make yourself familiar with it. Read the document carefully.

1.3 Symbols Used

This document contains symbols for the identification of warning messages and of informative messages.

Warning Messages

You will find warning messages, whenever dangers may arise from your actions. It is mandatory that you observe these warning messages for your personal safety and in order to avoid property damage.

Depending on the risk level, the warning messages are displayed in descending order as follows:



Danger!

This symbol indicates an imminent danger.

Non-observance will result in personal injury or death.



Warning!

This symbol indicates a possible fault or danger.

Non-observance may cause personal injury or serious property damage.



Caution!

This symbol indicates a possible fault.

Non-observance could interrupt the device and any connected systems and plants, or result in their complete failure.

Informative Symbols



Note

This symbol brings important information to your attention.



Action

This symbol indicates a paragraph with instructions. You are prompted to perform an action or a sequence of actions.

2 Product Specifications

2.1 Function

Signal conditioners provide the isolation for non-intrinsically safe applications. They have the necessary current and voltage limitation between field circuit and control.

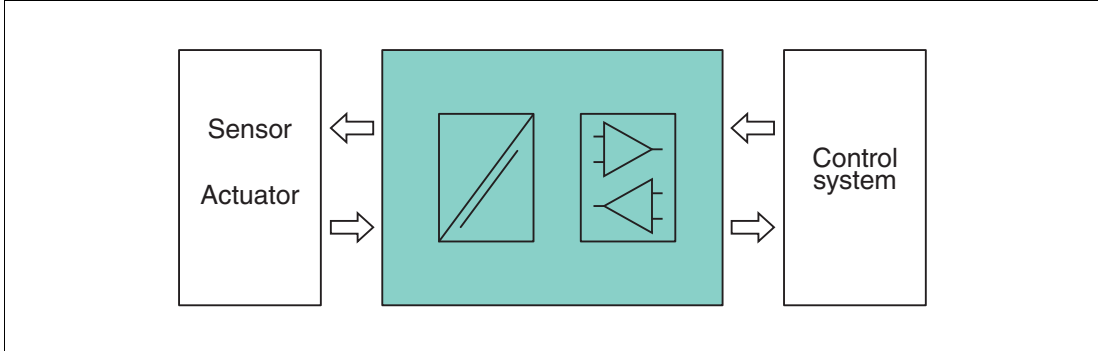

Figure 2.1 Function – isolating, amplifying and transforming signals

The SC-System consists of a range of signal conditioners suitable for mounting on 35 mm DIN mounting rail. SC-System is easy to specify, integrate and expand. The product line of signal conditioners contains different models, each containing industry leading features and benefits.

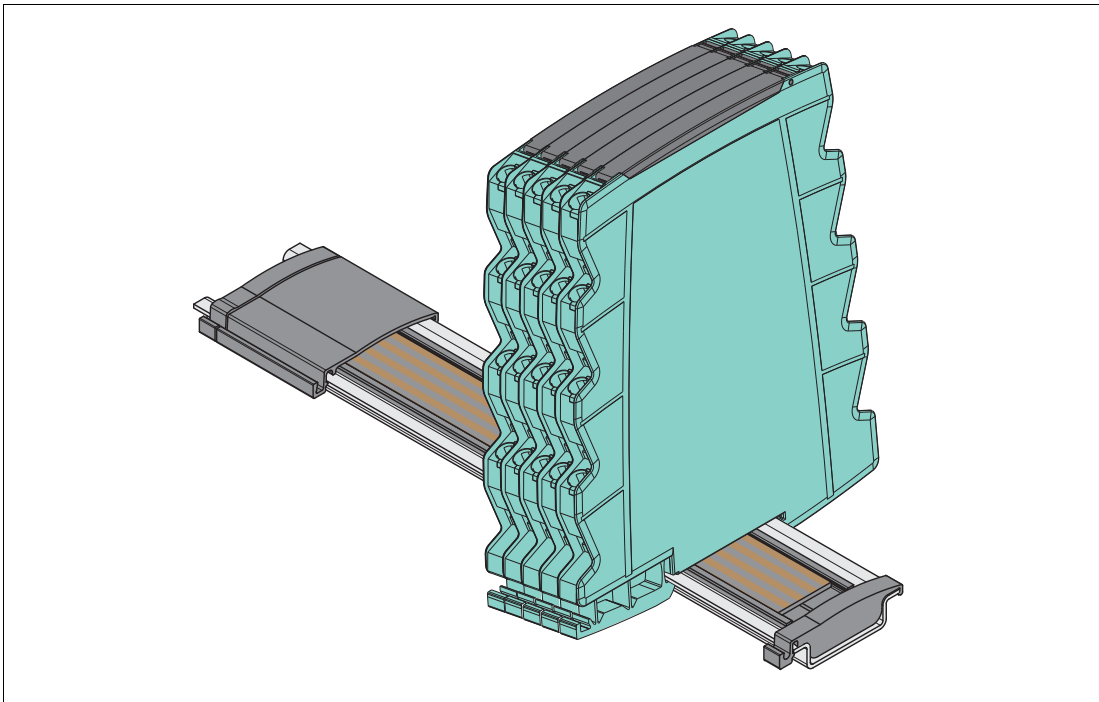

Figure 2.2 SC-System on DIN mounting rail with Power Bus

2.2 Housing Style

Regardless of the functionality and application, SC-System devices have a housing width of 6.2 mm.

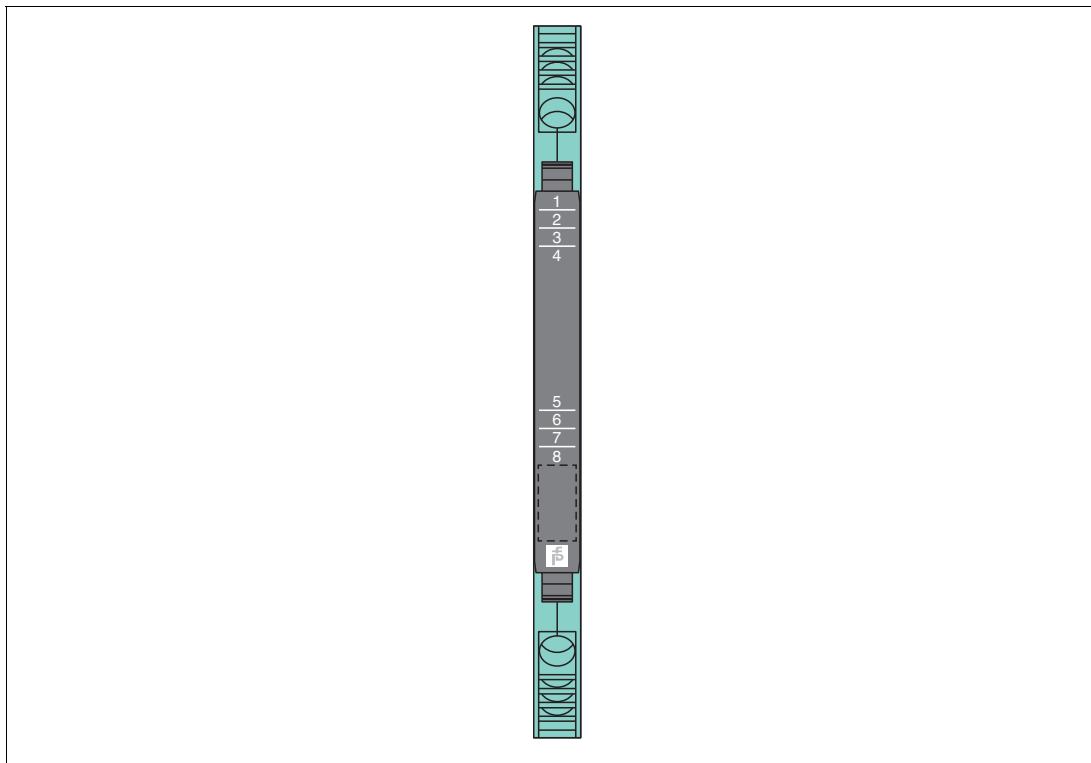

Figure 2.3 SC-System device housing (6.2 mm)

Used for high signal integrity

- Compact 6.2 mm housing
- Maximum packing density with single loop integrity
- Power dissipation only 0.8 W per device

2.3 Connections

The terminals are designed as screw terminals or spring terminals. The terminals offer a space for the connection of conductors with core cross-sections of up to 2.5 mm² (14 AWG).

The device has contacts on the bottom for the optional connection to the Power Bus. See chapter 3.2.



Note

See corresponding datasheets for further information.

2.4 Status Indicators of the Isolators

LEDs are often used on isolators to indicate different statuses (e. g. for power supply, device failure, status messages, binary switching states). Standard LED colors are assigned to the status display according to NAMUR NE44.

LED	Display function	Display	Meaning
Green LED	Power supply	On	Power supply OK
		Off	No power supply or insufficient power supply – device faulty
Red LED	Device fault, device failure	On	Internal fault signal, failure signal – fault/failure display of causes detected inside the device, device needs replacing
	Line fault	Flashing	External fault signal, failure signal – fault/failure display of causes detected outside the device, inspection and elimination of fault required
	No fault	Off	No malfunction, device is operating properly
Yellow LED	Switching states of binary inputs and outputs	On	Possible causes of the output: <ul style="list-style-type: none"> • The relay is energized. • The NO contact (also a change-over contact) is actively closed. • The open collector is switched through. • The switching voltage generated inside the device is applied. Possible causes of the input: <ul style="list-style-type: none"> • A binary switching signal is present. • An analog limit value is reached.
		Off	Possible causes of the output: <ul style="list-style-type: none"> • The relay is de-energized. • The NO contact (also a change-over contact) is actively opened. • The open collector is not switched through. • The switching voltage generated inside the device is not applied. Possible causes of the input: <ul style="list-style-type: none"> • A binary switching signal is present. • An analog limit value is reached.

Table 2.1 Meaning of status indicators

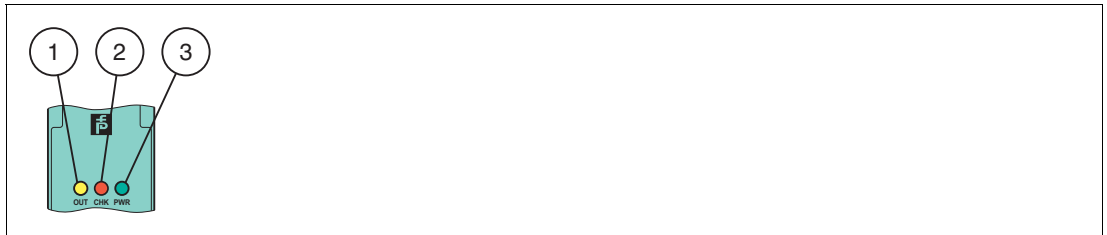

Figure 2.4 Example status indicators

- 1 Yellow LED "OUT"
Switching state of the output
- 2 Red LED "CHK"
Lead breakage and short circuit status indicator
- 3 Green LED "PWR"
Power supply status indicator

2.5 Label Carrier

The device has a label carrier on the front side for individual marking.

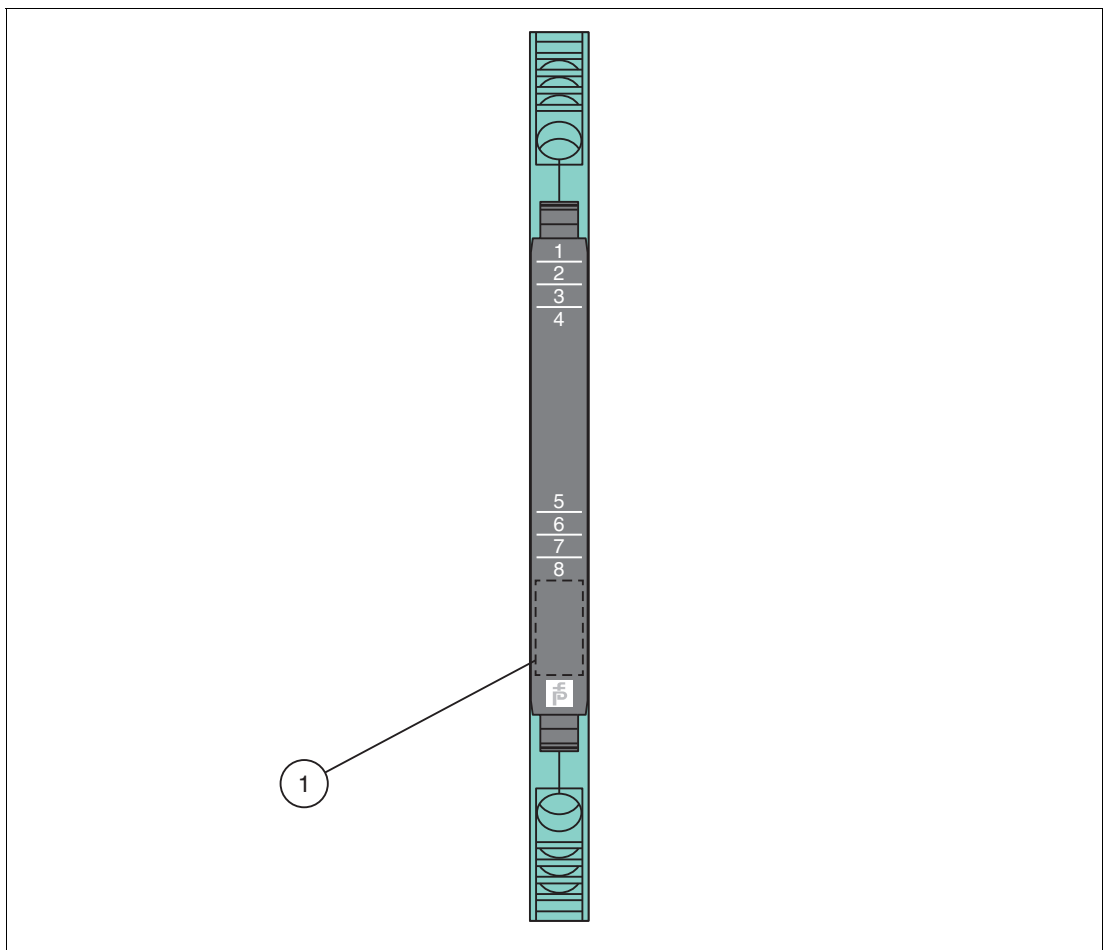

Figure 2.5 Label carrier on the front side

- 1 Label carrier for 10 mm x 5 mm labels

3 Installation

3.1 DIN Mounting Rail

The devices are mounted on a 35 mm DIN mounting rail according to EN 60715.

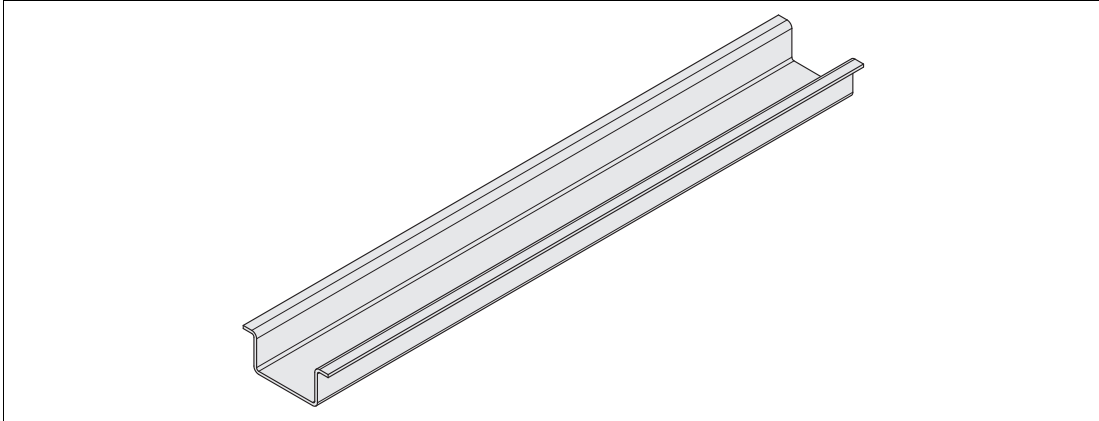

Figure 3.1 Example: DIN mounting rail (35 mm x 15 mm)

3.2 Power Bus

To reduce wiring and installation costs, Power Bus is the optimum solution.

The Power Bus consists of a carrier profile with bus PCB and two end caps. In addition, two end caps are attached to the Power Bus.

The Power Bus is inserted into the DIN mounting rail, delivers power to all devices (24 V DC).

The Power Bus simplifies expansion – just snap in a new isolator when you're ready to expand a system.

The Power Bus comes in standard segments but can be cut to any size.

Cover empty, open segments of the Power Bus. Use the supplied cover for DIN mounting rail (optional accessory). Thereby Power Bus will be protected from pollution. The contact with electrically conductive parts on power bus will be prevented.

Power Bus is available in two versions:

- **POWERBUS-SETH5.XXX**
Carrier profile with bus PCB for 35 mm DIN mounting rail, height 15 mm
- **POWERBUS-SETL5.XXX**
Carrier profile with bus PCB for 35 mm DIN mounting rail, height 7.5 mm

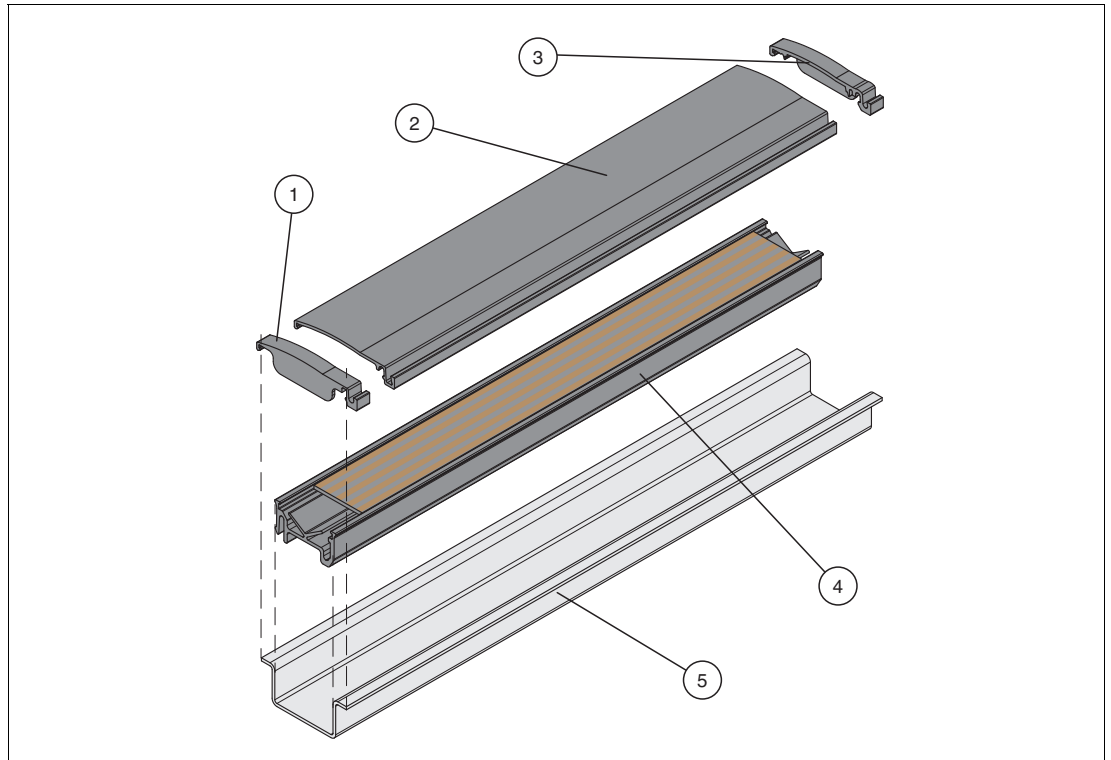

Figure 3.2 Example: Power Bus POWERBUS-SETH5.250

- 1 Left end cap POWERBUS-CAP
- 2 Cover for DIN mounting rail POWERBUS-COV.250
- 3 Right end cap POWERBUS-CAP
- 4 Carrier profile with bus PCB
- 5 35 mm DIN mounting rail according to EN 60715



3.3 Mounting

Mounting in the Non-Hazardous Area



Mounting the Device

Snap the device onto the DIN mounting rail. See figure below.

↳ If you mount the device on the DIN mounting rail without Power Bus, the contacts at the bottom of the device are exposed. These contacts must not be covered or protected specifically.

Mounting in Zone 2

For mounting in the hazardous area observe the following warning messages.



Danger!

Explosion hazard from live wiring of circuits

If you connect or disconnect energized circuits in a potentially explosive atmosphere, sparks can ignite the surrounding atmosphere.

Only connect or disconnect energized circuits in the absence of a potentially explosive atmosphere.



Danger!

Explosion hazard from wrong mounting

The device safety can be impaired by external environmental influences and by mechanical stress. That can lead to sparking that can ignite a surrounding potentially explosive atmosphere.

Mount the device in a surrounding enclosure that complies with IEC/EN 60079-0 and that is rated with the degree of protection IP54 according to IEC/EN 60529.



Mounting the Device

Snap the device onto the DIN mounting rail. See figure below.

↳ If you mount the device on the DIN mounting rail without Power Bus, the contacts at the bottom of the device are exposed. These contacts must not be covered or protected specifically.

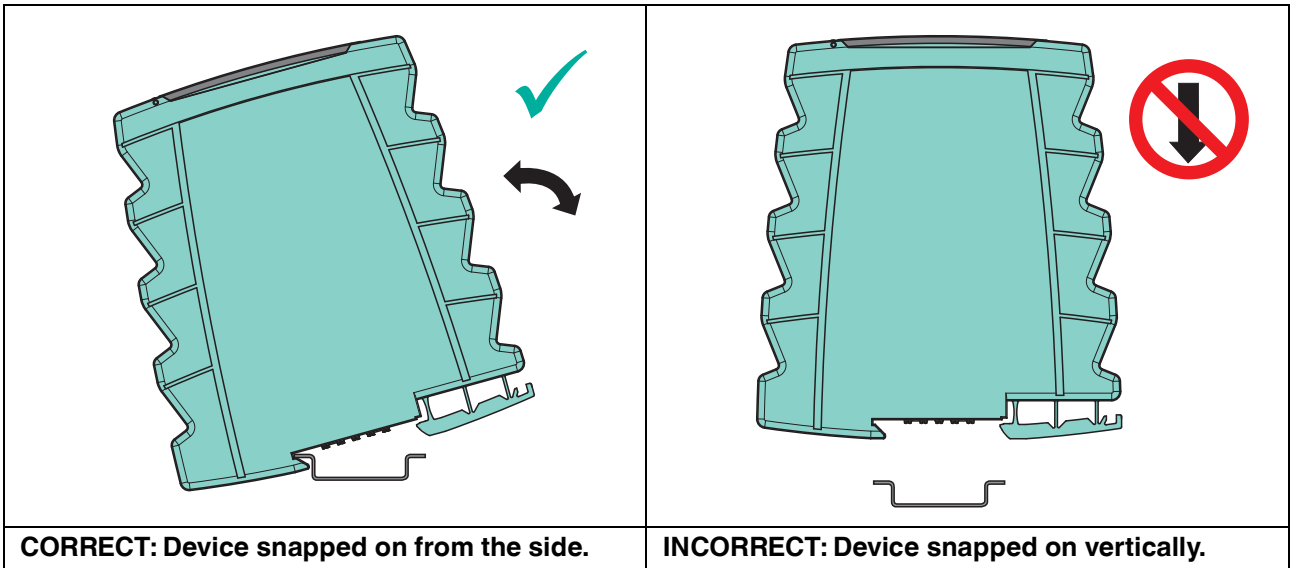

Figure 3.3

Vertical and horizontal mounting

Low heat dissipation allows vertical or horizontal mounting without spacing.
Operation is guaranteed over the full temperature range of the system in any mounting direction and without restriction.

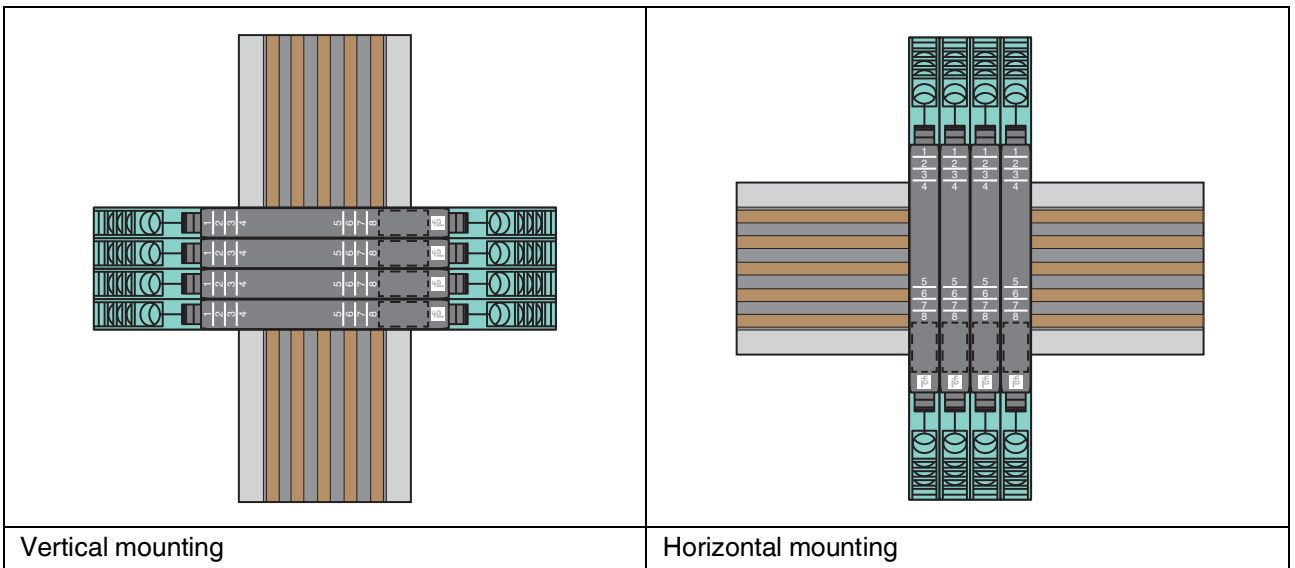

Figure 3.4

3.4 Connection



Danger!

Explosion hazard from live wiring of circuits

If you connect or disconnect energized circuits in a potentially explosive atmosphere, sparks can ignite the surrounding atmosphere.

Only connect or disconnect energized circuits in the absence of a potentially explosive atmosphere.



Danger!

Danger to life from electric shock

Absent or insufficient insulation can result in electric shock.

- Maintain sufficient distance between the connection lines, terminals, surrounding enclosure, and the environment.
- Insulate connection lines, terminals, and the surrounding enclosure from the environment.



Danger!

Danger to life from electric shock

Absent or insufficient insulation can result in electric shock.

Only connect supplies that provide protection against electric shock (e. g. SELV or PELV).



Danger!

Danger to life from electric shock

Working on live parts at voltages higher than 50 V AC or 120 V DC can result in electric shock.

1. De-energize the device.
2. Secure the circuit against reconnection.
3. Verify that the device is de-energized at all poles.
4. Provide protection from adjacent live parts, if present.



Danger!

Danger to life from incorrect installation

Incorrect installation of cables and connection lines can compromise the function and the electrical safety of the device.

- Observe the permissible core cross section of the conductor.
- When using stranded conductors, crimp wire end ferrules on the conductor ends.
- Use only one conductor per terminal.
- When installing the conductors the insulation must reach up to the terminal.
- Observe the tightening torque of the terminal screws.

**Warning!**

Risk of injury from wrong or missing fuse protection of supply

Faulty or missing fuse protection can compromise the function and the electrical safety of the device.

Protect the supply with a suitable fuse protection.

**Caution!**

Property damage from use of inappropriate tool

Using an inappropriate tool may damage the screw heads.

- Only use the following screwdrivers:
 - Flat-head screwdriver 4 x 0.8
 - Phillips screwdriver PH1
- Only use M3.5 plus-minus screws for the terminals.

**Connecting Circuits**

1. Connect the field circuit.
2. Connect the control circuit.
3. Connect the power supply.
The devices can be supplied without Power Bus or with Power Bus.
4. Protect the power supply by a back-up fuse. See also next sections.
5. Make sure that the back-up fuse triggers in the event of a fault.

**Note**

See corresponding datasheets for further information.

3.4.1 Power Supply without Power Bus

Conventional power supplies create complicated and expensive wiring systems. After all isolated barriers are connected, there is a significant amount of wiring and more wiring must be added for extra functions such as line fault detection. The power supply must be protected by a 4 AT back-up fuse.

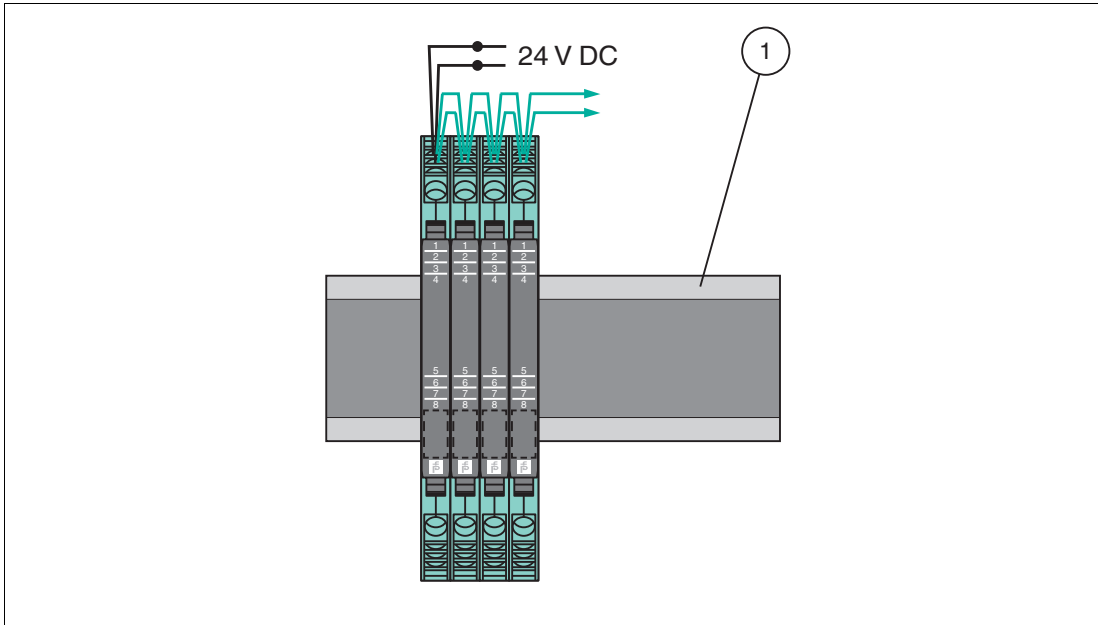

Figure 3.5 Conventional installation

- 1 DIN mounting rail

3.4.2 Power Supply via Power Bus

Using the Power Bus for devices with a 24 V DC supply voltage reduces wiring and installation costs. The Power Bus virtually eliminates the risk of wiring faults and facilitates subsequent extension.

The 24 V DC supply voltage is provided via an isolator or via power feed modules in the Power Bus.

The power supply must be protected by a back-up fuse. This back-up fuse ensures that the Power Bus and connection contacts are protected. It prevents damage caused by reverse supply voltage or by installing too many isolators.

Non-Redundant Supply via an Isolator

The Power Bus can be supplied via an isolator. The maximum supply current must not exceed 500 mA. Depending on the power consumption, the isolator can supply around 10 devices. The power supply must be protected by a 630 mA back-up fuse.

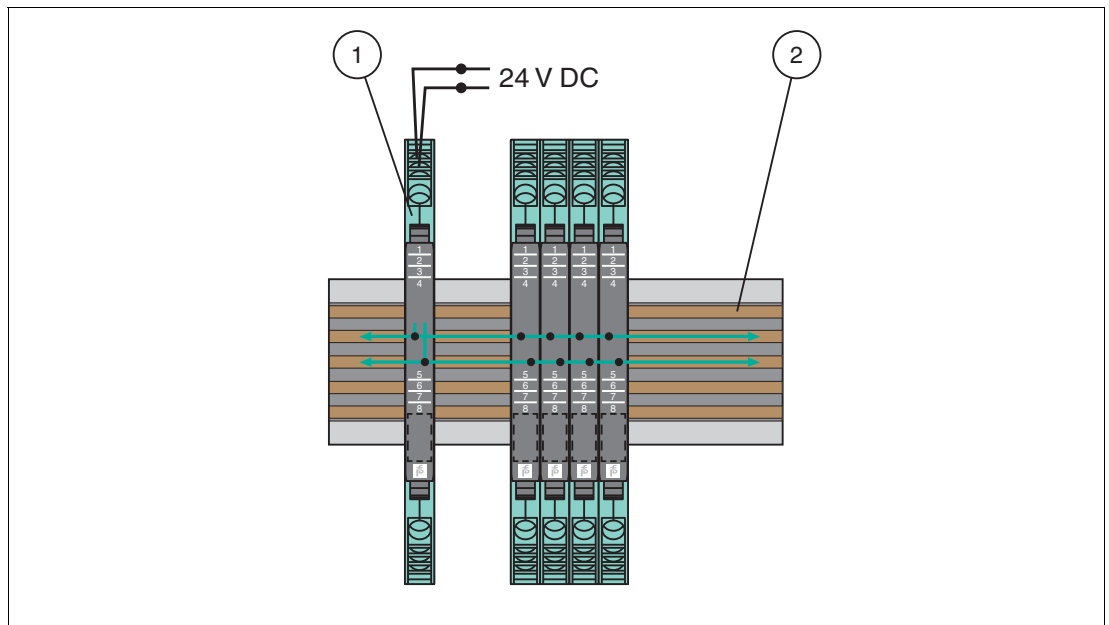

Figure 3.6 Non-redundant supply with isolator

- 1 Isolator
- 2 Power Bus

Non-Redundant Supply via a Power Feed Module

The power bus can be supplied via a power feed module. The maximum supply current, the number of isolators, and the external protection must not exceed the values specified in the datasheet. The power supply must be protected by a back-up fuse.

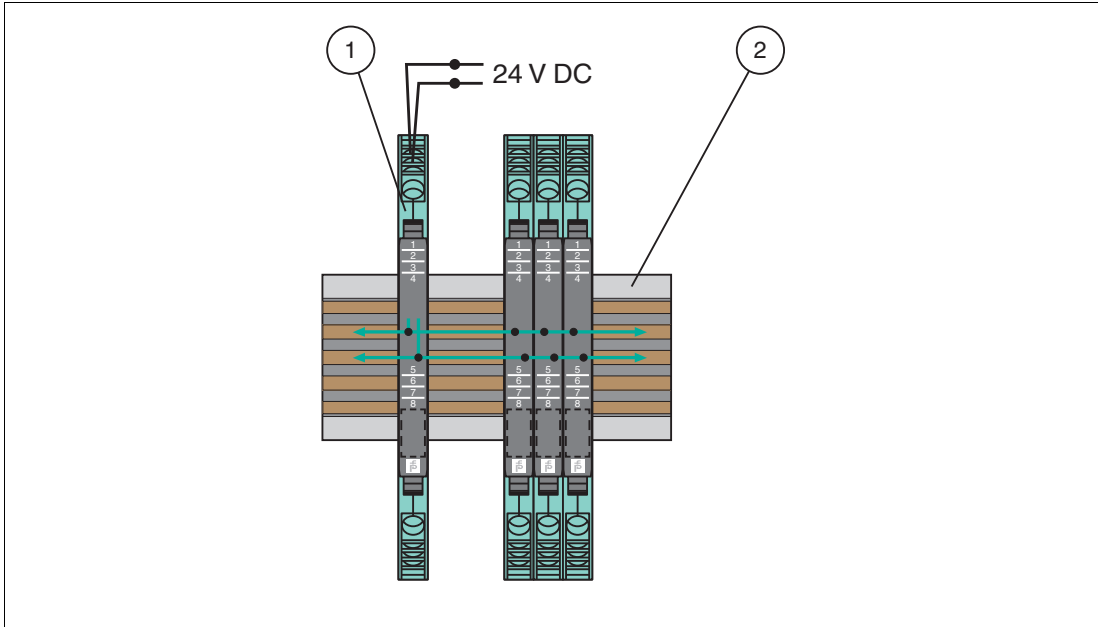

Figure 3.7 Non-redundant supply with power feed module

- 1 Power feed module
- 2 Power Bus

Redundant Supply with Power Feed Modules

Using two power supplies or providing a redundant power supply via two power feed modules delivers a high level of availability. If a power supply fails, the redundant power supply continues to provide the isolators with power via the Power Bus connection.

The maximum supply current, the number of isolators, and the external protection must not exceed the values specified in the datasheet. The power supply must be protected by one back-up fuse per power feed module.

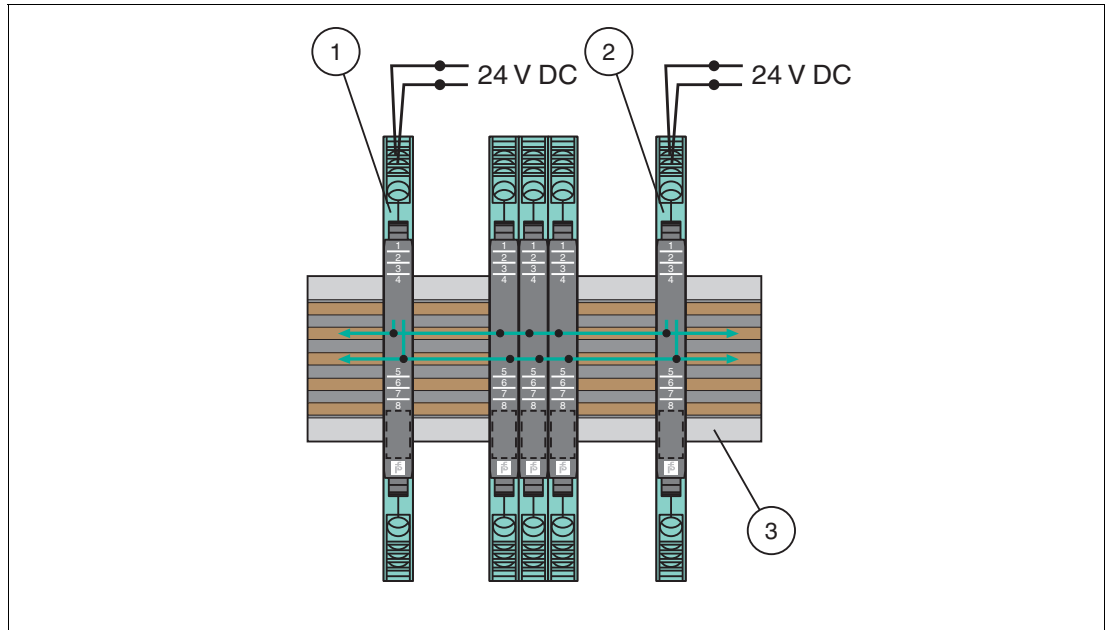

Figure 3.8 Redundant supply with power feed modules

- 1 Power feed module 1
- 2 Power feed module 2
- 3 Power Bus

3.5 Device Configuration

Many devices of the SC-System can be adapted to different applications. Depending on the device different controls are available for this configuration.



Danger!

Explosion hazard from sparking when using operating elements

Using operating elements in a potentially explosive atmosphere can cause sparks that can ignite the surrounding atmosphere.

Only use operating elements (e. g., switch, slider, button, etc.) in the absence of a potentially explosive atmosphere.



Danger!

Danger to life from electric shock

Using the wrong tool does not provide adequate insulation and can result in electric shock.

In order to adjust operating elements, only use tools that are properly insulated against the voltages applied.

These operating elements are:

DIP Switches

Via DIP switches you can configure the basic functions of the device.



Figure 3.9

- 1 DIP switch

Potentiometers

Via potentiometers you can configure the calibration of input and output characteristics.



Figure 3.10

- 1 Potentiometer

USB Connection for the Connection of a PC with Parameterization Software

Via parameterization software you can configure the device easily. The configuration data can be edited and saved. The parameterization software helps users for maintenance, diagnostics and troubleshooting.



Danger!

Danger to life from electric shock

Working on live parts at voltages higher than 50 V AC or 120 V DC can result in electric shock. Using accessories not specified by the manufacturer can compromise the function and the electrical safety of the device.

- Only use accessories specified by the manufacturer.
- Only use the approved adapter to connect the device to the computer.
- In case of voltages in excess of 50 V, ensure the device is de-energized before inserting or removing the adapter.

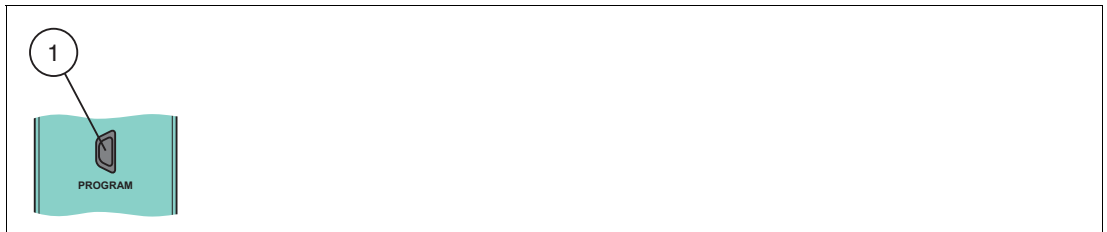

Figure 3.11

- 1 USB connection



Configuring the Device

Set the respective operating elements as described in section "Configuration" of the data sheet.



Note

See corresponding datasheets for further information.



4 Operation

4.1 Fault Monitoring

Numerous faults can occur between measurement of the process variable and evaluation in the control system. This can lead to undesirable process statuses under certain circumstances. These process statuses may result in plant downtime or quality problems or even present a hazard to persons and the environment. Depending on the device version, the isolators enable monitoring of the following faults:

- Line faults
Here, the connection cables between the isolator, the field device and the control system are monitored for lead breakages or short circuits.
- Device faults
The isolators are designed so that internal faults are detected and reported. In the case of a power failure, the outputs are switched to the de-energized state.

4.2 Fault Output

Numerous SC-System isolators monitor the field cables for lead breakages and short circuits so that faults in the plant can be detected immediately. Line faults are prevented from being interpreted as signals. Depending on the configuration of the devices, these faults are transmitted to the outputs at the control side and in separate fault indication outputs as additional information.

4.3 Current and Voltage Standard Signals

The following signals have established themselves as the standard:

- the 0/4 mA to 20 mA current signal
- the 0/2 V to 10 V voltage signal
- the 0/1 V to 5 V voltage signal

Analog sensor signals and digital frequency signals are converted into one of the two standard signals for processing in a wide variety of measurement, regulatory and control tasks. This offers the measurement and control technician an easy-to-measure standard signal common to all manufacturers. Sensor signals are converted into standard signals via signal converters.

For more diagnostic options, the NAMUR organization published NAMUR recommendation NE43, dividing the value range of the signal (e. g. current signal) into several areas. Valid, defined measurement value information is transferred within the range from 3.8 mA to 20.5 mA. Failure information is available when the signal current is < 3.6 mA or > 21 mA i. e. outside of the range for measured value information. The same applies to the voltage signal.

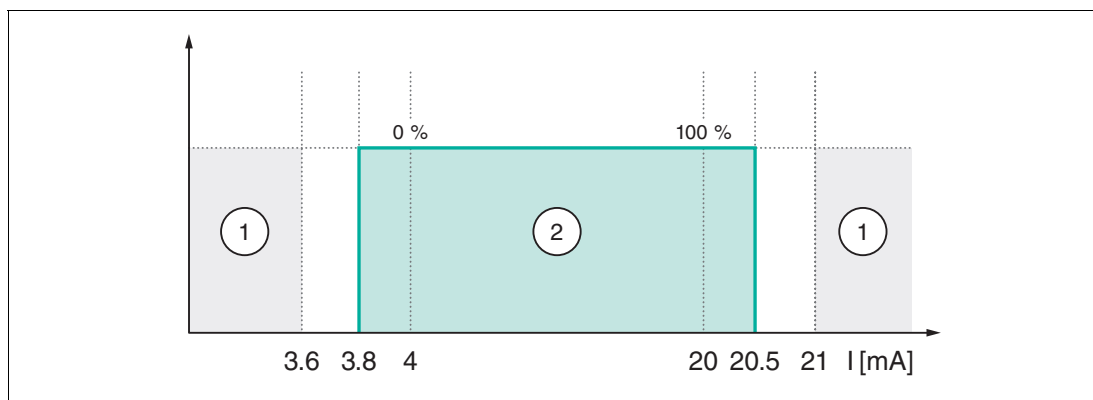

Figure 4.1 Signal ranges according to NAMUR NE43 (e. g. current signal)

- 1 Failure information
- 2 Measuring information

5 Dismounting, Maintenance, and Repair



Danger!

Explosion hazard from live wiring of circuits

If you connect or disconnect energized circuits in a potentially explosive atmosphere, sparks can ignite the surrounding atmosphere.

Only connect or disconnect energized circuits in the absence of a potentially explosive atmosphere.



Danger!

Danger to life from electric shock

Working on live parts at voltages higher than 50 V AC or 120 V DC can result in electric shock.

1. De-energize the device.
2. Secure the circuit against reconnection.
3. Verify that the device is de-energized at all poles.
4. Provide protection from adjacent live parts, if present.



Danger!

Danger to life from using damaged or repaired devices.

Using a defective or repaired device can compromise its function and its electrical safety.

- Do not use a damaged or polluted device.
- The device must not be repaired, changed or manipulated.
- If there is a defect, always replace the device with an original device from Pepperl+Fuchs.



Disconnecting Circuits

1. Disconnect the field circuit.
2. Disconnect the control circuit.
3. Disconnect the power supply.



Removing the Device

Remove the device with a tool. See figure below.

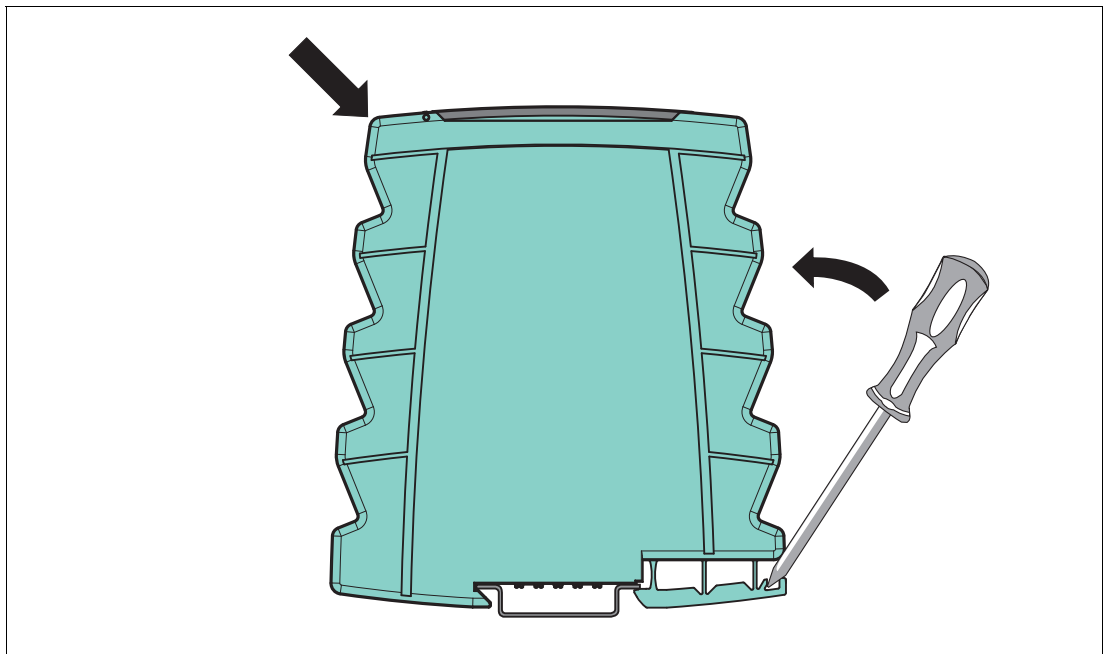

Figure 5.1

6 Technical Specifications

6.1 Technical Data

Electrical Data

Control Circuit Signals

- 0/4 mA to 20 mA signal level according to NE43
- 0/2 V to 10 V signal level according to NE43
- 0/1 V to 5 V signal level according to NE43
- Current output HART compatible
- Current input HART compatible
- Relay output 2 A, minimum load 1 mA/24 V
- Logic level 24 V according to IEC 60946

Field Circuit Signals

- Transmitter power supply up to 17 V DC
- Pt100, 2-, 3-, (4)-wire technology
- Resistor 0 Ω to 5 k Ω with freely definable characteristic
- Potentiometer
- Thermocouples of all types, internal cold junction, external reference
- Digital input for 2- or 3-wire sensors

Power Supply

- Supply voltage 24 V DC via Power Bus or supply terminals

Ambient Conditions

Ambient Temperature

- -25 °C to 70 °C (-13 °F to 158 °F), exceptions see data sheets

Storage Temperature

- -40 °C to 85 °C (-40 °F to 185 °F), exceptions see data sheets

Reference Conditions for Adjustment

- 20 °C (68 °F)

Relative Humidity

- max. 95 % without moisture condensation

Vibration Resistance

- according to EN 60068-2-6, 10 Hz to 150 Hz, 1 g, high crossover frequency

Shock Resistance

- according to EN 60068-2-27, 15 g, 11 ms, half-sine

Labeling

Place for labeling on the front side

Mechanical Specifications

Mounting

- Snap-on 35 mm DIN mounting rail according to EN 60715. Can be mounted horizontally or vertically, side by side.

Material

- Housing: polyamide (PA)
- Front cover: polycarbonate (PC)

Dimensions

- Dimension drawings please refer to chapter Dimensions.

Degree of Protection

- IP20 according to EN 60529

Connection

- Screw terminals with integrated self opening terminals for conductors with core-cross section of up to 2.5 mm² (14 AWG)
Observe the tightening torque of the terminal screws. The tightening torque is 0.5 Nm to 0.6 Nm.
- Spring terminals for conductors with core-cross section of up to 2.5 mm² (14 AWG)

Fire Protection Class

- Housing: V0 according to UL 94 standard. Unless stated otherwise all details relate to the reference conditions.



Note

See corresponding datasheets for further information.



6.2 Model Number Description

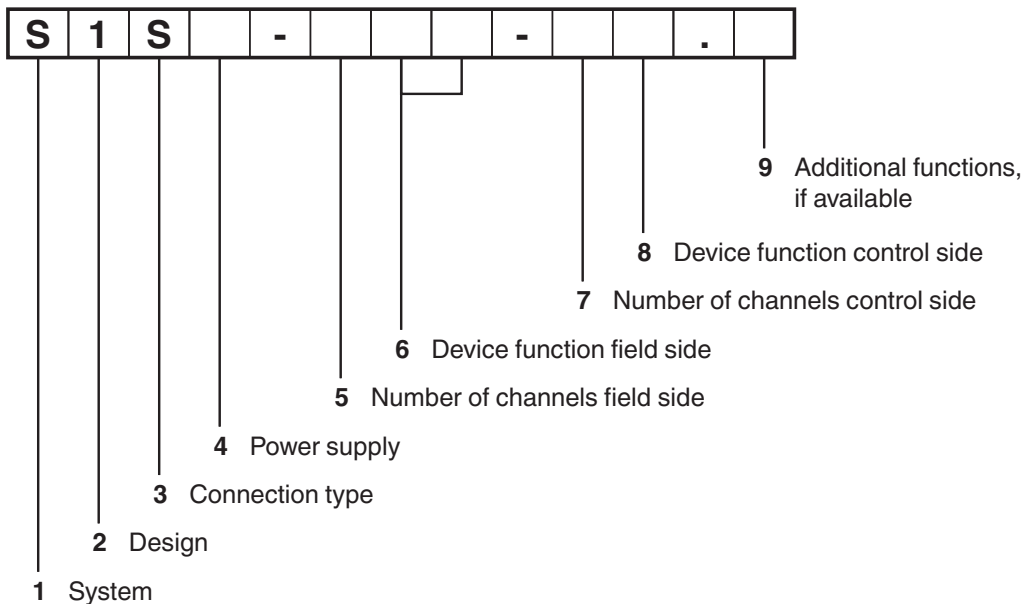

Position 1	S	SC-System
Position 2	1	Housing type 1, 6.2 mm width
Position 3	P	Spring terminal
	S	Screw terminal
Position 4	D	24 V DC
	L	Loop powered
Position 5	1	1-channel
	2	2-channel
Position 6	AI	Analog input
	DI	Digital input
	FI	Frequency converter
	PF	Power feed module
	TI	Temperature converter
Position 7	1	1-channel
	2	2-channel
Position 8	C	Current output
	R	Relay contact output
	U	Current and voltage output
Position 9	1	Isolated amplifier
	2	Isolated amplifier for bipolar signals
	3	Signal converter for millivolt signals
	H	HART communication



6.3 Dimensions

6.3.1 Housing Types Signal Conditioners SC-System

Housing type S1

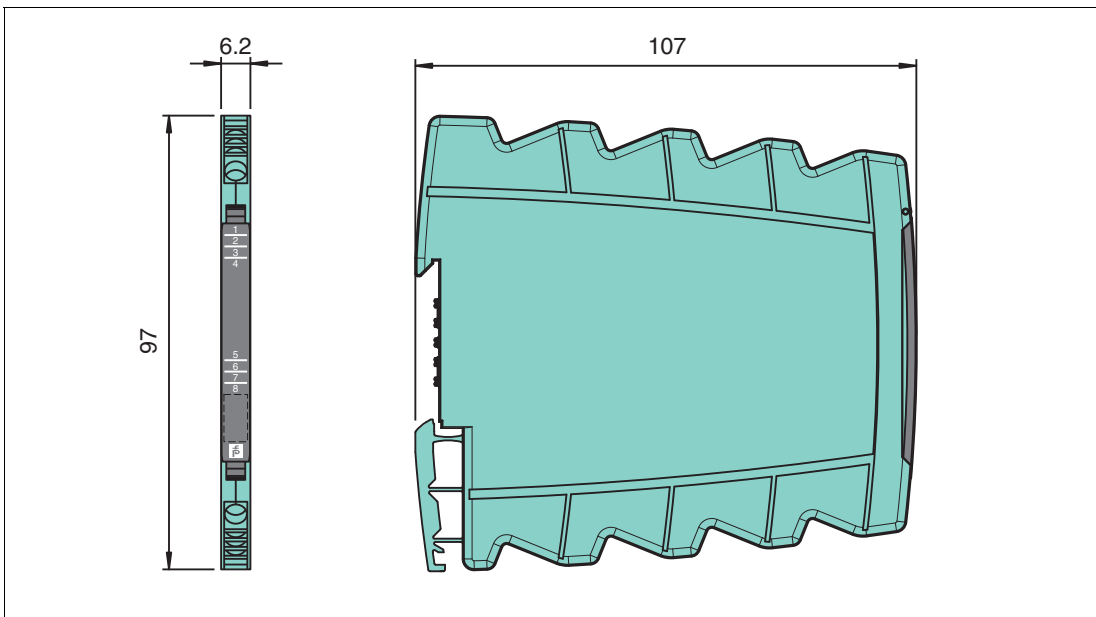

Figure 6.1





2019-10

PROCESS AUTOMATION – PROTECTING YOUR PROCESS



Worldwide Headquarters

Pepperl+Fuchs Group
68307 Mannheim · Germany
Tel. +49 621 776-0
E-mail: info@de.pepperl-fuchs.com

For the Pepperl+Fuchs representative
closest to you check www.pepperl-fuchs.com/contact

www.pepperl-fuchs.com

 **PEPPERL+FUCHS**
PROTECTING YOUR PROCESS

Subject to modifications
Copyright PEPPERL+FUCHS • Printed in Germany



**SCATTERGOOD
& JOHNSON LTD**
ELECTRICAL ENGINEERING & FLUID CONTROL DISTRIBUTORS

Est.1899

At Scattergood & Johnson Ltd, we pride ourselves on being a technical distributor to specialist industries.

Working with a range of quality product suppliers across a number of specialist markets, we are not your average 'box shifter' - we are your technical and supply chain partner.

We fully support every product we sell - for free! Our internal team and external sales engineers can answer any product or application question, no matter the complexity.

Backing up this technical ability is a range of 50,000+ products available from stock for nationwide next day delivery (same day if required!), or you can collect what you need from any of our trade counters around the UK.

Select your specialist interest below to learn more about how we can help.

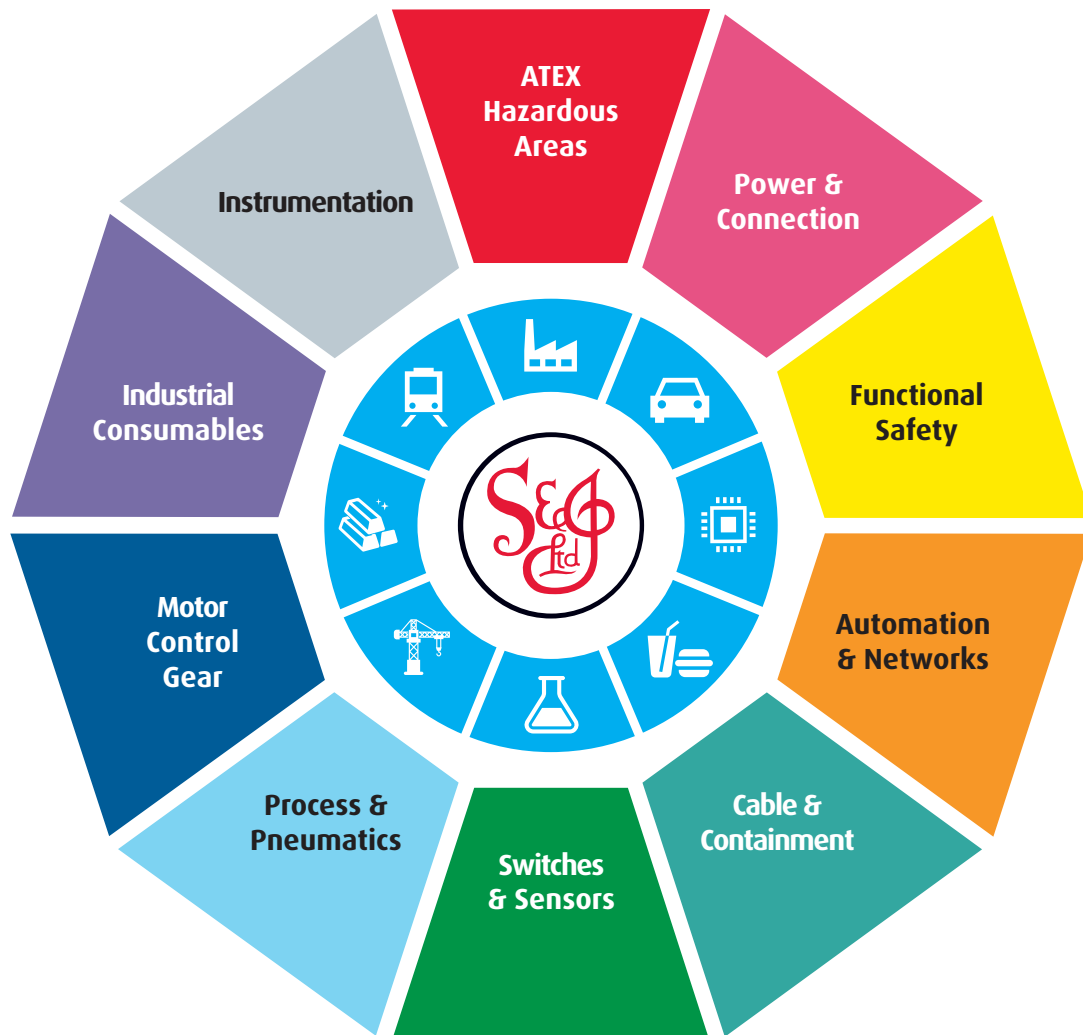

Online, In Branch and On the Road - Scattergood & Johnson Ltd, there when you need us.

www.scatts.co.uk