

MANUAL

**OVERSPEED/UNDERSPEED
MONITOR
KF**-DWB-(EX)1.D**

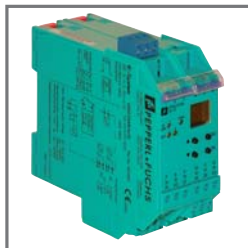

With regard to the supply of products, the current issue of the following document is applicable:
The general terms of delivery for products and services of the electrical industry, as published
by the central association of the "Elektrotechnik und Elektroindustrie (ZVEI) e.V.",
including the supplementary clause "Extended reservation of title".

1	Symbols Used	3
2	Overview	3
2.1	Range of application	3
2.2	Model variants	4
2.3	Inputs and outputs	5
3	Safety Notes	6
4	Explosion Protection	7
5	Installation and Connection	7
5.1	Installation	7
5.2	Connection	8
5.2.1	Connection input (field circuit)	9
5.2.2	Connection output	10
5.3	Indicating and operating elements of the DWB	11
6	Parameterization menu overview	12
7	Editing device data	13
7.1	Display mode	13
7.2	Main menu	14
7.3	Unit	15
7.4	Input	16
7.4.1	Input: Error	17
7.4.2	Input: Smoothing	18
7.4.3	Input: Pulses per revolution	19
7.4.4	Input: Contact bounce filter	19
7.4.5	Input: Start-up override	20
7.4.6	Activating start-up override	20

7.5	Output	21
7.5.1	Switching behavior of the relay	22
7.5.2	Output: Min/Max (switch direction)	24
7.5.3	Output: Trip point	24
7.5.4	Output: Hysteresis	25
7.5.5	Output: Mode of operating	25
7.5.6	Output: Alarm freeze (restart inhibit)	26
7.6	Service	27
7.6.1	Entering and activating password	27
7.6.2	Selecting display language	28

1 Symbols Used



Warning

This symbol warns of possible danger.

Failure to heed this warning may result in personal injury or death, or property damage, including destruction.



Attention

This symbol warns the user of a possible fault.

Failure to heed this warning can lead to total failure of the device and any other connected equipment.



Note

This symbol draws attention to important information.

2 Overview

2.1 Range of application

The K-System devices from Pepperl+Fuchs are used for transmitting signals between field devices and a process control system/control system.

The devices marked with "Ex" in the type designation are suitable for the connection of field devices used in potentially explosive atmospheres. Safe field circuits for these devices are intrinsically safe and are galvanically isolated from non-intrinsically safe circuits. The devices thus establish an electromagnetic separation between the potentially explosive atmospheres and the safe areas in a system.

Devices without Ex-identification can be used to transmit signals between field devices and the process control system/control unit.



Typical applications for the Overspeed/Underspeed Monitors KF**-DWB-(Ex)1.D of the K-System (abbreviated DWB) are limit-value monitoring during flow and rotational-speed measurements (Max alarm and Min alarm).

The Overspeed/Underspeed Monitors are parameterized using an integrated control panel.

More information (for example, certificates and data sheets for the DWB and the operating manual for the K-System) can be found on our webpage www.pepperl-fuchs.com (enter *DWB* in the product search).

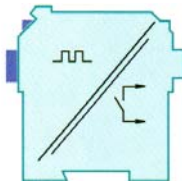

2.2 Model variants

The following variants of the Overspeed/Underspeed Monitor are available:

KF**-DWB-**1.D

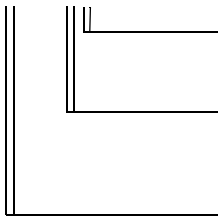

.D = with keypad

Ex = for connection of field devices in areas exposed to danger of explosion

without identifier letters = for connection of field devices in the safety area

D2 = with a power supply of 24 V DC

A5 = with a power supply of 115 V AC

A6 = with a power supply of 230 V AC

2.3 Inputs and outputs

A K-System DWB from Pepperl+Fuchs has

- an **input** for connecting a field device.
 - With KF**-DWB-Ex1.D, this input is intrinsically safe (blue terminal block). You may connect either a NAMUR sensor or a mechanical contact.
 - With KF**-DWB-1.D, the input is not intrinsically safe (green terminal block). You may connect a NAMUR sensor, a mechanical contact or a 3-conductor sensor. A DWB also has
- two **relay outputs** for limit-value display. These are for
 - Max alarm and for
 - Min alarm and
- a non-intrinsically safe input for the
 - remote activation of the start-up override and the
 - resetting of the restart inhibition (alarm freeze).

Field device input



Outputs, start-up override, power supply

3 Safety Notes



Warning

*The Overspeed/Underspeed Monitor KF**-DWB-(Ex)1.D must only be operated by trained personnel in accordance with this handbook.*



Warning

The protection of operating personnel and of the system is only ensured if the devices are used in accordance with their intended purpose. Any other type of operation than that described in this manual places the safety and functionality of the devices and systems connected to them in question.



Warning

*The devices may only be installed, connected, and adjusted by electrical professionals **outside the hazardous area.***



Warning

If faults cannot be eliminated, the devices must be taken out of operation and protected from being placed in service again inadvertently. Devices must only be repaired directly by the manufacturer Pepperl+Fuchs. Tampering with or making changes to the devices is dangerous and therefore not permitted. They render the warranty void.



Note

The responsibility for the adherence to local safety standards lies with the operator.

4 Explosion Protection

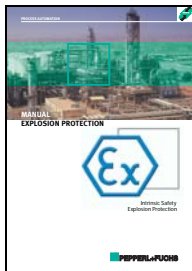

For primary explosion protection, that is, for measures to be taken to prevent or hinder the development of a dangerous explosive atmosphere, please observe the guideline 1999/92/EC (ATEX 137) or the corresponding national guidelines.

For secondary explosion protection, that is, for measures to hinder the ignition of a surrounding explosive atmosphere by electrical devices, Pepperl+Fuchs will gladly make the "Explosion Protection Manual" available to you for a nominal free.

Note in particular DIN EN 60079-10, DIN EN 60079-14, DIN EN 50014 and DIN EN 50020, or the corresponding national guidelines.

Pepperl+Fuchs also offers a seminar on the topic of explosion protection.

5 Installation and Connection

5.1 Installation



Attention

*The Overspeed/Underspeed Monitor KF**-DWB-(Ex)1.D is constructed in protection degree IP20 and must therefore be protected from undesirable ambient conditions (water, small foreign objects).*



The devices of the K-system from Pepperl+Fuchs and thus also the Overspeed/Underspeed Monitor KF**-DWB-(Ex)1.D can be mounted on a 35 mm standard rail corresponding to DIN EN 60175. The devices must be snapped onto the rail **vertically**, and never slanted or tipped to the side.

Additional possibilities for mounting, e. g. using the Power Rail, can be found in the data sheets and in the K-System operating manual on our webpage www.pepperl-fuchs.com (enter "DWB" in the product search).

Dimensions of
KF**-DWB-(Ex)1.D in mm

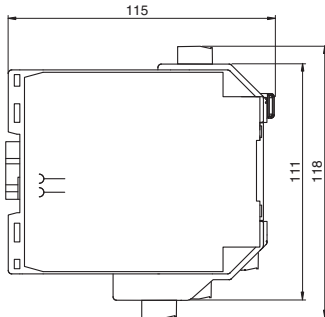

5.2 Connection

The removable terminals of the KF-series considerably simplify the connection and the switch cabinet assembly. They make it possible to replace devices quickly and without error if a customer service becomes necessary.

Terminals are equipped with screws, are self-opening, have a large connection area for a wire cross-section up to 2.5 mm² and coded plugs, making it impossible to mix them up.



5.2.1 Connection input (field circuit)

The intrinsically safe field circuit is connected at the **blue** terminals 1 ... 3 of the KF**-DWB-Ex1.D. These may be guided into the potentially explosive areas with connector cables in accordance with DIN EN 60079-14. You may connect:

- a sensor in accordance with DIN EN 60947-5-6 (NAMUR)
- a mechanical contact
- a mechanical contact with shunt resistor
- a mechanical contact with series and shunt resistors

The non-intrinsically safe field circuit is connected at the **green** terminals 1 ... 3 of the KF**-DWB-1.D. In addition to the possibilities listed above, you may also connect:

- a 3-wire sensor

Terminals 4 ... 6, 7 ... 9 and 19 ... 21 do not exist on the DWB.

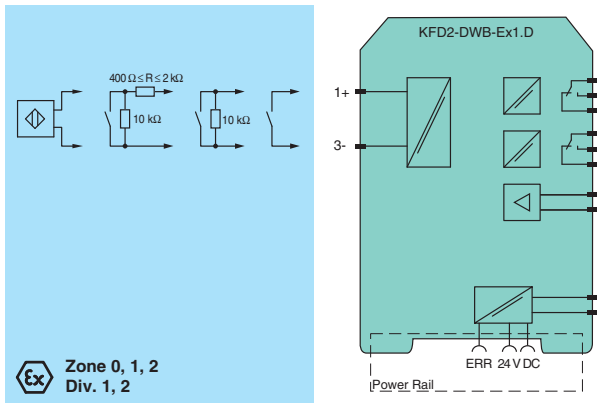

Zone 0, 1, 2
Div. 1, 2

5.2.2 Connection output

The remaining green terminals serve the following functions:

- Terminals 10 ... 12: relay 1
- Terminals 13 and 14: input start-up override (15 free)
- Terminals 16 ... 18: relay 2
- Terminals 23 and 24: power supply (22 free)

More information on connecting the DWB (e. g. using the Power Rail) can be found in the data sheets and the K-System operating manual on our webpage www.pepperl-fuchs.com (enter "DWB" in the product search).

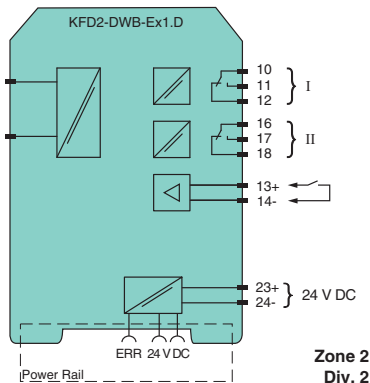

5.3 Indicating and operating elements of the DWB

Located on the front side of the DWB are:

- LED IN/CHK 1 (yellow/red) for displaying the input signal (flashes yellow in time), an input error (flashes red) and a device error (permanent red)
- LED PWR (green) for displaying the supply voltage
- LED OUT 1 (yellow) to indicate relay 1 active
- LED OUT 2 (yellow) to indicate relay 2 active
- a display for measuring-value and error indication and for parameterization mode
- four keys for setting the parameters of the DWB:
▲ (Up) ▼ (Down) ESC (Escape) OK

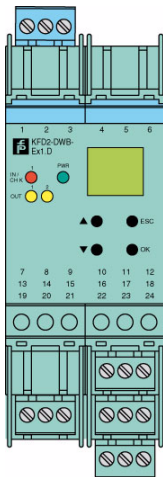

6 Parameterization menu overview

The following figure should serve as a reference for quick orientation, particularly when you are already familiar with how to parameterize the DWB. A detailed description of the operating steps can be found in chapter 7.

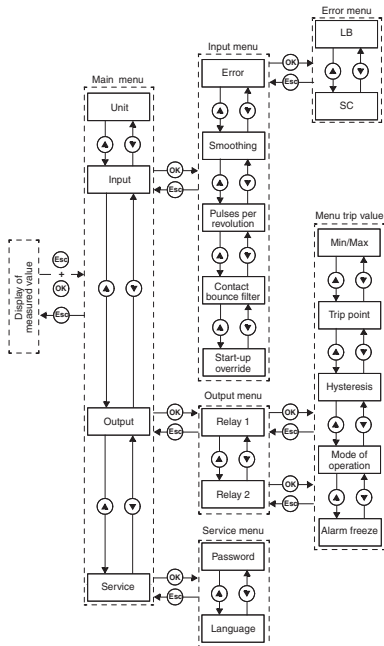

7 Editing device data

7.1 Display mode

In normal operation the current measuring value is shown on the display in the selected unit. To select the unit see chapter 7.3.

If the restart inhibit (see chapter 7.5.6) has been triggered and the device is still in normal operation, *Alarm freeze* is shown in the second line of the display in addition to the current measuring value.

In the event of an **error**, an error message is displayed (if appropriately parameterized) until corrected:

- *Err device* for a device error
- *Err SC* for a short circuit in the sensor line
- *Err LB* for an interruption in the sensor line

To select the error messages see chapter 7.4.1. The relays always switch to the de-energized state in the event of an error.

7.2 Main menu

To change to the Main menu of the parameterization mode from the display mode, simultaneously press the *Esc* and *OK* buttons for approx. 1 second.

You can prevent unauthorized persons from making changes in the parameterization mode by means of a password (see chapter 7.6.1). While it is possible in this case to view the various settings in the parameterization mode before entering a password, no changes can be made. The first time an attempt is made to change a setting, the device automatically prompts the user for a password. The password must be entered **once each time** you change from display mode to parameterization mode. The entry is described in chapter 7.6.1.

The Main menu consists of 4 menu items (Unit, Input, Output, Service). You can switch between them using the \blacktriangle and \blacktriangledown buttons. With the *Esc* button, you can return at any time from the Main menu to the display mode.

If no button is pressed for 10 minutes while in the parameterization mode, the device automatically returns to the display mode.

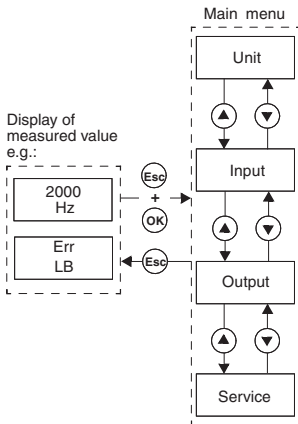

7.3 Unit

From the menu option *Unit* of the Main menu, you can use the *OK* button to access the selection for the unit of the measuring value display (Hz or rpm = rotations per minute).

How to change the setting:

- The current selection is displayed. Use the ▲ and ▼ buttons to alternate between the possible settings. If neither the ▲ nor ▼ button is pressed, the new set value flashes.
- If you press the *Esc* button, the old value is redisplayed.
- If you press the *OK* button, the displayed value is saved and then displayed without flashing.
- If the value does not flash, you can use the *Esc* button to return to the next-higher menu.

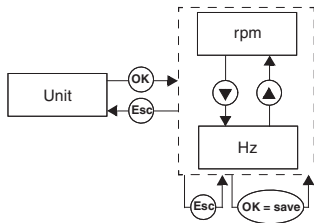

7.4 Input

From the menu option *Input* of the Main menu, you can use the *OK* button to switch to the Input menu.

This consists of 4 or 5 menu options (*Error*, *Smoothing*, *Pulses per revolution*, *Contact bounce filter* and *Start-up override*). You can switch between these options with the **▲** and **▼** buttons.

The menu option *Pulses per revolution* only appears when *rpm* has been selected as the unit for the measuring value display (see chapter 7.3).

With the *Esc* button, you can return at any time from the Input menu to the Main menu.

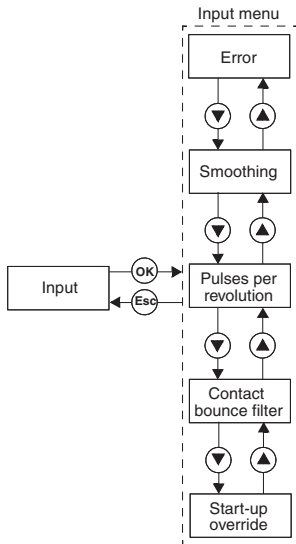

7.4.1 Input: Error

From the menu option *Error* of the Input menu, you can use the *OK* button to switch to the Error menu.

This menu consists of 2 menu options (LB = line break and SC = short circuit). You can switch between them using the ▲ and ▼ buttons.

With the *Esc* button, you can return at any time from the Error menu to the Input menu.

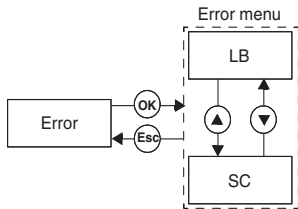

From the menu option *LB* of the Error menu, you can use the *OK* button to access the line-breakage monitoring selection (ON or OFF).

If a mechanical contact is connected as a sensor, an appropriate shunt resistor must be present for the line-breakage monitoring.

The selection of short-circuit monitoring is performed analogously.

If a mechanical contact is connected as a sensor, an appropriate series resistor must be present for the short-circuit monitoring.

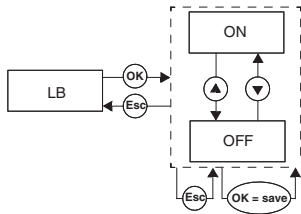

7.4.2 Input: Smoothing

From the menu option *Smoothing* of the Input menu, you can use the *OK* button to access the selection for the smoothing value.

With strongly fluctuating measuring values, you can use smoothing to influence how fast a relay reacts to a change in input value. You can set values between 0 (no smoothing) and 255 (maximum smoothing).

How to change the setting:

- The set value is displayed. This value can be changed using the ▲ and ▼ buttons. When you quickly press either the ▲ or ▼ button, the value changes incrementally. If either the ▲ or ▼ button is pressed for a longer period of time, the setting "rolls" to higher or lower values, respectively. If neither the ▲ nor ▼ button is pressed, the new set value flashes.
- If you press the *Esc* button, the old value is redisplayed.
- If you press the *OK* button, the displayed value is saved and then displayed without flashing.
- If the value does not flash, you can use the *Esc* button to return to the next-higher menu.

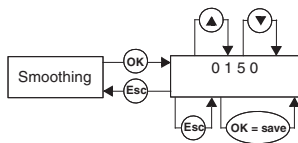

7.4.3 Input: Pulses per revolution

The menu option *Pulses per revolution* of the Input menu only appears together with the unit *rpm*. From the menu option *Pulses per revolution*, you can use the *OK* button to set the value for the pulses per revolution.

This value, which is dependent on the sensor used, is required for the output of the measuring value when the unit *rpm* is used (rotations per minute). Values between 1 and 65535 may be set for pulses/revolution.

How to change the setting is described in chapter 7.4.

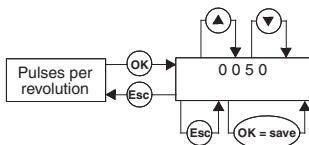

7.4.4 Input: Contact bounce filter

From the menu option *Contact bounce filter* of the Input menu, you can use the *OK* button to access the selection of the bounce filter (ON or OFF).

A bounce filter may be necessary when using a mechanical contact.

How to change the setting is described in chapter 7.4.

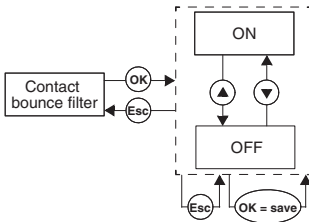

7.4.5 Input: Start-up override

From the menu option *Start-up override* of the Input menu, you can use the *OK* button to access the setting for the duration of the start-up override.

Values between 1 and 1000 seconds may be set.

How to change the setting is described in chapter 7.4.

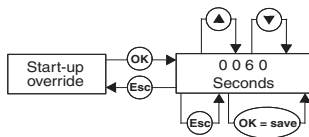

7.4.6 Activating start-up override

- If no signal at terminals 13/14 the start-up override is inactive.
- With a signal at terminals 13/14 (min. 100 ms), a relay from reporting a limit-value underrange during the override period (start-up phase).
- Start-up override only affects relays with switch direction Min. If the operating mode of such a relay is *Active*, it remains released during the override period; if the operating mode is *Passive*, it is forcibly triggered during the override period.
- The start-up override is edge triggered: before it can be retriggered, the signal at terminals 13/14 must be switched off for at least 200 ms. If a signal interruption occurs and a new signal arrives during the override period, the timer is restarted.

7.5 Output

From the menu option *Output* of the Main menu, you can use the *OK* button to switch to the Output menu.

This menu consists of 2 menu options (Rel 1 and Rel 2). You can switch between them using the ▲ and ▼ buttons.

With the *Esc* button, you can return at any time from the Output menu to the Main menu.

With the *OK* button, you can switch from both menu options of the Output menu to the Trip value menu. This is identical for both relays and is, for this reason, described here only once.

The Trip value menu consists of 5 menu options (Min/Max, Trip point, Hysteresis, Mode of operating and Alarm freeze). You can switch between them using the ▲ and ▼ buttons.

With the *Esc* button, you can return at any time from the Trip value menu to the Output menu.

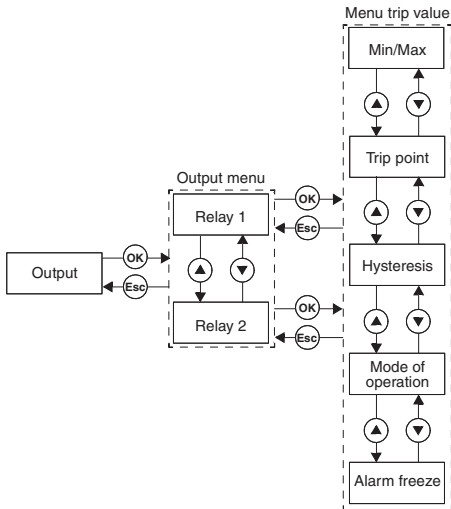

7.5.1 Switching behavior of the relay

Available settings for the switch direction are *Min* and *Max*; available settings for the operating mode (mode) are *Active* and *Passive*.

Range of application (see figure on page 23):

- Switch direction Max, operating mode active:
alarm on overrange, e. g. horn on
- Switch direction Max, operating mode passive:
overcharge protection, monitoring for excess speed, e. g. pump or drive off; with large hysteresis
Min/Max operation, e. g. pump/drive on/off
- Switch direction Min, operating mode active:
alarm on underrange, e. g. horn on
- Switch direction Min, operating mode passive:
overload protection, monitoring for underspeed, e. g. pump off, when nothing flows

Switching performance of the relay

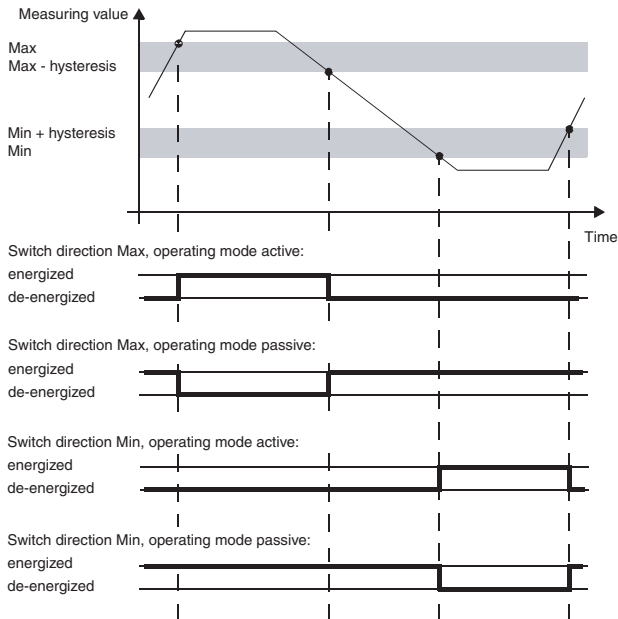

7.5.2 Output: Min/Max (switch direction)

From the menu option *Min/Max* of the Trip value menu, you can use the *OK* button to access the selection of the switch direction for the selected relay (Max or Min). How to change the setting is described in chapter 7.5.

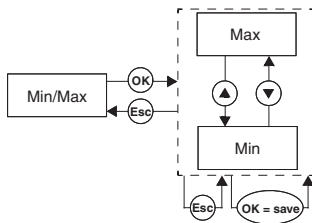

7.5.3 Output: Trip point

From the menu option *Trip point* of the Trip value menu, you can use the *OK* button to access the selection of the value for the trip point of the selected relay.

This value is to be entered in the unit which was selected under Unit (see chapter 7.3). Values between 0.001 Hz and 5000 Hz may be entered. The maximum value which may be entered for rpm is calculated from the Pulses per revolution value (see chapter 7.4.3) as $0.001 \times 60 / \text{pulses per revolution}$ and $5000 \times 60 / \text{pulses per revolution}$.

How to change the setting is described in chapter 7.4.2. The decimal point is shifted automatically.

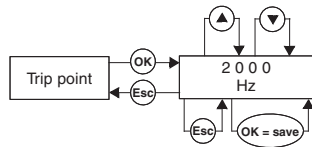

7.5.4 Output: Hysteresis

From the menu option *Hysteresis* of the Trip value menu, you can use the *OK* button to access the selection for the value of the hysteresis of the selected relay.

This value is to be entered in the unit which was selected under *Unit* (see chapter 7.3). Values between 0.001 Hz and 5000 Hz may be entered. The maximum value which may be entered for rpm is calculated from the Pluses per revolution value (see chapter 7.4.3) as $0.001 \times 60 / \text{pulses per revolution}$ and $5000 \times 60 / \text{pulses per revolution}$.

The hysteresis should be $> 1\%$ of the trip point to prevent relay chatter.

How to change the setting is described in chapter 7.4.2. The decimal point is shifted automatically.

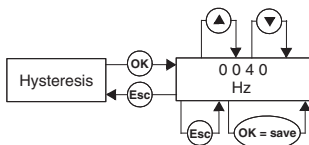

7.5.5 Output: Mode of operating

From the menu option *Mode of operating* of the Trip value menu, you can use the *OK* button to access the selection of the operating mode for the selected relay (Active or Passive).

How to change the setting is described in chapter 7.5.

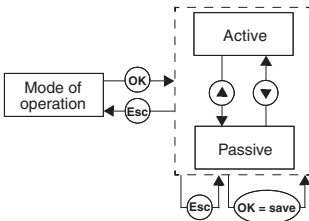

7.5.6 Output: Alarm freeze (restart inhibit)

From the menu option *Alarm freeze* of the Trip value menu, you can use the *OK* button to access the selection of the restart inhibit (ON or OFF).

The restart inhibit is used to prevent brief trip value overranges or line interference (LB, SC; see chapter 7.4.1) from not being noticed by the operating personnel.

If Alarm freeze *On* is selected, the relay remains in the new state after it is switched until one of the following actions occurs:

- Device restart
- Signal at terminals 13/14 (start-up override)
- The Esc button is pressed

Any one of these actions resets the relay.

If Alarm freeze *On* is selected and the relay is configured with the switch direction *Min*, the start-up override must be triggered on device start-up. Otherwise, the relay is immediately blocked by a trip value alarm and the restart inhibit.

How to change the setting is described in chapter 7.5.

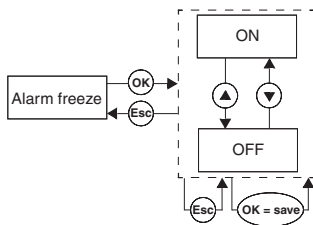

7.6 Service

You can enter the Service menu by pressing *OK* on the *Service* menu item in the main menu.

You can switch between both submenus (Password or Language) via the ▲ and ▼ buttons.

With the *Esc* button, you can return at any time from the Service menu to the main menu.

You can use the *OK* button to access the selection of the Password menu.

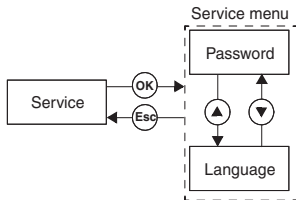

7.6.1 Entering and activating password

Activating password protection

From the menu option *Password* of the Service menu, you can use the *OK* button to access the selection of password protection.

You can switch between both menu options (ON or OFF) via the ▲ and ▼ buttons.

With the *Esc* button, you can return at any time from the Password menu to the Service menu.

You can use the *OK* button to access the activation status.

On delivery of the Overspeed/Underspeed Monitor, password protection is inactive. The password cannot be changed and is **1234**.

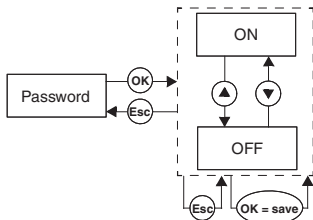

Entering password

When password protection is activated, the password must be entered **once each** time you change from the display mode to the parameterization mode. The first time an attempt is made to change a setting, the device automatically prompts the user for a password.

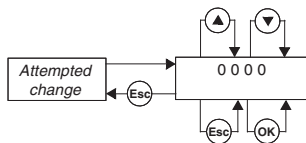

How to enter the password:

- The value 0000 is displayed. The value can be changed using the ▲ and ▼ buttons. When you press either the ▲ or ▼ button, the value changes incrementally. If either the ▲ or ▼ button is pressed for a longer period of time, the setting "rolls" to higher or lower values, respectively. If neither the ▲ nor ▼ button is pressed, the new set value flashes.
- If you press the *Esc* button, 0000 is redisplayed.
- When you press the *OK* button and the correct password has been entered, the value is displayed without flashing. If an incorrect password has been entered, 0000 is displayed again.
- Use the *Esc* button to return to the position at which you would like to change a setting.

If you have entered the correct password, you may now make your changes. If the correct password was not entered, no parameterization changes may be made.

7.6.2 Selecting display language

You can set the language value by pressing *OK* on the *Language* menu item in the Service menu. (ENG or DE).

You can switch between both menu options (ENG or DE) via the ▲ and ▼ buttons.

With the *Esc* button, you can return at any time from the *Language* menu to the Service menu.

You can use the *OK* button to access the selected language.

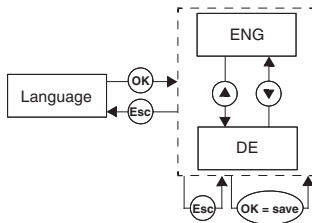

With regard to the supply of products, the current issue of the following document is applicable:
The general terms of delivery for products and services of the electrical industry, as published
by the Central Association of the "Elektrotechnik und Elektroindustrie (ZVEI) e.V.",
including the supplementary clause "Extended ownership rights".

PROCESS AUTOMATION – PROTECTING YOUR PROCESS



Worldwide Headquarters

Pepperl+Fuchs GmbH
68307 Mannheim - Germany
Tel. +49 621 776-0
E-mail: info@de.pepperl-fuchs.com

USA Headquarters

Pepperl+Fuchs Inc.
Twinsburg, Ohio 44087 - USA
Tel. +1 330 4253555
E-mail: sales@us.pepperl-fuchs.com

Asia Pacific Headquarters

Pepperl+Fuchs Pte Ltd.
Company Registration No. 199003130E
Singapore 139942
Tel. +65 67799091
E-mail: sales@sg.pepperl-fuchs.com

www.pepperl-fuchs.com

 **PEPPERL+FUCHS**
PROTECTING YOUR PROCESS

Subject to modifications
Copyright PEPPERL+FUCHS • Printed in Germany

DOCT-0106B 098533
05/2009



SCATTERGOOD & JOHNSON LTD

ELECTRICAL ENGINEERING & FLUID CONTROL DISTRIBUTORS

Est.1899

At Scattergood & Johnson Ltd, we pride ourselves on being a technical distributor to specialist industries.

Working with a range of quality product suppliers across a number of specialist markets, we are not your average 'box shifter' - we are your technical and supply chain partner.

We fully support every product we sell - for free! Our internal team and external sales engineers can answer any product or application question, no matter the complexity.

Backing up this technical ability is a range of 50,000+ products available from stock for nationwide next day delivery (same day if required!), or you can collect what you need from any of our trade counters around the UK.

Select your specialist interest below to learn more about how we can help.

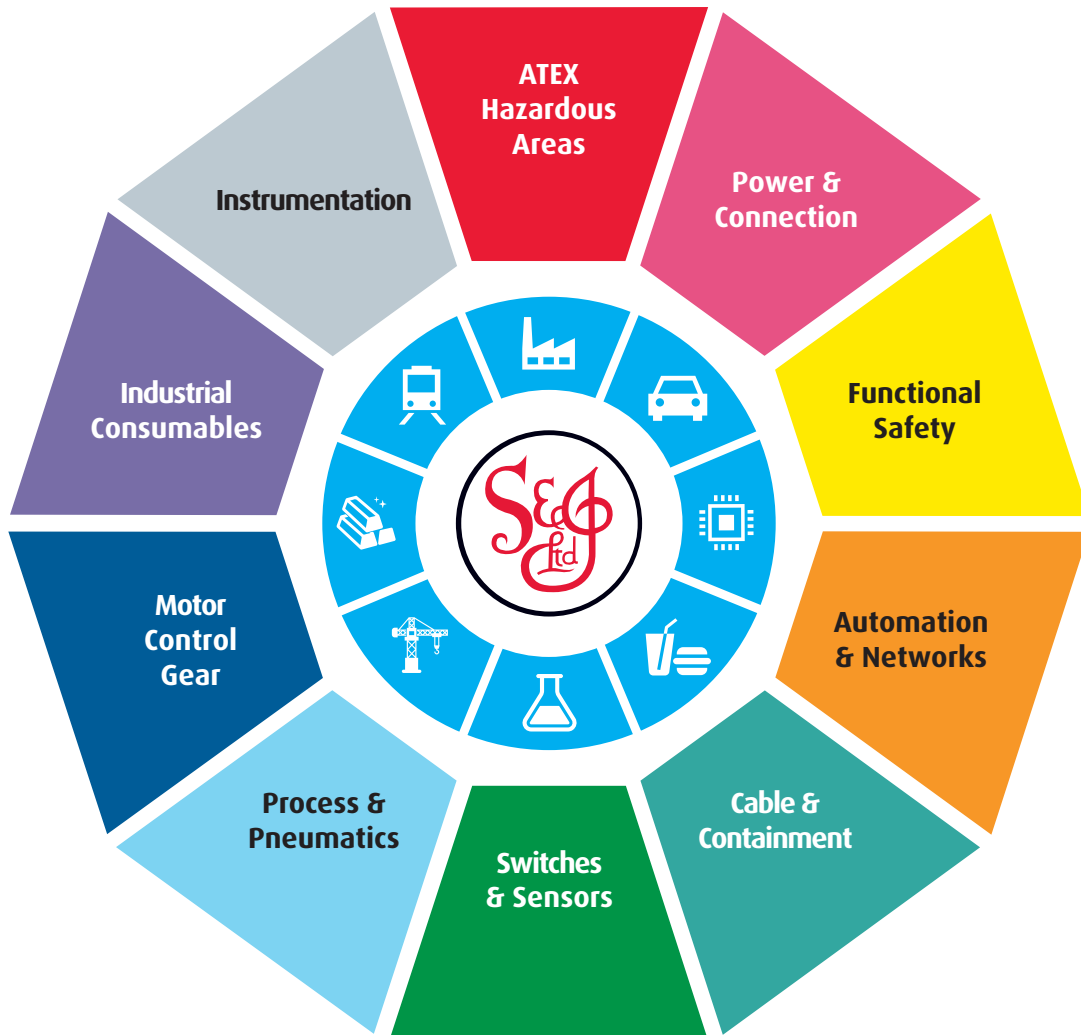

Online, In Branch and On the Road - Scattergood & Johnson Ltd, there when you need us.

www.scatts.co.uk