

Features

- 1-channel isolated barrier
- 24 V DC supply (Power Rail)
- Dry contact or NAMUR inputs
- Input frequency 1 mHz ... 5 kHz
- 2 relay contact outputs
- Start-up override
- Configurable by keypad
- Line fault detection (LFD)
- Up to SIL 2 acc. to IEC 61508/IEC 61511

Function

This isolated barrier is used for intrinsic safety applications. It monitors for an overspeed or underspeed condition of a digital signal (NAMUR sensor/mechanical contact) from a hazardous area by comparing the input frequency to the user programmed reference frequency.

An overspeed or underspeed condition is signaled via the relay outputs. Line fault detection of the field circuit is indicated by a red LED, Power Rail and relay. The start-up override feature sets relay outputs to default conditions programmed by the user for up to 1,000 seconds.

The unit is easily programmed by the use of a keypad located on the front of the unit.

A unique collective error messaging feature is available when used with the Power Rail system.

For additional information, refer to the manual and www.pepperl-fuchs.com.

Assembly

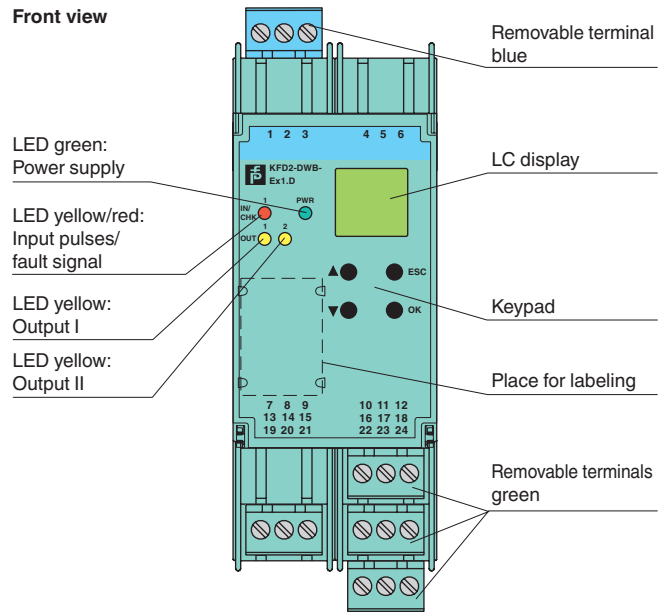

Connection

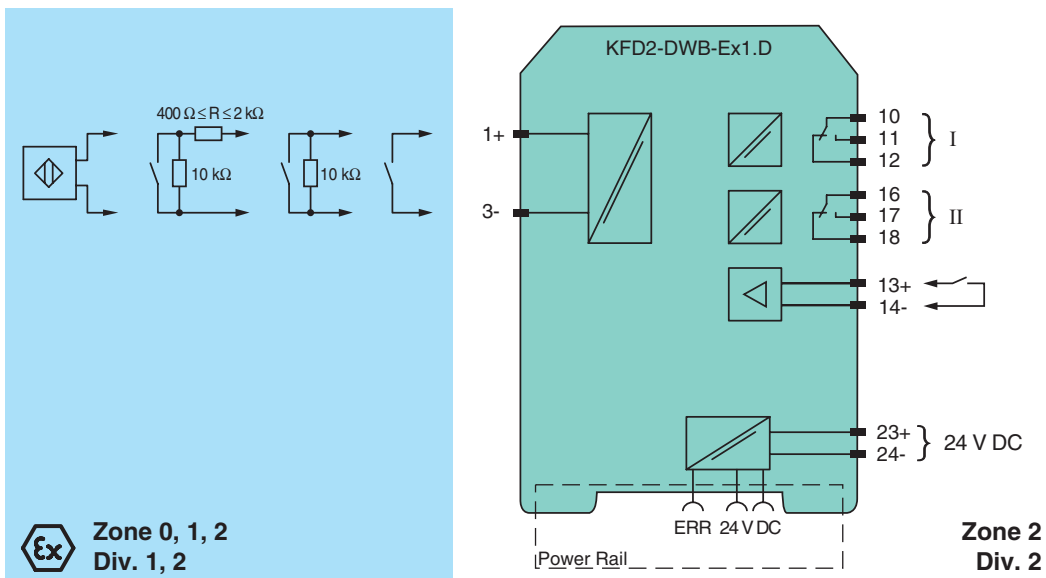

Release date 2017-09-12 15:15 Date of issue 2017-09-12 231203_eng.xml

Refer to "General Notes Relating to Pepperl+Fuchs Product Information".

General specifications	
Signal type	Digital Input
Functional safety related parameters	
Safety Integrity Level (SIL)	SIL 2
Supply	
Connection	terminals 23+, 24- or power feed module/Power Rail
Rated voltage U_r	20 ... 30 V DC
Rated current I_r	approx. 100 mA
Power dissipation/power consumption	$\leq 1.8 \text{ W} / 1.8 \text{ W}$
Input	
Connection side	field side
Connection	Input I: intrinsically safe: terminals 1+, 3- Input II: non-intrinsically safe: terminals 13+, 14-
Input I	acc. to EN 60947-5-6 (NAMUR), see system description for electrical data
Pulse duration	$> 50 \mu\text{s}$
Input frequency	0.001 ... 5000 Hz
Line fault detection	breakage $I \leq 0.15 \text{ mA}$; short-circuit $I > 6.5 \text{ mA}$
Input II	startup override: 1 ... 1000 s, adjustable in steps of 1 s
Active/Passive	$I > 4 \text{ mA}$ (for min. 100 ms) / $I < 1.5 \text{ mA}$
Open circuit voltage/short-circuit current	18 V / 5 mA
Output	
Connection side	control side
Connection	output I: terminals 10, 11, 12 output II: terminals 16, 17, 18
Output I, II	signal, relay
Contact loading	250 V AC / 2 A / $\cos \phi \geq 0.7$; 40 V DC / 2 A
Mechanical life	5×10^7 switching cycles
Energized/De-energized delay	approx. 20 ms / approx. 20 ms
Collective error message	Power Rail
Transfer characteristics	
Input I	
Measurement range	0.001 ... 5000 Hz
Resolution	0.1 % of measured value, $\geq 0.001 \text{ Hz}$
Accuracy	0.1 % of measured value, $> 0.001 \text{ Hz}$
Measuring time	$< 100 \text{ ms}$
Influence of ambient temperature	0.003 %/K (30 ppm)
Output I, II	
Response delay	$\leq 200 \text{ ms}$
Galvanic isolation	
Input I/other circuits	reinforced insulation according to IEC/EN 61010-1, rated insulation voltage 300 V _{eff}
Output I, II against each other	reinforced insulation according to IEC/EN 61010-1, rated insulation voltage 300 V _{eff}
Output I, II/other circuits	reinforced insulation according to IEC/EN 61010-1, rated insulation voltage 300 V _{eff}
Start-up override/power supply and collective error	functional insulation acc. to IEC 62103, rated insulation voltage 50 V _{eff}
Indicators/settings	
Display elements	LEDs , display
Control elements	Control panel
Configuration	via operating buttons
Labeling	space for labeling at the front
Directive conformity	
Electromagnetic compatibility	
Directive 2014/30/EU	EN 61326-1:2013 (industrial locations)
Low voltage	
Directive 2014/35/EU	EN 61010-1:2010
Conformity	
Electromagnetic compatibility	NE 21:2006
Degree of protection	IEC 60529:2001
Ambient conditions	
Ambient temperature	-20 ... 60 °C (-4 ... 140 °F)
Mechanical specifications	
Degree of protection	IP20
Connection	screw terminals
Mass	300 g
Dimensions	40 x 119 x 115 mm (1.6 x 4.7 x 4.5 inch) , housing type C3

Release date 2017-09-12 15:15 Date of issue 2017-09-12 231203_eng.xml

Mounting	on 35 mm DIN mounting rail acc. to EN 60715:2001	
Data for application in connection with hazardous areas		
EU-Type Examination Certificate	TÜV 99 ATEX 1408	
Marking	Ex II (1)G [Ex ia Ga] IIC Ex II (1)D [Ex ia Da] IIIC Ex I (M1) [Ex ia Ma] I	
Supply		
Maximum safe voltage	U_m	40 V DC (Attention! U_m is no rated voltage.)
Input I	terminals 1+, 3-: Ex ia	
Voltage	U_o	10.1 V
Current	I_o	13.5 mA
Power	P_o	34 mW (linear characteristic)
Input II	terminals 13+, 14- non-intrinsically safe	
Maximum safe voltage	U_m	40 V (Attention! The rated voltage can be lower.)
Output I, II	terminals 10, 11, 12; 16, 17, 18 non-intrinsically safe	
Maximum safe voltage	U_m	253 V (Attention! The rated voltage can be lower.)
Contact loading	253 V AC/2 A/cos $\phi > 0.7$; 40 V DC/2 A resistive load (TÜV 99 ATEX 1471)	
Certificate	TÜV 02 ATEX 1885 X	
Marking	Ex II 3G Ex nA nC IIC T4 Gc	
Output I, II		
Contact loading	50 V AC/2 A/cos $\phi > 0.7$; 40 V DC/1 A resistive load	
Galvanic isolation		
Input I/other circuits	safe electrical isolation acc. to IEC/EN 60079-11, voltage peak value 375 V	
Directive conformity		
Directive 2014/34/EU	EN 60079-0:2012+A11:2013 , EN 60079-11:2012 , EN 60079-15:2010	
International approvals		
FM approval		
Control drawing	16-538FM-12	
UL approval	E223772	
IECEX approval	IECEX TUN 03.0000	
Approved for	[Ex ia Ga] IIC, [Ex ia Da] IIIC, [Ex ia Ma] I	
General information		
Supplementary information	Observe the certificates, declarations of conformity, instruction manuals, and manuals where applicable. For information see www.pepperl-fuchs.com .	

Maximum Switching Power of Output Contacts

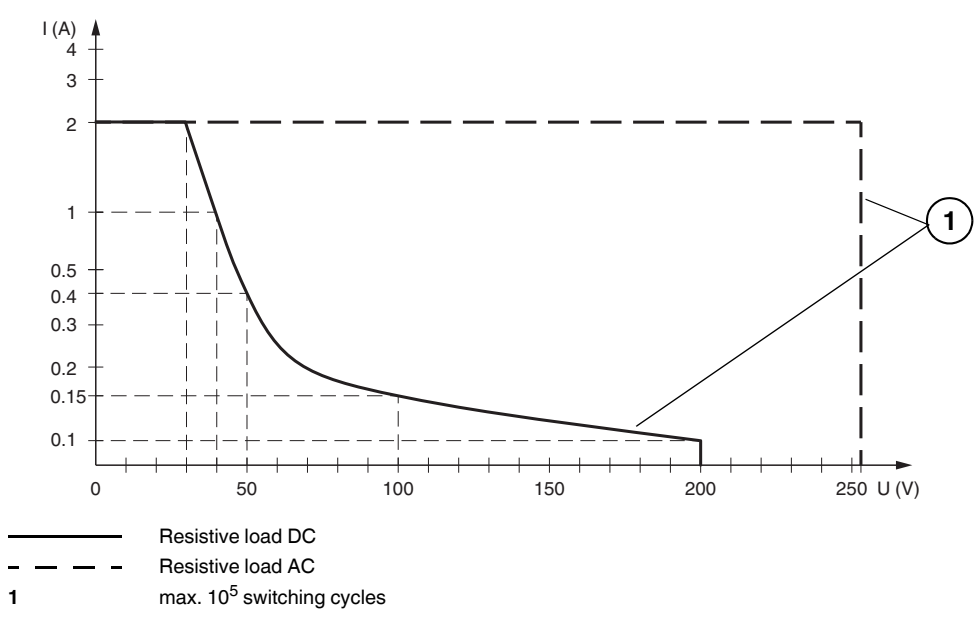

Release date 2017-09-12 15:15 Date of issue 2017-09-12 231203_eng.xml

Accessories

Power feed module KFD2-EB2

The power feed module is used to supply the devices with 24 V DC via the Power Rail. The fuse-protected power feed module can supply up to 150 individual devices depending on the power consumption of the devices. Collective error messages received from the Power Rail activate a galvanically-isolated mechanical contact.

Power Rail UPR-03

The Power Rail UPR-03 is a complete unit consisting of the electrical insert and an aluminium profile rail 35 mm x 15 mm. To make electrical contact, the devices are simply engaged.

Profile Rail K-DUCT with Power Rail

The profile rail K-DUCT is an aluminum profile rail with Power Rail insert and two integral cable ducts for system and field cables. Due to this assembly no additional cable guides are necessary.



Power Rail and Profile Rail must not be fed via the device terminals of the individual devices!



SCATTERGOOD & JOHNSON LTD

ELECTRICAL ENGINEERING & FLUID CONTROL DISTRIBUTORS

Est.1899

At Scattergood & Johnson Ltd, we pride ourselves on being a technical distributor to specialist industries.

Working with a range of quality product suppliers across a number of specialist markets, we are not your average 'box shifter' - we are your technical and supply chain partner.

We fully support every product we sell - for free! Our internal team and external sales engineers can answer any product or application question, no matter the complexity.

Backing up this technical ability is a range of 50,000+ products available from stock for nationwide next day delivery (same day if required!), or you can collect what you need from any of our trade counters around the UK.

Select your specialist interest below to learn more about how we can help.



Online, In Branch and On the Road - Scattergood & Johnson Ltd, there when you need us.

www.scatts.co.uk