

# MANUAL REMOTE PROCESS INTERFACE

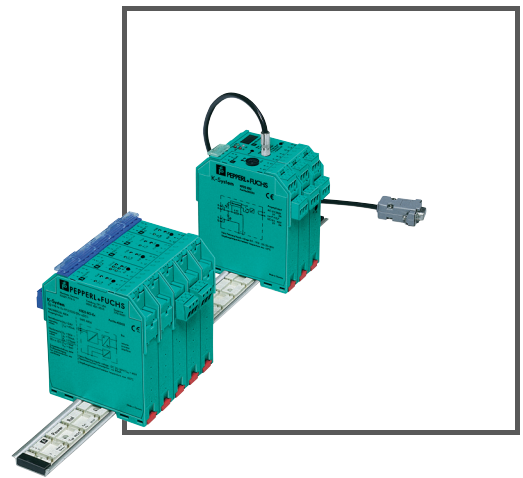

With regard to the supply of products, the current issue of the following document is applicable: The General Terms of Delivery for Products and Services of the Electrical Industry, published by the Central Association of the Electrical Industry (Zentralverband Elektrotechnik und Elektroindustrie (ZVEI) e.V.) in its most recent version as well as the supplementary clause: "Expanded reservation of proprietorship"

## INTRODUCTION, SYSTEM DESCRIPTION AND RPI SYSTEM COMPONENTS

<b>1</b>	<b>THE REMOTE PROCESS INTERFACE RPI IN BRIEF .....</b>	<b>13</b>
1.1	Availability, Functional Integrity and Function Monitoring .....	14
1.2	Aim of the Handbook .....	14
1.3	Notes on Using the Handbook .....	16
1.4	Prerequisites for RPI System Operation .....	16
1.5	Responsibilities of the User .....	17
<b>2</b>	<b>SAFETY .....</b>	<b>18</b>
2.1	Safety Notes .....	18
2.1.1	Explanation of the Symbols Used in This Document .....	18
2.1.2	General Safety Regulations .....	18
2.2	Intended Use .....	19
2.3	Installation in a Potentially Explosive Atmosphere .....	19
2.4	Installation Instructions for Use of the RPI System on Ships .....	20
2.5	Overvoltage and Lightning Protection .....	21
2.6	Declaration of Conformity .....	21
2.7	Marking .....	22
<b>3</b>	<b>PRODUCT DESCRIPTION .....</b>	<b>23</b>
3.1	System Structure and Principle of Operation .....	23
3.1.1	Modularity of the RPI System .....	23
3.1.2	Integrated Signal Transfer and Mechanical Mounting: Power Rail .....	24
3.1.3	Communication Between the RPI Modules .....	24
3.1.4	Gateways - Interface to an External Bus .....	24
3.1.5	Voltage Supply via Power Feed Modules and Power Supply Units .....	24
3.1.6	RPI Devices .....	24
3.1.7	HART Protocol Transmission .....	24
3.1.7.1	HART Programming Unit With Direct Connection .....	25
3.1.7.2	Transmission via HART Multiplexer .....	26
3.1.7.3	HART Transmission via PROFIBUS .....	27
3.2	Performance Characteristics .....	28
3.2.1	Overview of the RPI System Characteristics .....	28
3.2.2	Flexibility by Virtue of Modularity .....	29
3.2.3	Internal and external communication .....	29
3.2.4	Electrical Safety .....	29
3.2.5	System Availability .....	30
3.2.6	Configuration and Parameter Assignment .....	30
3.3	Summary of RPI Modules Currently Available .....	31
3.3.1	<b>230 V AC POWER SUPPLY UNITS .....</b>	<b>31</b>
3.3.2	<b>24 V DC POWER FEED MODULES .....</b>	<b>31</b>
3.3.3	<b>ISOLATED SWITCH AMPLIFIERS .....</b>	<b>31</b>
3.3.4	<b>SOLENOID DRIVERS AND RELAY MODULES .....</b>	<b>31</b>
3.3.5	<b>TRANSMITTER POWER SUPPLIES .....</b>	<b>31</b>

3.3.6	Analogue Driver/Repeater .....	31
3.3.7	<b>CURRENT FREQUENCY CONVERTERS, BATCH CONTROLLERS, FLOW METERS</b> .....	<b>32</b>
3.3.8	<b>TEMPERATURE CONVERTERS</b> .....	<b>32</b>
3.3.9	<b>VOLTAGE CONVERTER</b> .....	<b>32</b>
3.3.10	<b>GATEWAYS</b> .....	<b>32</b>
3.3.11	HART Modules .....	32
<b>3.4</b>	<b>Commissioning Procedure for the RPI System</b> .....	<b>33</b>
3.4.1	Configuration .....	33
3.4.2	Parameter Assignment .....	33
3.4.3	Integration into the Higher-Level Bus System .....	33
<b>3.5</b>	<b>Control Cabinets: Assembly and Service</b> .....	<b>34</b>

## PLANNING, COMMISSIONING, CONFIGURATION AND PARAMETER ASSIGNMENT

---

<b>4</b>	<b>PLANNING OF THE RPI SYSTEM</b> .....	<b>35</b>
<b>4.1</b>	<b>Planning - Basics and Procedure</b> .....	<b>35</b>
4.1.1	MSR Technology .....	36
4.1.2	Topology .....	36
4.1.3	HART Communication .....	36
4.1.4	Fieldbus and Subordinate Service Level .....	36
4.1.5	Establishing the Measuring Ranges, Basic and Miscellaneous Functions .....	36
4.1.5.1	Process Data .....	37
4.1.5.2	Device Parameters .....	37
4.1.5.3	Channel-Specific Parameters .....	37
4.1.5.4	Device and Channel-Specific Diagnostic Information .....	37
4.1.5.5	Overview of Functions and Miscellaneous Functions for Each RPI Device .....	38
4.1.6	Selecting the RPI Devices .....	39
4.1.7	Establishing the Miscellaneous and Monitoring Functions for the Operation .....	39
4.1.8	Layout and Addressing of the RPI Devices .....	40
4.1.9	Determining Where to Install the RPI System .....	40
<b>4.2</b>	<b>Planning the Transmission of HART Protocols</b> .....	<b>40</b>
4.2.1	Direct Connection of a HART Programming Unit .....	41
4.2.2	Connection to the HART Multiplexer .....	41
4.2.3	HART Transmission via KSD2-GW2-PRO Gateway .....	42
4.2.3.1	Service Interface .....	42
4.2.3.2	PROFIBUS .....	42
<b>4.3</b>	<b>General Information on Communication and Diagnostic Procedures via the Internal RPI Bus</b> .....	<b>43</b>
<b>4.4</b>	<b>Calculating the RPI Cycle Time</b> .....	<b>44</b>
<b>4.5</b>	<b>Planning the Internal and External Communication</b> .....	<b>44</b>
4.5.1	General Notes on Operating the Gateways .....	44
4.5.2	Redundancy Considerations .....	45
4.5.2.1	Redundancy Internal Bus .....	45
4.5.2.2	Gateway Redundancy .....	45
4.5.2.3	Redundancy External Bus .....	46
4.5.3	Determining the Number of RPI Gateways Required .....	46

<b>4.6</b>	<b>Establishing the Service Functionality for the RPI System</b>	<b>46</b>
4.6.1	Service Interface RS232	46
4.6.2	Service Interface RS485	46
4.6.3	PROFIBUS	46
4.6.3.1	PROFIBUS DP	46
4.6.3.2	PROFIBUS DP V1	46
<b>4.7</b>	<b>Power Supply</b>	<b>46</b>
4.7.1	Construction of the Power Feed Module	47
4.7.2	Group Fusing on the Power Feed Module	47
4.7.3	Segmentation of the RPI System	48
4.7.4	Power Feed Modules for Redundant Power Supply	48
4.7.5	Setting up the Power Supply Balance for the RPI Devices Including the Gateways	48
4.7.6	Determining the Power Supply Segments	49
4.7.7	Establishing the Type and Number of the Power Supply Modules	49
4.7.8	Establishing the Type and Number of Power Supply Units, where Required	50
<b>4.8</b>	<b>Accessories</b>	<b>50</b>
4.8.1	Power Rail	50
4.8.1.1	Power Rail UPR-05	50
4.8.1.2	Mounting the UPR-05 Power Rail	51
4.8.1.3	Accessories for Power Rail UPR-05	51
4.8.1.4	<b>POWER RAIL PR-05</b>	<b>52</b>
4.8.1.5	Mounting the <b>POWER RAIL PR-05</b>	<b>52</b>
4.8.1.6	Accessories for <b>POWER RAIL PR-05</b>	<b>53</b>
4.8.1.7	Combining the RPI System with Interface Modules from other Systems	53
4.8.2	KF Profile with Integrated Cable Ducts	54
4.8.3	Human Machine Interface PACTware™ Edition 2	55
4.8.4	Interface adapter for RS 232 and RS 485	58
4.8.5	Accessories for RPI Devices	58
<b>4.9</b>	<b>Determining the Types and Numbers of Power Rails to be Used</b>	<b>60</b>
<b>4.10</b>	<b>Arrangement of the Power Rail Segments in a Control Cabinet</b>	<b>61</b>
<b>4.11</b>	<b>Installation</b>	<b>62</b>
4.11.1	General Information on Device Connection	62
4.11.2	EMC, Screening and Earthing	62
4.11.3	Preparing the Wiring	63
4.11.4	Installing the Devices	63
4.11.5	Connection to the Control System	64
4.11.6	Connecting the Power Cables and Signal Cables	64
<b>5</b>	<b>CONFIGURING AND COMMISSIONING THE RPI SYSTEM</b>	<b>66</b>
<b>5.1</b>	<b>Offline Commissioning</b>	<b>66</b>
<b>5.2</b>	<b>Power Supply</b>	<b>67</b>
5.2.1	Construction of the Power Feed Module	67
5.2.2	Setting the Mode of Operation of the Relay	67
<b>5.3</b>	<b>RPI Devices</b>	<b>69</b>
5.3.1	Construction of the RPI Devices	69
5.3.2	LEDs on the Front Panel of a Device	69
<b>5.4</b>	<b>Configuration</b>	<b>71</b>

5.4.1	Construction of the Gateways and LEDs on the Front Panel .....	72
5.4.2	Operating the Gateways Type KSD2-GW-... .....	75
5.4.2.1	<b>ALLOCATION OF THE DEVICE ADDRESSES ON THE INTERNAL BUS .....</b>	<b>76</b>
5.4.2.2	<b>CHECKING THE DEVICE ADDRESSES ON THE INTERNAL BUS .....</b>	<b>76</b>
5.4.2.3	<b>SETTING THE GATEWAY ADDRESS ON THE EXTERNAL BUS .....</b>	<b>76</b>
5.4.2.4	<b>SETTING THE ADDRESS OF THE RS 232/RS 485 SERVICE INTERFACE .....</b>	<b>76</b>
5.4.2.5	Transfer Rate of the Internal Bus .....	76
5.4.2.6	<b>SETTING THE TRANSFER RATE OF THE RS232/RS 485 SERVICE INTERFACE .....</b>	<b>77</b>
5.4.2.7	<b>SETTING THE TRANSFER RATE OF THE EXTERNAL MODBUS .....</b>	<b>77</b>
5.4.2.8	Setting the MODBUS Parameters .....	78
5.4.2.9	Teaching-in Existing Configurations of the RPI Devices .....	78
5.4.2.10	Error Messages in the LC-Displays of the Gateways .....	79
5.4.3	Operating the Gateways of Type KSD2-GW2-... .....	80
5.4.3.1	Normal Operation: 'Run' Menu .....	80
5.4.3.2	HART Communication: 'HART' Menu .....	81
5.4.3.3	Fault .....	82
5.4.3.4	Indication of Measured Values: 'Monitor' Menu .....	82
5.4.3.5	<b>CHECKING THE DEVICE ADDRESSES ON THE INTERNAL BUS .....</b>	<b>83</b>
5.4.3.6	Error Messages .....	84
5.4.3.7	Input of Configuration Data: 'Service' Menu .....	84
5.4.3.8	General Information on Input of Parameters and Values .....	85
5.4.3.9	Teaching-In the RPI Configuration: 'Teach-In' Service Menu .....	86
5.4.3.10	Assignment of Device Addresses: 'AdrAssign' Service Menu .....	86
5.4.3.11	Activation of the Redundancy: 'RedMode' Service Menu .....	87
5.4.3.12	<b>SETTING THE ADDRESS OF THE RS 232/RS 485 SERVICE INTERFACE: 'PARADR' SERVICE MENU .....</b>	<b>87</b>
5.4.3.13	<b>SETTING THE TRANSFER RATE FOR THE RS 232/RS 485 SERVICE INTERFACE: 'PARBAUD' SERVICE MENU .....</b>	<b>87</b>
5.4.3.14	<b>SETTING THE GATEWAY ADDRESS ON THE EXTERNAL BUS: 'HstADR' SERVICE MENU .....</b>	<b>88</b>
5.4.3.15	<b>SETTING THE HART TRANSMISSION: 'HART' SERVICE MENU .....</b>	<b>88</b>
5.4.3.16	Resetting Internal Communication, 'ResIntCom' Service Menu .....	88
5.4.3.17	Switching Back from Redundant Operation: 'SetActiveMode' Service Menu .....	88
5.4.3.18	Information on Hardware and Software Versions: 'Info' Service Menu .....	88
<b>5.5</b>	<b>Verification of Device Addresses .....</b>	<b>89</b>
5.5.1	Checking the Device Address on the RPI Internal Bus .....	89
5.5.1.1	<b>CHECKING BY MEANS OF KSD2-GW-... GATEWAY .....</b>	<b>89</b>
5.5.1.2	Checking by Means of KSD2-GW2-... Gateway .....	89
5.5.2	Assignment of the Device Address for the Internal Bus .....	89
5.5.2.1	<b>ADDRESS ASSIGNMENT BY MEANS OF KSD2-GW-... GATEWAY .....</b>	<b>89</b>
5.5.2.2	<b>ADDRESS ASSIGNMENT BY MEANS OF KSD2-GW2-... GATEWAY .....</b>	<b>89</b>
5.5.3	Assignment of the Neutral Device Address 0 for the Internal Bus .....	90
<b>5.6</b>	<b>Configuration of RPI Devices with Automatic Address Assignment Using PACTware™ .....</b>	<b>91</b>
5.6.1	Configuration via the Service Interface .....	91
5.6.2	Acceptance of the Configuration and Parameter Assignment of an Existing RPI System .....	91
5.6.2.1	Gateway Type KSD2-GW-... .....	91
5.6.2.2	Gateway Type KSD2-GW2-... .....	91
5.6.3	Checking the Configuration and Parameter Assignment .....	92
<b>5.7</b>	<b>Online Commissioning .....</b>	<b>92</b>
5.7.1	Fully Mounted RPI system .....	92
5.7.2	Successive Assembly of the RPI Devices .....	92
<b>5.8</b>	<b>Configuration and Parameter Assignment via PROFIBUS DP V1 .....</b>	<b>92</b>
<b>5.9</b>	<b>Configuration and Parameter Assignment via PROFIBUS DP and GSD 0818p.gsd .....</b>	<b>92</b>

<b>6</b>	<b>PARAMETER ASSIGNMENT .....</b>	<b>93</b>
<b>6.1</b>	<b>Parameters of the RPI Modules .....</b>	<b>93</b>
6.1.1	The PACTware™ Parameterization Window .....	93
6.1.1.1	'Parameter' Tab .....	93
6.1.1.2	'Properties' Tab .....	93
<b>6.2</b>	<b>Editing a Project .....</b>	<b>94</b>
6.2.1	Opening a Project .....	95
6.2.2	New Project .....	95
6.2.3	Adding Components .....	95
6.2.4	Deleting Components .....	96
<b>6.3</b>	<b>Parameterizing Individual Components .....</b>	<b>97</b>
6.3.1	Parameters of the COM Drivers .....	97
6.3.1.1	RPI Serial Interface .....	97
6.3.1.2	HART Protocol Driver .....	97
6.3.1.3	Device Type Managers for Non-RPI Devices .....	98
6.3.2	Gateway Parameters .....	98
6.3.2.1	MODBUS RTU .....	98
6.3.2.2	MODBUS Plus .....	98
6.3.2.3	PROFIBUS DP and DP V1 .....	99
6.3.2.4	ControlNet .....	99
6.3.3	Isolated Switch Amplifier .....	100
6.3.4	Current Frequency Converter, Batch Controller .....	101
6.3.5	Solenoid Drivers .....	102
6.3.6	Relay Modules .....	103
6.3.7	Transmitter Power Supplies .....	103
6.3.8	Temperature Converter .....	105
6.3.9	Converter for Voltage .....	106
6.3.10	Analogue Driver/Repeater .....	107
<b>6.4</b>	<b>Downloading Project Data into the Gateway .....</b>	<b>108</b>
<b>6.5</b>	<b>Commissioning the Gateways and the External Bus System .....</b>	<b>108</b>
<b>7</b>	<b>INTEGRATION INTO THE HIGHER-LEVEL BUS SYSTEM .....</b>	<b>109</b>
<b>7.1</b>	<b>General Notes on Operating the Gateways .....</b>	<b>109</b>
7.1.1	Gateways of Type KSD2-GW-... .....	109
7.1.2	Gateways of Type KSD2-GW2-... .....	110
7.1.3	Data Formats .....	111
7.1.4	Status Information of Process Data .....	112
7.1.5	Operation with a Redundant Gateway .....	112
7.1.6	Exchanging a Gateway .....	113
7.1.7	Exchanging a Gateway - External Bus Redundant .....	113
<b>7.2</b>	<b>Gateways for PROFIBUS DP .....</b>	<b>114</b>
7.2.1	Gateways KSD2-GW-PRO and KSD2-GW-PRO.485 .....	114
7.2.2	Gateway KSD-GW2-PRO .....	115
7.2.3	General Notes on PROFIBUS DP .....	115
7.2.4	<b>FEATURES OF THE PROFIBUS GATEWAYS .....</b>	<b>116</b>
7.2.5	Device Connection .....	116
7.2.5.1	Gateways of Type KSD2-GW-PRO and KSD2-GW-PRO.485 .....	116

Date of issue 06/03/03

7.2.5.2	KSD2-GW2-PRO Gateway .....	116
7.2.5.3	Wiring .....	116
7.2.6	<b>PROFIBUS TRANSMISSION RATE .....</b>	<b>116</b>
7.2.7	Screening and EMC .....	117
7.2.8	GSD Files .....	117
7.2.9	Configuration of the Cyclic Communication .....	119
7.2.9.1	Representation of the Gateway in the DP Master System .....	119
7.2.9.1	Representation of the RPI modules in the Gateway .....	120
7.2.9.2	Data Structure on the PROFIBUS .....	121
7.2.9.3	Format of the Input and Output Data .....	122
7.2.9.4	Structure of the Status Information .....	125
7.2.10	Commissioning .....	127
7.2.11	<b>GATEWAY-SPECIFIC DIAGNOSTIC INFORMATION .....</b>	<b>128</b>
<b>7.3</b>	<b>KSD2-GW-MOD and KSD2-GW-MOD.485, Gateways for the Modbus RTU .....</b>	<b>135</b>
7.3.1	Device Connection .....	136
7.3.2	Commissioning .....	137
7.3.3	Operation with a Redundant Gateway .....	137
7.3.4	Operation on the Modbus .....	138
7.3.5	Reading Binary Input Data without Status .....	139
7.3.6	Reading binary input data with status .....	142
7.3.7	Writing/Reading Binary Output Data without Status .....	143
7.3.8	Writing/Reading Binary Output Data with Status .....	146
7.3.9	Reading Analogue Input Data without Status .....	147
7.3.10	Reading Analogue Input Data with Status .....	149
7.3.11	Writing/Reading Analogue Output Data without Status .....	151
7.3.12	Writing/Reading Analogue Output Data with Status .....	153
7.3.13	Special case: Holding Register .....	155
7.3.14	Configuring an RPI System via the Host .....	159
7.3.15	Diagnosis .....	160
7.3.16	Summary of Tables .....	162
<b>7.4</b>	<b>Gateways for the MODBUS Plus .....</b>	<b>164</b>
7.4.1	Gateways KSD2-GW-MPL and KSD2-GW-MPL.485 .....	164
7.4.2	Device Connection .....	164
7.4.3	Modbus Plus address .....	166
7.4.4	Commissioning .....	166
7.4.5	Data Transfer on the Modbus Plus .....	166
7.4.6	Structure of Control Register Areas .....	167
<b>7.5</b>	<b>Gateways for ControlNet .....</b>	<b>169</b>
7.5.1	KSD2-GW-CN and KSD2-GW-CN.485 Gateways .....	169
7.5.2	Device connection .....	169
7.5.3	ControlNet Address .....	171
7.5.4	Commissioning .....	171
7.5.5	Operation on the ControlNet .....	171
7.5.6	Data Transmission .....	171
7.5.7	Command/Response Transmission .....	173

## MONITORING, SIMULATING MEASURED VALUES AND ERROR HANDLING

<b>8</b>	<b>RPI IN OPERATION</b>	<b>174</b>
<b>8.1</b>	<b>Displaying Measured Values</b>	<b>174</b>
<b>8.2</b>	<b>Displaying Trends</b>	<b>175</b>
<b>8.3</b>	<b>Simulation</b>	<b>176</b>
8.3.1	Simulation of Input Signals	176
8.3.2	Simulation of Output Signals	176
<b>8.4</b>	<b>Servicing and Diagnostic System</b>	<b>178</b>
8.4.1	Via LEDs, LCD and Pushbuttons on the Devices	178
8.4.2	Via PC and PACTware™ or RPI Human Machine Interface	178
8.4.3	Via a Permanently Installed PC Based Service Level	178
8.4.4	From the Control System Engineering Console	178
<b>8.5</b>	<b>Error Handling</b>	<b>178</b>
8.5.1	Error Detection within the RPI System	178
8.5.1.1	Error Detection Using the LEDs on the Devices:	178
8.5.1.2	Error Detection Using the LC Display on the Gateway	178
8.5.1.3	Error Detection Using the PACTware™ Human Machine Interface	179
8.5.2	Error detection from the control system engineering console	179
8.5.3	Fault elimination within the RPI System	179
8.5.3.1	Replacement in the case of failure of an individual device	179
8.5.3.2	Replacement in the event of the simultaneous failure of a number of devices	179
<b>8.6</b>	<b>Error detection on the external bus system</b>	<b>180</b>
<b>8.7</b>	<b>Fault elimination on the external bus system</b>	<b>180</b>
<b>8.8</b>	<b>Replacement of Defective Gateways</b>	<b>180</b>
<b>9</b>	<b>DISMANTLING AND DISPOSAL</b>	<b>181</b>

## APPENDIX

<b>10</b>	<b>QUICK INSTRUCTIONS</b>	<b>182</b>
<b>10.1</b>	<b>Installation of the Software on your PC</b>	<b>182</b>
<b>10.2</b>	<b>Voltage supply for the RPI system</b>	<b>182</b>
<b>10.3</b>	<b>Configuration and Parameter Assignment of the RPI System</b>	<b>182</b>
10.3.1	Offline Configuration and Downloading to the Devices	182
10.3.2	Manual Address Assignment for the Devices and Subsequent Online Configuration and Parameter Assignment Using PACTware™ Edition 2 186	
<b>10.4</b>	<b>Error Messages</b>	<b>189</b>
<b>10.5</b>	<b>To Replace a Device while the System is in Operation</b>	<b>190</b>
<b>10.6</b>	<b>Replacing a Gateway</b>	<b>190</b>
<b>10.7</b>	<b>Setting Address '0' / Deleting Address on a Device</b>	<b>190</b>
<b>10.8</b>	<b>Deleting an Existing Gateway Configuration (from Version 1.4)</b>	<b>190</b>
<b>10.9</b>	<b>Redundant Power Supply</b>	<b>190</b>

<b>10.10</b>	<b>Redundant Internal Bus System .....</b>	<b>190</b>
<b>10.11</b>	<b>Redundant External Bus System .....</b>	<b>190</b>
<b>10.12</b>	<b>Construction of a Redundant External Bus System with Gateways .....</b>	<b>191</b>
<b>11</b>	<b>RPI SYSTEM ERROR MESSAGES .....</b>	<b>192</b>
<b>11.1</b>	<b>Error Messages on the Display of the KSD2-GW-.. Gateway .....</b>	<b>192</b>
<b>11.2</b>	<b>Error Messages on the Display of the KSD2-GW2-... Gateway .....</b>	<b>192</b>
<b>11.3</b>	<b>Error Messages on the Gateways via LED .....</b>	<b>193</b>
<b>11.4</b>	<b>Error Messages on the RPI Devices via LED .....</b>	<b>196</b>

## **K-SK1 - THE MAN/MACHINE INTERFACE FOR THE CONFIGURATION, PARAMETERISING, SIMULATING TESTING AND MONITORING THE RPI**

---

<b>12</b>	<b>K-SK1 .....</b>	<b>198</b>
<b>12.1</b>	<b>General .....</b>	<b>198</b>
12.1.1	Computer related font .....	198
12.1.2	Hardware requirements .....	198
12.1.3	Operating system .....	198
12.1.3.1	Installation process .....	198
<b>12.2</b>	<b>Using the Software .....</b>	<b>198</b>
12.2.1	The advantage of using software .....	198
12.2.2	Setting up a complete system .....	198
12.2.3	Monitoring and Diagnosis .....	198
12.2.4	Changing system information .....	198
<b>12.3</b>	<b>K-SK1 Operation manual .....</b>	<b>198</b>
12.3.1	Starting the software .....	198
12.3.2	The main screen .....	199
12.3.2.1	The project manager .....	199
12.3.2.2	The menu bar .....	199
12.3.2.3	The short cut buttons .....	200
12.3.2.4	The title bar .....	200
12.3.2.5	Selecting an item .....	200
12.3.2.6	The structure level buttons .....	200
12.3.2.7	The "Show details" check box .....	200
12.3.3	Handling the project .....	201
12.3.3.1	Overview .....	201
12.3.3.2	Creating a new project .....	201
12.3.3.3	Opening an existing project .....	202
12.3.3.4	Saving a project .....	202
12.3.4	Editing a project .....	202
12.3.4.1	The three parts of the edit window .....	202
12.3.4.2	Selecting the active part of the window .....	203
12.3.4.3	Getting help .....	203
12.3.4.4	Undoing changes .....	203
12.3.4.5	Adding a device .....	203
12.3.4.6	Configuring a device .....	205

12.3.4.7	Removing a device .....	206
12.3.4.8	Printing a project .....	206
12.3.4.9	Exiting the edit window .....	206
12.3.5	Connecting your PC with the RPI hardware .....	207
12.3.5.1	Connection .....	207
12.3.5.2	Setting the serial port .....	207
12.3.5.3	Starting the communication between K-SK1 and RPI .....	207
12.3.5.4	Closing down the communication between K-SK 1 and RPI .....	208
12.3.6	Editing Device Data .....	208
12.3.6.1	<b>SELECTING THE DEVICE</b> .....	<b>208</b>
12.3.6.2	Changing data .....	208
12.3.6.3	Changing between the tab strips .....	209
12.3.6.4	Setting a password .....	210
12.3.6.5	Saving data .....	210
12.3.7	Downloading a project into a gateway .....	210
12.3.8	Printing a project .....	210
12.3.9	Monitoring devices .....	210
12.3.9.1	Ending the monitoring .....	211
12.3.10	Diagnosis of devices .....	212
12.3.10.1	Ending the diagnostics .....	212
12.3.10.2	Simulating devices .....	212
12.3.10.3	Process Value .....	213
12.3.10.4	Device specific diagnostic .....	213
12.3.10.5	Channel specific diagnostic .....	213
12.3.11	Other program options .....	214
12.3.11.1	Setting basic program options .....	214
12.3.11.2	Getting help .....	214
12.3.11.3	Finding out the version of your software .....	215
12.3.12	Exiting the K-SK1 software .....	215
<b>13</b>	<b>GLOSSARY</b> .....	<b>216</b>



## INTRODUCTION, SYSTEM DESCRIPTION AND RPI SYSTEM COMPONENTS

### 1 The Remote Process Interface RPI in Brief

The Pepperl + Fuchs Remote Process Interface (RPI) is an interface system, which connects the signal currents of conventionally wired sensors, actuators and field devices on the plant side via a field bus with a process control system (DCS) or with a programmable logic controller (PLC) on the control side. An RPI system consists of modular interface modules, where the field devices are directly connected, as well as of at least one gateway functioning as communication interface between the RPI internal bus and the standard bus for plant control. PROFIBUS DP, PROFIBUS DP V1, Modbus RTU, Modbus Plus or ControlNet can be used as standard bus. The advantage of this system lies in the fact that the expensive point-to-point wiring between interface level and plant control is eliminated. The I/O level of the DCS or PLC is likewise eliminated.

By means of RPI a plant can be grouped into logical functional units. Thus a clear structuring is possible.

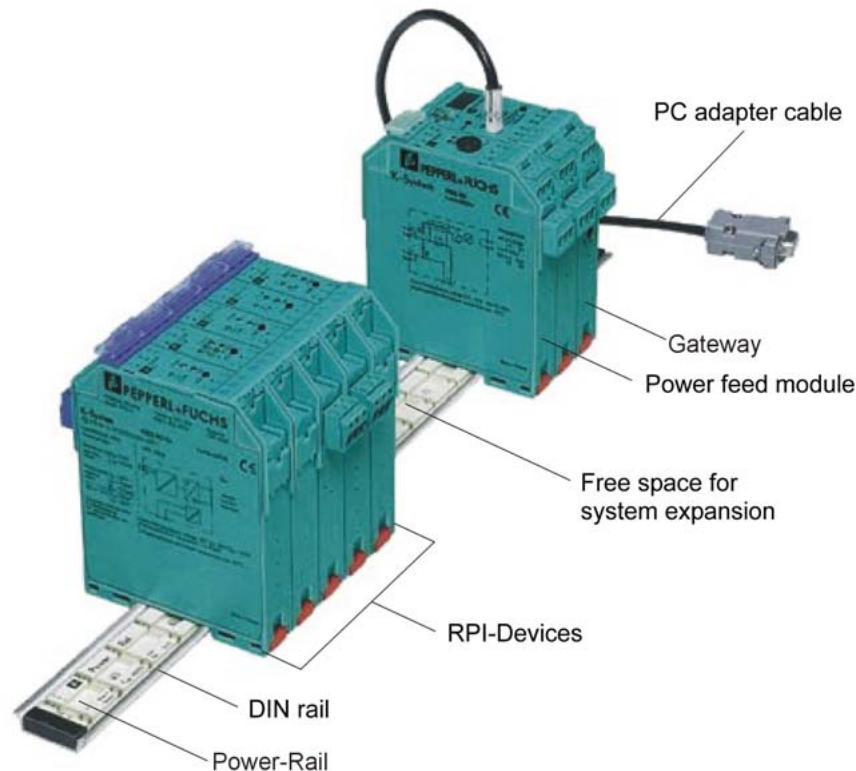

Figure 1.1:RPI system

In many production areas, relating to process automation, for example:

- chemical and petrochemical industry
- pharmaceutical and cosmetic industry
- paint production
- food industry and
- sewage treatment

but also in production areas relating to factory automation there are plants, in which a potentially explosive atmosphere exists. In order to ensure protection and safety and guarantee proper functioning in safe as well as in hazardous areas, RPI modules with intrinsically safe and non-intrinsically safe field circuits are available. In the case of the "intrinsic safety" category of explosion protection these signal conditioners are designed as isolator modules, which limit the electrical energy of the signal circuits in such a way that, even under specified fault conditions, the potentially explosive atmosphere cannot ignite.

The RPI system can be installed in a control room with a safe environment or in the field within Zone 2 of hazardous areas. Pepperl + Fuchs recommends the **PACT<sup>ware</sup>**™ software package as human machine interface for commissioning and operation of the RPI system. This software allows a simple configuration and parameter assignment of the RPI system by means of a PC notebook directly on the system or via a stationary engineering console in the control room.

A functional RPI system consists of:

1. Top hat DIN rail for mechanical installation, with Power Rail for voltage supply and internal bus connection of all modules.
2. Power feed module for coupling and monitoring the voltage supply. In the case of 24 V DC power supply no power supply units are required.
3. Gateway for coupling the system to one of the external bus systems:
  - PROFIBUS DP or PROFIBUS DP V1
  - MODBUS RTU or MODBUS Plus
  - ControlNet
4. RPI devices for both intrinsically safe and non-intrinsically safe field circuits are available for the following applications:
  - Analogue input 0/4 to 20 mA with or without transmitter power as well as with or without HART protocol transmission
  - Analogue input for resistance thermometers, thermocouples, potentiometric recorders and mV-transmitters
  - Analogue output 0/4 to 20 mA with or without HART protocol transmission
  - Binary input for mechanical contacts and proximity switches
  - Binary output for solenoid valves
  - Binary output for a potential-free relay contact
5. PC adapter for RS232 or RS485 as well as a suitable configuration software



Note

Please refer to **Chapter 2.2 "Intended Use"** and **Chapter 3.1 "System Structure and Principle of Operation"** for further details.

## 1.1 Availability, Functional Integrity and Function Monitoring

During the development of the Remote Process Interface we directed our special attention to electrical safety, system availability as well as functionality of the system:

- Redundant layout of the internal bus system.
- The use of two gateways per RPI bus line and two external bus branches, allows a completely redundant layout of the system.
- Redundant layout of the power supply with two power feed modules.
- Lead breakage- and short circuit monitoring of the signal circuits by means of the RPI devices.
- Error and status indication via LEDs on the front panel of all devices.
- In addition to an external bus interface the gateway allows the connection of a PC or notebook via service interface RS232 or RS485. A PC and an appropriate engineering tool constitute convenient tools for configuration, parameter assignment, simulation, test, and diagnosis purposes.
- Configuration, parameter assignment, simulation, test and diagnosis can also be carried out by way of the control system. Device and system failures are detected and signalled to the control system.

## 1.2 Aim of the Handbook

This handbook provides essential information and advice on how to plan, install and put the Remote Process Interface RPI into operation. In addition, it provides all necessary information on status and fault indi-

cations, on both device safety and monitoring functions as well as on fault diagnosis and fault elimination.



Note

The handbook requires knowledge and experience in the field of planning, configuring and design of bus systems as well as in the field of explosion protection. It cannot provide a basic introduction into the various bus systems or the fundamental principles of system planning or configuring. Users who require further information are recommended to refer to the relevant literature, the documentation of the bus and control system used or to the respective publications from Pepperl+Fuchs (see e.g. Explosion Protection Handbook Part.-Nr. 21417).

The RPI System Handbook provides essential information and advice on:

- Planning
- Installation
- Configuration
- Operation
- Safety
- Detection and elimination of faults

for the Pepperl+Fuchs Remote Process Interface (RPI).

This handbook applies in conjunction with the data sheets of the RPI modules that are used.

### 1.3 Notes on Using the Handbook

In order to enable you to familiarize yourself quickly with the RPI system and to have a rapid access to the necessary pieces of information, this handbook provides a detailed table of contents.

The following overview provides a short outline of the topics dealt with in the individual chapters:

#### **Operating Instructions in Brief**

Summarizes all important steps of a commissioning procedure and should be used by experienced users as a checklist for rapid commissioning, by means of the **PACT<sub>ware</sub><sup>TM</sup>** human machine interface.

#### **Chapter 1: Introduction**

explains the principle of operation of the RPI and provides an overview of the structure and aim of the handbook.

#### **Chapter 2: Safety**

explains the symbols used in the document, informs the user about potential dangers, the intended use of the device and its use within Zone 2 of the hazardous area.

#### **Chapter 3: Product Description**

describes the structure and the individual components of the RPI system in detail.

#### **Chapter 4: Planning of the RPI System**

shows the planning procedure in chronological order. It provides the information required for a mechanical and electronic assembly of the system and explains methods for determining the type and number of RPI devices needed.

#### **Chapter 5: Commissioning: Configuration**

explains the addressing of both the gateway and the devices via the keys and the display of the gateway.

#### **Chapter 6: Commissioning: Parameter assignment of the individual devices**

describes the commissioning procedure of the RPI system via the **PACT<sub>ware</sub><sup>TM</sup>** human machine interface.

#### **Chapter 7: Commissioning: Integration into the higher level bus system**

includes RPI specific information on integration into the standard bus systems PROFIBUS DP, PROFIBUS DP V1, MODBUS RTU, MODBUS Plus and ControlNet. The various service and diagnostic functions allow you to verify and correct faults with and without the higher level bus system.

#### **Chapter 8: RPI in Operation**

summarizes all service and diagnostic functions as well as fault signals. The simulation of measured values, and the display of measured values and trends are explained.

#### **Appendix A: Table of error codes**

lists all error codes shown in the display of the gateway.

#### **Appendix B: K-SK1**

Installation and operating principle of the "K-SK1" human machine interface

#### **Appendix C: Subject index**

#### **Appendix D: Glossary**

### 1.4 Prerequisites for RPI System Operation

The Remote Process Interface employs the most modern signal processing and transmission technologies. The RPI assumes a central position in providing safety in hazardous areas in which control and instrumentation equipment is installed.



Attention

When installing, commissioning, operating and maintaining RPI and MSR technology devices and device components in hazardous areas, the applicable construction and installation regulations (DIN EN 50020, DIN VDE 0165) must be observed.

Please consider all locally applicable regulations and directives when planning and configuring plants and systems abroad. Especially in North America other regulations and directives apply, than in the CENELEC member states.

As planner, installer and operator you are responsible for complying with all regulations and directives for potentially explosive environments.

### 1.5 Responsibilities of the User

Personnel undertaking commissioning should be familiar with the devices and both read and understand the handbook, prior to installing and commissioning the Remote Process Interface. Various procedures and instructions in this handbook require special precautions, in order to guarantee the safety of the persons involved.



Attention

The devices may only be operated and maintained by persons who are authorized due to their special training and qualifications and who have read and understood this handbook. In addition, these persons need an appropriate instruction by the operating authority of the plant!

Apart from this handbook, the relevant guidelines for the installation in hazardous areas should be observed.

The individual chapters of this handbook are aimed at persons with different qualifications, as listed below:

Chapter	Target Group, Qualifications
Chapter 1	Planners, personnel undertaking commissioning, process control engineers, service personnel
Chapter 2	Planners, personnel undertaking commissioning, process control engineers, service personnel
Chapter 3	Planners, personnel undertaking commissioning, process control engineers, service personnel
Chapter 4	Planners, personnel undertaking commissioning, process control engineers Broad knowledge of RPI, installation in hazardous areas, overvoltage protection and knowledge of the bus system
Chapter 5	Personnel undertaking commissioning, process control engineers, Broad knowledge of RPI, knowledge of the human machine interface
Chapter 6	Personnel undertaking commissioning, process control engineers Broad knowledge of RPI, knowledge of the human machine interface
Chapter 7.1	Process control engineers
Chapter 7.2	Process control engineers - PROFIBUS DP and DP V1
Chapter 7.3	Process control engineers - MODBUS RTU
Chapter 7.4	Process control engineers - MODBUS Plus
Chapter 7.5	Process control engineers - ControlNet
Chapter 8	Operator, service personnel

## 2 Safety

### 2.1 Safety Notes

#### 2.1.1 Explanation of the Symbols Used in This Document



Warning

This symbol warns of danger. If the instruction given in this warning is not heeded the result could be the serious injury of personnel and/or the severe damage or destruction of equipment.



Attention

This symbol warns of a possible fault. If the instruction given in this warning is not heeded, the device and any plant or systems connected to it could develop a fault or even fail completely.



Note

This symbol directs attention to important information.

#### 2.1.2 General Safety Regulations



Warning

When used as related apparatus in accordance with EN 50020, the prototype test certificate and the national installation regulations must be observed.

In addition, all applicable standards, directives and factory specifications as well as the relevant publications of the fieldbus user organisations, as for example the PROFIBUS user organisation PNO, ContronNet International etc. should be observed.

Repairs to devices with intrinsically safe circuits should only be carried out by expertly qualified personnel following the appropriate regulations.

We strongly recommend that repairs should be undertaken by the manufacturers. In the event of inadequate repairs being carried out, Pepperl+Fuchs GmbH will not honour the guarantee.

## 2.2 Intended Use

The Remote Process Interface is a system, which represents an interface between the conventional sensor and actor technology on one side and the process control system on the other side.

Measurement and control data is bidirectionally transmitted to the individual field devices via an internal bus and is made available to a higher level SPS or DCS. Various gateways are available for the individual bus systems. Connections to PROFIBUS DP, PROFIBUS DP V1, MODBUS RTU, MODBUS Plus and Control-Net are possible.

Various power feed modules are available for the voltage supply. They have to be chosen according to their intended usage. The maximum power supply for each line must not exceed 4 A and 2 A in the case of redundant power feed modules.

The RPI system is installed in the safe area or in the hazardous area of zone 2, in accordance with the approval.

The maximum length of the RPI internal communication lines must not exceed 8 m and the cable length of the power supply 10 m. Should these maximum lengths be exceeded, additional gateways and, possibly, power supply units have to be used.



Warning

The protection of operating personnel and plant is not guaranteed if the equipment is used for a purpose for which it was not intended.

The Remote Process Interface must only be operated by authorised specialist personnel in accordance with this equipment documentation (handbook, data sheet, certificate of conformity). The handbook constitutes the operating instructions in accordance with the Equipment Safety Law § 3 (3).

It applies in conjunction with the appropriate data sheets of the RPI modules.

## 2.3 Installation in a Potentially Explosive Atmosphere

The Pepperl+Fuchs Remote Process Interface can either be installed in a control room in the safe area or in the field within zone 2 of the hazardous area. See chapter 2.6 "Declaration of Conformity". It is suitable for intrinsically safe signals of zone 1 or 0 and for non-intrinsically safe signals.



Attention

Definition of Ex-zone 2:

An area in which, during normal operation, a potentially explosive gas atmosphere does not occur but seldom and only for a short-time.

According to the approval, the installation of the RPI system within zone 2 of the hazardous area, requires the installation in a single housing of protection class IP54 or higher.

Installation of the RPI system with a voltage supply in zone 1 can be carried out in a pressurized housing. For detailed information, please refer to Pepperl+Fuchs GmbH.

## 2.4 Installation Instructions for Use of the RPI System on Ships

The Pepperl+Fuchs RPI system must only be used in environments with ambient temperatures of -5 °C to +60 °C. It is not suited for installation in cold locations.

The input voltage must be 24V +30% -25%.

Please note the following during installation:

- The RPI system must be installed in a metallic control cabinet.
- A copper or steel sheet has to be mounted between the gateway (or in the case of a redundant system between the two gateways) and den RPI slaves.
- Another copper or steel sheet has to be mounted between the power feed module (or in the case of redundant supply between the two power feed modules) and the RPI slaves.
- The supply, communication, and I/O lines must be screened. The screen must be earthed and continued even inside the control cabinet up to the terminals (see drawing). In addition, all lines must be damped with a ferrite (e.g. Messrs. Würth Elektronik, type 742 700 5) between the earth of the screen and the exit from the control cabinet.
- I/O lines must not be conducted past the gateway.
- The earth connection of the power feed module has to be connected as short as possible.

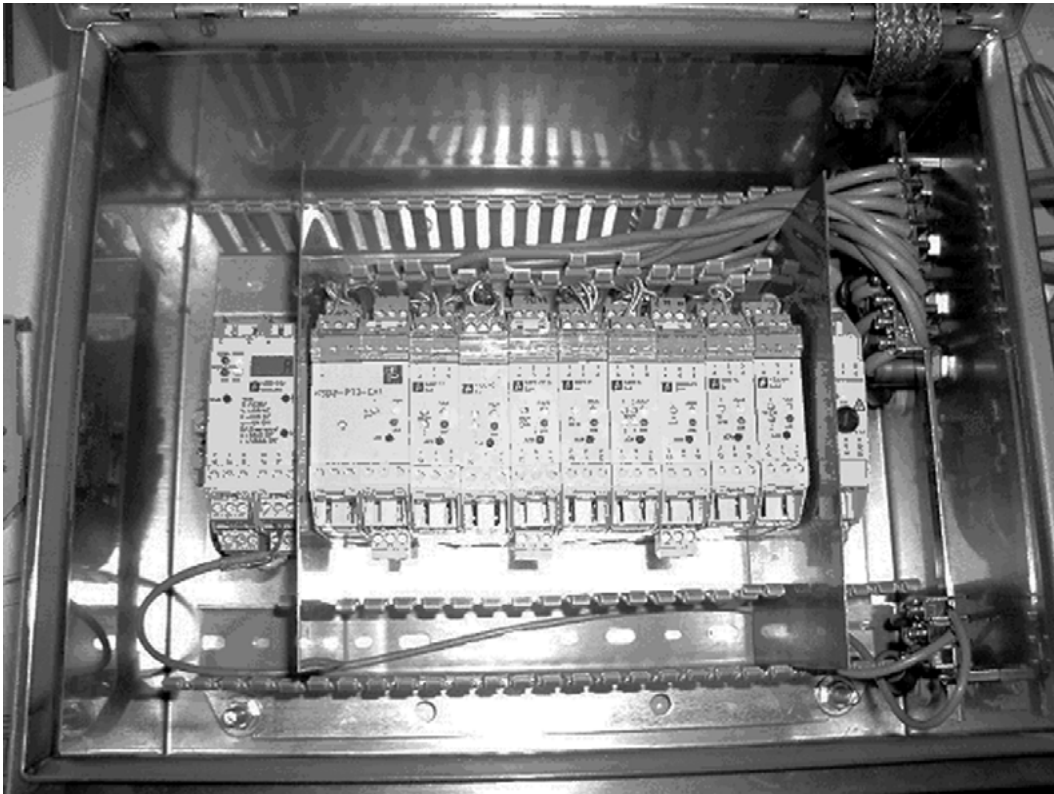

Figure 2.1: RPI system structure

Structure and configuration of the RPI system:

The system (see figure 2.1) consists of the following components:

Device No.	Model number	Description
1	KSD2-GW-MOD.485 KSD2-GW-MOD	MODBUS Gateway
2	KFD2-EB.MAR.RPI	Power Feed Module
3	KSD2-BO-Ex2.2 KSD2-BO-Ex	Solenoid Driver
4	KSD2-TI-Ex KSD2-VI KSD2-MVI	Converter
5	KSD2-CI-S-Ex.H	HART Transmitter Power Supply
6	KSD2-BI-Ex4 KSD2-BI-Ex2	Isolated Switch Amplifier
7	KSD2-FI-Ex	Current Frequency Converter
8	KSD2-CO-S-Ex.H KSD2-CO-Ex KSD2-CO-S-Ex	HART Analogue Driver/Repeater
9	KSD2-RO-Ex2	Relay Module
10	KSD2-CI-Ex2 KSD2-CI-S-Ex	Transmitter Power Supply
11	KSD2-PT2-Ex1	Potentiometer Input

## 2.5 Overvoltage and Lightning Protection

While planning the RPI system, the prevailing conditions in the field have to be tested in order to determine whether an overvoltage or lightning protection is required. If it is required, it has to be carried out in accordance with the relevant literature and regulations. Further information on overvoltage filters and lightning protection barriers to be snapped onto the top hat rail can be obtained from the Pepperl + Fuchs "DIN Rail Housing" catalogue.

## 2.6 Declaration of Conformity

Pepperl+Fuchs offers various devices and gateways for the modular Remote Process Interface (RPI). The different types of devices and gateways can be found in Chapter 'Product description' or in the Pepperl+Fuchs catalogue.

The TÜV 00 ATEX 1617X statement of conformity contains all device types of the RPI system without relay output for installation in Ex-zone 2 hazardous areas:

KSD2-BI-4	KSD2-GW-PRO
KSD2-BI-Ex2	KSD2-GW-PRO.485
KSD2-BI-Ex4	KSD2-GW-MOD
KSD2-FI-Ex	KSD2-GW-MOD.485
KSD2-BO-Ex	KSD2-GW-MPL
KSD2-BO-Ex2.2	KSD2-GW-MPL.485
KSD2-CI-S-Ex	KSD2-GW-CN
KSD2-CI-S-Ex.H	KSD2-GW-CN.485
KSD2-CI-2	KSD2-GW2-PRO
KSD2-CI-Ex2	
KSD2-TI-Ex	
KSD2-CO-Ex	
KSD2-CO-S-Ex	
KSD2-CO-S-Ex.H	
KSD2-HC	

The TÜV 00 ATEX 1618X statement of conformity refers to all device types of the RPI system with relay output as well as power feed modules for installation in Ex-zone 2 hazardous areas:

KFD2-EB2	KSD2-EB.RPI
KFD2-EB2.B	KSD2-EB-R2A.RPI
KFD2-EB.D1A.B	KSD2-RO-Ex2
KFD2-EB.D2A.B	
KFD2-EB.R2A.B	



Note

The current TÜV 00ATEX 1617X and TÜV 00 ATEX 1618X declarations of conformity can be obtained from Pepperl+Fuchs GmbH or downloaded as pdf-file from our website [www.pepperl-fuchs.com](http://www.pepperl-fuchs.com).

All products are developed and produced in accordance with the relevant European standards and directives.

The manufacturer of the product, Pepperl+Fuchs GmbH in 68307 Mannheim Germany, has a certified quality assurance system in accordance with ISO 9001.



ISO9001

## 2.7 Marking

The most important information from the data sheet can be found on the left housing side of the devices, as listed below:

Manufacturer Pepperl+Fuchs GmbH

Device type with part number

Marking in accordance with EC-Type Examination Certificate \*)

Device connection: Terminal assignment with the most important nominal values of the inputs and outputs

\*) not available for every device

### 3 Product Description

#### 3.1 System Structure and Principle of Operation

The Remote Process Interface (RPI) is an interface system for conditioning conventional control signals and signals from and to sensors, actuators and field devices on one side, and a bus system on the other side. The connection via a bus to the process control system or a programmable logic controller is carried out by means of gateways.

The RPI system is suitable for processing I/O-signals from a safe area or from a zone 1 or 0 hazardous area. The signals are galvanically isolated using RPI.

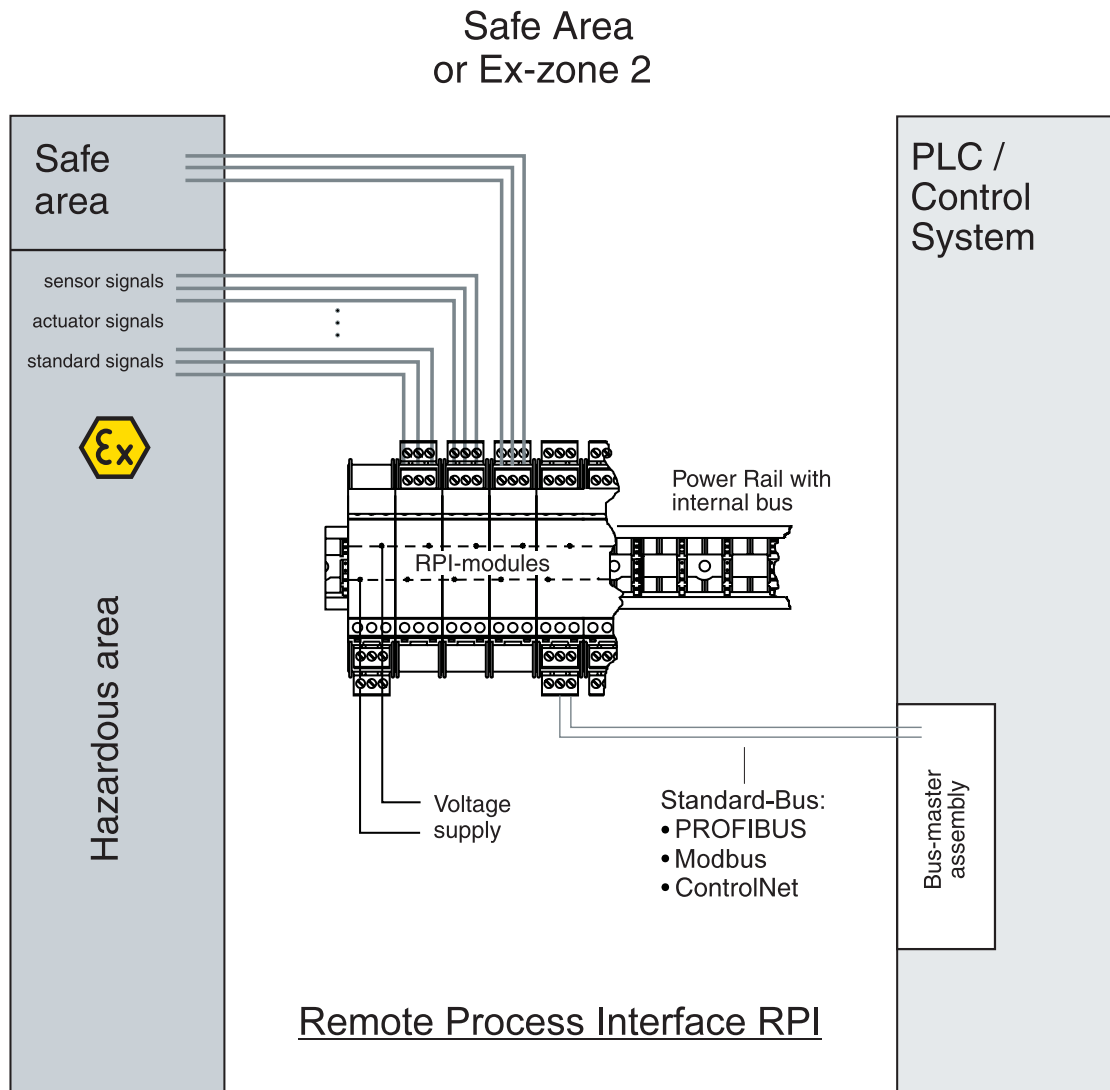

Figure 3.1: Structure of the Remote Process Interface (RPI)

##### 3.1.1 Modularity of the RPI System

A decided advantage of the RPI system is the high flexibility due to its modular structure. The DIN rail with Power Rail represents the basis of the RPI. The devices, gateways and power feed modules or power supply units are mounted on the DIN rail. Voltage supply and communication are established via the Power Rail. The DIN rail and the Power Rail can be mounted according to the prevailing conditions and cut to any required length. RPI devices with up to four signal channels are available for characteristic MSR technical tasks. See chapter 3.3 "Summary of RPI Modules Currently Available".

## 3.1.2 Integrated Signal Transfer and Mechanical Mounting: Power Rail

The Power Rail is available:

- as insert for the DIN rail according to DIN EN 50022 or
- as insert for the 35 x 15 mm top hat rail

Five conductors are integrated into the Power Rail. They have the following functions:

- 24 V DC voltage supply of the components snapped onto the rail (conductor 1 + and 2-)
- Transfer of the RPI internal communication bus (conductor 3 and 5)
- Transfer of the HART communication (conductor 4). In this case, K-system modules with centralized fault indications must not be installed, since they are likewise transferred via conductor 4.

## 3.1.3 Communication Between the RPI Modules

RPI uses an internal bus with a fixed transfer rate of 250 kbit/s. RPI allows up to 125 devices as bus stations. The gateway calculates the current cycle time according to the stored configuration. The time need is calculated in such a way that low-priority signals (acyclic services) can be transferred. The RPI internal bus system has a redundant design and switches to redundant transmission in the event of failure.

## 3.1.4 Gateways - Interface to an External Bus

By means of an RPI internal bus, all connected RPI devices communicate with the gateway, which exchanges the process data with the plant control, via a standard bus. The plant can be both a process control system (DCS) and a programmable logic controller (PLC). By using a second gateway, the bus connection to the higher-level bus system can also be made redundant. Gateways are available for the following standard busses:

- PROFIBUS DP
- PROFIBUS DP V1
- MODBUS RTU
- MODBUS Plus
- ControlNet

## 3.1.5 Voltage Supply via Power Feed Modules and Power Supply Units

Special power feed modules are mounted on the Power Rail for voltage supply. The number of power feed modules required depends on the current demand of the RPI modules, the spacial arrangement, and the need for a redundant design. In case 24 V DC are not available, suitable power supply units can be used. They are designed to supply the Power Rail directly and can be mounted on the rail. If the power supply units are mounted separately, voltage supply takes place via the power feed modules.

## 3.1.6 RPI Devices

The devices of the RPI system translate the signals of the connected field devices into the protocol of the RPI internal bus and vice versa.

In the case of devices with an intrinsically safe field circuit the signal line is safely galvanically isolated between the hazardous and the safe area in the RPI device. The signals for the hazardous area are intrinsically safe in accordance with ignition protection class ia or ib.

In addition, a signal preprocessing can be set by means of a parameter assignment of the RPI devices.

## 3.1.7 HART Protocol Transmission

The HART protocol is used to program HART compatible field devices. These field devices are able to carry out calculations, self-diagnoses and error reports. Suitable RPI modules are available for the transmission of the HART protocol.

### 3.1.7.1 HART Programming Unit With Direct Connection

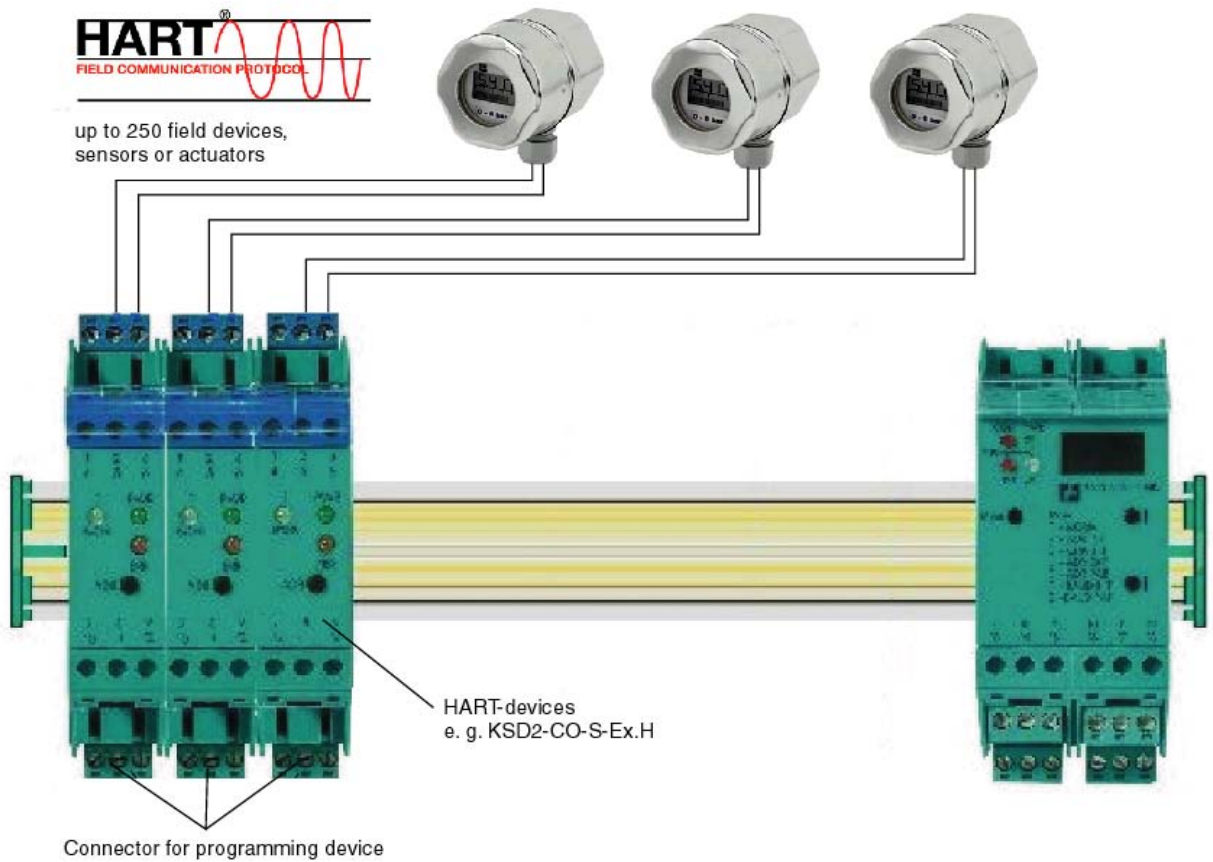

Figure 3.2: Connection of the HART programming unit to the terminals of the RPI device

The RPI devices are equipped, as standard, with the appropriate terminals for the connection of the programming unit. The connection can be established on the safe side.

### 3.1.7.2 Transmission via HART Multiplexer

The HART protocol is transferred by the KFD2-HMM-16 HART multiplexer master to the KSD2-HC HART control module and further on to the RPI module via rail 4 of the Power Rail.

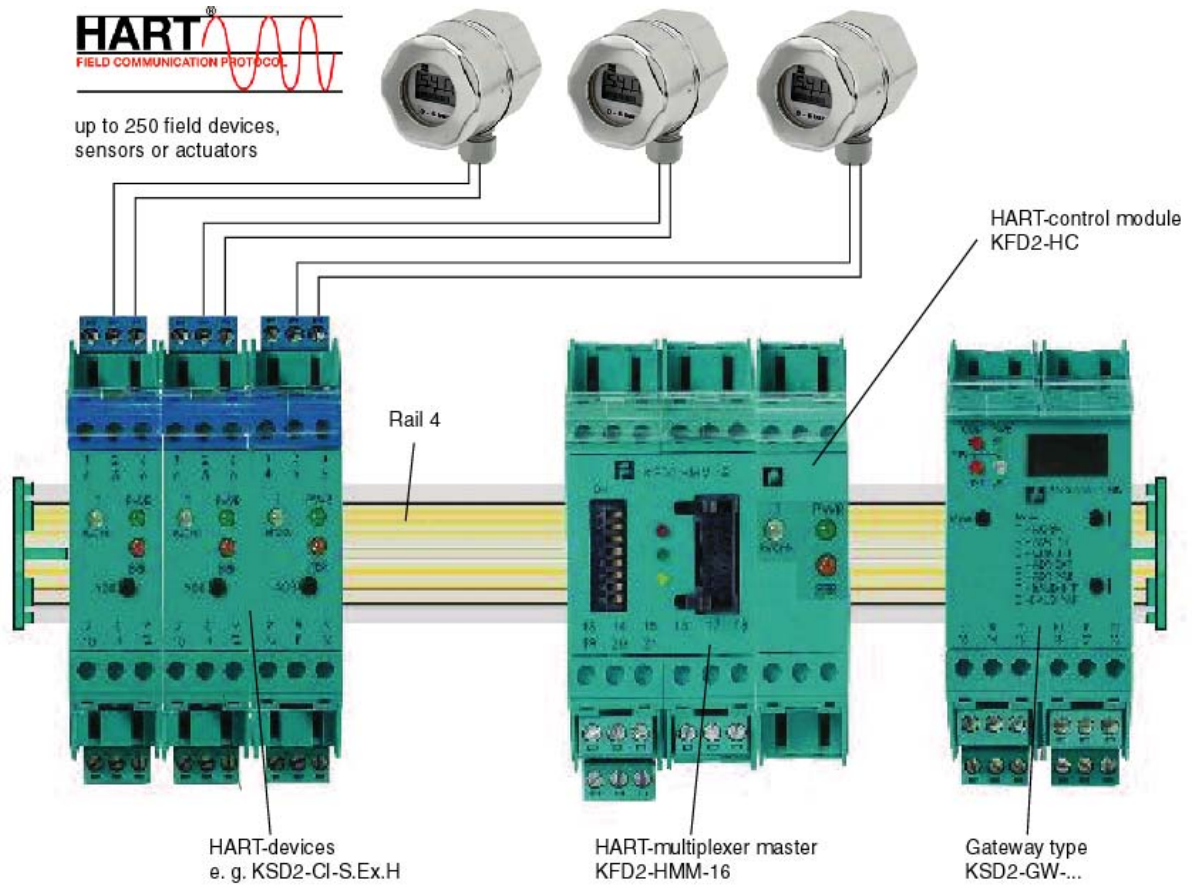

Figure 3.3:HART multiplexer master and HART control module

### 3.1.7.3 HART Transmission via PROFIBUS

The PROFIBUS DP V1 gateway KSD2-GW2-PRO has an integrated HART multiplexer system that offers full functionality. The transmission of the HART protocol is carried out through

- PROFIBUS DP V1 or
- the RS485 service interface

to the control system or a connected engineering console. Within the RPI system the HART protocol is transferred via rail 4 of the Power Rail to the RPI devices.

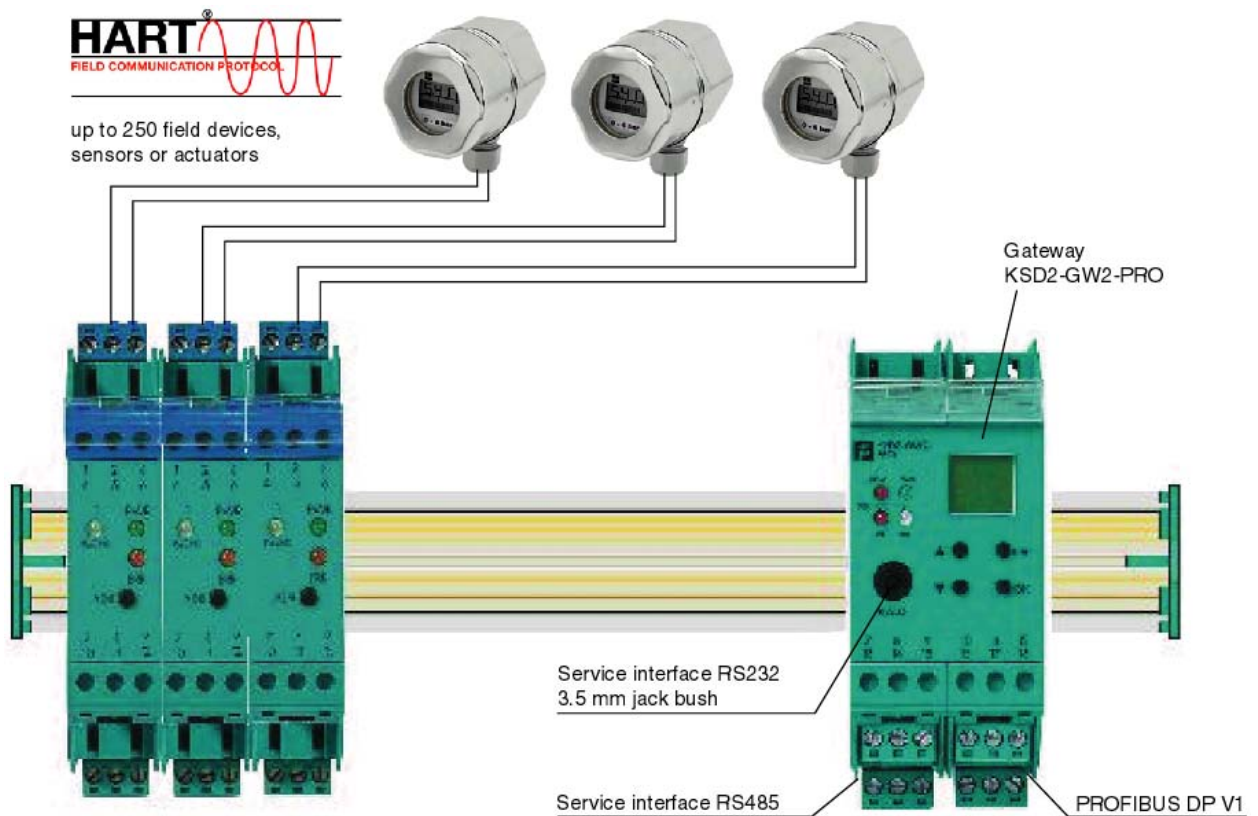

Figure 3.4: PROFIBUS DP V1 gateway KSD2-GW2-PRO

## 3.2 Performance Characteristics

### 3.2.1 Overview of the RPI System Characteristics

- |                    |   |
|--------------------|---|
| Power feed modules | <ul style="list-style-type: none"> <li>• 2 A or 4 A output current</li> <li>• 24 V DC power supply</li> <li>• Supply of the RPI modules on the Power Rail</li> <li>• Group fusing via a fine-wire fuse</li> <li>• Alarm relay output for defective fuse</li> </ul>  |
| Power supply units | <ul style="list-style-type: none"> <li>• 4 A output current at 24 V DC output voltage</li> <li>• 90 to 253 V AC input voltage</li> <li>• Supply for the modules on the Power Rail</li> <li>• Group fusing provided by miniature fusing</li> </ul>   |
| Gateways           | <ul style="list-style-type: none"> <li>• Master function for the RPI internal bus</li> <li>• Couples internal bus to external standard bus system</li> <li>• External bus systems:               <ul style="list-style-type: none"> <li>- PROFIBUS DP</li> <li>- PROFIBUS DP V1 with HART transmission</li> <li>- MODBUS RTU</li> <li>- MODBUS Plus</li> <li>- ControlNet</li> </ul> </li> <li>• Slave functionality on external bus</li> <li>• Storage of the configuration and parameters of all RPI modules in an internal EEPROM</li> <li>• Configuration of the overall RPI system both via integrated RS232 or RS485 service interface and external bus</li> <li>• Diagnosis and error messages via LEDs and communication via external bus, and the service interface</li> <li>• Redundant external bus with second gateway</li> </ul> |
| RPI devices        | <ul style="list-style-type: none"> <li>• 1...4 channel interface modules for the transfer of digital and analogue I/O data between the safe and the hazardous areas</li> <li>• Non-Ex modules are also available</li> <li>• Special modules for direct connection of transmitters, temperature sensors, valves, contacts and inductive proximity switches</li> <li>• Bi-directional transmission for HART signals</li> <li>• Integrated lead breakage and short circuit monitoring</li> <li>• Integration of instrumentation functions such as alarm and error limit values, calibration, linearisation, etc.</li> <li>• Diagnosis and error messages via LEDs and communication via the internal bus to the gateway and via the external bus, to the DCS or PLC or via the service interface to the PC.</li> </ul>                           |

**3.2.2 Flexibility by Virtue of Modularity**

- Device combinations
  - RPI modules having various functions can be arbitrarily attached to the Power Rail assembly
  - All modules can easily be snapped-on the Power Rail
  - Marshalling of the signal current circuits is not necessary
  - Combinations with devices of the Pepperl+Fuchs K-system are possible
  
- Number of RPI bus stations
  - Up to 125 RPI devices on one RPI line
  - 1 active RPI gateway per RPI line
  - 1 redundant passive gateway per RPI line (option)
  - Larger assemblies can be achieved by coupling a number of RPI bus lines together on the external bus.

**3.2.3 Internal and external communication**

- Transfer rate, internal
  - 250 kbit/s
  
- Transfer rate, external
  - Dependent on the bus system used, See chapter 7 "Integration into the Higher-Level Bus System"
  
- Transfer rate of the RS 232/RS 485 interface
  - Adjustable: 1.2 kbit/s, 2.4 kbit/s, 4.8 kbit/s, 9.6 kbit/s, 19.2 kbit/s, 28.8 kbit/s, 33.6 kbit/s, 38.4 kbit/s; 57.6 kbit/s
  
- Cycle time
  - From the gateway, via the external bus to the control system, depending on the bus system used and its baud rate, see Chapter 4 'Planning'
  - From the device, via the internal bus to the gateway, or the reverse:
 

1	Device	25 ms
125	Devices with up to 4 binary inputs	60 ms
125	Devices with up to 2 binary outputs	90 ms
125	Devices with 1 analogue input	75 ms
125	Devices with 1 analogue output	110 ms

Please refer to Chapter 4.4 "Calculating the RPI Cycle Time" for the precise calculation of the cycle time.

**3.2.4 Electrical Safety**

- Wiring
  - The significantly reduced amount of wiring by comparison with conventional systems, results in a corresponding reduction in the probability of wiring faults
  
- Fusing
  - Group fusing via a fuse in the power feed module
  - Tripping of the fuse is indicated by an LED and can be communicated to the control system via a relay output
  
- EMC
  - All RPI devices satisfy the requirements of DIN EN 50 081 - 2, DIN EN 50082-2, NAMUR NE 21
  
- Ex-Protection
  - All devices identified by 'Ex' in the type code have circuits which are approved for use in the hazardous area and are designed as "intrinsically safe" equipment.

Date of issue 05/27/03

### 3.2.5 System Availability

- |                                  |   |
|----------------------------------|---|
| Internal RPI bus                 | <ul style="list-style-type: none"> <li>• Standard redundant design of the internal bus</li> <li>• The bus signals are transferred between the two bus lines of the Power Rail as voltage difference signals</li> <li>• If this transfer route fails due to lead breakage or short circuit between the two bus lines, or due to a defective coupler, the system switches automatically to common-mode operation, in which the negative potential of the supply voltage provides a reference.</li> </ul>  |
| External standard bus            | <ul style="list-style-type: none"> <li>• Redundant design due to the use of a second gateway. The configuration data and parameters of the RPI system are also stored in non-volatile memory in the redundant gateway.</li> </ul>   |
| Fault finding                    | <ul style="list-style-type: none"> <li>• Error messages via LEDs on the front panel of all devices</li> <li>• Extensive possibilities for diagnosis via the configuration interface on the gateway, with <b>PACT<sub>ware</sub></b><sup>TM</sup> Edition 2 and Device Type Manager (DTM) for the RPI system.</li> <li>• Transfer of all error and status messages to the control system via the external standard bus system.<br/>Thus, it is possible to reduce the time required for locating faults and equipment defects to a minimum.</li> </ul> |
| Replacement of defective devices | <ul style="list-style-type: none"> <li>• A defective RPI module is simply replaced with one of similar type</li> <li>• Due to the removable terminal blocks, there is no need to unfix any cable glands</li> <li>• When replacing a device, the device address and the device parameters are automatically transferred by the gateway to the new module</li> <li>• When replacing a gateway, the complete parameter and configuration data set is transferred automatically to the new gateway via the service interface</li> </ul>                   |

### 3.2.6 Configuration and Parameter Assignment

- |  |   |
|--|---|
| Device addresses                             | <ul style="list-style-type: none"> <li>• The address of the RPI system on the external bus is set on the gateway.</li> <li>• The addresses of the devices and gateways on the RPI internal bus can be set               <ul style="list-style-type: none"> <li>- via keys and the LCD-display of the gateway</li> <li>- via PC and configuration software or</li> <li>- via the external bus</li> </ul> </li> </ul> |
| Device parameters and RPI configuration data | <ul style="list-style-type: none"> <li>• Using the PC and <b>PACT<sub>ware</sub></b><sup>TM</sup> human machine interface or by the control system via the external bus. The DTM can be integrated into every configuration tool that supports the FDT (Field Device Tool) technology.</li> </ul>   |

### 3.3 Summary of RPI Modules Currently Available

Currently devices are available within the RPI system for all instrumentation, control and monitoring applications. However, the RPI system will be continuously extended in order to satisfy customer requirements. The RPI system can be combined with Pepperl+Fuchs K-system devices, thus covering a large number of special applications. Further information can be obtained directly from Pepperl+Fuchs.

#### 3.3.1 230 V AC Power Supply Units

- KFA6-STR.1.24.4      4 A Power Supply Unit

#### 3.3.2 24 V DC Power Feed Modules

- KFD2-EB.RPI            4 A Power Feed Module with bus pick-off
- KFD2-EB.R2A.RPI      2 A Power Feed Module with bus pick-off for redundant voltage supply from two power supplies

#### 3.3.3 Isolated Switch Amplifiers

- KSD2-BI-Ex2            2 channel Isolated Switch Amplifier with Ex approval
- KSD2-BI-Ex4            4 channel Isolated Switch Amplifier with Ex approval
- KSD2-BI-4                4 channel Isolated Switch Amplifier for the connection of passive contacts
- KSD2-BI-4.2             4 channel Isolated Switch Amplifier for the connection of proximity switches and mechanical contacts

#### 3.3.4 Solenoid Drivers and Relay Modules

- KSD2-BO-Ex            1 channel Solenoid Driver with Ex approval
- KSD2-BO-Ex2.2        2 channel Solenoid Driver with Ex approval
- KSD2-RO-Ex2          2 channel Relay Module with Ex approval
- KSD2-RO-2              2 channel Relay Module

#### 3.3.5 Transmitter Power Supplies

- KSD2-CI-S-Ex          1 channel SMART-Transmitter Power Supply with Ex approval
- KSD2-CI-S                1 channel SMART-Transmitter Power Supply
- KSD2-CI-2                2 channel Transmitter Power Supply
- KSD2-CI-Ex2            2 channel Transmitter Power Supply with Ex approval
- KSD2-CI-S-Ex.H        1 channel HART-Transmitter Power Supply with Ex approval, SMART via terminals, HART via Power Rail and terminals
- KSD2-CI-S-H             1 channel HART-Transmitter Power Supply, SMART via terminals, HART via Power Rail and terminals

#### 3.3.6 Analogue Driver/Repeater

- KSD2-CO-Ex            1 channel Analogue Driver/Repeater with Ex approval
- KSD2-CO                 1 channel Analogue Driver/Repeater
- KSD2-CO-S-Ex         1 channel SMART Analogue Driver/Repeater with Ex approval
- KSD2-CO-S              1 channel SMART Analogue Driver/Repeater
- KSD2-CO-S-Ex.H      1 channel HART Analogue Driver/Repeater with Ex approval, SMART via terminals, HART via Power Rail or terminals
- KSD2-CO-S-H           1 channel HART Analogue Driver/Repeater, SMART via terminals, HART via Power Rail or terminals

### 3.3.7 Current Frequency Converters, Batch Controllers, Flow Meters

- KSD2-FI-Ex            1 channel Current Frequency Converter with Ex approval for the connection of proximity switches and digital sensing elements, e.g.: optical or mechanical
- KSD2-FI                1 channel Current Frequency Converter for the connection of proximity switches and digital sensing elements, e.g.: optical or mechanical

### 3.3.8 Temperature Converters

- KSD2-TI-Ex            1 channel Universal Temperature Converter with Ex approval
- KSD2-TI                1 channel Universal Temperature Converter

### 3.3.9 Voltage Converter

- KSD2-VI                1 channel Voltage Converter with a voltage range of 0/2 ... 10 V.

### 3.3.10 Gateways

- KSD2-GW-PRO        PROFIBUS DP-Gateway with RS 232 service interface
- KSD2-GW-PRO.485    PROFIBUS DP-Gateway with RS 485 service interface
- KSD2-GW2-PRO        PROFIBUS DP V1-Gateway with RS 232 and RS 485 service interface and full transmission for HART Protocol
- KSD2-GW-MOD        MODBUS-Gateway RTU with RS 232 service interface
- KSD2-GW-MOD.485    MODBUS-Gateway RTU with RS 485 service interface
- KSD2-GW-CN         ControlNet-Gateway with RS 232 service interface
- KSD2-GW-CN.485     ControlNet-Gateway with RS 485 service interface
- KSD2-GW-MPL        MODBUS PLUS-Gateway with RS 232 service interface
- KSD2-GW-MPL.485    MODBUS PLUS-Gateway with RS 485 service interface

### 3.3.11 HART Modules

- KFD2-HMM-16        HART-Multiplexer Master
- KSD2-HC              HARTControl Module

## 3.4 Commissioning Procedure for the RPI System

Commissioning of the RPI system is carried out in three steps:

1. Configuration
2. Parameter assignment
3. Integration into the higher level-bus system.

The RPI system can be configured via the RS 232 or RS 485 service interface of the RPI gateway and each channel of each RPI device can be parameterized individually.

For simple and rapid commissioning Pepperl+Fuchs offers the **PACTware™** software package. **PACTware™** (Process Automation Configuration Tool) is an open source software with open FDT-interface (Field Device Tool), which facilitates the multi-vendor and uniform configuration of modern field devices. Detailed information on **PACTware™** is given in Chapter 4.8.3 "**PACTware™**".

### 3.4.1 Configuration

- Address assignment of the RPI gateway on the higher-level bus
- Address assignment of the RPI modules on the in-system bus
- Definition of the communication with the higher-level bus
- Definition of the communication via the RPI service interface
- Adjustment of the redundancy mode

Usually, the configuration is carried out via the operator level of the gateway.

### 3.4.2 Parameter Assignment

- Simulation of the structure of the RPI system in the commissioning software
- Adjustment of the individual RPI modules to the requirements of sensors, actuators and field devices

### 3.4.3 Integration into the Higher-Level Bus System

- is described, depending on the bus system used, in the respective chapters of this handbook.

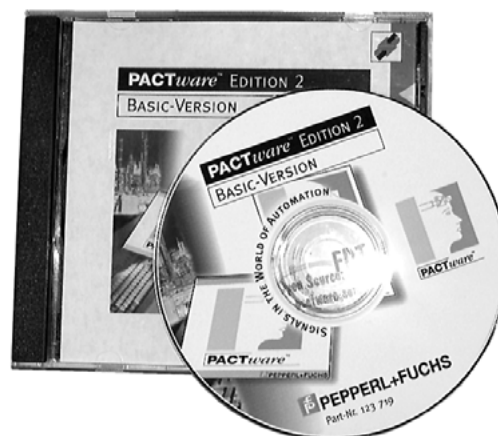

Figure 3.5: **PACTware™** - the human machine interface for the Remote Process Interface

## 3.5 Control Cabinets: Assembly and Service

Pepperl+Fuchs offers fully assembled and tested control cabinet systems. They are equipped with RPI devices according to customer requirements and based on measurement, and automatic control engineering. Local Pepperl+Fuchs sales offices will be pleased to advise on alternative installations and the most suitable control cabinet layout for a given application.

The following diagram shows a possible arrangement of an RPI system in a control cabinet.

Detailed view

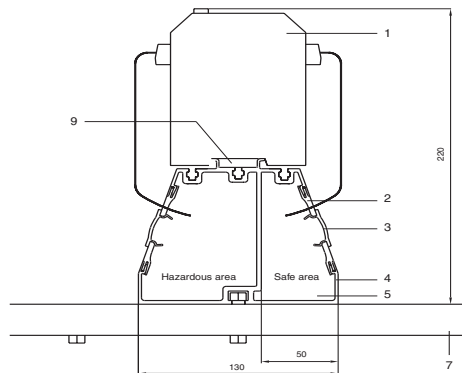

1. KS module
2. Wiring comb for direct wiring to the KS modules
3. Comb cap
4. KF profile
5. Space for connection cable: field cable für Ex and non-Ex signals
6. Spacer bolts for mounting in control cabinets
7. Mounting plate
8. Terminal
9. Power Rail

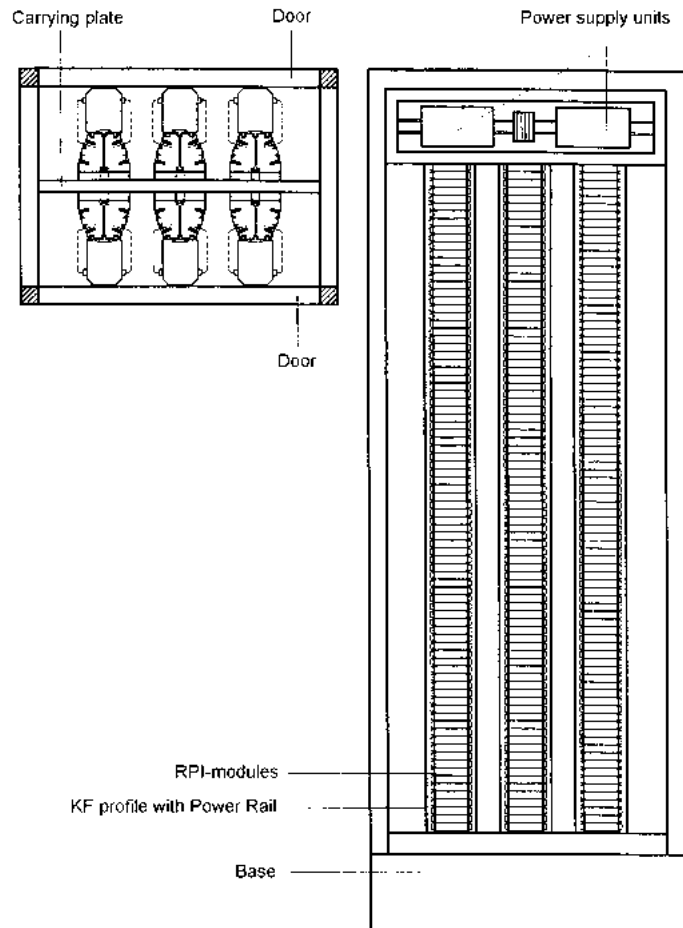



Figure 3.6: Possible arrangement of an RPI system in a control cabinet

**PLANNING, COMMISSIONING, CONFIGURATION AND PARAMETER ASSIGNMENT**

**4 Planning of the RPI System**

 Pepperl+Fuchs offers planning and mounting of complete control cabinet systems for the assembly of RPI systems.  
Local Pepperl+Fuchs sales offices will be pleased to advise on alternative installations and the most suitable control cabinet layout for a given application.

**4.1 Planning - Basics and Procedure**

Figure 4.1 shows how to proceed when planning an RPI system. The individual steps are explained in the following chapters, whose numbers are given in the diagram below.

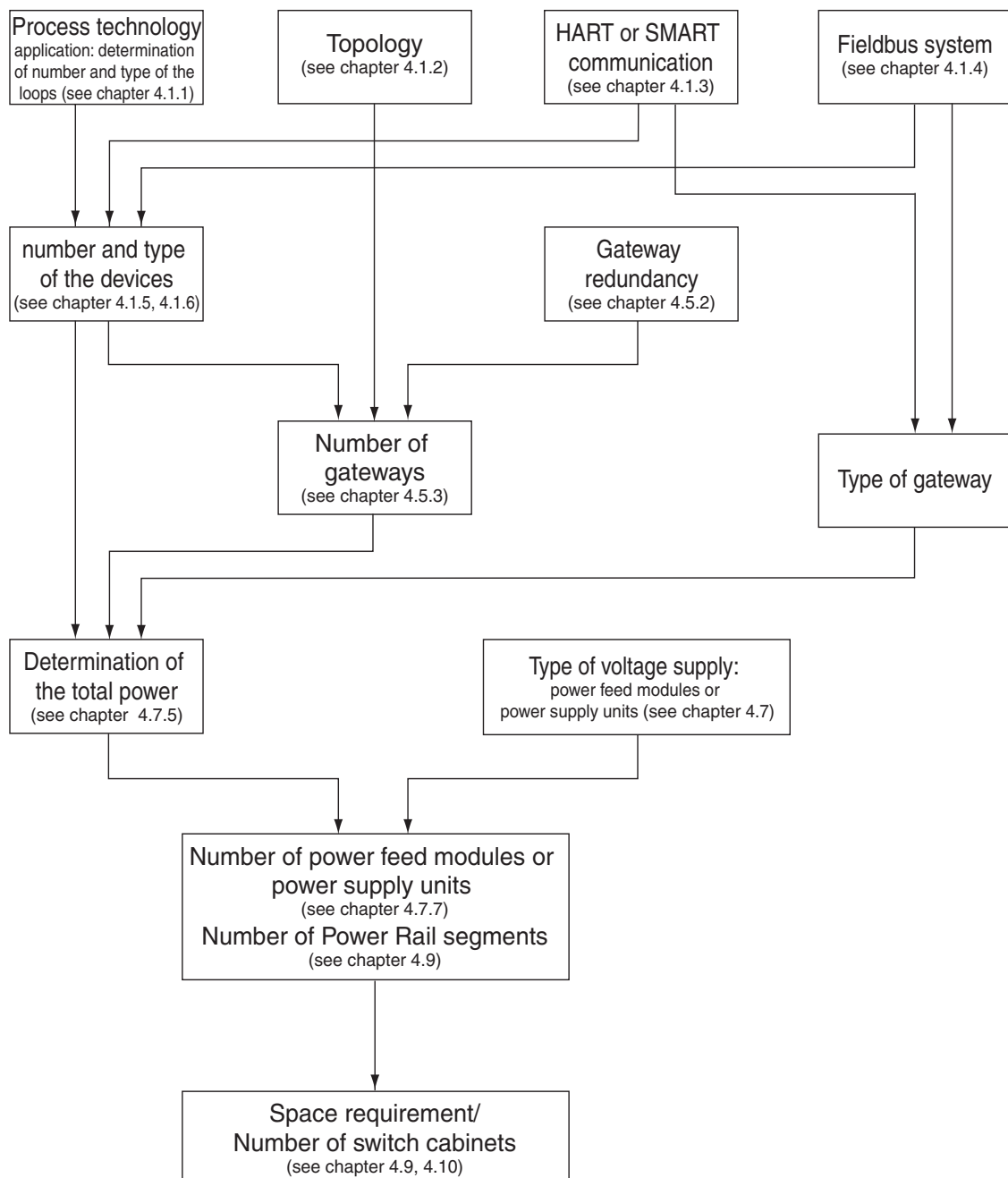

Figure 4.1: Planning procedure

Date of issue 05/27/03

## 4.1.1 MSR Technology

First of all, you should determine the type and number of measuring points, field devices, actuators and control circuits required for the application. They are intended to communicate with the higher-level process control system

or with the PLC via the RPI system. The individual sensors and actuators are connected to the RPI devices using conventional wiring. The kind of information on system side devices, required for a parameter assignment of the RPI system, depends on the RPI devices to be used and is explained in **Chapter 4.1.5 "Establishing the Measuring Ranges, Basic and Miscellaneous Functions"**.



Safety-related signals

You should begin the planning process by clarifying which signals are safety-related and which national specifications are applicable.

## 4.1.2 Topology

The structure of the plant and the spacial conditions determine the subsequent layout

of the RPI system. You should determine, whether to accommodate the system in a control room or split it up

and arrange it at different sites or in the field. Splitting it into several systems enables larger applications to be divided into logical functional units and reduces the amount of wiring, as the individual systems can be positioned closer to each field device.

## 4.1.3 HART Communication

The application of HART compatible field devices has to be taken into account when selecting the RPI devices and the gateway. Suitable RPI devices have to be used for the transmission of the HART protocol.

Detailed information on various ways to transfer the protocol is provided in **Chapter 4.2 "Planning the Transmission of HART Protocols"**.

## 4.1.4 Fieldbus and Subordinate Service Level

The fieldbus used is a decisive factor in selecting the gateways to be employed. The RPI system can be integrated into the following fieldbusses:

- PROFIBUS DP
- PROFIBUS DP V1
- MODBUS RTU
- MODBUS Plus
- ControlNet

When selecting a gateway, it is necessary to determine the structure of a service level simultaneously. The KSD2-GW-... gateways have an RS 232 or an RS 485 service interface. The RS 485 interface allows up to 31 gateways to be networked with a PC. It is possible to wire a point-to-point connection between a gateway and a PC via the RS 232 interface, or to connect a notebook directly to a gateway by means of a 3.5 mm jack .

The KSD2-GW2-PRO gateway has both types of interfaces.

It is also possible to carry out a configuration and parameter assignment via PROFIBUS DP or PROFIBUS DP V1. Further information can be found in **Chapter 7.2.2 "Gateway KSD-GW2-PRO"** and **Chapter 7.2.8 "GSD Files"**.

## 4.1.5 Establishing the Measuring Ranges, Basic and Miscellaneous Functions

Now that the sensors and actuators are known, the details are defined for each sensor, field device and actuator. The general data structure of the RPI devices can be entered or read out by means of a configuration tool, e.g.

**PACT<sub>ware</sub>**<sup>TM</sup> Edition 2, or by way of the control system via the gateway.

The data structure of each RPI device occupies the following areas:

- Process data (input/output data)
- Device parameters
- Channel-specific parameters
- Device diagnostic information
- Channel-specific diagnostic information
- Device command data area

The applicable data areas and specific requirements of individual device types are explained below:

#### 4.1.5.1 Process Data

The process data contains the binary or analogue input or output data of all the channels on the devices, e.g. the value measured by a temperature converter. This data depends on the RPI device type.

#### 4.1.5.2 Device Parameters

The device parameters contain individual and detailed data for the relevant device:

- Device type, device ID,
- Serial number, software/hardware revision number, part number
- Number of channels, type and structure of the input/output data,
- HART support

#### 4.1.5.3 Channel-Specific Parameters

The channel-specific parameters contain data which is specific to a measuring point. This data can be individually set when programming the RPI devices using the human machine interface or via the higher-level control system:

- Measuring point description (TAG No.)
- Comment
- Sensor type, connection system
- Comment
- Measuring range
- Damping
- Lead short circuit/lead breakage monitoring (not on all devices)
- Low/high signal warning, low/high signal alarm for analogue inputs
- Input/output status in the error case
- Calibration of the measuring range
- Linearization of measured value, cold junction compensation on thermocouples
- Physical unit of the analogue input parameters
- Hysteresis for falling short of/exceeding the limit value
- Lower and upper value of the measuring range (0% measured value or 100% measured value)
- Inversion of the input signals
- Cold junction compensation internal/external
- User-specific linearization
- The input value can be overwritten in a defined way for simulation purposes

#### 4.1.5.4 Device and Channel-Specific Diagnostic Information

The diagnostic information contains detailed data on device and channel status:

- Internal device error messages, status of the bus communication, configuration errors
- Separate messages for lead breakage and short circuiting
- Overrange and underrange alarm, alarm for exceeding/falling short of limit value



Detailed information on the data structure of the individual modules is given in **Chapter 6 "Parameter Assignment"**.

Note

#### 4.1.5.5 Overview of Functions and Miscellaneous Functions for Each RPI Device

The information provided in the tables below is required for the selection and parameter assignment of RPI-devices. See also **Chapter 6.1 "Parameters of the RPI Modules"**

Device designation Function	Type code	No. of channels	available in		Sensor settings	Output settings
			Ex	non-Ex		
Isolated switch amplifier	KSD2-BI-...	2 or 4	yes	yes		Invert signal , filter time
Frequency converter	KSD2-FI-...	1	yes	yes	Unit, operating mode	Measuring range: unit constant, offset
Solenoid driver	KSD2-BO-...	1 or 2	yes	no		invert signal
Relay module	KSD2-RO-...	2	yes	yes		invert signal
Transmitter power supply	KSD2-CI-...	1 or 2	yes	yes	Unit, current range, connection method: 2 or 3-wire transmitters, 2-wire current source	Measuring range: start, end HART transmission
Temperature converter	KSD2-TI-...	1	yes	yes	Sensor type, connection method , unit, linearization, reference junction internal/external	Measuring range: start, end invert signal
Voltage converter	KSD2-VI	1	no	yes	Unit, voltage range	Measuring range: start, end
Analogue Driver/ Repeaters	KSD2-CO-...					

Table 4.1: RPI devices and functions

Type code	Measuring station	Lead monitoring		Limit-value monitoring		Output status when fault occurs					
		Brea-kage	Short-circuit	Warnin g limits	Alarm limits	Upsca- led	Down- scaled	Main- tain last value	As input	Mini- mum	Maxi- mum
KSD2-BI-...	32	yes	yes			x	x	x			
KSD2-FI-...	32	yes	yes	yes	yes			x	x		
KSD2-BO-...	32	yes	yes			x	x	x			
KSD2-RO-...	32					x	x	x			
KSD2-CI-...	32	yes	yes	yes	yes			x	x	x	x
KSD2-TI-...	32	yes	yes	yes	yes			x	x	x	x
KSD2-VI	32	yes		yes	yes			x	x	x	x
KSD2-CO-...	32	yes	yes					x	x	x	x

Table 4.2: Miscellaneous functions of the RPI devices

## 4.1.6 Selecting the RPI Devices

Now that you have determined the functions and miscellaneous functions as described above, you can select the individual RPI devices according to the following procedure:

1. Device type: Which sensor, actuator or field device must the RPI-device support?
2. Is the sensor, actuator or field device located in a hazardous area?



Not all of the devices in the RPI system are certified for application in the hazardous area.

When selecting appropriately certified devices for the hazardous area, attention must be paid to the permitted connection values, the class of ignition protection and the category.

3. Is a HART or a SMART protocol transferred? (see **Chapter 4.2 "Planning the Transmission of HART Protocols"**)
4. Which requirements of the control system must the RPI modules meet? (see **Chapter 7.2.8 "GSD Files"**)
5. Is it possible to use multi-channel devices?  
The **PACT<sup>ware</sup>**™ software enables the devices to be parameterized channel by channel and thus to connect a number of field devices of the same type with different parameter assignments to an RPI device. For information on the type of multi-channel devices available, please refer to **Chapter 4.1.7 "Establishing the Miscellaneous and Monitoring Functions for the Operation"**
6. List of all RPI modules required with the full type code and, if available, with the corresponding measuring point description.

The planning can be developed, as usual, by measuring station numbers, since these can be transferred to the RPI and used in further working steps.

After having defined the basic functions and device types mentioned above, you can already start planning, configuring and programming the RPI system offline on your PC using the **PACT<sup>ware</sup>**™ human machine interface.

For the rare case that specific functions are not supported by the RPI, devices from other systems can be linked by the RPI. The Pepperl+Fuchs team will be happy to provide appropriate solutions.

## 4.1.7 Establishing the Miscellaneous and Monitoring Functions for the Operation

In addition to the basic functions described in the chapter above, the RPI devices also support a series of miscellaneous functions, which can be activated and set. The miscellaneous functions available are listed in Table 4.2: on page 38.

It must be decided which of these messages are to be displayed or processed in the control system and which are merely required to be seen on the RPI human machine interface..



Detailed information on the setting of these parameters and the various register cards of the devices is given in **Chapter 6 "Parameter Assignment"**

Note

Full technical data on the devices can be obtained from the data sheets in our catalogue or from our website: [www.pepperl-fuchs.com](http://www.pepperl-fuchs.com)

## 4.1.8 Layout and Addressing of the RPI Devices

Having determined the individual types and numbers of RPI devices needed, and the type of gateway required, the possible layout of the RPI-system and the arrangement of the individual devices should be specified.

Especially when several RPI systems are used, we recommend dividing the RPI devices into logical functional units. When arranging the system, devices of the same type should be combined into groups. The signals will be marshalled on the software side.

In this working step the RPI-internal addresses should be determined and recorded in the plan. (see **Chapter 5.4.2.1 "ALLOCATION OF THE DEVICE ADDRESSES ON THE INTERNAL BUS"**)

The device addresses are organised as follows:

Address	Device
0	Neutral address of an RPI device, (the setting on delivery)
1	Active RPI gateway
2	Redundant RPI gateway
3 ... 127	RPI device

Table 4.3: Organisation of the RPI device addresses

## 4.1.9 Determining Where to Install the RPI System

The RPI system can be installed either in the safe area of the control room or in the zone 2 hazardous area of the plant.

The installation of the RPI system within Ex-zone 2 must be undertaken with due regard for the statement of conformity (TÜV 00 ATEX 1617X or TÜV 00 ATEX 1618X). Only devices with an appropriate statement of conformity can be installed in zone 2. Detailed information is given in **Chapter 2.6 "Declaration of Conformity"**.

## 4.2 Planning the Transmission of HART Protocols

HART stands for 'High Addressable Remote Transducer'. It is a digital communication protocol for the transfer of data to sensors, actuators and field devices. These devices can perform calculations, self-diagnoses and error reports.

RPI offers three possibilities to communicate with HART compatible field devices.

4.2.1 Direct Connection of a HART Programming Unit

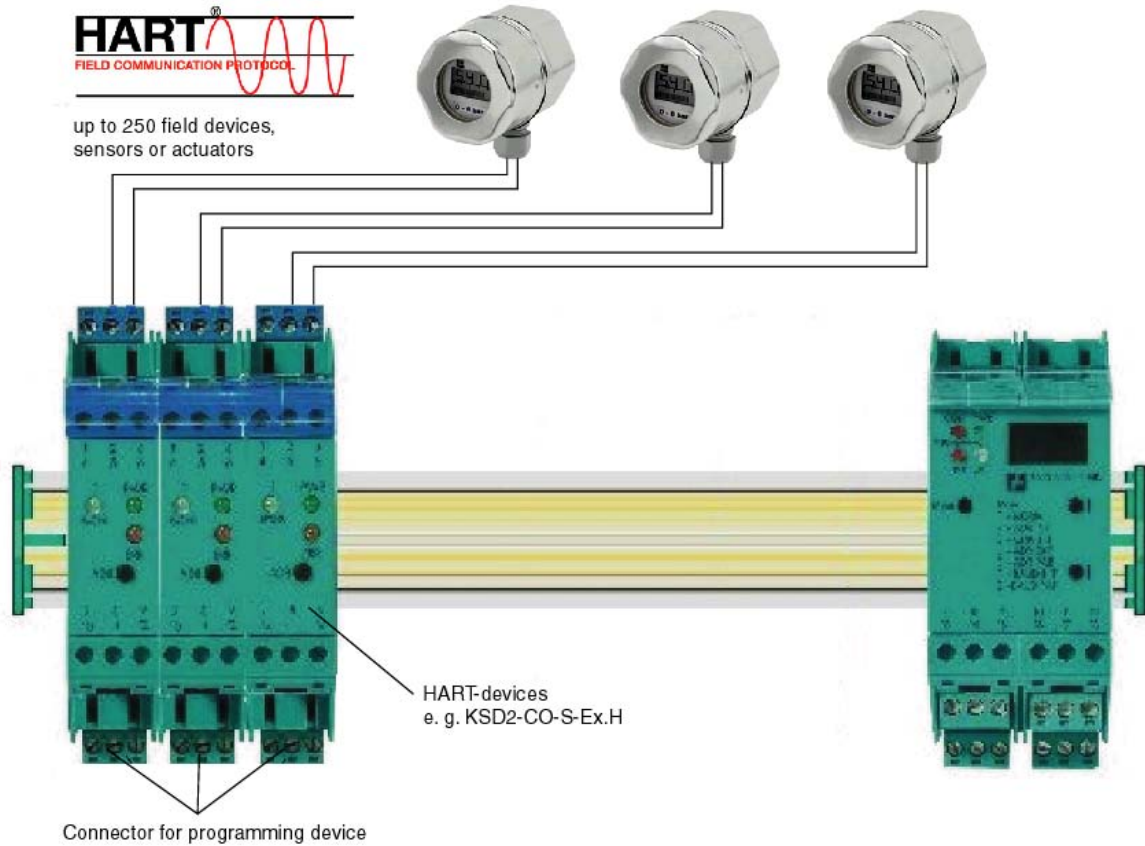



Figure 4.2: Programming Unit

The field devices should be connected to appropriate HART compatible RPI devices. The programming unit is connected to the non-Ex terminals of the RPI module. The protocol is transmitted via a hand-held device or a PC which is connected to the terminals of the RPI device, thus enabling direct communication with the field device.

 The HART and SMART compatible RPI devices KSD2-CI-S-Ex, KSD2-CI-S-Ex2.H, KSD2-CO-S-Ex and KSD2-CO-S-Ex2.H are equipped as standard with KF-STP-BU / KF-STP-GN terminal blocks (Chapter 4.10.5 'Accessories') for the connection of the HART handheld device.

4.2.2 Connection to the HART Multiplexer

HART multiplexer and HART Control module

Signals of several HART compatible field devices can be collected and transmitted simultaneously via the KFD2-HMM16 HART multiplexer. The HART signals of the field devices are transmitted to rail 4 of the Power Rail by means of HART compatible RPI devices. This rail is read out by the KSD2-HC HART Control module and the data is transferred to the HART multiplexer via a 14-core flat cable. The HART programming unit or a PC with an appropriate HART software can be connected to the HART multiplexer. Further details can be found in the product description of the KFD2-HMM-16 HART multiplexer master.

 The power feed modules KFD2-EB.RPI or KFD2-EB.R2A.RPI must be used.

For transmitting the protocol, the

**PACT<sup>ware</sup>**<sup>TM</sup> edition 2 software with integrated HART communication DTM, Comerstone or AMS can be used on a PC with an RS 485 interface.

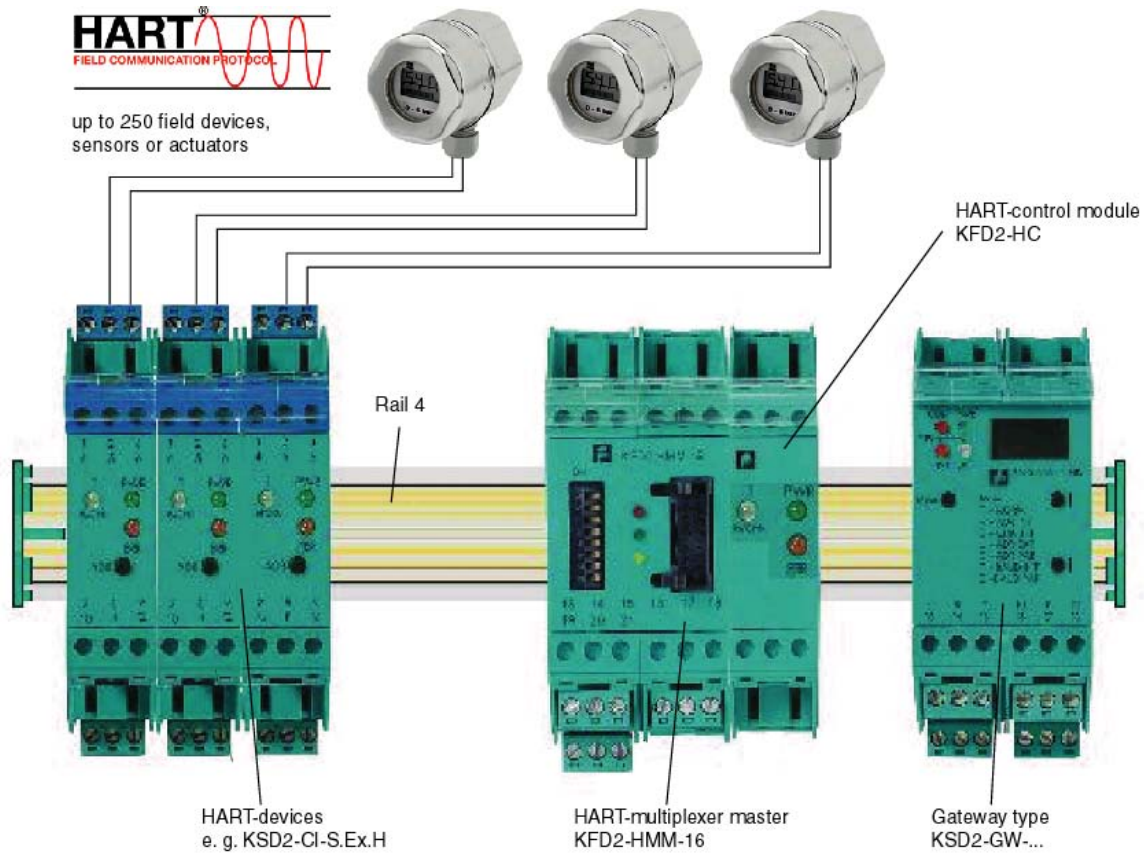

Figure 4.3: HART multiplexer master and HART Control module

### 4.2.3 HART Transmission via KSD2-GW2-PRO Gateway

The PROFIBUS DP V1 Gateway KSD2-GW2-PRO has an integrated HART multiplexer system that offers full functionality. The HART protocol is transmitted via:

- the service interface or
- the PROFIBUS DP V1

#### 4.2.3.1 Service Interface

The PC is connected to the KSD2-GW2-PRO Gateway via the RS 232 or RS 585 service interface. The protocol is transmitted to the gateway via the service interface and further on to the RPI devices via rail 4 of the Power Rail. HART compatible RPI modules modulate the data upon the 4 ... 20 mA signal.

#### 4.2.3.2 PROFIBUS

PROFIBUS DP V1 supports both acyclic data exchange and logon of the service interface as class 2 PROFIBUS master in conjunction with **PACT<sup>ware</sup>**<sup>TM</sup> edition 2 or with any other FDT compatible human machine interface. To enable the gateway and a PC to communicate via an external bus, it is necessary to integrate the communication DTM. This DTM allows the transfer of the HART protocol to the class 2 master via acyclic data exchange.

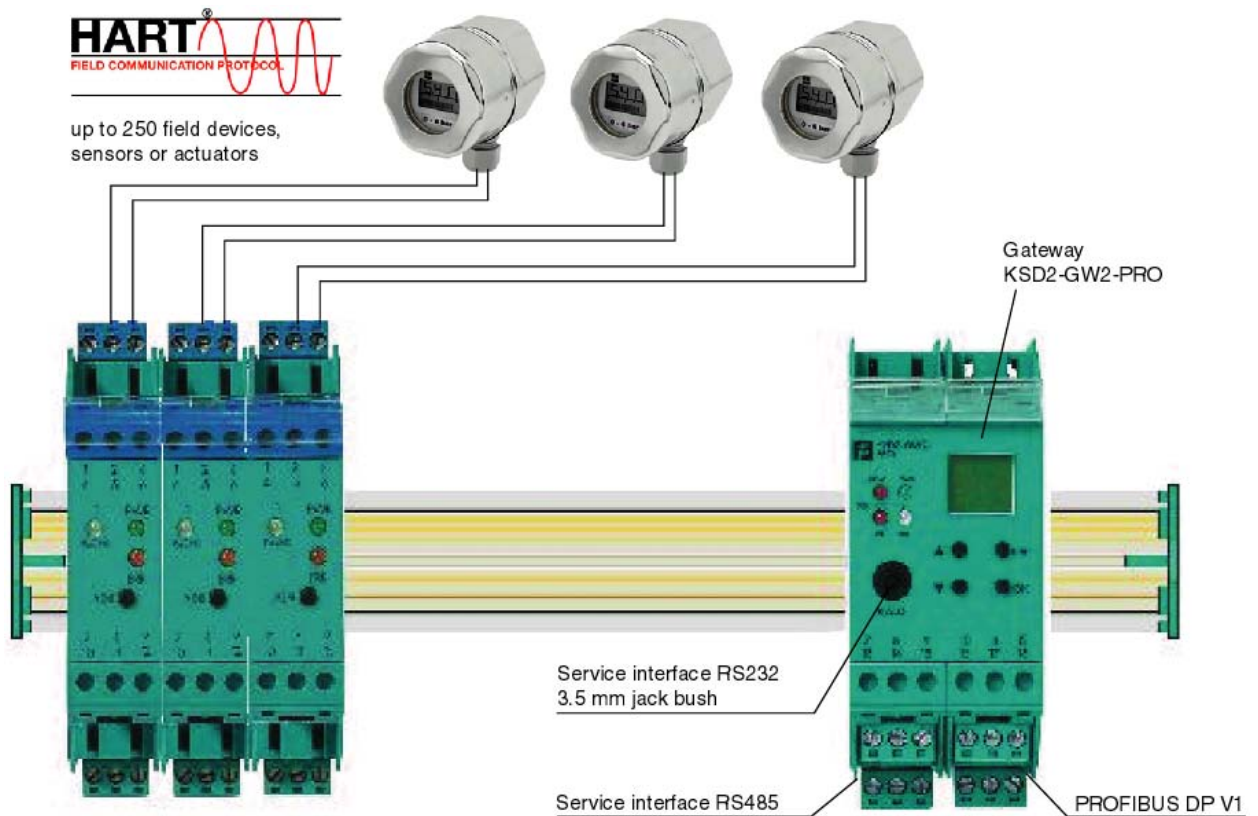

Figure 4.4: PROFIBUS Gateway KSD2-GW2-PRO

### 4.3 General Information on Communication and Diagnostic Procedures via the Internal RPI Bus

Communication via the internal bus is completely controlled through the RPI gateway. The gateway (master) communicates cyclically with every RPI station (slave).

Extensive diagnostic information can be retrieved for each individual device via the external bus system to the higher level host. For this purpose, we advise using the **PACT<sup>ware</sup>**™ edition 2 human machine interface.



Further information can be found in **Chapter 7 "Integration into the Higher-Level Bus System"**.

## 4.4 Calculating the RPI Cycle Time

The internal RPI bus has a constant transfer rate of 250 kbit/s. The maximum number of RPI bus stations is 125 devices or 500 channels. The gateway calculates the current cycle time depending on the stored configuration and communicates to every slave when (cycle time) it must answer. The cycle time is calculated in such a way that low-priority signals (acyclic services) can be transferred.

The cycle time for an RPI system is calculated from the following formula

$$T_{\text{UPDATE}} = [(53 n_{\text{modules}} + 38 n_{\text{analogue}} + 9n_{\text{binary}} + 53 n_{\text{output}})t_{\text{bit}} * 1.2] + 25 \text{ ms}$$

$t_{\text{bit}}$  4µs (250 kbit/s)

$n_{\text{modules}}$  Number of devices

$n_{\text{analogue}}$  Number of analogue channels

$n_{\text{binary}}$  Number of binary modules

$n_{\text{output}}$  Number of output modules (binary and analogue)

The cycle time is set to the lower integral multiple of 5 ms.

Exemplary calculation: an RPI system contains the following modules

10 KSD2-TI-Ex

20 KSD2-CI-S-Ex

10 KSD2-BO-Ex2

45 KSD2-BI-Ex4

Thus, the following parameters are obtained:

$n_{\text{modules}}$  Number of modules 85 modules

$n_{\text{analogue}}$  Number of analogue channels 30 channels

$n_{\text{binary}}$  Number of binary modules 55 modules

$n_{\text{output}}$  Number of output modules (binary and analogue) 10 modules

The cycle time is 55 ms.



Note

If the cycle time calculated for the RPI system is too long for your application, it can be also be reduced by dividing the RPI devices between 2 or more gateways.

## 4.5 Planning the Internal and External Communication

### 4.5.1 General Notes on Operating the Gateways

RPI gateways of type KSD2-GW-... and KSD2-GW2-... translate the protocols of the internal bus into the protocols of the external bus to the control system and vice-versa. Up to 125 RPI devices with a maximum of 500 channels can be connected to one gateway.



Note

The actual number of devices, which substantially depends on the transmitted data protocol, should be determined taking account of the bus specific conditions. Detailed information is given in **Chapter 7 "Integration into the Higher-Level Bus System"**.

The construction and the operation of the gateways using the controls on the front of the devices is identical for all types. Differences are referred to in the respective descriptions.

Construction of the devices

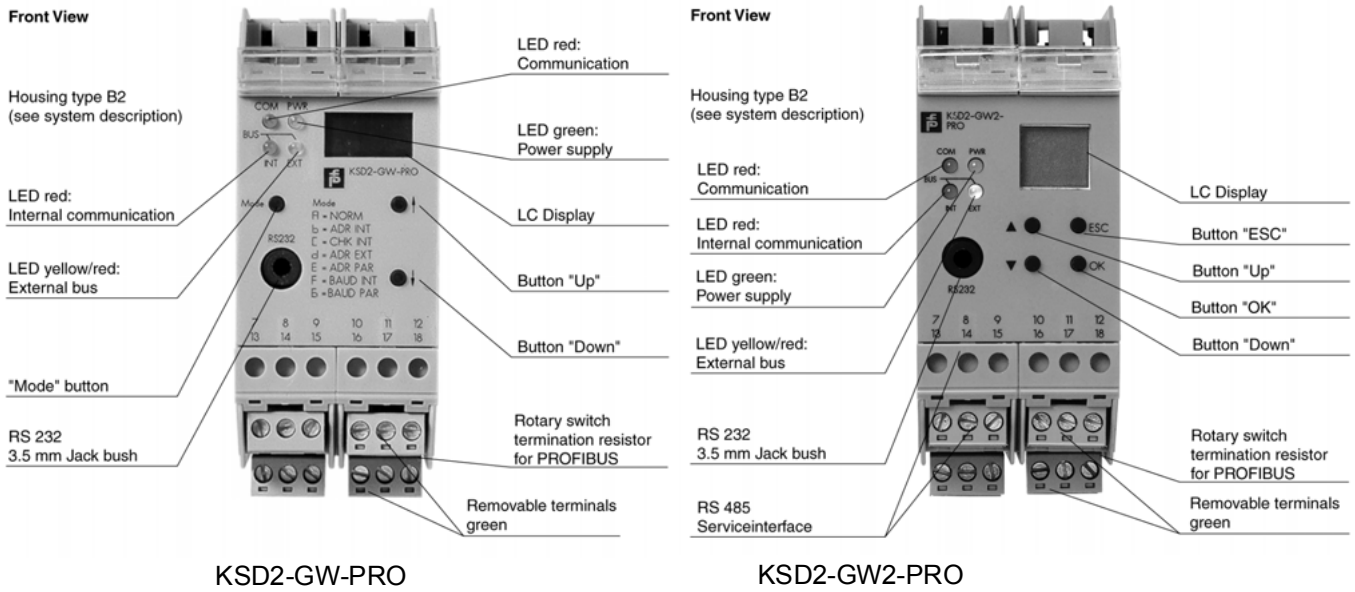

Figure 4.5: Front view of Gateway KSD2-GW-PRO and KSD2-GW2-PRO

More detailed information on the LEDs and the operation of the gateway can be obtained from **Chapter 5 "Configuring and Commissioning the RPI System"**.

The RPI system can be integrated into the following bus systems:

- PROFIBUS DP: KSD2-GW-PRO Gateway
- PROFIBUS DP V1: KSD2-GW2-PRO Gateway
- MODBUS RTU: KSD2-GW-MOD Gateway
- MODBUS Plus: KSD2-GW-MPL Gateway
- ControlNet: KSD2-GW-CN Gateway



Note

Please note that the gateways are available with RS232 or RS485 service interfaces, alternatively. See **Chapter 4.6 "Establishing the Service Functionality for the RPI System"** for more information.

**4.5.2 Redundancy Considerations**

The planning of your application should also be considered from the point of view of availability.

**4.5.2.1 Redundancy Internal Bus**

The internal bus on the Power Rail is automatically redundant. A switch-over to redundant communication is indicated by LED and LC displays on the gateway. It is also indicated in the diagnosis window of **FACTware™**. The diagnosis is transferred to the control system via the external bus. The user is informed of the switch-over on the internal redundant channel and has time to eliminate the fault whilst the communication is continuing.

**4.5.2.2 Gateway Redundancy**

The external bus can also be made redundant by using a second gateway on the same Power Rail. If a gateway fails, or if the external bus line is broken, the second redundant gateway automatically takes over the communication.

### 4.5.2.3 Redundancy External Bus

Two completely isolated external bus systems should be provided if the control system will permit it, in order to obtain even greater availability. For this purpose a second redundant gateway is used.

The bus cables for the two systems should be laid on different paths to the control system, thus avoiding the danger of both cables suffering damage simultaneously.

### 4.5.3 Determining the Number of RPI Gateways Required

Obtain the number of gateways required by consideration of bus specific conditions; see **Chapter 7 "Integration into the Higher-Level Bus System"**. One gateway can manage up to 125 RPI modules.

It should also be noted that twice the number of gateways are required if the gateway or the external bus system is required to be redundant.

## 4.6 Establishing the Service Functionality for the RPI System

### 4.6.1 Service Interface RS232

If the PC is only used for commissioning or adjusting the RPI system, the RS232 service interface with a jack is selected. Using the adapter, which is available as accessory, the RPI system can be configured and parameterized. A PC can also be connected directly to the terminals of an individual gateway.

### 4.6.2 Service Interface RS485

Up to 31 gateways can be networked and connected to a PC via the RS485 service interface. This allows a wired service level to be arranged, e.g.: for continuously monitoring the RPI systems.



Note

Gateway KSD2-GW2-PRO has both types of interfaces.

### 4.6.3 PROFIBUS

#### 4.6.3.1 PROFIBUS DP

The RPI system can be parameterized via PROFIBUS DP using the GSD-file 'PF0818p.GSD'. More information is provided in **Chapter 7.2.8 "GSD Files"**

#### 4.6.3.2 PROFIBUS DP V1

The application of PROFIBUS DP V1 will enable users to perform a parameter assignment (**PACT<sup>product</sup>**™ or HART) directly via the bus system. The PC functions as class 2 master and transfers the data acyclically to the gateway via the PROFIBUS. Further information can be found in **Chapter 7.2.2 "Gateway KSD-GW2-PRO"**.

## 4.7 Power Supply

All RPI modules are supplied with 24 V DC voltage via the Power Rail.

Power supply is provided via power feed modules which are mounted on the Power Rail too.

Suitable power supply units are available for the connection to 230 V AC. These supply the Power Rails with power via power feed modules. Alternatively, they can be mounted directly on the Power Rail.



Attention

Note that no power feed module should be operated under zero-load conditions, since this can lead to spurious tripping of the error signal (red LED 'ERR', relay output). At least one RPI device or one RPI gateway should always be connected to each power feed module.



Detailed information on power feed modules and power supply units can be obtained from the data sheets on our website [www.pepperl-fuchs.com](http://www.pepperl-fuchs.com) or from our catalogue. A list of the individual devices is provided in **Chapter 3.3 "Summary of RPI Modules Currently Available"**.

Note

#### 4.7.1 Construction of the Power Feed Module

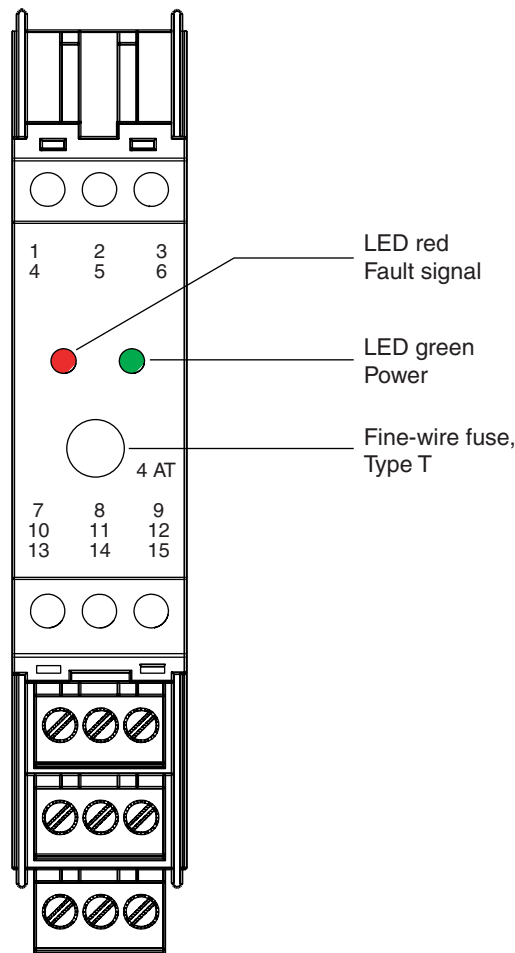

Figure 4.6: Front view of power feed module KFD2-EB.RPI and KFD2-EB.R2A.RPI

Dual designed power feed terminals enable the external supply voltage to be daisy-chained. The presence of the operating voltage is indicated by the green 'PWR' LED on the front panel of the device.

#### 4.7.2 Group Fusing on the Power Feed Module

The fuses on the front panel of the power feed modules protect the contacts for the Power Rail from overload and serve to provide group fusing for the RPI devices of each Power Rail segment.

In addition, each RPI device is internally fused.

A fault of the fuse of the power feed module is optically indicated on the red LED on the front panel. In addition, external indicators can be triggered via an internal relay. The relay operates as normally open contact, as standard; the direction of operation can be adjusted by means of a plug-in jumper. (see **Chapter 5.2.2 "Setting the Mode of Operation of the Relay"** )

### 4.7.3 Segmentation of the RPI System

The RPI devices of a gateway can be mounted at different, isolated Power Rail segments.

The internal bus and HART protocol transmission can be daisy-chained by connecting the individual terminals to the power feed modules KFD2-EB.RPI and KFD2-EB.R2A.RPI.

- Internal bus: Connection of terminals 12, 13 and 15
- HART protocol: Connection of terminals 14

### 4.7.4 Power Feed Modules for Redundant Power Supply

If required, the power supply can be given a redundant layout. As a rule, both the supply power systems or power supply units must be decoupled via diodes. The KFD2-EB.R2A.RPI power feed module incorporates decoupling diodes and can provide a supply of up to 2 A. The KFD2-EB.RPI power feed modules and the KFA6-STR.1.24.4 power supply unit provide a voltage of 24 V DC and a maximum of 4 A. However, they do not have a decoupling diode. When using external decoupling diodes, the KFD2-EB.RPI power feed module can also be used for a redundant power supply.

### 4.7.5 Setting up the Power Supply Balance for the RPI Devices Including the Gateways

To size the power supply required, calculate the maximum current consumption of the RPI modules. The data sheets contain data on the power consumption and the voltage supply range for each device. The maximum current consumption always occurs on the RPIs of minimum power supply, i.e. for a power supply of 20 V. In this way, the maximum current consumption must be calculated for each RPI device used, including that of the gateway(s) and other devices.



Note

We recommend to allow for a safety margin of 20 % in the power supply balance.

$$\text{Current} = \text{Power} / 20 \text{ V}$$



Attention

*The nominal current for the conductors integrated in the Power Rail is 4 A.  
This value must not be exceeded.*

The power supply modules provide a maximum of 4 A or 2 A on the versions for redundant power supply. The maximum current consumption of all RPI devices and gateways in a segment must not exceed the available output currents of the power feed modules.

If the current consumption of all devices is higher than the output current of the power feed module used, a number of Power Rail segments with one power supply module each, have to be installed. The RPI internal bus can be daisy-chained from the segment with the gateway to all other segments.

Exemplary calculation: An RPI system consists of the following modules

- 1 KSD2-GW-PRO
- 10 KSD2-TI-Ex
- 20 KSD2-CI-S-Ex
- 10 KSD2-BO-Ex2
- 45 KSD2-BI-Ex4

Detailed information on the power consumption and the current demand of the individual modules is provided in the data sheets. The data for the selected devices is summarized in the following table:

Type code	Device designation	Prefix	Power	I=P/20V	Number of	Sum P	Sum I
			[W]	[mA]	devices	[W]	[mA]
KSD2-GW-PRO	PROFIBUS Gateway	=	2.80	140	1	2.80	140
KSD2-TI-Ex	Temperature converter	<	1.50	75	10	15.00	750
KSD2-CI-S-Ex.H	Transmitter power supply	<	1.30	65	20	26.00	1300
KSD2-BO-Ex2.2	Solenoid driver	=	2.80	140	10	28.00	1400
KSD2-BI-Ex4	Isolated switch amplifier	=	1.00	50	45	45.00	2250
Sum:						116.80	5840

Table 4.4: Exemplary calculation: power consumption, current requirement

The RPI system has a power consumption of 116.80 W and a current demand of 5.84 A. Taking account of a safety margin of 20 %, the power supply must be 7.0 A.

- Simple arrangement of the power supply:  
two Power Rail segments with one 4 A power feed module each, 2 power feed modules in sum.
- Redundant design of the power supply:  
four Power Rail segments with two 2 A power feed modules each, and an integrated decoupling diode, 8 in sum
- Redundant design with external decoupling diodes:  
two Power Rail segments with two 4 A power feed modules each, 4 in sum  
In this case, it should be ensured that the current consumption for each Power Rail segment, cannot exceed 4 A!

#### 4.7.6 Determining the Power Supply Segments

As shown in the previous chapter, the power supply balance depending on the redundancy concept results in different numbers of Power Rail segments per gateway.

The number of segments is only limited by the maximum permissible length of the internal bus line. The latter is 8 m and can be obtained by adding the lengths of the segments and the lengths of the wiring between the power feed modules. Therefore, in constructing the segments and the RPI modules, it should be ensured that the separation of the power supply modules is as small as possible.

If a number of power supply segments are required on one mounting rail, then the Power Rail sections are not connected with each other at the segment boundaries, but are separated from each other by a distance of at least 1 mm.

One possibility of arranging the mounting rails and connecting the power supply segments is represented in Figure 4.16: on page 61 of this system manual.



Note

In forming the segments without a redundant supply, it must be considered, that if the fuse operates, all interfaces of the segment in question fail if the system has no redundancy. It must be ensured, that in this case, a dangerous situation does not arise in the system.

#### 4.7.7 Establishing the Type and Number of the Power Supply Modules

When planning a redundant power supply the following should be considered:

- In the event of the failure of a power supply module, the complete segment must be supplied via the intact power supply module. The power supply modules should be laid out accordingly.
- Furthermore, it must not be the case, that in the event of failure, a flow of power from the intact to the defective power supply unit takes place. This flow of energy is prevented by decoupled diodes.

The decoupled diodes required must be either:

- in the power supply units that are used,
- sited externally in the power supply circuit,
- or in the KFD2-EB.R2A.RPI power supply module, two units of which are mounted on each Power Rail segment.

The KFD2-EB2.RPI power feed module is used:

- when the supply has no redundancy
- when the supply has a redundancy and external decoupling diodes are used.



Note

The current for a Power Rail is a maximum of 4 A.

### 4.7.8 Establishing the Type and Number of Power Supply Units, where Required

The RPI operates with a voltage supply in the 20 to 30 V DC range and requires no additional power supply units. If, however, it is required to operate with a voltage outside this range, the KFA6-STR.1.24.4 power supply unit will have to be used. (input 90 to 265 V AC, output 24 V DC).

If a 24 V DC power supply is available in the control cabinet or within reach, power supply modules should be used. In this case, you should proceed as follows:

- set up the power supply balance for your RPI system
- determine the number of power feed modules that are required, as shown in Chapter 4.7.5 .

If no 24 V DC supply is available, the KFA6-STR.1.24.4 power supply unit should be used.



Note

When using the KFA6-STR.1.24.4 power supply unit, a redundancy of the power supply is not possible.

## 4.8 Accessories

### 4.8.1 Power Rail

Power Rail is a DIN rail system, in which five conductors are integrated, providing for power supply and the internal bus connection.

Power Rail is available in 2 different versions:

- UPR-05 with integrated mounting rail and variable device position
- PR-05 as component insert for standard top hat rails; device position predefined by grids.



Attention

The nominal current for the conductors integrated in the Power Rail is 4 A. This current must not be exceeded!

Only the UPR-05 Power Rail should be used for rewiring.

#### 4.8.1.1 Power Rail UPR-05

Delivery package (see Figure Figure 4.7.):

- Aluminium mounting rail, 15 mm deep, 2 m long
- Power Rail insert with 5 conductors, 2 m long, can simply be cut to length.
- Cover providing mechanical and electrical protection of free plug-in stations.
- 2 End caps

The UPR-05 has no mounting grid. Thus, components of any width can be mounted on this rail. This is to ensure that the rail may be cut to any length and that the devices of future generations can also be mounted.

## 4.8.1.2 Mounting the UPR-05 Power Rail

You should proceed as follows:

- Cut the mounting rail including the Power Rail insert to arbitrary length using a hack saw.
- Remove the Power Rail insert by means of the end caps.
- Screw or rivet the mounting rail onto a mounting base. M4 screws and DIN 125 washers or 4 mm rivets are required for this purpose.
- Snap the Power Rail insert into the mounting rail.
- Replace the end caps.
- In the case of vertical mounting of the mounting rail, TS 35 Type 12 end clamps should be screwed to the rail at the required intervals, in order to provide mechanical protection of the RPI devices.
- Having mounted all RPI devices, the cover is cut according to the gaps between the modules. The cover must be snapped in place in order to provide protection against accidental contact (IP 20).

## 4.8.1.3 Accessories for Power Rail UPR-05

The following accessories are available:

- UPR-E end caps (see Figure Figure 4.7:)
- TS35 type 12 end clamps(see Figure Figure 4.8:) providing mechanical protection of the RPI modules, when they are installed on a vertically fixed mounting rail. At least one clamp per vertical mounting rail is required for this purpose.

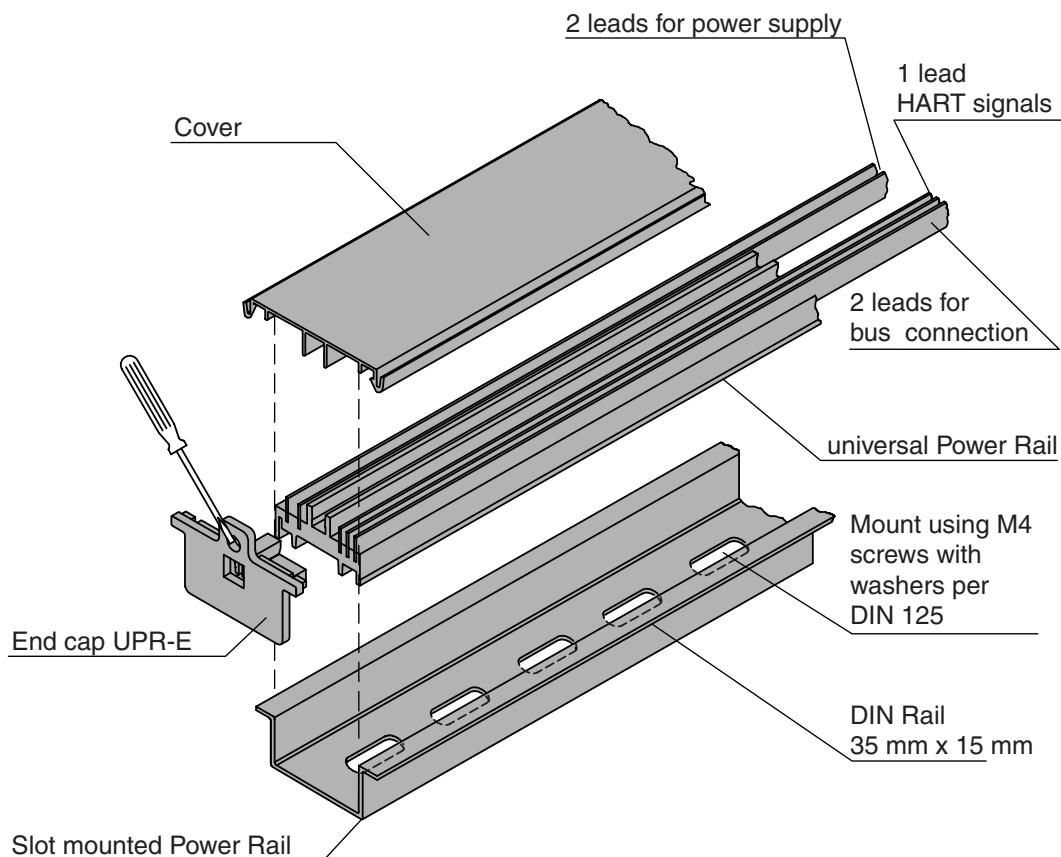

Figure 4.7: Assembly of the UPR-05 Power Rail

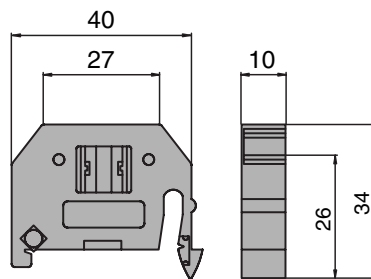

Figure 4.8: End clamp TS35 Type 12

#### 4.8.1.4 Power Rail PR-05

Delivery package (see Figure Figure 4.9):

- Insert component for standard top hat rails to DIN EN 50 022, length 500 mm

#### 4.8.1.5 Mounting the Power Rail PR-05

You should proceed as follows:

- Shorten: the Power Rail can be shortened, as required, at intervals of 40 mm, at the points marked with indents. It should be noted, that there must be an end contact on the shortened component, if shortened Power Rail sections are to be fixed together.
- Extend: The Power Rails are a standard length of 500 mm, however, they can be extended by joining them to another rail section, using a VE-PR connection fitting. The two ends of the PR-05 are different. A right hand and a left hand end contact should be used for the respective ends to allow the VE-PR components to be mounted.
- Snap the end caps on the free ends of the Power Rail sections.
- Insert the Power Rail sections into the top hat DIN rail. If a number of power supply circuits are to be installed on one mounting rail (segmentation of the power supply), a separation of at least 1 mm should exist between the individual segments, so that the end pieces of the Power Rail do not make contact with the neighbouring segment.
- Join the individual Power Rail sections using a VE-PR connection fitting (see Figure Figure 4.9:). A right hand and a left hand end contact should be used for the respective ends to allow the VE-PR components to be mounted. RPI devices can also be mounted over the connecting components, so that no space is lost.
- Having inserted the Power Rail into the top hat DIN rail, the devices of the RPI system are simply snapped onto the rail.

## 4.8.1.6 Accessories for Power Rail PR-05

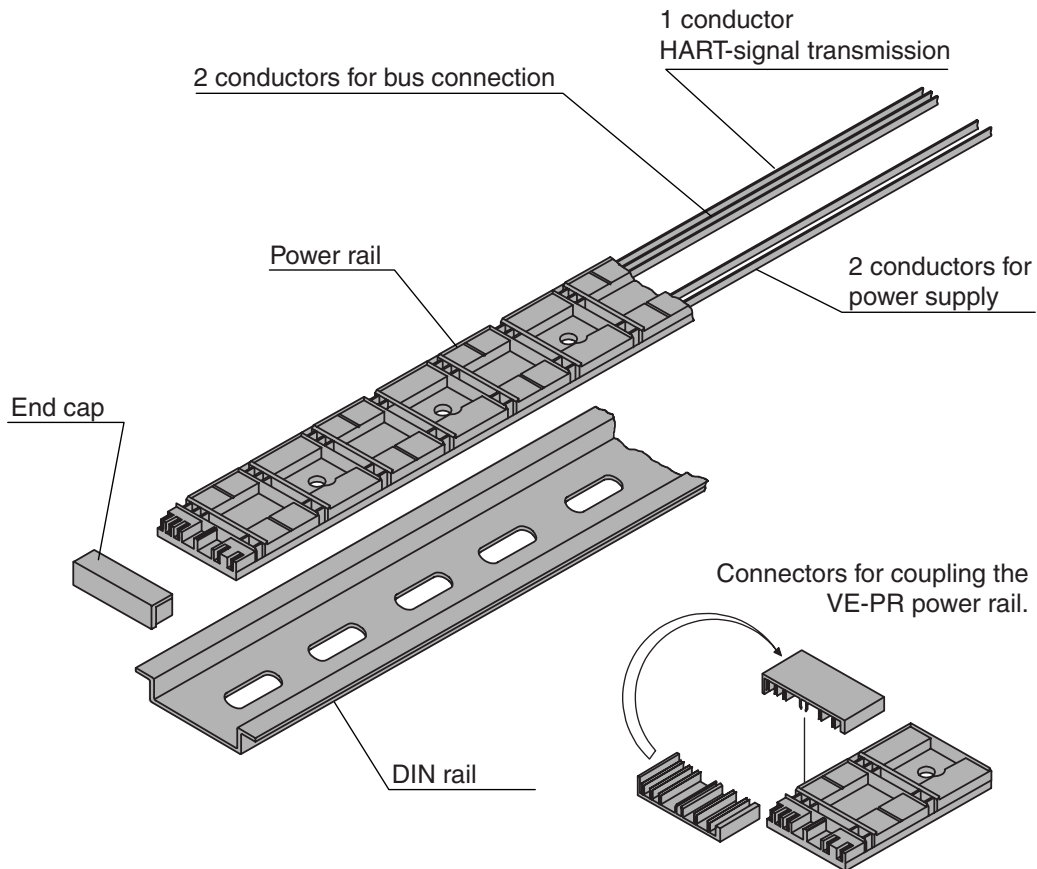

Figure 4.9: Assembly of the PR-05 Power Rail

## 4.8.1.7 Combining the RPI System with Interface Modules from other Systems

If interface functions are required in your application, which are not available in the modular RPI system, modules from other systems which can be rail-mounted can also be installed. Thus a unified mounting technique is achieved.

- Pepperl+Fuchs K-System: In the case of a mixed application of K-System modules and RPI modules, the K-System modules are likewise supplied via the Power Rail. But they are, of course, not connected to the RPI internal bus. A transmission of a combined fault indication of the K-System via the RPI power feed modules is not possible.
- Other systems: The interface modules can be mounted mechanically onto the mounting rail. Power supply and signal transmission must be connected separately from the RPI system.



A simultaneous transmission of combined fault indications and the HART protocol via the Power Rail is not possible!

### 4.8.2 KF Profile with Integrated Cable Ducts

The KF Profile is an aluminium extruded section, which provides a space-saving installation of the RPI system.

The profile contains three main components (see Figure Figure 4.10):

- Large cable duct for routing the cables from the field side.
- Small cable duct for the cables of the power supply and of the external bus to the DCS or PLC.
- Integrated mounting rail for installing the RPI modules above the cable ducts. The PR-05 Power Rail is inserted into this mounting rail.

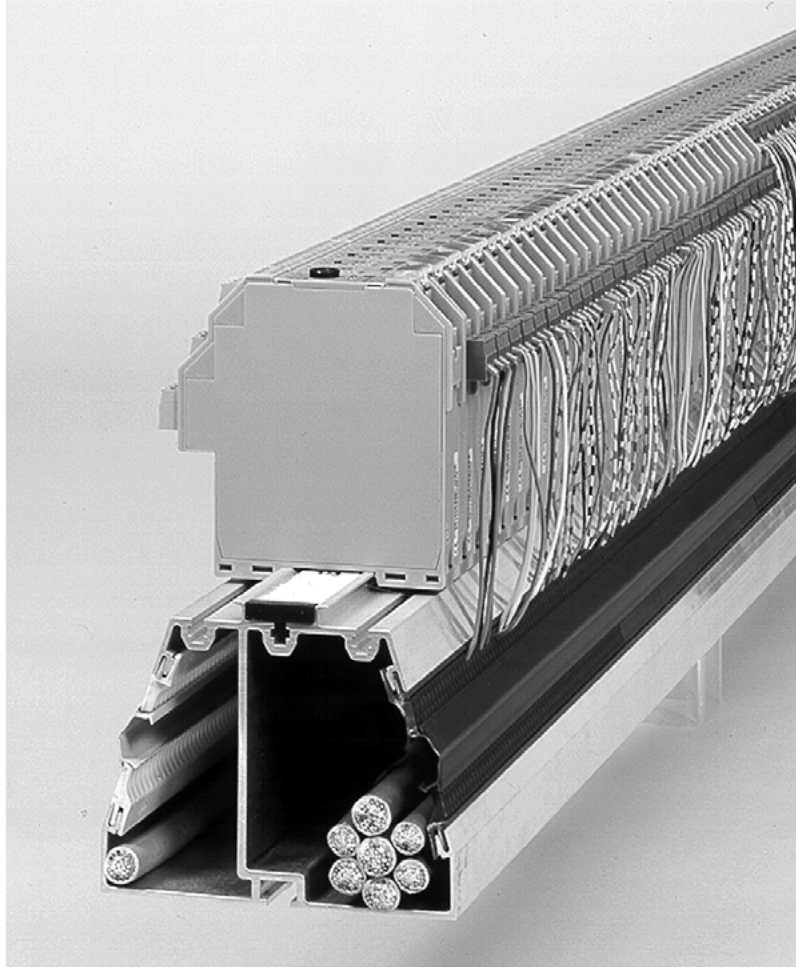

Figure 4.10:KF Profile

The KF Profile is available including the PR-05 Power Rail. It will accept up to 90 RPI modules over a length of 1.8 m, in a space-saving installation, with simple provision for wiring.

In addition, the KF Profile is available with a lateral shunting bridge.

The KF Profile has the following advantages:

- Very high packing density in the control cabinet installation, since the cable ducts are integrated in the mounting profile.
- A saving in installation costs, since the cable ducts are integral and do not need to be mounted separately. In addition, Pepperl+Fuchs offers preconfigured cables (see "DIN Rail Housing" catalogue).
- Since on the Remote Process Interface the wiring to the control system is almost completely eliminated, the separation between the non-Ex connections of two installation lines can be very small, thus further increasing the compactness of the installation in the control cabinet.

4.8.3 Human Machine Interface PACTware™ Edition 2

PACTware™ (Process Automation Configuration Tool) configuration tool with FDT interface (Field Device Tool) independent of the manufacturer and the fieldbus.

- Based on FDT technology
- Device Type Managers (DTMs) available for all Pepperl+Fuchs devices and systems
- Commissioning, configuration and parameter assignment independent of the process control system
- Communication DTMs available for serial interface and field bus systems
- Maintenance, diagnostics and fault handling
- Suited for PCs running Windows 98, Windows NT, Windows 2000 and Windows XP
- In accordance with VDI/VDE 2187



Figure 4.11: PACTware™ - the human machine interface for be Remote Process Interface

**Hardware requirements**

PC with Pentium II 200\_MHz processor; 64 MB RAM minimum

**Operating system**

Windows 98, Windows NT 4.0 Service Pack 4 (or later), Windows 2000 and Windows XP.

**Languages**

German, English and French can be set

**Licensing**

The packages point to point Interface Technology, point to bus Remote I/O, point to bus HART and Level are available separately or together as download (<http://www.pepperl-fuchs.com/pa/accessories/pactware/main.html>) in a BASIC version without the functions Print and Save. The BASIC version can also be obtained from Pepperl+Fuchs as CD-ROM. A license number is required to enable the functions Print and Save . Licenses with the functionality stated in the table (page 138) can be ordered from Pepperl+Fuchs.

**Schematic representation of the system configuration**

Graphic representation of all communication and device DTMs in a tree structure. Colour coding to identify affected units and the simulation mode during online operation. A number of windows can be open at the same time. It is therefore possible, to view the set device parameters, monitor the measurement value, and display the device diagnosis simultaneously.

**System planning, project processing**

Generating a configuration by means of a graphical project processing menu. Editing of available projects. Measuring point descriptions for each channel. Offline configuration, storing project data on a hard-disk drive or a disk. Automatic comparison of the project planning to the available system during connection set-up on device level and parameter level.

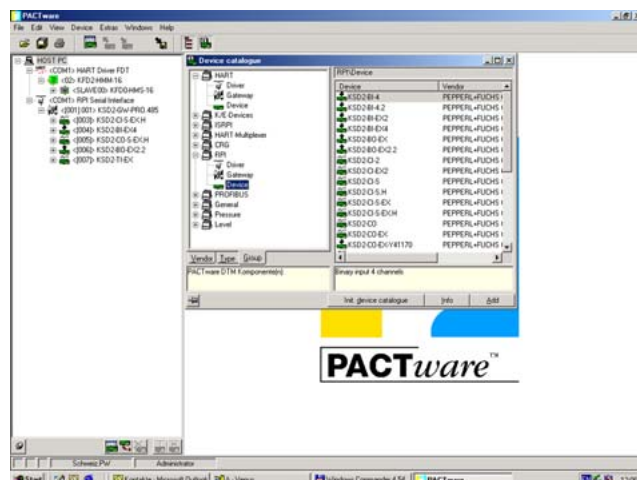

Date of issue 05/27/03

PACTware BASIC version	
Type	Functionality
PW2-BASIC	all available DTMs for Pepperl+Fuchs K and E-Devices, HART multiplexers, Remote I/O systems RPI and IS-RPI and Level Control devices. Restricted functionality: <u>no</u> printing, <u>no</u> saving
Licenses	
PW2-P.LEVEL	Professional Level license for all available DTMs for Pepperl+Fuchs Level Control devices
PW2-P.RIO100	Professional RIO100 license for the connection of 100 measuring circuits to Pepperl+Fuchs Remote I/O systems RPI and IS-RPI including HART multiplexers.
PW2-P.RIO500	Professional RIO500 license for the connection of 500 measuring circuits to Pepperl+Fuchs Remote I/O systems RPI and IS-RPI including HART multiplexer.
PW2-ENTERPRISE	Enterprise license for all available DTMs for Pepperl+Fuchs K and E devices, HART multiplexers, Remote I/O systems RPI and IS-RPI and Level Control devices. Unlimited number of devices, measuring circuits and systems in a project can be operated.

### Parameter assignment of devices

Access to all device parameters via serial interface, via HART communication or by means of acyclic field bus communication.



### Measured value indication

Online monitoring of random process variables

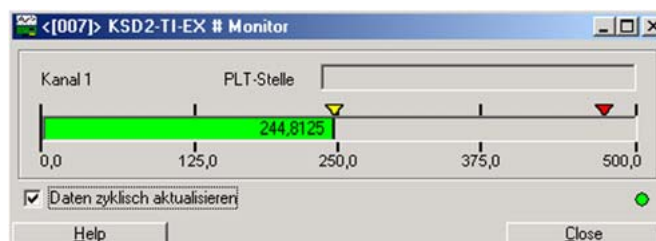

**Trend display**

Trends of random process variables are displayed

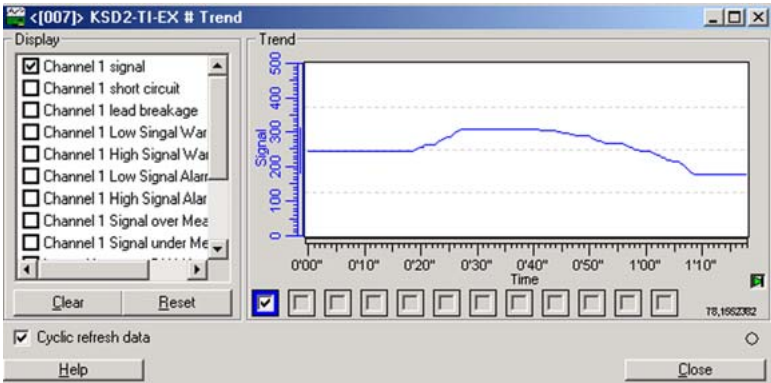

**Simulation**

Simulation of all measured variables and diagnostic data

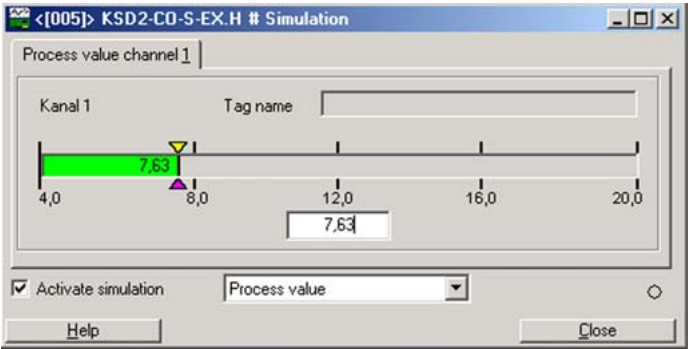

**Diagnosis**

All diagnostic information is accessible via PACTware™



## 4.8.4 Interface adapter for RS 232 and RS 485

Connection of a PC or Notebook to the RPI service interface using the **PACT<sub>ware</sub>**<sup>TM</sup> human machine interface is achieved by means of the K-ADP2 or K-ADP4 interface adapters, available as optional accessories.

- K-ADP2 adapter: for gateways with an RS 232 service interface and a jack plug
- K-ADP4 adapter: for gateways with an RS 485 service interface and a terminal

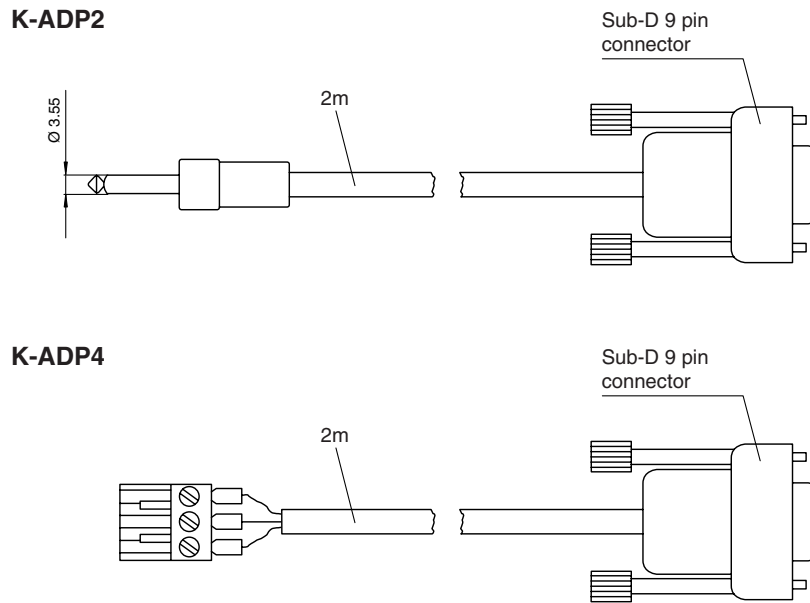

Figure 4.12:K-ADP2 and K-ADP4 Interface adapters

## 4.8.5 Accessories for RPI Devices

Usually no special accessories are required for the RPI system devices. All devices are supplied with removable terminal blocks. However, the following components can be ordered separately:

### Terminal block with test sockets for HART/SMART hand-held terminals

Removable terminal block with integrated test sockets for 2.3 mm standard test connectors of HART or SMART hand-held terminals.

Order codes:                      **KF-STP-BU (blue)**                      Ex side  
    **KF-STP-GN (green)**                      non-Ex side

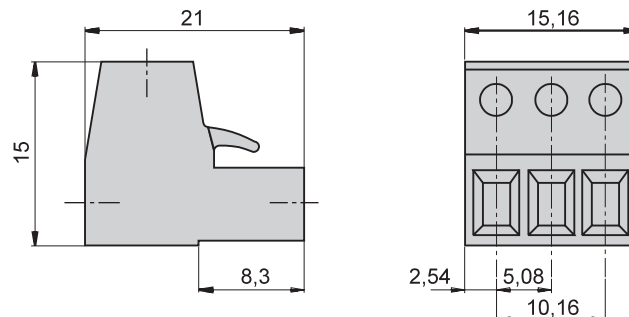

Figure 4.13:Terminal block KF-STP-BU / KF-STP-GN



Note

The HART and SMART-compatible RPI devices KSD2-CI-S-Ex, KSD2-CI-S-Ex2.H, KSD2-CO-S-Ex and KSD2-CO-S-Ex2.H are equipped as standard with terminal block KF-STP-BU / KF-STP-GN .

## Terminal block with cold junction compensation

Removable terminal block with integrated temperature sensors for cold junction compensation for the connection of thermocouples to the KSD2-TI-Ex universal temperature converter.

Order codes:

**K-CJC-BU:** blueEx side

**K-CJC-GN:** greennon-Ex side

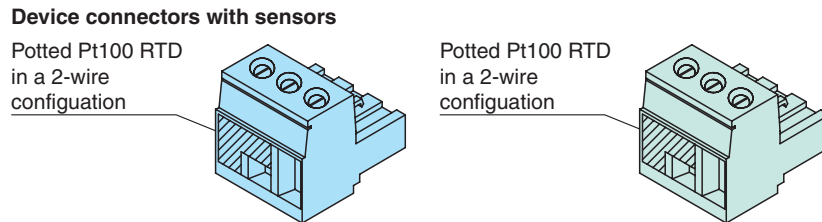

Figure 4.14:K-CJC Terminal block with cold junction compensation

## Dummy housing

The KFD0-LGH dummy housing is a module used for laying cables.

An RPI system can be completely prewired without mounting the actual module. The clarity of the installation and compactness in the control cabinet are considerably enhanced by this device. Order code: **KFD0-LGH**

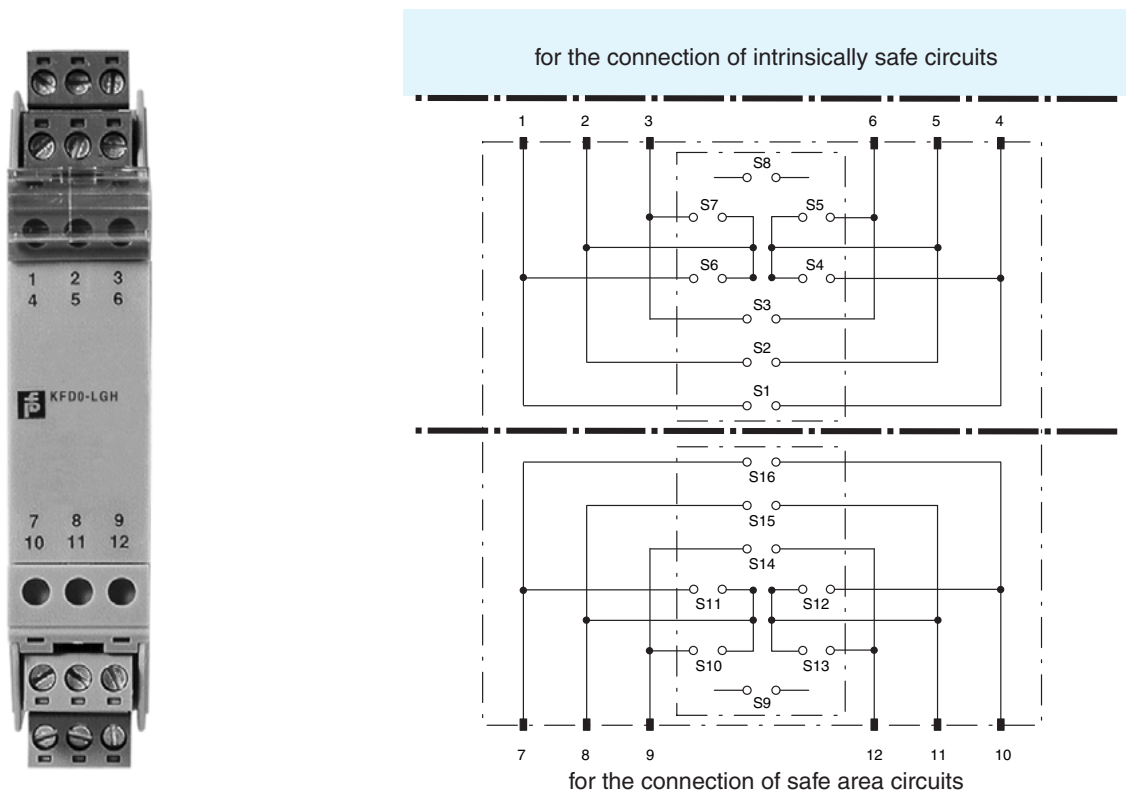

Figure 4.15:KFD0-LGH Dummy module

Various wiring layouts are possible by using soldering jumpers and optional DIP switches. Intrinsically safe circuits up to 40 V can be connected to terminals 1, 2 and 3 or 4, 5 and 6. Non-intrinsically safe circuits up to 50 V can be connected to terminals 7, 8 and 9 or 10, 11 and 12.



Note

Terminals 1 to 6 are to be considered connected.

## 4.9 Determining the Types and Numbers of Power Rails to be Used

Having determined the types of Power Rails to be used

- PR-05, length of the rail 500 mm or
- UPR-05, length of the rail 2000 mm

the number of rails required can be calculated based on the number of RPI modules and power supply segments determined in the previous chapters.

It must be noted, that approx. 1 mm or more separation is required between the Power Rails if two power supply segments are to be built on a common mounting rail.

The following calculation determines the space required for the RPI system for both simple and redundant design.

Exemplary calculation: The RPI-System contains the following modules

- 1 KSD2-GW-PRO (2 modules for gateway redundancy)
- 10 KSD2-TI-Ex
- 20 KSD2-CI-S-Ex
- 10 KSD2-BO-Ex2
- 45 KSD2-BI-Ex4
- 2 power feed modules for simple power supply
- 8 power feed modules for redundant power supply

Type code	Device designation	Overall length	Number devices	Sum simple	Number devices	Sum redundant
		(mm)	simple	(mm)	redundant	(mm)
KSD2-GW-PRO	PROFIBUS Gateway	40	1	40	2	80
KSD2-TI-Ex	Temperature converter	20	10	200	10	200
KSD2-CI-S-Ex.H	Transmitter power supply	20	20	400	20	400
KSD2-BO-Ex2.2	Solenoid driver	20	10	200	10	200
KSD2-BI-Ex4	Isolated switch amplifier	20	45	900	45	900
KFD2-EB.RPI	4 A Power feed module, simple	20	2	40	0	0
KFD2-EB.R2A.RPI	2 A Power feed module, redundant	20	0	0	8	160
Sum:				<b>1,780</b>		<b>1,940</b>

Determining the number of Power Rails:

1. For a non-redundant system: overall length 1,780 mm
  - Power Rail UPR-05 (length 2,000 mm): 1x
  - KF Profile (length 1,800 mm): 1x
  - Power Rail PR-05 (length 500 mm): 4x, 2 rails each, fitted with VE-PR connection element
  - Assembly in typical control cabinet in 3 layers:
    - Power Rails as stated above, but with 3 power feed modules
2. For a redundant system: overall length 1,940 mm
  - Power Rail UPR-05 (length 2,000 mm): 1x
  - KF Profile (length 1,800 mm) 2x
  - Power Rail PR-05 (length 500 mm): 4x

#### 4.10 Arrangement of the Power Rail Segments in a Control Cabinet

The mounting rails with integrated Power Rails can be installed horizontally or vertically in the control cabinet. A power supply module is required for each rail segment. In the case of vertical mounting of the rails, the length of the rail is in general greater than for a horizontal installation. So that usually, less power supply modules are required.



When the RPI is used, marshalling is not necessary, since this procedure is followed by addressing the RPI internal bus.

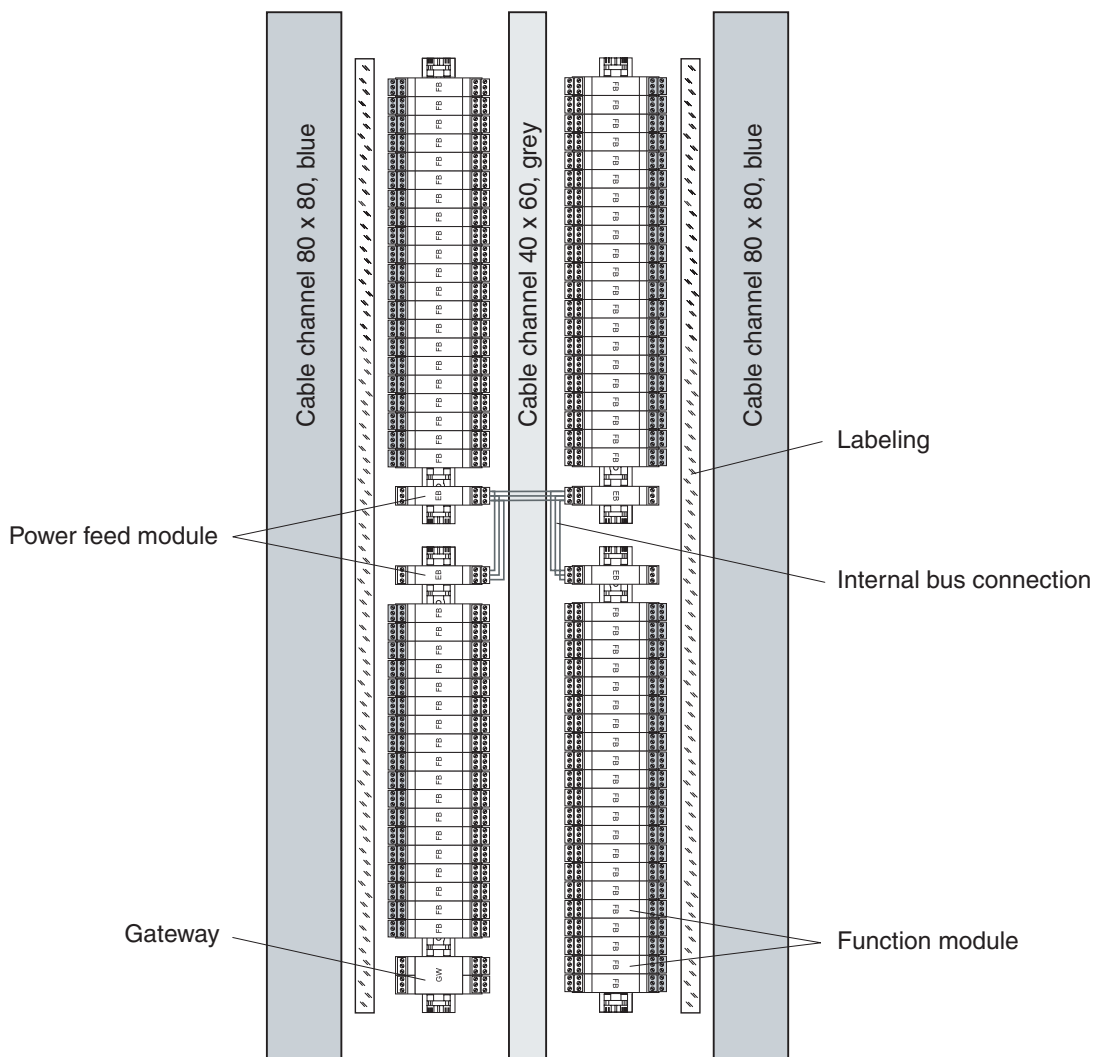

Figure 4.16: Example of the arrangement of an RPI system

The internal bus connection shown in this figure is achieved by connecting terminals 12, 13 and 15 of the power supply modules. Terminals 13 and 15 make a connection to the Power Rail internal transmission line. Terminal 12 corresponds to the earth potential of the supply line. This is necessary, since then the internal redundancy thereby ensures that the signal from the voltage difference of a transmission line (terminal 13 or 15) and the earth potential (terminal 12) can be won back.

When adopting a horizontal assembly, it can be useful when an assembly string is identical with a segment. Every power supply module and hence every device on the related segment is protected by a fuse.

## 4.11 Installation

### 4.11.1 General Information on Device Connection



Connection of the intrinsically safe and non-intrinsically safe circuits is undertaken with due consideration of all locally applicable regulations, directives and standards governing the hazardous area.

The installation and operation of devices with intrinsically safe circuits must be undertaken with due regard for the certificates of conformity and the applicable regulations relating to construction and installation (DIN EN 50020, DIN VDE 0165).

The connection of a module on the Ex side is made on the removable blue terminal block via self-opening screw terminals - max. core cross section 1 x 2.5 mm<sup>2</sup> for rigid cable or 2 x 1.5 mm<sup>2</sup> for flexible cable with plastic wire end ferrule.

The connection of a module on the non-Ex side is made on the removable green terminal block via self-opening screw terminals - max. core cross-section 1 x 2.5 mm<sup>2</sup> for rigid cable or 2 x 1.5 mm<sup>2</sup> for flexible cable with plastic wire end ferrule.

It should be noted that appropriate plug connectors are available on the market, which can be used to replace the screw terminals. These plug connectors are fitted by crimping onto the wiring.



On connecting the supply voltage to the power supply module, all RPI devices mounted on the Power Rail are immediately supplied with power.

### 4.11.2 EMC, Screening and Earthing

The screening of cables provides protection against electromagnetic interference. The screening of the bus line must be undertaken with due regard for the recommendations of the organizations for PROFIBUS, MODBUS and ControlNet.

When screening the signal cables between the RPI modules and the field devices, the screen of the cable must be located at the earthing connections of the field devices.



If bus cables with a double screen are used, e.g. wire braiding and metallic foil, both screens must be connected together at the cable ends with a low-resistance connection when preparing the cable.

Power supply cables are a source of much interference radiation, e.g. the starting current of a three-phase motor. For this reason, parallel cable routing of supply cables and data/signal cables should be avoided, especially within the same ducting.

**4.11.3 Preparing the Wiring**

Please refer to **Chapter 4.11.1 "General Information on Device Connection"**

Ex side:

On the Ex side the cables are laid from the field devices to the corresponding blue terminals of the RPI device. Marshalling of the field cables is not necessary; it is carried out by means of RPI internal addressing.

Non-Ex side:

- On the non-Ex side it is merely necessary to provide the bus cable between the gateways and the control system. If there are a number of RPI systems, the bus line runs from gateway to gateway, i.e. only one separate cable has to be laid to the control system. Only in the case of a redundant design with two gateways per RPI system are two mutually isolated bus systems required to the control system.
- Providing the voltage supply cables for the power feed modules or power supply units.



When using 90 .... 240 V power supply units, the power cables and the signal or bus lines should not be laid in the same cable duct.

- Possibly, another cable string for the service level must be laid. This is the fixed wiring between the service interface of the gateways and the Engineering PC. It can be used for HART communication, for a separate diagnosis of the RPI system, or for a software engineering tool.
- The HART protocol transmission via the HART multiplexer possibly requires an additional cable.

Due to the fact that only a few cables are needed in the non-Ex area, the space required in the control cabinet will be considerably reduced.

**4.11.4 Installing the Devices**

Snap the power supply modules, gateways and RPI devices onto the mounting rail/Power Rail assembly. Arrange the devices to suit the field cables. The order of assembly on the Power Rail is not a significant factor from the standpoint of the internal bus system.

When snapping the devices on the rail, they should not be tipped at an angle, but pressed on to the mounting rail in a vertical attitude.

If the UPR-05 is being used, it must be remembered that the cover must be fitted to provide protection against accidental contact.

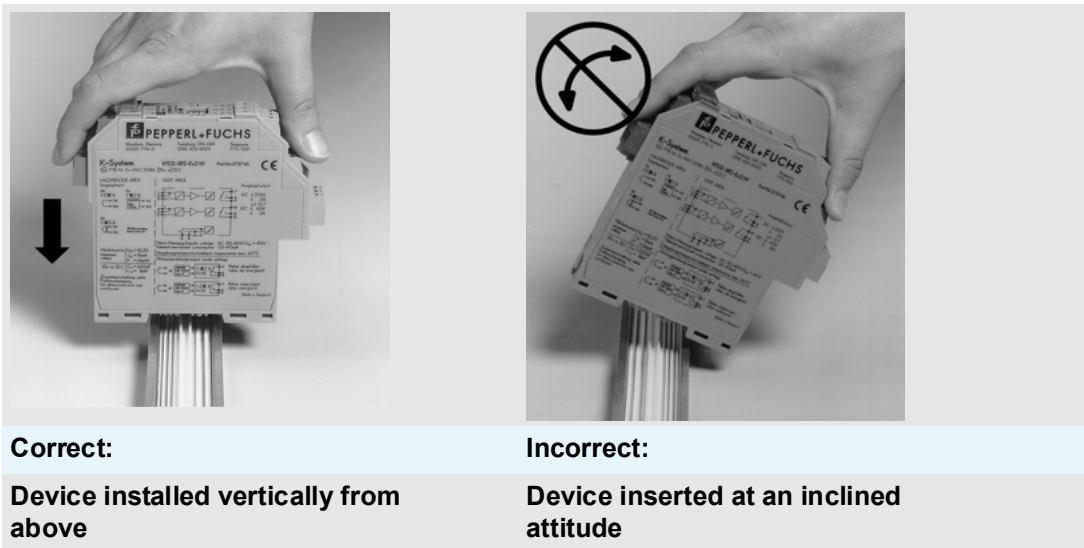

Figure 4.17: Installing the RPI devices

Date of issue 05/27/03

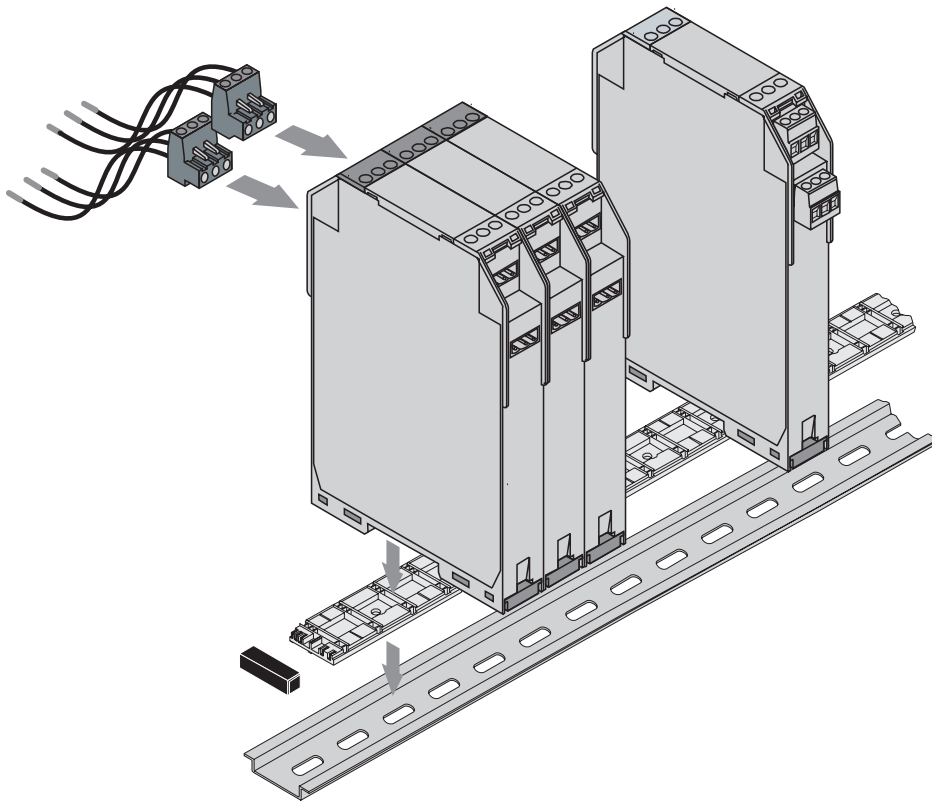

Figure 4.18: Installation of the RPI modules



Note

When installing the modules, please consider the specifications stated in the previous chapters, regarding the power supply segments and the internal RPI bus stations.

#### 4.11.5 Connection to the Control System

The connection of signal lines from the field devices is completely eliminated, since the RPI system converts the field signals into standard bus signals. Only the bus line from the RPI Gateway has to be connected. No input/output units are required on the control system or PLC. An appropriate bus-master assembly must be provided in their place. The manufacturer will provide information on which bus system is appropriate and available for a given control system.

#### 4.11.6 Connecting the Power Cables and Signal Cables



Attention

Operation of the equipment under power and the connection to the power supply must only be carried out by appropriately trained personnel.

Prior to connecting the RPI system, ascertain that the power supply voltage is 24 V DC in accordance with the RPI module data sheet.

When installing and operating devices with intrinsically safe circuits, the certificates of conformity and the relevant assembly and installation instructions (DIN EN 50020, DIN VDE 0165) should be observed.

The electrical connection of the cables of RPI system devices is made by means of self-opening screw terminals in the removable terminal blocks, max. core cross section 1 x 2.5 mm<sup>2</sup>.

Connect the wiring as described in the connection diagram and the terminal allocation list for the individual devices:

- The supply voltage is only connected to the power feed modules.
- The external bus system is connected to the gateway.
- An available service level is connected to the service interface of the gateway.
- In the case of HART communication, when using a HART multiplexer, the latter must be connected accordingly.
- Connection to the RPI internal bus and to the supply voltage is achieved automatically when the devices are snapped onto the mounting rail/Power Rail assembly.
- The intrinsically safe signal circuits are connected to the blue terminals of the RPI devices in accordance with the applicable regulations and directives.



The connection diagrams and terminal allocation lists for the devices are given in the data sheets.

**Note**

Special instructions for the connection of the external bus system, as for example, recommended bus cables, permissible cable lengths, fieldbus terminators, etc., are given in **Chapter 7 "Integration into the Higher-Level Bus System"**.

## 5 Configuring and Commissioning the RPI System

### 5.1 Offline Commissioning

Offline commissioning enables you to document and largely prepare the RPI system for actual commissioning on your PC during the planning phase.

The RPI system can be configured and the topology can be designed accordingly using the **PACT<sup>ware</sup>** human machine interface. Configuration and parameter assignment can be largely carried out without the RPI system. This kind of commissioning assists you in planning the system and provides support for the documentation.

Having installed the RPI system, it is configured using the push-buttons and the LC-display of the gateway. The project data generated offline is transferred to the gateway in the next step.

These are the steps to be followed during commissioning:

1. The RPI system should be installed according to the planning using the **PACT<sup>ware</sup>** edition 2 human machine interface on the PC. The structure of the RPI system with the gateways, the individual I/O modules and the service interfaces has to be rebuilt accordingly and configured. Parameters for the individual RPI modules are entered in register cards as shown in **Chapter 6 "Parameter Assignment"**.
2. If your RPI system is designed with gateway redundancy, the redundant gateway is inserted in the structure of the RPI system, just below the active gateway. When parameterizing the gateways, please make sure, that the active gateway for the RPI internal bus has address 1 and that the redundant gateway has address 2. Similarly, the gateways receive different addresses for communication on the higher-level fieldbus later on.
3. Installation and connection of the RPI system, as described in **Chapter 4.11 "Installation"**.
4. Switching on the power supply for the RPI system, as described in **Chapter 5.2 "Power Supply"**.
5. The RPI modules are configured via the gateway, see **Chapter 5.4 "Configuration" Parameter Assignment**.
6. For the parameter assignment the PC is connected to the gateway on the service interface RS232 by means of the K-ADP2 adapter or RS485 by means of the K-ADP4 adapter. After that, the project which was generated offline is downloaded to the gateway (see **Chapter 6.4 "Downloading Project Data into the Gateway"**).

When installing a service level with fixed wiring, adapters are not necessary since the networked gateways can be controlled directly from the PC via RS485.

Having transferred the configuration and parameter assignment data, the LEDs and the gateway display indicate possible faults. A verification of the RPI system can be carried out using the diagnostic and simulation functions provided by the **PACT<sup>ware</sup>** man machine interface. The individual fault signals of the RPI modules and the fault signals of the gateway are described in **Chapter 5, Chapter 6** and **Appendix A**.



Note

Commissioning of the gateway on the higher-level fieldbus is described in **Chapter 7**.



Note

During the configuration and parameter assignment of the RPI system, the red LEDs light up to indicate possible faults. While proceeding with commissioning, the LEDs extinguish and at the end of the commissioning procedure the only LED still illuminated is the 'bus external' LED, since an integration into the higher-level bus system has not yet been carried out.

## 5.2 Power Supply

The power feed modules are connected to a 24 V DC power supply. This voltage supply is fed to the Power Rail and hence to all the devices mounted on this rail. Fuses in the power feed modules provide the group fusing.

### 5.2.1 Construction of the Power Feed Module

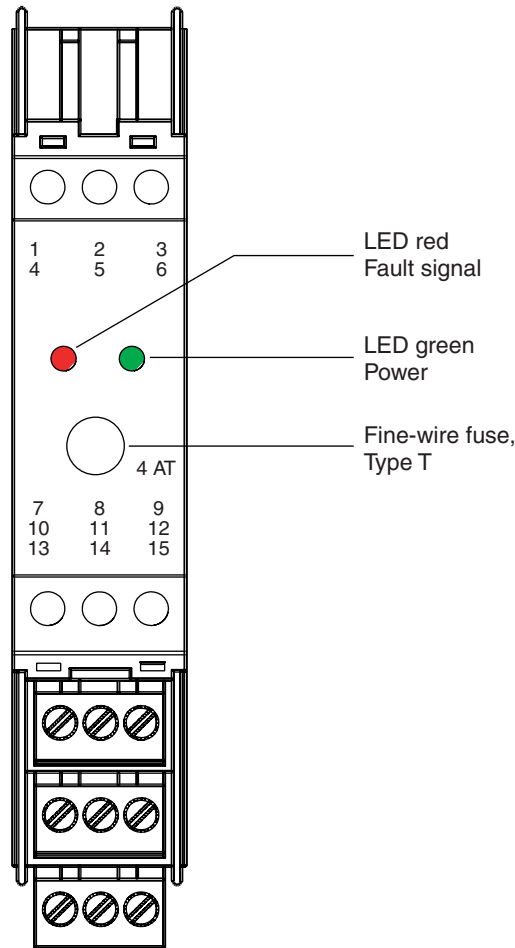

Figure 5.1: Front view of power feed module

The presence of rated operating voltage is indicated by a green 'PWR' LED on the front panel of the device. The status of the fusing is signalled via a red 'fault' LED.

### 5.2.2 Setting the Mode of Operation of the Relay

The response of the fuse is indicated via the energized relay in the setting on delivery. In order to adjust the mode of operation of the relay, first remove the narrow front panel using a suitable screwdriver: Insert the screwdriver into one of the two cutouts and remove the front plate by careful leverage. The cover of the left section can then be gently lifted away from the catches.

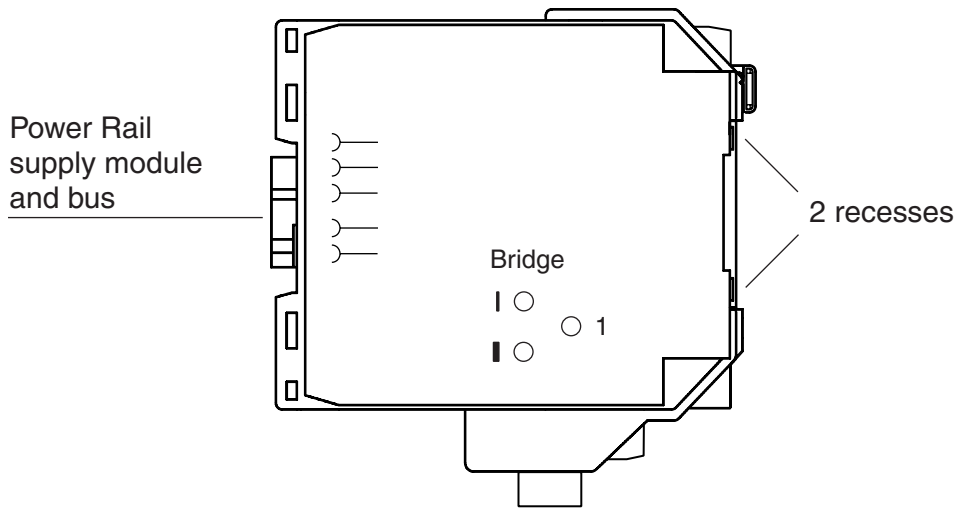

Figure 5.2: Setting the mode of operation of the relay

Jumper between	Mode of operation of the relay
1 and I	Normally open
1 and II	Normally closed

The mode of operation is set to 'normally open' in the setting on delivery.

## 5.3 RPI Devices

### 5.3.1 Construction of the RPI Devices

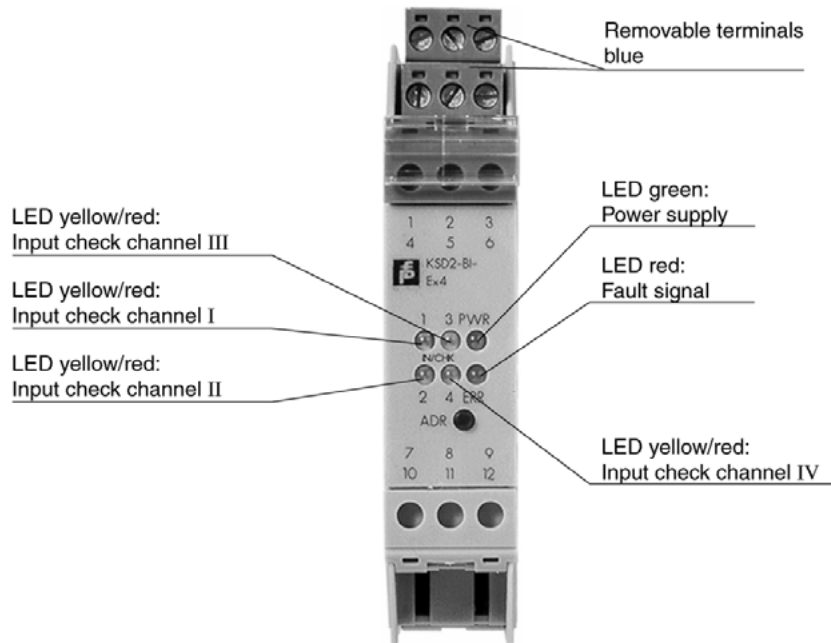

Figure 5.3: Front view of RPI device



The RPI system devices have 1, 2 or 4 input and output channels, depending on the model. The construction, the operation of the devices by means of the ADR button (address), and the LEDs are identical for all models.

An IN/CHK and OUT/CHK LED is available for each individual channel.



The flashing red LED's on the RPI system should not be allowed to cause confusion. They do not extinguish until commissioning is finished.

### 5.3.2 LEDs on the Front Panel of a Device

There are between three and six LEDs on the front panel of a device, which indicate the current status of the device as well as hardware and communication errors.

The following symbols are used in the descriptions below::

	LED off
	Flashing LED
	LED constantly illuminated

## LED PWR (green)

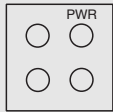

No voltage supply

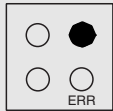

Voltage supply present

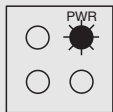

Setting and checking the device address

## LED ERR (red)

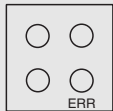

No error

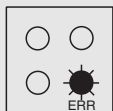

Bus error

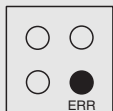

Hardware error (specification via LED IN/CHK or OUT/CHK)

## LED (s) IN/CHK or OUT/CHK (1 ... 4)

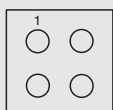

Input/Output channel 1 not active

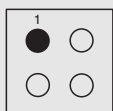

Yellow LED: Input/Output channel 1 active

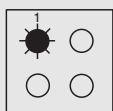

Red LED: Lead breakage or short circuit in the field circuit, channel 1

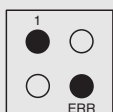

Red LED 1 and ERR-LED: EEPROM error

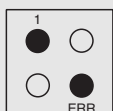

Yellow LED 1 and ERR-LED: Communication error

## 5.4 Configuration

In Chapter 4 "Planning of the RPI System" of this handbook the layout of the RPI system was planned. The RPI devices and gateways, the voltage supply as well as the addresses for the individual devices were determined.

The basic configuration of the system is described in this chapter. The following table provides an overview of the configuration steps and the respective menu items for configuration directly on the gateway.

Configuration step	Menu item for gateways KSD2-GW-...	Menu item for gateways SD2-GW2-...
Addressing the gateway on the internal bus (address 1 = prior, 2 = redundant)	b	RedMode
Set RPI internal address for the devices (addresses 3...127)	b	AdrAssign
Addressing the gateway on the external bus	d	
Addressing the service interface	E	ParAdr
Setting the baud rate for the service interface	G	ParBaud
Only MODBUS: Setting the baud rate for the external bus	H	n.a.
Only MODBUS: Setting the parameter values for the external bus	I	n.a.
Optional: Uploading the current RPI device configuration to the gateway (*)	A, then press 'Mode' button > 3 sec.	Teach-In
Note: Normal operation mode of the gateway	A	Run

Tabelle 5.4: Configuration procedure

### (\*) Teach-in of an existing configuration

If the RPI devices already have addresses on the internal bus, the structure can be uploaded to the gateway by means of the 'Teach-in' function. Existing parameters are likewise uploaded from the RPI devices. This function helps you to commission RPI quickly or to teach-in hardware changes. However, you must ascertain, that you keep track of these changes in your software human machine interface!

Alternatively, the values for the configuration of the RPI system can be set by means of a software human machine interface or via PROFIBUS DP.

A detailed description of the configuration via the gateway can be obtained from

**Chapter 5.4.2 "Operating the Gateways Type KSD2-GW-..."**

or

**Chapter 5.4.3 "Operating the Gateways of Type KSD2-GW2-..."**

## 5.4.1 Construction of the Gateways and LEDs on the Front Panel

The four LEDs on the front panel indicate the current status of the device as well as hardware and communication errors. The four LEDs are identical for the gateways KSD2-GW-... and KSD2-GW2-... .

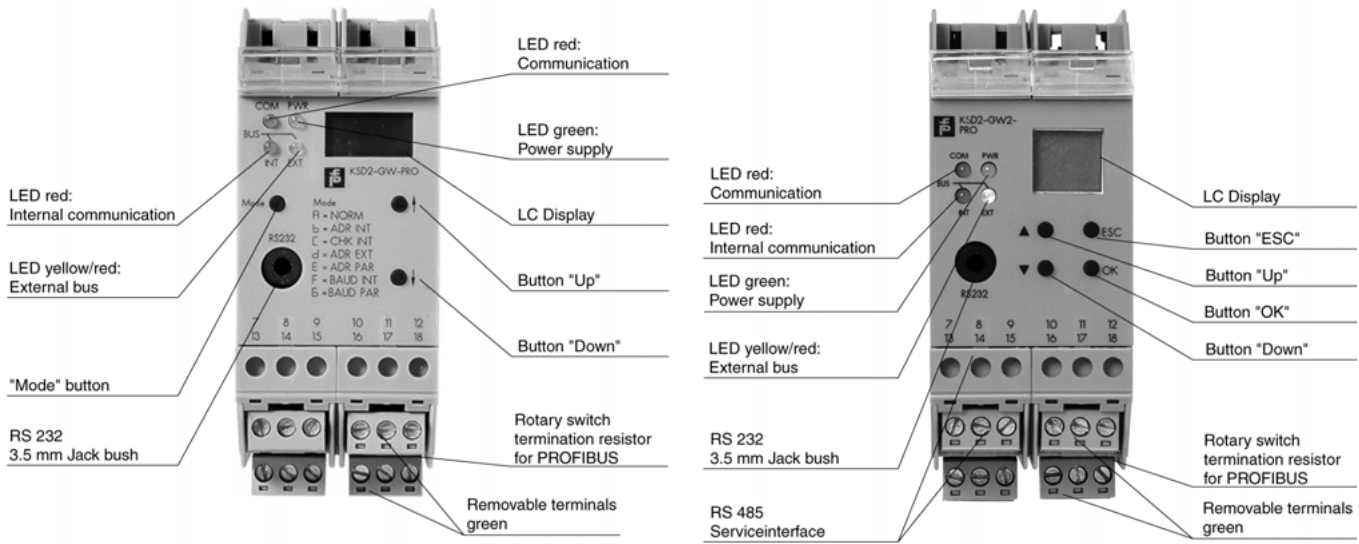
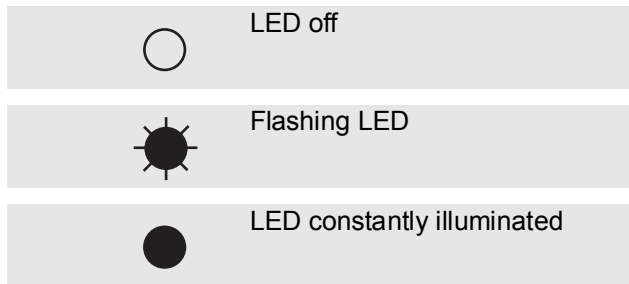
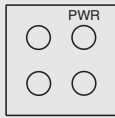

Figure 5.5: Front view of KSD2-GW-... and KSD2-GW2-... gateway

The following symbols are used in the descriptions below:



## LED PWR (green)



No voltage supply

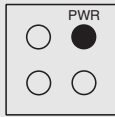

Voltage supply present

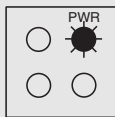

Display of the gateway address for the RPI internal bus

## LED INT (red)

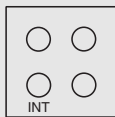

Internal bus in normal operation

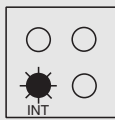

Internal bus or device error

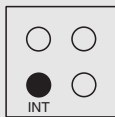

Internal interface error

## LED EXT (yellow / red)

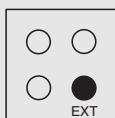

Yellow LED: External bus in normal operation

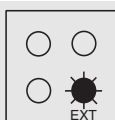

Red LED : No communication on external bus

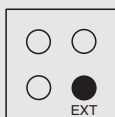

Red LED : Internal interface error

## LED COM (red)

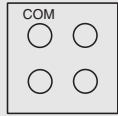

Normal condition: Internal CAN bus in differential mode

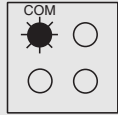

Internal CAN bus in common mode, redundancy failure

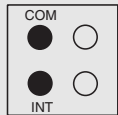

RAM/ROM/EEPROM error, or other internal error

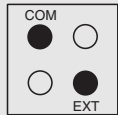

RAM/ROM error, or other error (red EXT LED lights)

**5.4.2 Operating the Gateways Type KSD2-GW-...**

The operating modes and parameters can be set by means of the three pushbutton switches “Mode”, “Up Ñ” and “Down Ò” and the 3 1/2 digit LC display. The last position on the display is a letter, that indicates the current operating mode. The operating modes can be identified from the table provided on the front panel.

<b>A = NORM</b>	Normal operation
<b>b = ADR INT</b>	Assignment of device addresses, internal bus
<b>C = CHK INT</b>	Checking device addresses, internal bus
<b>d = ADR EXT</b>	Setting the gateway address, external bus
<b>E = ADR PAR</b>	Set the gateway address, service interface
<b>F = BAUD INT</b>	Set baud rate, internal bus
<b>G = BAUD PAR</b>	Set baud rate, service interface
<b>H = BAUD EXT</b>	Set baud rate, external bus (only MODBUS gateway)
<b>I = PARAM EXT</b>	Set parameter values, external bus (only MODBUS gateway)

The first three digits displayed show the status, addresses or parameters, depending on the set operating mode.

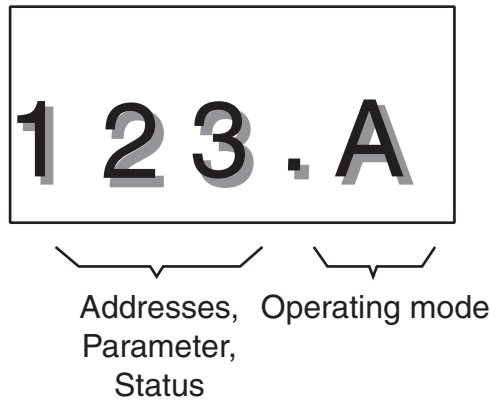

**Normal operation**

During normal operation the menu identifier “A” appears in the gateway LC display:



If a device error message is communicated via the internal bus, the display shows the address of the faulty device and the error code, alternately: The table of error codes is given in Chapter 5.4.2.10 :



## 5.4.2.1 Allocation of the Device Addresses on the Internal Bus

In Section 4, addresses were allocated to the RPI devices while planning the system. (see **Chapter 4.1.8 "Layout and Addressing of the RPI Devices"**). Now these addresses must be set in the RPI devices.

The device addresses are organised as follows:

Address	Device
0	Neutral address of an RPI device (the setting on delivery)
1	Active RPI gateway
2	Redundant RPI gateway
3 ... 127	RPI device

- On selecting the operating mode b = ADR INT (set internal address) using the "Mode" button on the gateway, the lowest possible free device address is shown on the display.
- Select the desired device address using the "Up" and "Down" buttons. Occupied and prohibited addresses are not displayed.
- If the ADR pushbutton on the front panel of the device that is to be addressed is depressed for longer than 3 s,
- the displayed address is allocated to this device. This is indicated by the green LED PWR on the device and the gateway flashing for a brief period.

## 5.4.2.2 Checking the Device Addresses on the Internal Bus

On selecting the operating mode C = CHK INT there are two principal ways of checking the address of a device:

1. By ascertaining the device that has the address that is indicated on the gateway display.  
The address on the gateway display can be set using the ↓ and ↑ buttons. Only addresses which are actually available on the internal bus are displayed.  
The green PWR LED flashes on the device whose address is shown on the gateway display.
2. By determining and displaying the address which is held by a particular device.  
Briefly depress the ADR button (less than 3 s) on the device that is to be identified.  
The gateway display shows the address of the device. On the device itself, the green PWR LED flashes.

## 5.4.2.3 Setting the Gateway Address on the External Bus

On selecting operating mode d = ADR EXT, the currently set address appears in the display. The address can be reset by means of the ↓ and ↑ pushbuttons. The set address is accepted on depressing the mode button for longer than 3 s.

## 5.4.2.4 Setting the Address of the RS 232/RS 485 Service Interface

The RPI human machine interface supports the simultaneous connection of a PC to a number of gateways as a subordinate service level. Up to 31 gateways can be managed and parameterised if the installed PC and the gateways operate via RS 485 interfaces.

On selecting the operating mode E = ADR PAR, the currently set address is shown in the display (default: 0). The address (address range 0 ... 31) can be reset using the ↓ and ↑ buttons. The address is accepted by depressing the mode button for longer than 3 s.

## 5.4.2.5 Transfer Rate of the Internal Bus

The operating mode F = BAUD INT shows the set baud rate of 250 kbit/s of the internal bus.

**5.4.2.6 Setting the Transfer Rate of the RS232/RS 485 Service Interface**

On selecting the operating mode G = BAUD PAR, the currently set transfer rate is shown in the display. The transfer rate for the RS 232 / RS 485 service interface can be set by means of the ↓ and ↑ pushbuttons. The set transfer rate is accepted by depressing the mode button for longer than 3 s.

The following transfer rates can be set:

Transfer rate	Display indication
1.2 kbit/s	1
2.4 kbit/s	2
4.8 kbit/s	4
9.6 kbit/s	9
19.2 kbit/s	19
28.8 kbit/s	28
33.6 kbit/s	33
38.4 kbit/s	38
57.6 kbit/s	57

The transfer parameters for the RS 232/RS 485 service interface are fixed and cannot be changed:

- 1 Start bit
- 8 Data bits
- 1 Stop bit
- Even parity



Note

Compare the transfer parameters with the values of your PC, indicated in the menu item "system control".

**5.4.2.7 Setting the Transfer Rate of the External MODBUS**

On selecting the operating mode H = BAUD EXT (only available on MODBUS gateway) the currently set transfer rate is shown in the display. The MODBUS transfer rate can be set by means of the ↑ and ↓ buttons. The set transfer rate is accepted by depressing the mode button for longer than 3 s.

The following transfer rates can be set:

Transfer rate	Display indication
1.2 kbit/s	01
2.4 kbit/s	02
4.8 kbit/s	04
9.6 kbit/s	09
19.2 kbit/s	19
28.8 kbit/s	28
38.4 kbit/s	38
57.6 kbit/s	57

## 5.4.2.8 Setting the MODBUS Parameters

On selecting the operating mode I = PARAM EXT (only available on MODBUS gateway) the current setting is shown in the display. A different setting can be selected using the  $\uparrow$  and  $\downarrow$  pushbuttons and accepted by depressing the mode pushbutton for longer than 3 s. The following settings are available:

Setting	Display indication
No parity bit, 1 stop bit	00
Odd parity, 1 stop bit	01
Even parity, 1 stop bit	02
No parity bit, 2 stop bits	03

## 5.4.2.9 Teaching-in Existing Configurations of the RPI Devices

The current configuration of all connected RPI devices is uploaded to the gateway using the 'Teach-in' function. Likewise, existing parameter data of the devices is uploaded to the gateway.

This function is helpful in starting-up the RPI rapidly, or in teaching-in hardware changes rapidly. However, you must ascertain that you keep track of these changes in your software human machine interface.

Depress the "mode" button for longer than 3 seconds. All new settings of the RPI devices are now stored in the gateway.



Note

Bear in mind, that you can use the human machine interface to keep track of the set-up of your project.

This can be accomplished by means of the 'Project upload' function of the **PACT<sub>ware</sub>**<sup>TM</sup> human machine interface.

**5.4.2.10 Error Messages in the LC-Displays of the Gateways**

If a device error message is communicated via the internal bus, the LC-display shows the address of the faulty device and the error code, alternately.

The addresses and error codes of other faulty devices can be shown in the display by means of the ↓ and ↑ pushbuttons:

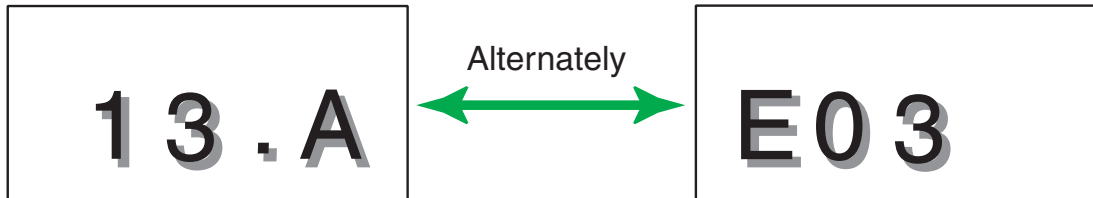

The error codes have the following meanings:

<b>Error code</b>	<b>Significance</b>
01	A device included in the gateway configuration does not exist as a station on the internal bus
02	Device address indicates it is not included in the gateway configuration
03	Incorrect device type
04	Device error
05	Channel error, e.g. lead breakage or short circuit of the signal circuit of the faulty device (for channel No. see device LED)
06	Device in initialisation phase
07	Addressing conflict
08	Device is being simulated
81	Redundant communication failure - internal communication
82	Redundant communication failure - external communication
83	Loss of redundancy - user initiated
84	Check sums of the parameter sets in the active and passive gateway are not the same

Tabelle 5.6: Error codes



Note

It is recommended, that on the occurrence of an error message, the “Up” and “Down” buttons are always pressed in order to be able to detect errors in other devices. The RPI system can also be operated without an external bus connected. In this case the “EXT” LED flashes.

It is possible to simulate individual RPI modules during normal operation. Bear in mind, that simulated signals could interact with your process.

Further information on maintenance and diagnosis can be found in **Chapter 8 "RPI in Operation"**

### 5.4.3 Operating the Gateways of Type KSD2-GW2-...

The gateways of type KSD2-GW2-... have four buttons "OK", "Esc", "Up" and "Down", four LEDs and an LC-display. The function of the LED corresponds to the description in Chapter 5.3.2 on Page 69.

The LC-display shows the following information:

- Operating data of an RPI device as well as of the individual channels
- Error messages of the RPI devices
- Operating modes and parameters during the configuration of the RPI system

In normal operation "run" appears in the display.

On depressing the "OK" button, the data menu which displays the operating data appears.

Using the key combination "Esc" + "OK", the service menu appears. It enables you to carry out the settings for the configuration data.

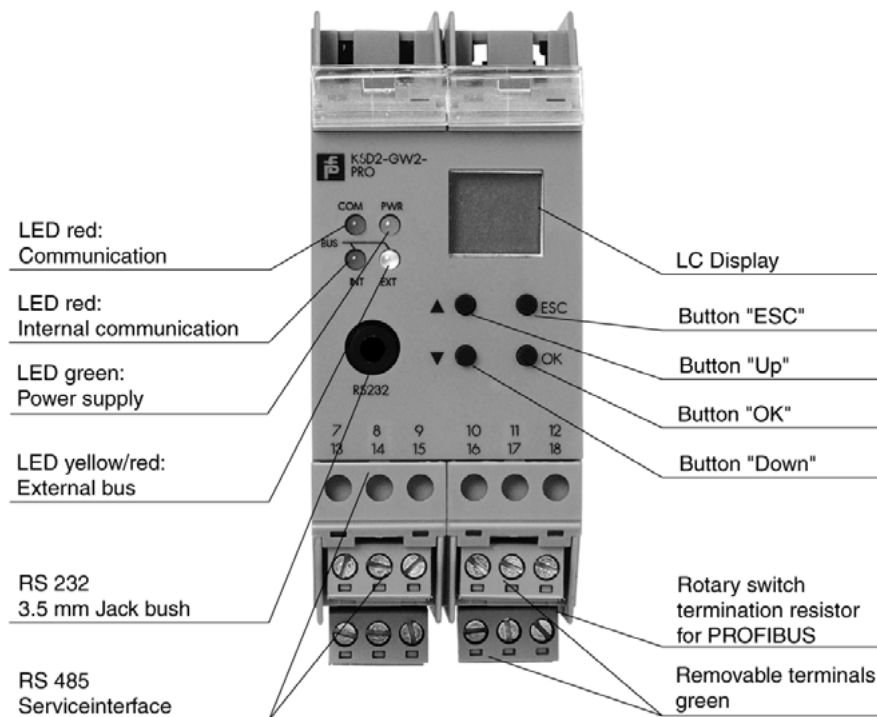

Figure 5.7: Front view of KSD2-GW2-PRO Gateway

#### 5.4.3.1 Normal Operation: 'Run' Menu

During normal operation the information "run" appears in the gateway LC display.

The following diagram shows the menu logic of the gateway. The commands in the middle of the arrows represent strokes on the corresponding keys of the gateway. In general, the following applies to the commands:

- "OK" guides the user to the next operator level or confirms an input
- "Esc" guides the user back to the preceding operator level or aborts an input
- "Up" and "Down" pages the display elements or input values within each operator level
- "Esc" and "OK" depressed simultaneously guides the user from the normal mode to the service mode, where inputs can be made.

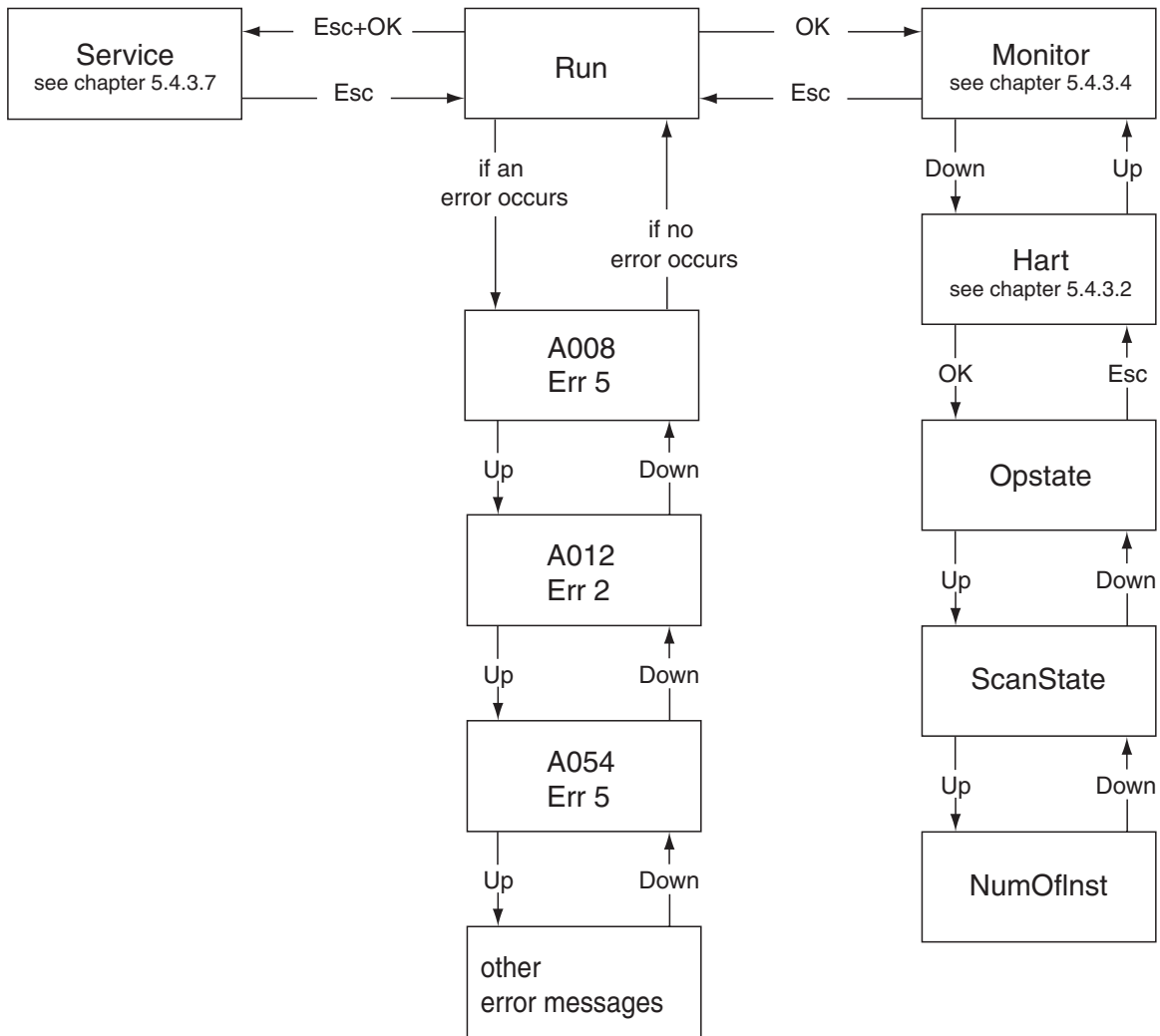

Figure 5.8: 'Standard' menu

### 5.4.3.2 HART Communication: 'HART' Menu

Depressing "OK" guides the user from the 'Run' normal mode to the display mode. Here the user can toggle between the display of the process data and the display of the HART communication status.

HART communication status:

- OpState                    HART communication active
- ScanState                HART communication in scan mode
- NumOfInst                Number of installed HART loops



In order to carry out HART communication, the HART support of the gateway must be activated. See **Chapter 5.4.3.7 "Input of Configuration Data: 'Service' Menu"**.

### 5.4.3.3 Fault

If device error messages are communicated via the internal bus, the display shows the device with the lowest address and its error code. The addresses and error codes of other faulty devices can be shown in the display using the "Up" and "Down" buttons.

The error codes have the following meanings:

Error code	Significance
01	A device included in the gateway configuration does not exist as a station on the internal bus
02	Device address indicates it is not included in the gateway configuration.
03	Incorrect device type
04	Device error
05	Channel error, e.g. lead breakage or short circuit of the signal circuit of the faulty device. for channel No. see device LED.
06	Device in initialisation phase
07	Addressing conflict
08	Device is being simulated
81	Redundant communication failure - internal communication
82	Redundant communication failure - external communication
83	Loss of redundancy - user initiated
84	Check sums of the parameter sets in the active and passive gateway are not the same



It is recommended, that on the occurrence of an error message, the "Up" and "Down" buttons are always pressed in order to be able to detect errors in other devices. The RPI system can also be operated without an external bus connected. In this case the "EXT" LED flashes.

It is possible to simulate individual RPI modules during normal operation. Bear in mind, that simulated signals could interact with your process.

Further information on maintenance and diagnosis can be found in **Chapter 8 "RPI in Operation"**

### 5.4.3.4 Indication of Measured Values: 'Monitor' Menu

Device and channel-specific information can be retrieved from the 'Monitor' menu. The current address of the device, the device type (BI, BO, AI, AO, ...), and the channel number is shown in the LC-display. If an error is communicated for this address, the error instead of the device type is indicated.

- Button "Up" or "Down": next device
- Button "OK": measured values of the set device; in the case of multi-channel devices, the "Up"/"Down" buttons can be used to toggle between the channels.

The current measured value together with the channel number appears in the display as channel-related information. Channel-specific errors are abbreviated and added to the channel number.

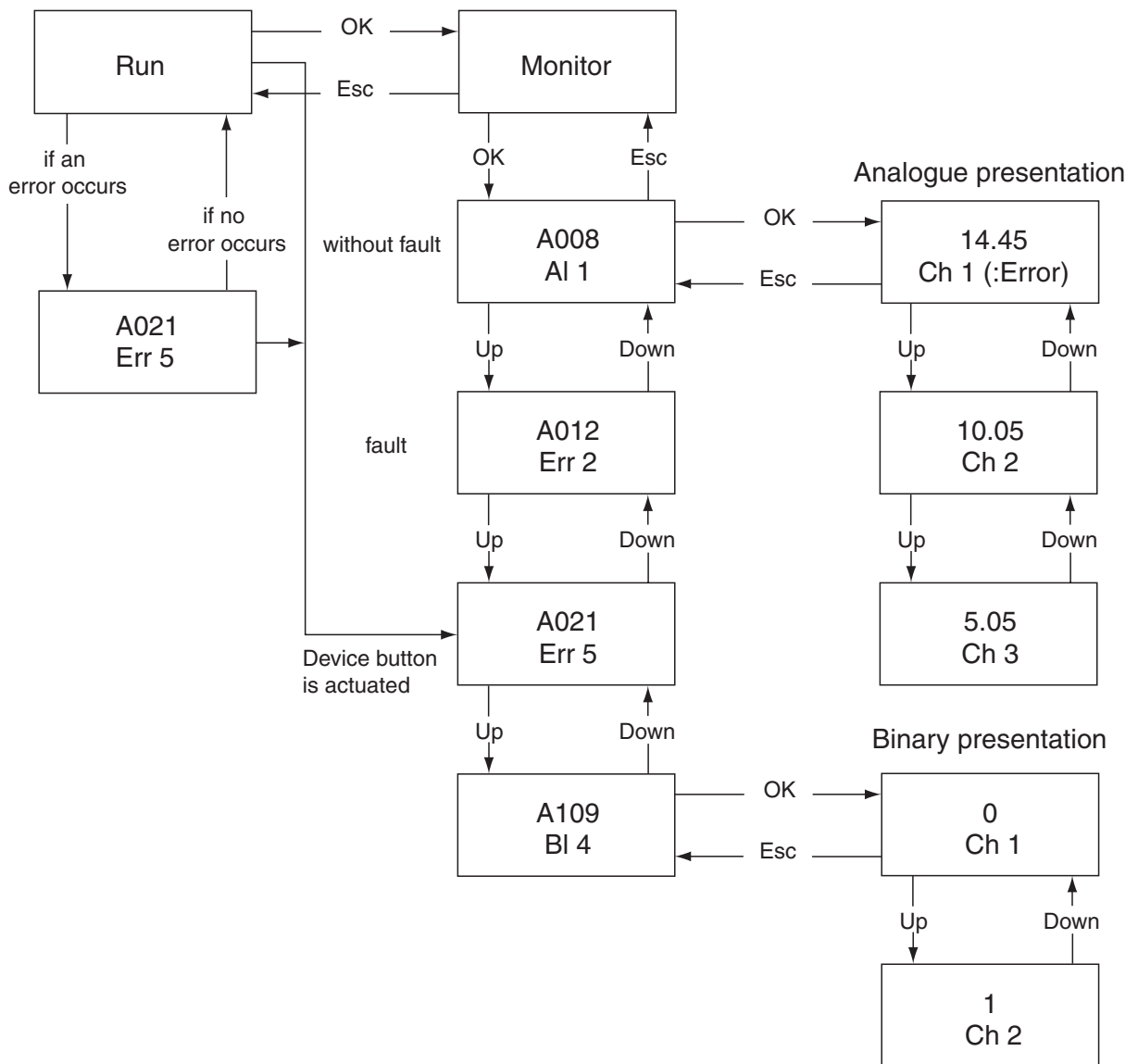

Figure 5.9: 'Monitor' menu

For binary channels the states appear as 0 or 1 in the display.

If the transferred measured value of analogue channels is outside the number range of -999 to 9999, "OFL" is indicated.

The PWR LED flashes on the RPI device, whose measured value is shown on the display.

#### 5.4.3.5 Checking the Device Addresses on the Internal Bus

There are two principal ways of determining the address which is held by a particular RPI device:

1. By selecting the device in the 'Monitor' menu of the gateway. On the RPI-device itself, the green PWR LED flashes.
2. By briefly (less than 3 s) depressing the ADR button of the device. The gateway should be in the 'Run' or in the 'Monitor' menu. The gateway display shows the address of the device and the device type. Now, the gateway is in the 'Monitor' menu and should be reset to normal mode 'Run' by means of the "Esc" button. The green PWR LED flashes on the device.

### 5.4.3.6 Error Messages

The following error messages are indicated and abbreviated.

Data structure	Error	Display	Comment
-	Err 01	Dev miss	Device not available
-	Err 02	Dev not conf	Device not configured
-	Err 03	Wrg Dev	Wrong device
-	Err 04	Dev Err	Device causes error
-	Err 05	Chn Err	Channel causes error
-	Err 06	Lin Err	Error in linearization table
-	Err 07	Addr Confl	Two devices with same address
-	Err 08	Sim	Device in simulation mode
Divice Diag.	E2PR_ERR	MEM	Memory error
	APPL_ERR	INT	Internal interface
	CAN_H_FAULT	CAN_H	CAN Bus connection: short-circuit
	CAN_L_FAULT	CAN_L	CAN Bus connection: lead breakage
	All other	NOT DEF	Not defined or supported
Func Diag.	SHORT_CIRC	SC	-
	LEAD-BREAK	LB	-
	LO-ALM	LO_WRN	Low signal: warning
	HI_ALM	HI_WRN	High signal: warning
	LO_LO_ALM	LO_ALM	Low signal: alarm
	HI_HI_ALM	HI_ALM	High signal: alarm
	UNDER_RANGE	UR	-
	OVER_RANGE	OR	-
	All other	NOT_DEF	Not defined or supported

### 5.4.3.7 Input of Configuration Data: 'Service' Menu

The data for the configuration of the gateway, HART transmission and the address allocation to the RPI devices can be entered in the 'Service' menu. User prompting via LC-display is shown in the diagram below.

The service menu is entered by simultaneously depressing the "Esc" and "OK" buttons and reconfirming with "OK".

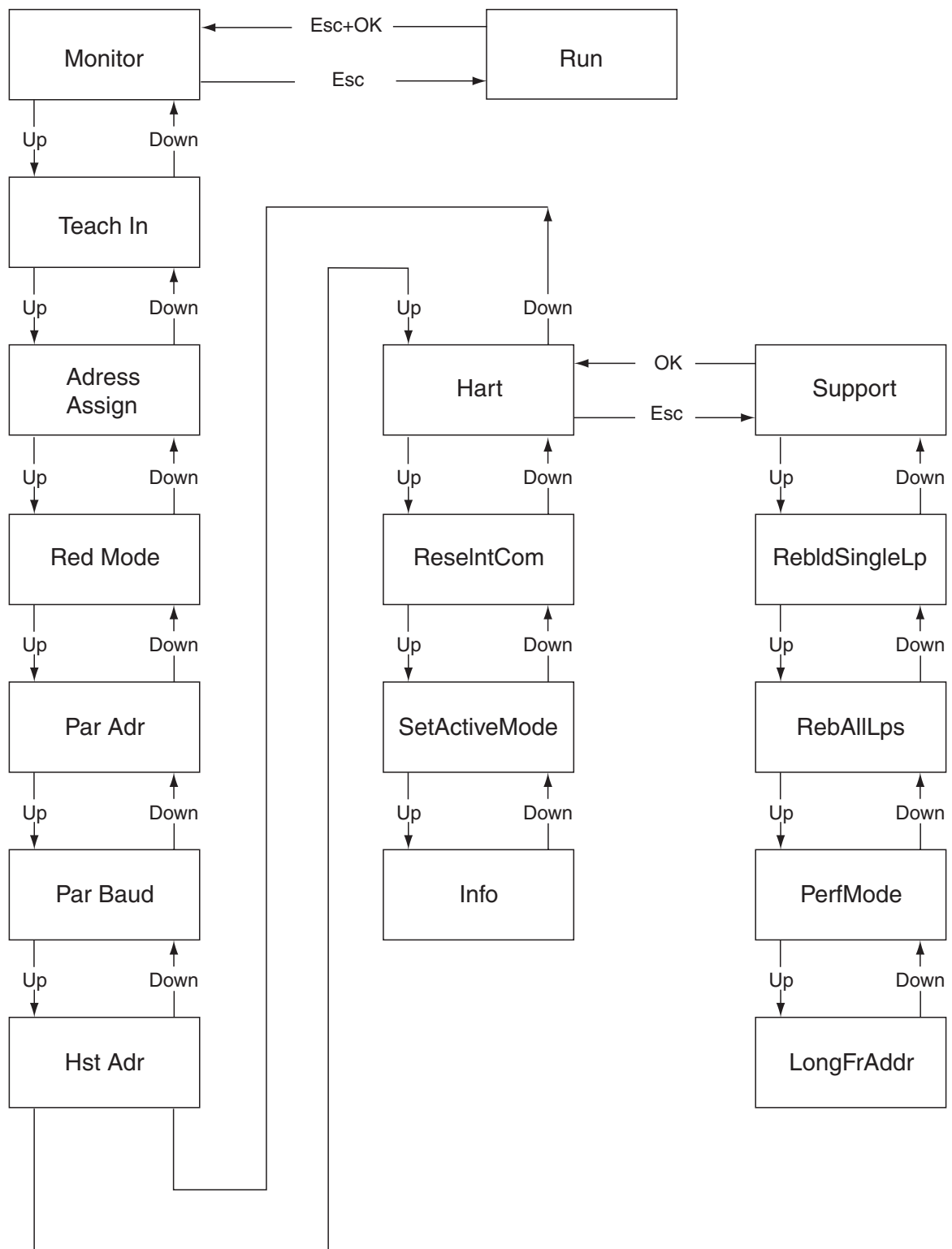

Figure 5.10: 'Service' menu

### 5.4.3.8 General Information on Input of Parameters and Values

The input mode is selected by depressing the "OK" button for every menu item of the "Service" menu. The display flashes and can be changed using the "Up" and "Down" buttons within the predefined range of values. "Esc" guides the user back to the source value; "OK" confirms the indicated value which stops flashing. "Esc" guides the user back to the service menu.

Date of issue 05/27/03

The following diagram shows the input of parameters and values. This procedure applies to all variable parameters and values.

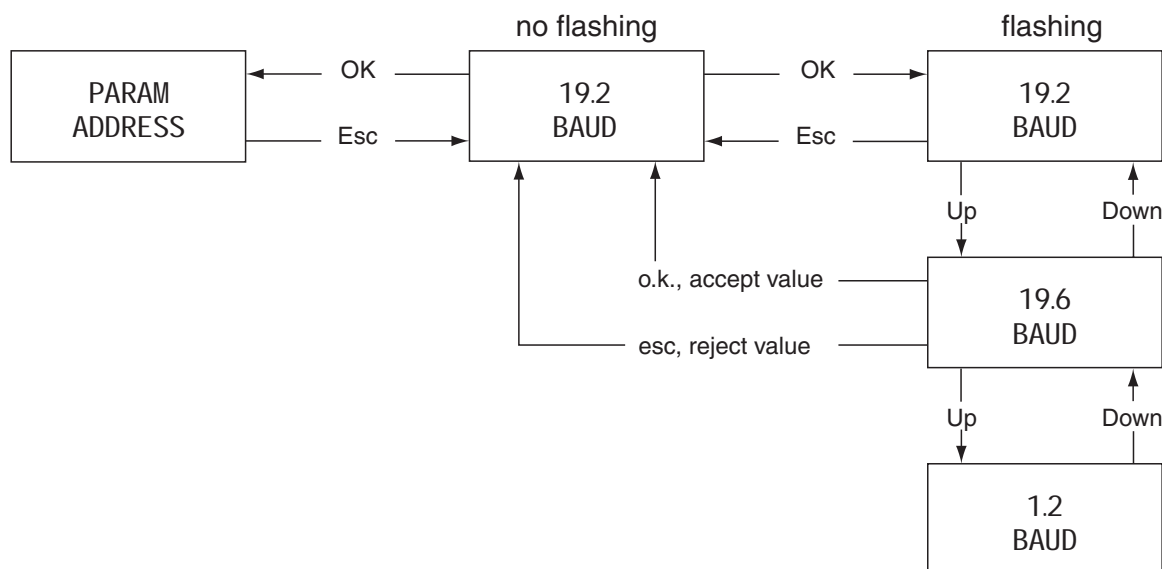

Figure 5.11: Changing parameters and values

#### 5.4.3.9 Teaching-In the RPI Configuration: 'Teach-In' Service Menu

The current configurations of all connected RPI devices are uploaded to the gateway by means of 'Teach-In'. Existing parameter data of the devices is likewise uploaded.

This function helps you to start-up the RPI rapidly, or to teach-in hardware changes. However, you have to ascertain that you keep track of these changes in your software human machine interface!



Note

Bear in mind, that you can use the human machine interface to keep track of the set-up of your project.  
In **PACT<sup>ware</sup>** this is accomplished using the 'Project upload' function.

#### 5.4.3.10 Assignment of Device Addresses: 'AdrAssign' Service Menu

The 'Address Assign' menu is used to transfer the desired address for an RPI device on the gateway:

- Set the desired address using the "Up" and "Down" buttons. Only free addresses are indicated.
- The address is transferred to the RPI device by depressing the ADR pushbutton on the front panel of the device that is to be addressed for longer than 3 s.
- The green LED on the gateway flashes for a brief period; the display of the gateway shows the next free address.

The device addresses are organised as follows::

Address	Device
0	Neutral address of an RPI device, (the setting on delivery)
1	Active RPI gateway - see Set Gateway Mode
2	Redundant RPI gateway - see Set Gateway Mode
3 ... 127	RPI device

#### 5.4.3.11 Activation of the Redundancy: 'RedMode' Service Menu

The redundancy function of the gateway is determined in this menu. The priority gateway obtains the setting master "Mst." and hence also the internal address 1; the redundant gateway is set to "Red." and thus obtains the internal address 2.

#### 5.4.3.12 Setting the Address of the RS 232/RS 485 Service Interface: 'ParAdr' Service Menu

**PACT<sup>ware</sup>**® human machine interface supports the simultaneous connection of a PC to a number of gateways as a subordinate service level. Up to 31 gateways can be managed and wired with the RS 485 interface of a PC.

Each individual gateway can be connected to a PC by means of an adapter cable via the RS232 interface in the gateway. Parallel operation of the two interfaces is possible.

Establishing an address from 0 to 255 for the parameterization interface is possible by means of the 'Parm Address' menu.

#### 5.4.3.13 Setting the Transfer Rate for the RS 232/RS 485 Service Interface: 'ParBaud' Service Menu

On selecting the 'ParBaud' menu, the currently set transfer rate is shown in the display. The following transfer rates can be set:

Transfer rate	Display indication
1.2 kbit/s	1200 Baud
2.4 kbit/s	2400 Baud
4.8 kbit/s	4800 Baud
9.6 kbit/s	9600 Baud
19.2 kbit/s	19.2 kBaud
28.8 kbit/s	28.8 kBaud
33.6 kbit/s	33.6 kBaud
38.4 kbit/s	38.4 kBaud
57.6 kbit/s	57.6 kBaud

The transfer parameters for the RS232/RS485 service interface are fixed and cannot be changed:

- 1 Start bit
- 8 Data bits
- 1 Stop bit
- Even parity



Note

Compare the transfer parameters with the values of your PC listed in the menu item "System Control".

### 5.4.3.14 Setting the Gateway Address on the External Bus: 'HstAdr' Service Menu

On selecting the 'Host Address' menu, the currently set gateway address on the higher-level fieldbus is shown in the display. It can be changed in a range of 0 ... 126.

### 5.4.3.15 Setting the HART Transmission: 'HART' Service Menu

In this menu the parameters for the HART protocol transmission are set by means of the HART Multiplexer which is integrated in the gateway.

The following submenus can be selected using the "Up" and "Down" buttons:

- Support: Activates the HART support. Settings: On / Off
- ReblSingleLp: Individual HART loops can be built up. Settings: 0 to 255
- RebAllLps: All connected HART loops are rebuilt. This process can be extremely time-consuming, depending on the application!
- PerfMode: This is where the operating mode for the HART support can be determined with regard to the details of the HART standard:
  - nor: Normal mode, secondary master and Burst mode are permitted
  - FAST: Only Burst mode permitted
  - HI: Neither Burst mode nor secondary master are permitted
- LongFrAddr: The Long Frame Address can be uploaded here. Display: Byte 1.... byte 5

### 5.4.3.16 Resetting Internal Communication, 'ResIntCom' Service Menu

This menu enables a synchronization procedure to be initiated on the internal bus, in order to allow the system to change from redundant operation to normal operation. The procedure is initiated using the key combination which is also used to save parameters.

### 5.4.3.17 Switching Back from Redundant Operation: 'SetActiveMode' Service Menu

This command relates to the external gateway-redundancy. If the system is in redundant operation, and if the priority gateway is available again, the latter is reactivated by means of this function. In this case, the same functions as in the 'ResIntCom' and 'TeachIn' menus are performed.

### 5.4.3.18 Information on Hardware and Software Versions: 'Info' Service Menu

The version of the gateway is indicated in this menu:

1. SWRem: Software version internal bus
2. SWHst: Software version PROFIBUS
3. HWVer: Gateway hardware version

**5.5 Verification of Device Addresses**

**5.5.1 Checking the Device Address on the RPI Internal Bus**

**5.5.1.1 Checking by Means of KSD2-GW-... Gateway**

On selecting the operating mode C = CHK INT, there are two principal ways of checking the address of a device:

1. By ascertaining the device that has the address that is indicated on the gateway display:  
Cycle through the addresses on the gateway display, using the ↓ and ↑ buttons. Only those addresses are displayed which are actually present on the internal bus.  
The green PWR LED flashes on the device whose address is shown on the gateway display.
2. By determining and displaying the address which is held by a particular device:  
Briefly depress the ADR button (less than 3 s) on the device that is to be identified.  
The gateway display shows the address of the device. On the device itself, the green PWR LED flashes.

**5.5.1.2 Checking by Means of KSD2-GW2-... Gateway**

There are two principal ways of checking the address which is held by a particular RPI device:

1. By selecting the device in the 'Monitor' menu of the gateway. On the RPI-device itself, the green PWR LED flashes.
2. By briefly depressing the ADR button (less than 3 s) on the device. The gateway should be in the 'Run' or in the 'Monitor' menu. The gateway display shows the address of the device and the device type. Now the gateway is in the 'Monitor' menu and should be reset to the normal mode 'Run' by means of the "Esc" button. On the device itself, the green PWR LED flashes.

**5.5.2 Assignment of the Device Address for the Internal Bus**

The device addresses of the RPI internal bus are organised as follows::

Address	Device
0	Neutral address of an RPI device, (the setting on delivery)
1	Active RPI gateway
2	Redundant RPI gateway
3 ... 127	RPI device

**5.5.2.1 Address Assignment by Means of KSD2-GW-... Gateway**

- Select the operating mode b = ADR INT (set internal address) with the "Mode" button on the gateway. The lowest possible free device address is shown on the display.
- The device address can be changed using the "Up" and "Down" buttons. Occupied and prohibited addresses are not displayed.
- After that, depress the ADR pushbutton on the front panel of the device that is to be addressed for longer than 3 s.
- The displayed address is allocated to the device. This is indicated by the green LED PWR flashing briefly on the device and on the gateway.

**5.5.2.2 Address Assignment by Means of KSD2-GW2-... Gateway**

- Use the buttons of the gateway to select the 'Service' menu, as described in Chapter 5.4.3 on Page 80 .
- Select the service menu 'Address Assign'
- The address can be changed using the "Up" and "Down" buttons. Only free addresses are displayed.
- The address is transferred to the RPI device by depressing the ADR pushbutton on the front panel of the device that is to be addressed for longer than 3 s.
- The green LED on the gateway flashes for a brief period and the gateway display shows the next free address.

Date of issue 05/27/03

### 5.5.3 Assignment of the Neutral Device Address 0 for the Internal Bus

The address of an operational device can be reset to the neutral address 0 (the setting on delivery), by snapping the device without a gateway on to a Power Rail with power supply, and then depressing the "ADR" button of the device for longer than 3 s.



Note

The parameters of the device do not need to be deleted, since they are automatically overwritten by the gateway when the device is used as replacement device.

## 5.6 Configuration of RPI Devices with Automatic Address Assignment Using PACT<sup>ware</sup><sup>TM</sup>

The parameter assignment of the RPI devices can be prepared offline during the planning phase of the RPI system; see **Chapter 6**.



A detailed description of the software human machine interface **PACT<sup>ware</sup><sup>TM</sup>** edition 2 can be obtained from the **PACT<sup>ware</sup><sup>TM</sup>** edition 2', handbook . The handbook is available for download on: <http://www.pepperl-fuchs.com/pa/accessories/pactware/main.html>

The RPI devices can be allocated to both the planned parameters and the RPI internal addresses during the mechanical layout of the system.

### 5.6.1 Configuration via the Service Interface

1. Project the RPI system using the human machine interface **PACT<sup>ware</sup><sup>TM</sup>** edition 2 on the PC, as described in **Chapter 4 "Planning of the RPI System"**.
2. Prepare the installation of the RPI system following the details given in **Chapter 4 "Planning of the RPI System"**. Mount the power feed modules and gateways at the appropriate positions on the Power Rails. Keep the RPI devices ready, but do not yet mount them on the Power Rail.
3. Switch on the power supply for the RPI system, see **Chapter 5.2 "Power Supply"**
4. Configure the gateways as described in Chapter 5.4.2 for the KSD2-GW-... type and in Chapter 5.4.3 for the KSD2-GW2-... type.
5. Connect your PC, with **PACT<sup>ware</sup><sup>TM</sup>** edition 2, and your configured RPI system on it, to the gateway. Please use adapter K-ADP2 for RS232 or K-ADP4 for RS485, depending on the service interface. After that, you should download the offline generated project to the gateway.
6. Snap the individual RPI devices onto the Power Rail one after the other, in ascending order of address according to your project. In so doing, the device is allocated an RPI internal address and the related parameter data is downloaded to the device.  
Make sure:
  - that you commence with the RPI device with the lowest RPI address.
  - that the devices have RPI address 0 prior to commissioning.

### 5.6.2 Acceptance of the Configuration and Parameter Assignment of an Existing RPI System

In case your RPI system is already configured or in operation, the parameter data of the RPI devices can be transferred to the gateway and further on to the **PACT<sup>ware</sup><sup>TM</sup>** human machine interface.

This is helpful for changing RPI devices, replacing a gateway or documenting the system using the **PACT<sup>ware</sup><sup>TM</sup>** human machine interface.



Be sure to keep track of the documentation of your project on the human machine interface. This can be done by using the 'Project upload' function of the **PACT<sup>ware</sup><sup>TM</sup>** human machine interface.

#### 5.6.2.1 Gateway Type KSD2-GW-...

Set operating mode 'A' on the gateway and depress the "mode" button for longer than 3 seconds. All new settings of the RPI devices are now stored in the gateway.

#### 5.6.2.2 Gateway Type KSD2-GW2-...

Select the 'Service' menu by simultaneously depressing the 'Esc' and 'OK' button on the gateway. The data from the RPI devices are transferred to the gateway using the 'Teach-in' service menu.

### 5.6.3 Checking the Configuration and Parameter Assignment

After the configuration and parameterization data has been transmitted, possible errors are indicated on the LEDs and on the display of the gateway. A verification of the RPI system can be carried out by means of the diagnostic and simulation functions provided by **PACT<sub>ware</sub><sup>TM</sup>**. The individual error messages of the RPI modules are described in **Chapter "Monitoring, Simulating Measured Values and Error Handling"** and the error messages are described in **Chapter 11 "RPI System Error Messages"**.

### 5.7 Online Commissioning

Online commissioning implies that the PC with the human machine interface **PACT<sub>ware</sub><sup>TM</sup>** edition 2 is directly connected to the gateway and that the devices can be parameterized on site.

For this kind of commissioning a distinction must be made between two different situations.

#### 5.7.1 Fully Mounted RPI system

For a fully mounted and configured RPI system the configuration can be uploaded on the PC as described in Chapter 5.6.2. The parameter assignment is carried out according to **Chapter 6 "Parameter Assignment"** and is downloaded to the RPI device in question.

#### 5.7.2 Successive Assembly of the RPI Devices

The Power Rail, power supply, and gateways are mounted and the unconnected terminals of the RPI devices and the sensor and actuator cables are screwed together. This situation may arise, when KFD0-LGH dummy housings were originally installed which are later on replaced by RPI devices.

Commissioning takes place analogous with Chapter 5.6.1., however, no preplanned **PACT<sub>ware</sub><sup>TM</sup>** project is downloaded to the gateway. After an RPI device has been snapped on, it is automatically assigned the next free address by the gateway. The parameter assignment for this device can now be carried out. After that, the next device can be snapped onto the Power Rail, if required.

### 5.8 Configuration and Parameter Assignment via PROFIBUS DP V1

This method of configuration and parameter assignment can only be carried out using the KSD2-GW2-PRO Gateway for PROFIBUS DP V1 in conjunction with **PACT<sub>ware</sub><sup>TM</sup>** Edition 2 or with another FDT compatible human machine interface. To enable the gateway to communicate with a PC as PROFIBUS master class 2 via the external bus, it is necessary to integrate a communication Device Type Manager (DTM). This DTM enables **PACT<sub>ware</sub><sup>TM</sup>** to carry out the configuration and parameter assignment of the RPI system by means of an acyclic data exchange via the master class 2.

1. Set the transfer rate and the gateway addresses depending on the bus system using the pushbuttons. The information required for this procedure is given in Chapter 7.2 "Gateways for PROFIBUS DP" on Page 114.
2. Insert the communication DTM into the offline project.

### 5.9 Configuration and Parameter Assignment via PROFIBUS DP and GSD 0818p.gsd

Alternatively, the devices can be parameterized device by device using the GSD file. This procedure is described in Chapter 7.2 "Gateways for PROFIBUS DP" on Page 114 .

## 6 Parameter Assignment

### 6.1 Parameters of the RPI Modules

The individual RPI devices can be parameterized by means of both the human machine interface **PACT<sub>ware</sub><sup>TM</sup>** edition 2 or a different configuration tool. In the case of **PACT<sub>ware</sub><sup>TM</sup>** Device Type Managers (DTM) are available for each RPI device. As far as compatibility with other configuration tools is concerned, your local Pepperl+Fuchs sales office will be pleased to advise you.



Note

In this section the RPI-specific features of **PACT<sub>ware</sub><sup>TM</sup>** are discussed. A detailed description of the human machine interface **PACT<sub>ware</sub><sup>TM</sup>** edition 2 can be obtained from the Handbook **PACT<sub>ware</sub><sup>TM</sup>** edition 2. The handbook can be downloaded free of charge from <http://www.pepperl-fuchs.com/pa/accessories/pactware/main.html>.

#### 6.1.1 The **PACT<sub>ware</sub><sup>TM</sup>** Parameterization Window

In general, on the **PACT<sub>ware</sub><sup>TM</sup>** human machine interface, the screen is divided into two windows. The left window shows the project tree, while the right window shows the respective edit windows.

The DTM settings for each RPI device (see section 6.2) are carried out in a parameterization window.

##### 6.1.1.1 'Parameter' Tab

You can access all settable parameter values of the selected RPI devices via the 'Parameter' tab. Information that cannot be changed is displayed in light grey.

The data of this tab can be:

1. saved into a file
2. saved to the device.

On clicking the '**Save to device**' button **PACT<sub>ware</sub><sup>TM</sup>** edition 2 after requesting sets up a connection to the selected device and loads the data to this device.



Note

Using *Save to file* or *Save to device* the data of the activated device or the COM driver is stored, whereas the remaining data of the project is not stored.

This means that in a project, consisting of a COM driver and devices, the changed settings must be downloaded twice - for the COM driver and for the device separately.



Note

In addition, the overall project should be stored on data carriers by using 'Save project'.

##### 6.1.1.2 'Properties' Tab

The individual DTMs offer information on themselves and on the devices to be edited using these DTMs. The 'Properties' tab contains the 'Device Info' and 'Description' tabs.

###### 'Device Info'

'Device Info' provides unchangeable information on the selected device. The following information can be obtained from the card:

- the data source
- the time when the module specific data was generated
- the time when the last change was made
- the device type
- and the description of the device

Additional information is read out of the device as soon as a first connection to the RPI system is set up:

- Serial number,
- Software version
- Hardware version

## 'Description'

Using 'Description' you can store data which is specific to a measuring point, e.g.: tag data and tag name.



Note

This information is only stored in the project on the data carrier not in the individual RPI devices.

## 6.2 Editing a Project

A project in **PACTware**<sup>TM</sup> presents the structure of your RPI system. By means of the connection of your field devices to the RPI interface modules, the allocation of the field devices to both the RPI gateways and the corresponding address on the external bus is documented.

The same applies to the underlying service network, provided that the RS 485 service interfaces of your gateways have been wired.

The project is configured using the various Device Type Managers (DTM). DTMs for devices of other manufacturers can be used apart from the DTMs offered by Pepperl+Fuchs, as long as they conform to the FDT (Field Device Tool) standard.

A typical project is structured as follows:

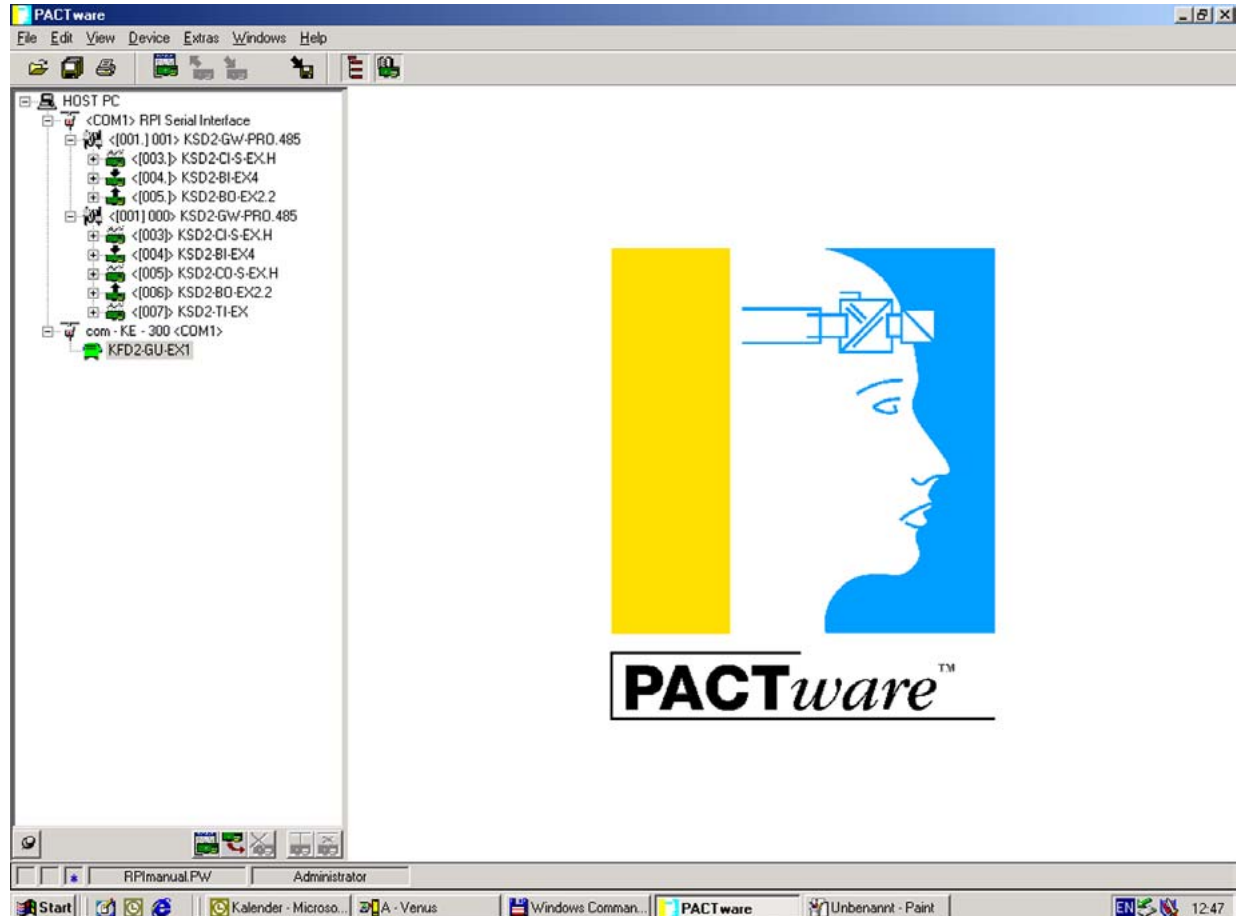

Figure 6.1: Projekt structure

## 6.2.1 Opening a Project

An existing project is opened using the menu item *<Open file>* in the menu bar or the tool bar button  in the tool bar .

## 6.2.2 New Project

Open a new project using the menu item *<New>* in the menu bar and then store it under the name you have chosen.

The project is structured as a tree based on the preset entry 'HOST IBM-PC' in the following order of succession:

1. COM driver (RPI Serial interface)
2. First gateway
3. Added to the first gateway (optionally): second gateway for redundant communication with the control system
4. RPI devices, added to the first gateway
5. Next gateway for additional RPI string, added to COM driver gateways and devices
6. Next COM driver, added to HOST IBM-PC, e.g.: for HART communication or connection of non-RPI devices

## 6.2.3 Adding Components

There are three ways to edit a project in the project window:

1. Click onto the desired position in the project tree using the right mouse button and select the menu item *<Add device>*.
2. Click onto the desired position in the project tree using the left mouse button and then onto *<Add>* down on the left.
3. Select *<Project>* in the menu bar and then *<Device catalogue>* or press function key F3 after which the device catalogue appears in the edit window. It contains all the installed Device Type Managers in a Windows<sup>®</sup>-Explorer representation. By highlighting the desired position in the project tree and then double clicking onto a device, the latter is pasted into the project.

If you select options 1 or 2, a selection window offers you only those options, that can be pasted to the selected position. Click onto the desired Device Type Manager in the selection window and confirm your selection using the *<OK>* button or double click the desired Device Type Manager.

If you wish to use the device catalogue (point 3 given above), the screen separates into three parts.

The left part shows the project tree. The middle part shows the DTM components structured according to their functions and installed on your PC using **PACT<sub>ware</sub><sup>TM</sup>**. The right part lists the entire device catalogue.



In general the following applies to projecting: Only those devices can be selected from the device catalogue, whose model numbers correspond to the devices used in the RPI system. **PACT<sub>ware</sub><sup>TM</sup>** does not permit the connection of Device Type Managers, unless they are useful on the relevant position in the project tree.

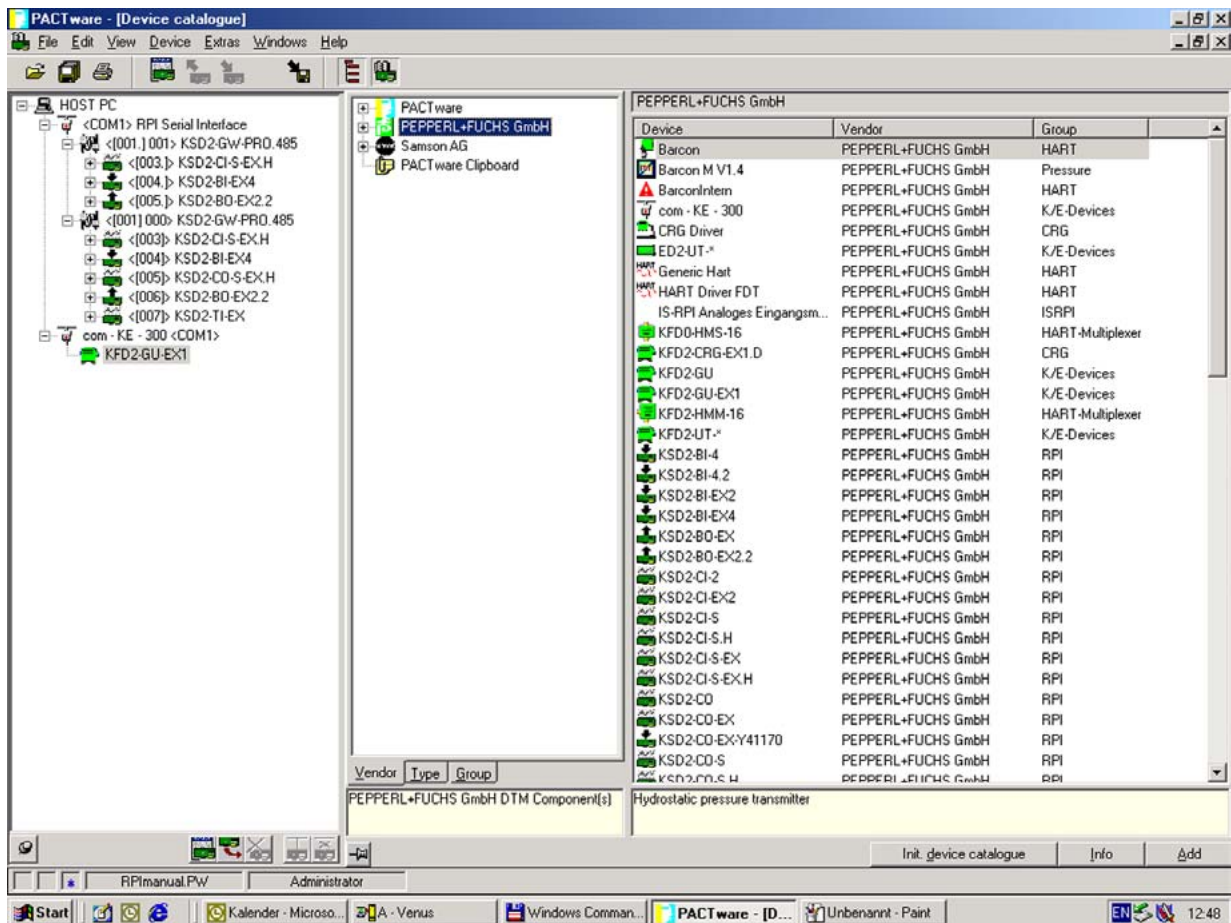

Figure 6.2: Device catalogue



Note

Make sure to activate (i.e. highlight grey/blue) exactly that level in the left column which can be used to project your component.

This means that, if you wish to project a COM driver, the HOST IBM PC must be activated. Similarly, if you wish to project an RPI device, an RPI gateway should be activated.

If this is not the case, an error message appears.

**PACTware™** adds a device and assigns this device an address for the RPI internal bus, simultaneously. The first gateway is generally assigned Number 1, the second gateway Number 2, and the first RPI device is assigned Number 3. A gateway can communicate with a maximum of 125 RPI devices (addresses [003] to [127]).

## 6.2.4 Deleting Components



Attention

Before you delete a device from the project tree make sure that you selected the correct device(s). There is no undo function available.

There are two ways to delete a device from the project tree:

1. Click onto the device that you wish to delete from the project tree using the right mouse button and select <Delete Device>.
2. Click onto the device that you wish to delete from the project tree using the left mouse button and then onto the <Delete> button down on the left.

## 6.3 Parameterizing Individual Components

In order to edit an RPI device in PACT<sup>ware</sup>™:

1. click onto the component that you wish to edit in the project tree using the right mouse button and select **Offline Parameter**, or
2. double click the component that you wish to edit in the project tree, or
3. click onto the component that you wish to edit in the project tree using the left mouse button and then click the **Edit** button in the project window down on the right, or
4. click onto the component that you wish to edit in the project tree using the left mouse button and then press function key F5.

Now the offline parameterization window opens, displaying the tabs 'Device Info', 'Description' and 'Parameter'.

### 6.3.1 Parameters of the COM Drivers

#### 6.3.1.1 RPI Serial Interface

The <Parameter> tab is used to set the serial interface together with the port designation on your PC and the baud rate.

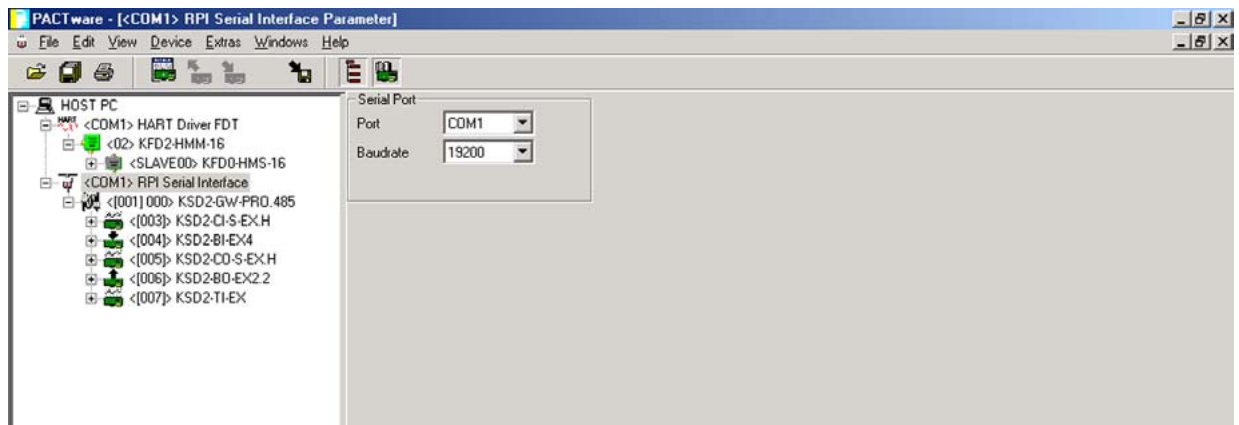

Figure 6.3:Parameterize the serial interface

Serial interface

Port: Setting the designation of the serial port on the PC/notebook.

Baud rate: Must correspond to the set baud rate on the PC/notebook.

#### 6.3.1.2 HART Protocol Driver

The <Parameter> tab is used to set the serial interface together with the port designation on your PC, the baud rate as well as a number of HART parameters. Detailed information can be obtained from the HART Multiplexer KFD2-HMM-16 Handbook .

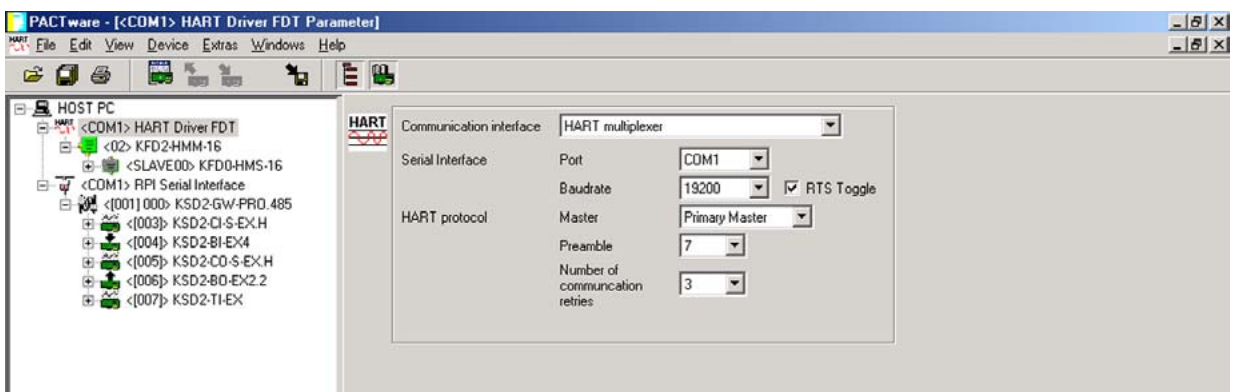

Figure 6.4:Parameterizing the HART protocol driver

### 6.3.1.3 Device Type Managers for Non-RPI Devices

DTM for field devices or interface modules, not relating to the RPI system, can likewise be embedded into the project tree. To do this, one needs suitable communication drivers. These must conform to the FDT standard. For more detailed information, please refer to the handbook of the relevant device.

### 6.3.2 Gateway Parameters

#### 6.3.2.1 MODBUS RTU

The tab for the gateway parameters contains the `Communication` and the `Password/Panel` tab. The following four parameters must be set for the communication of the gateway:

- Address on the MODBUS: 0 ... 127
- Baud rate: 1,200 ... 57,600 bit/s
- Parity/stop bit: no/1 stop bit - odd/1 stop bit - even/1 stop bit - no/2 stop bits
- Address of the parameterization interface: 0 ... 127, as set on the gateway

The section `Internal Communication` indicates the `Operating Mode` and the `Internal Cycle Time`. However, they cannot be changed.

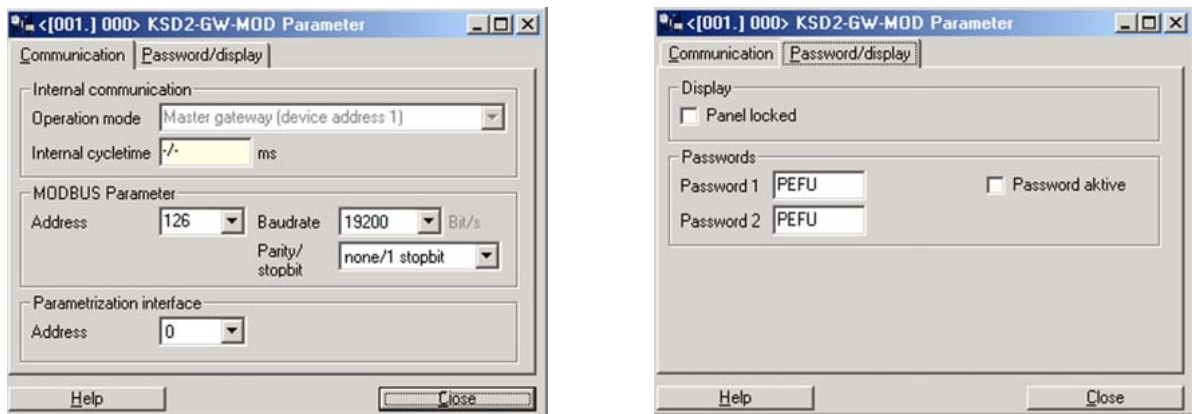

Figure 6.5: Parameterizing the Modbus RTU gateway

The `Password/Panel` tab enables you to lock the operating unit and to activate the passwords by checking the respective boxes.

#### 6.3.2.2 MODBUS Plus

The tab for the gateway parameters contains the tabs `Communication` and `Password/Panel`. Two parameters have to be set for the communication of the gateway:

- Address on the MODBUS: 0 ... 127
- Address of the parameterization interface: 0 ... 127, as set on the gateway

The section `Internal Communication` indicates the `Operating Mode` and the `Internal Cycle Time`. However, they cannot be changed.

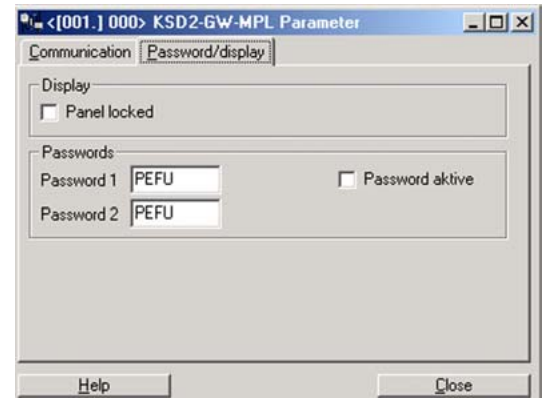
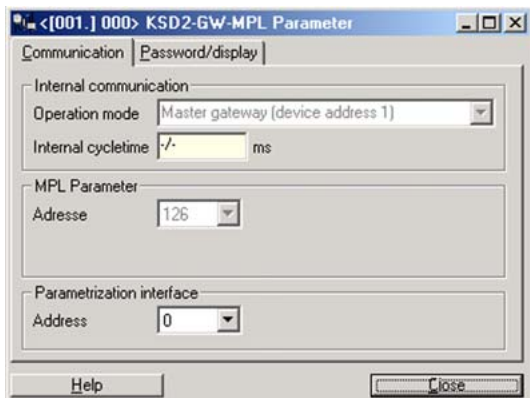

Figure 6.6:Parameterizing the Modbus Plus Gateway

The `Password/Panel` tab enables you to lock the operating unit and to activate the passwords by checking the respective boxes.

### 6.3.2.3 PROFIBUS DP and DP V1

The tab for the gateway parameters contains the tabs `Communication` and `Password/Panel`. Two parameters have to be set for the communication of the gateway.

- Address on the PROFIBUS: 0 ... 127
- Address of the parameterization interface: 0 ... 127, as set on the gateway.

The section `Internal Communication` indicates the `Operating Mode` and the `Internal Cycle Time`. However, they cannot be changed.

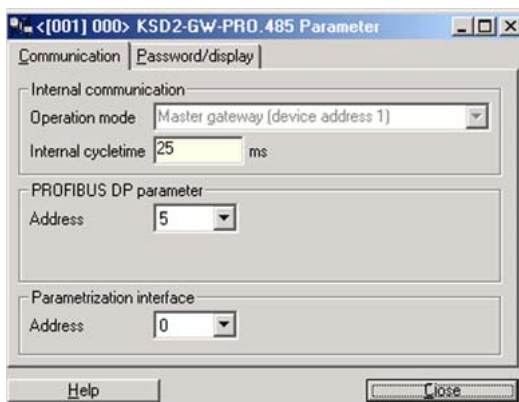

Figure 6.7:Parameterizing the PROFIBUS DP gateway

The `Password/Panel` tab enables you to lock the operating unit and to activate the passwords by checking the respective boxes.



Note

The device address 127 is reserved for a specific PROFIBUS service and cannot be set on the gateways.

### 6.3.2.4 ControlNet

The tab for the gateway parameters contains the tabs `Communication` and `Password/Panel`. Two parameters have to be set for the communication of the gateway.

- Address on the ControlNet bus: 0 ... 127
- Address of the parameterization interface: 0 ... 127

The section Internal Communication indicates the Operating Mode and the Internal Cycle Time. However, they cannot be changed.

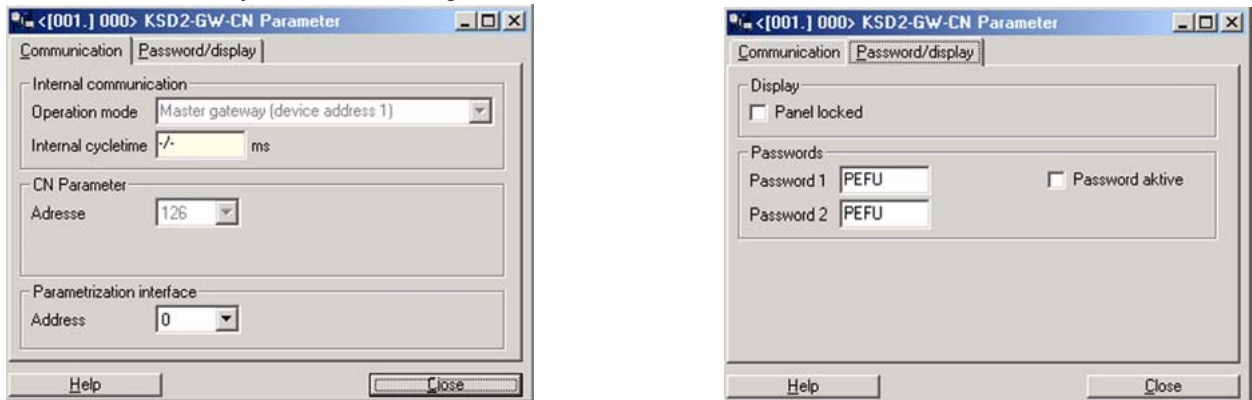

Figure 6.8: Parameterizing the ControlNet gateway

The Password/Panel tab enables you to lock the operating unit and to activate the passwords by checking the respective boxes.

### 6.3.3 Isolated Switch Amplifier

The Parameter tab contains both device specific and channel specific parameters.

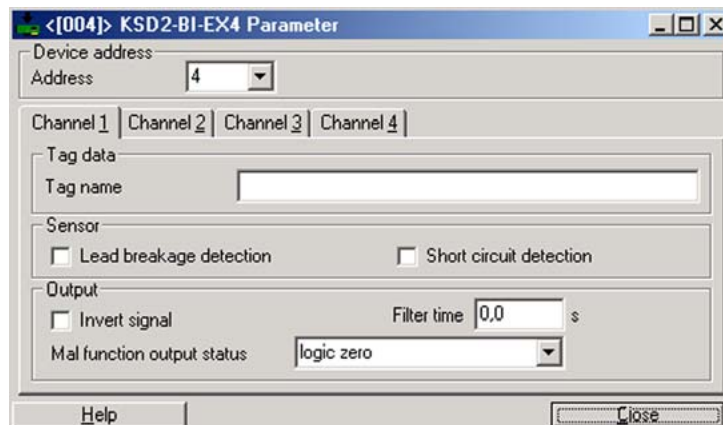

Figure 6.9: Parameterizing KSD2-BI-...

Device Address:	The entered address must be identical with the address set on the relevant device.
Tag Data:	
Tag Name:	A description with a maximum of 32 characters can be entered into the box in order to ensure rapid and secure allocation.
Sensor:	
Lead breakage detection:	The sensor lead is monitored for lead breakage.
Short circuit detection:	The sensor lead is monitored for short circuits.
Output:	
Invert Signal:	The input signal is inverted and transferred to the bus.
Filter Time:	Filter time signifies that input pulses shorter than the filter time are suppressed.
Malfunction output status:	By means of the settings <i>Downscaled</i> , <i>Upscaled</i> or <i>Hold Last Value</i> the signal transferred to the control system in the error case is determined according to the application.

## 6.3.4 Current Frequency Converter, Batch Controller

The Parameter tab contains both device specific and channel specific parameters.

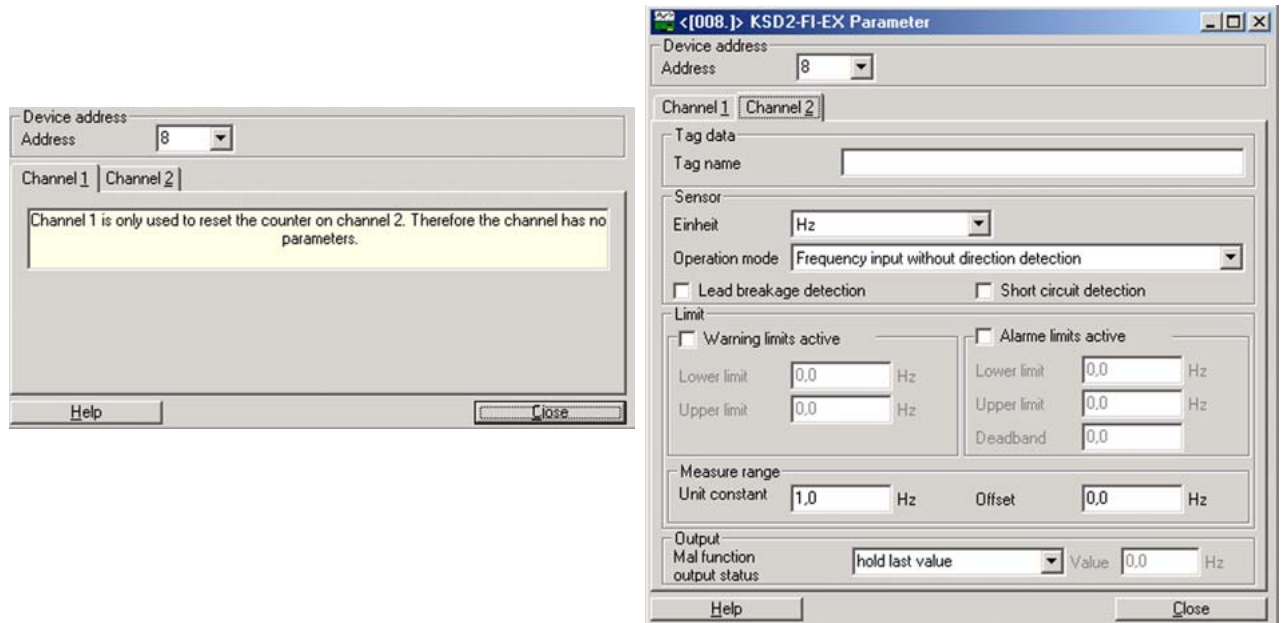

Figure 6.10: Parameterizing KSD2-FI...

Device Address:	The entered address must be identical with the address set on the relevant device.
Tag Data:	
Tag Name:	It allows you to type in a descriptor (tag name) which may contain up to 32 characters. This is helpful for larger projects to identify the devices clearly.
Sensor:	
Unit:	In this box the input signal can be assigned a physical unit.
Operating Mode:	Four different operating modes can be selected. Frequency input with or without rotation direction monitoring, counter input with or without rotation direction monitoring.
Lead breakage detection:	The sensor lead is monitored for lead breakage.
Short circuit detection:	The sensor lead is monitored for short circuits.
Limit Values:	
Warning limits active:	If you check the left box by clicking into it, you activate the warning limits. Now Lower Limit and Upper Limit turn from grey to black. The limit values are entered into the boxes on the right hand side.
Alarm limits active:	If you check the left box by clicking into it, you activate the alarm limits. Now Lower Limit, Upper Limit and Hysteresis turn from grey to black. The limit values are entered into the boxes on the right hand side.

Measuring Range:

Unit Constant:

In the operating mode frequency input the unit constant allows a conversion from Hz to another physical unit (e.g. rpm for rotational speed, m<sup>3</sup>/h for flow etc.) This is necessary, when the higher level system requires other units than Hz. The unit constant is defined as follows:

Example: At an input frequency of 100 Hz, the output value is to be 20. This results in a unit constant of 5. At a counter reading of 2500 the transferred value is to be 125. This leads to a unit constant of 20.

Offset:

Enter value for Offset.

Output:

Malfunction output status:

By means of the settings `As Input` or `Hold Last Value` the signal transferred to the control system in the error case is determined according to the application. For the setting `As input` a value should be entered in the box on the right hand side.

### 6.3.5 Solenoid Drivers

The Parameter tab contains both device specific and channel specific parameters.

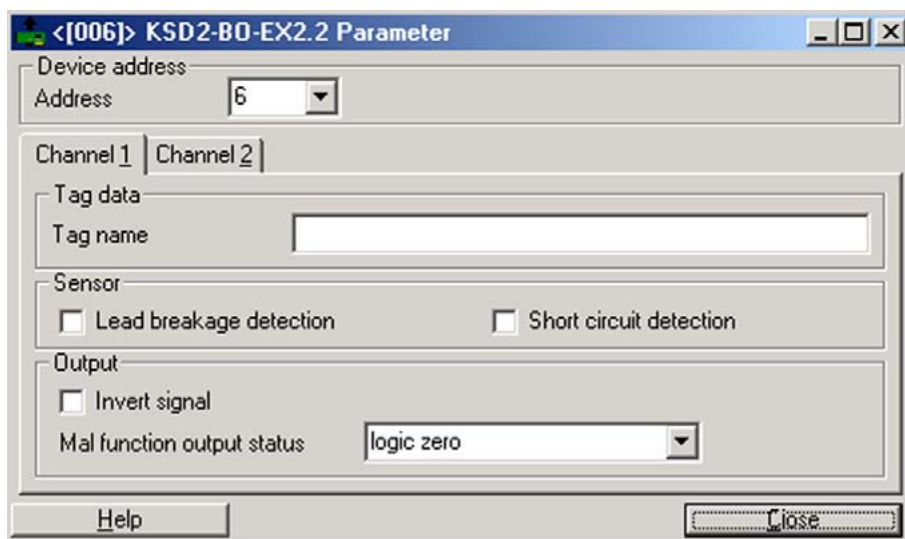

Figure 6.11:Parameterizing KSD2-BO-...

Device Address:

The entered address must be identical with the address set on the relevant device.

Tag Data:

Tag Name:

It allows you to type in a descriptor (tag name) which may contain up to 32 characters. This is helpful for larger projects to identify the devices clearly.

Sensor:

Lead breakage detection:

The sensor lead is monitored for lead breakage..

Short circuit detection:

The sensor lead is monitored for short circuits.

Output:

Invert Signal:

The input signal is inverted and transferred to the bus.

Malfunction Output Status:

By means of the settings `Downscaled`, `Upscaled` or `Hold Last Value` the signal transferred to the control system in the error case is determined according to the application.

## 6.3.6 Relay Modules

The Parameter tab contains both device specific and channel specific parameters.

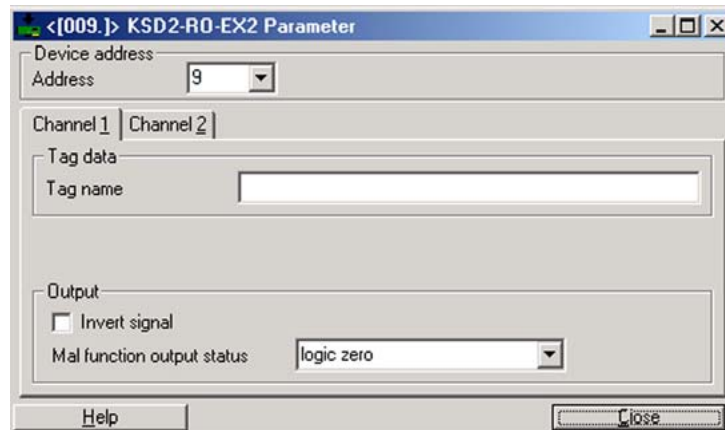

Figure 6.12:Parameterizing KSD2-RO-...

- Device Address: The entered address must be identical with the address set on the relevant device.
- Tag Data:
- Tag Name: It allows you to type in a descriptor (tag name) which may contain up to 32 characters. This is helpful for larger projects to identify the devices clearly.
- Output:
- Invert Signal: The input signal is inverted and transferred to the bus.
- Malfunction Output Status: By means of the settings *Downscaled*, *Upscaled* or *Hold Last Value* the signal transferred to the control system in the error case is determined according to the application.

## 6.3.7 Transmitter Power Supplies

The Parameter tab contains both device specific and channel specific parameters..

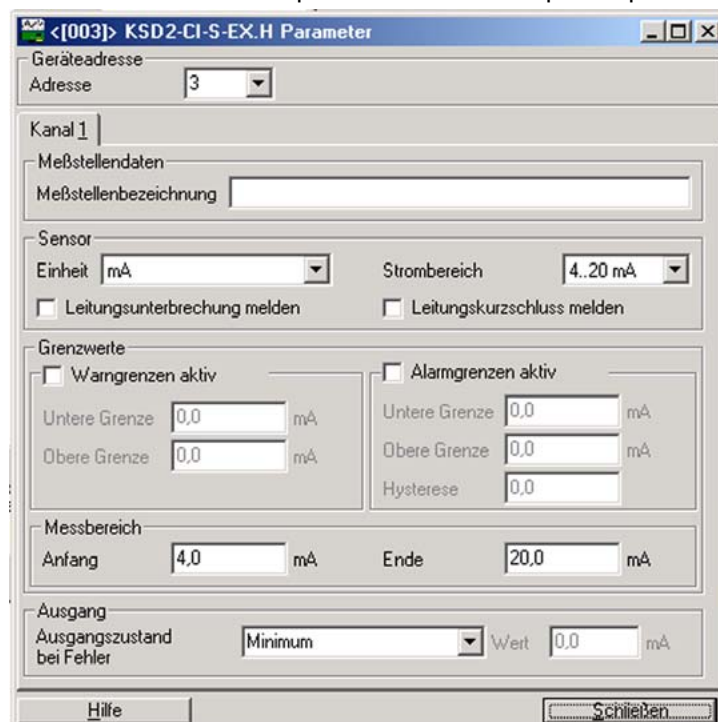

Figure 6.13:Parameterizing KSD2-CI-...

Date of issue 05/27/03

Device Address:	The entered address must be identical with the address set on the relevant device.
Tag Data:	
Tag Name:	It allows you to type in a descriptor (tag name) which may contain up to 32 characters. This is helpful for larger projects to identify the devices clearly.
Sensor:	
Unit:	In this box the input signal can be assigned a physical unit.
Current Range:	The zero point of the input signal is defined by selecting the current range.
Lead breakage detection:	The sensor lead is monitored for lead breakage..
Short circuit detection:	The sensor lead is monitored for short circuits.
Limit Values:	
Warning limits active:	If you check the left box by clicking into it, you activate the warning limits. Now <code>Lower Limit</code> and <code>Upper Limit</code> turn from grey to black. The limit values are entered into the boxes on the right hand side..
Alarm Limits active:	If you check the left box by clicking into it, you activate the alarm limits. Now <code>Lower Limit</code> , <code>Upper limit</code> and <code>Hysteresis</code> turn from grey to black. The limit values are entered into the boxes on the right hand side.
Measurement Range	
Start:	The start value needs to be entered in order to be able to scale the measured value.
End:	The final value needs to be entered in order to be able to scale the measured value. Example: The current range is 4 ... 20 mA and the measuring range is 1 ... 5 bar. The measured value is transferred via the external bus with a factor of 100, i.e., for instance at 2.5 bar a value of 250 is transferred.
Output	
Malfunction Output Status:	By means of the settings <code>As Input</code> , <code>Minimum</code> , <code>Maximum</code> or <code>Hold Last Value</code> the signal transferred to the control system in the error case is determined according to the application. For the setting <code>As Input</code> a value should be entered in the box on the right hand side.

## 6.3.8 Temperature Converter

The Parameter tab contains both device specific and channel specific parameters.

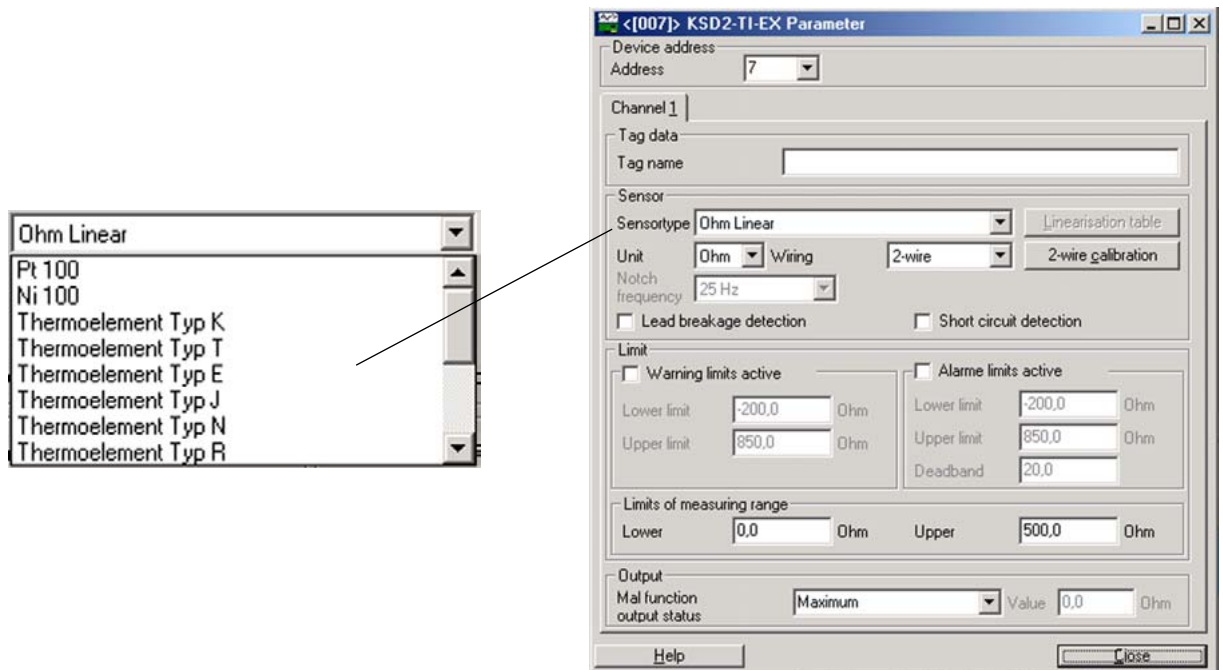

Figure 6.14: Parameterizing KSD2-TI-...

Device Address:

The entered address must be identical with the address set on the relevant device.

Tag Data:

Tag Name:

It allows you to type in a descriptor (tag name) which may contain up to 32 characters. This is helpful for larger projects to identify the devices clearly.

Sensor:

Sensor Type:

In this menu you can select a sensor from a list of various sensor types.

Connection Method:

The connection method of the sensor to the RPI module should be set using this list box.

Unit:

In this box the input signal can be assigned a physical unit..

Linearization Table:

Here you can enter values into a table (Ohm/Temperature)

Lead breakage detection:

The sensor lead is monitored for lead breakage.

Short circuit detection:

The sensor lead is monitored for short circuits.

Limit Values:

Warning limits active:

If you check the left box by clicking into it, you activate the warning limits. Now Lower Limit and Upper Limit turn from grey to black. The limit values are entered into the boxes on the right hand side..

Alarm limits active:

If you check the left box by clicking into it, you activate the alarm limits. Now Lower Limit, Upper Limit and Hysteresis turn from grey to black. The limit values are entered into the boxes on the right hand side.

Measuring Range:

Start:

The start value needs to be entered in order to be able to scale the measured value.

End:

The end value needs to be entered in order to be able to scale the measured value.

Output:

Invert Signal:

Malfunction Output Status:

The input signal is inverted and transferred to the bus.

By means of the settings *As Input*, *Minimum*, *Maximum* Or *Last Value* the signal transferred to the control system in the error case is determined according to the application. For the setting *As Input* a value should be entered in the box on the right hand side.

### 6.3.9 Converter for Voltage

The Parameter tab contains both device specific and channel specific parameters.

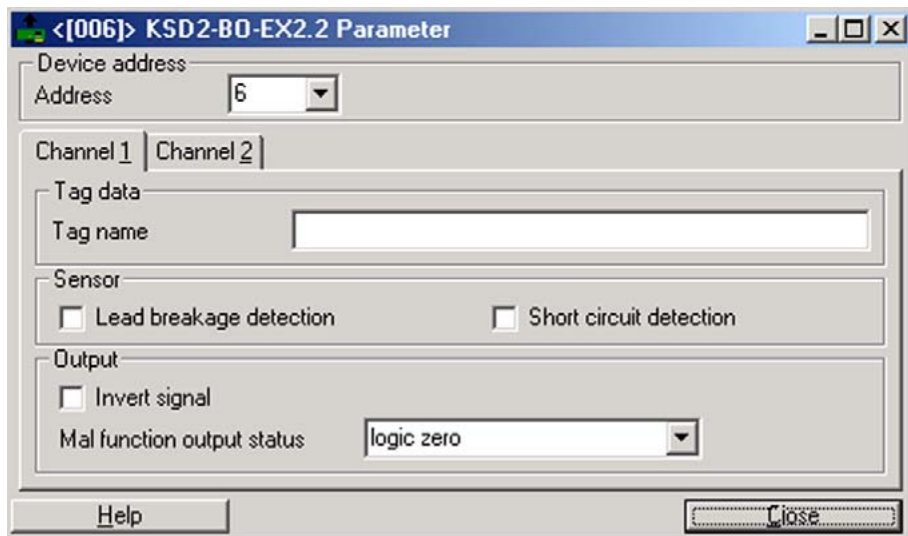

Figure 6.15:Parameterizing KSD2-VI

Device Address:

The entered address must be identical with the address set on the relevant device.

Tag Data:

Tag Name:

It allows you to type in a descriptor (tag name) which may contain up to 32 characters. This is helpful for larger projects to identify the devices clearly.

Sensor:

Unit:

In this box the input signal can be assigned a physical unit..

Voltage Range:

The zero point of the input signal is defined by selecting the voltage range.

Lead fault detection:

The sensor lead is monitored for lead breakage.

Limit Values:

Warning limits active:

If you check the left box by clicking into it, you activate the warning limits. Now *Lower Limit* and *Upper Limit* turn from grey to black. The limit values are entered into the boxes on the right hand side..

Alarm limits active:

If you check the left box by clicking into it, you activate the alarm limits. Now *Lower Limit*, *Upper Limit* and *Hysteresis* turn from grey to black. The limit values are entered into the boxes on the right hand side.

Measuring Range:	
Start:	The start value needs to be entered in order to be able to scale the measured value.
End:	The end value needs to be entered in order to be able to scale the measured value.
Output:	
Invert Signal:	The input signal is inverted and transferred to the bus.
Malfunction Output Status:	By means of the settings <i>As Input, Minimum, Maximum Or Hold Last Value</i> the signal transferred to the control system in the error case is determined according to the application. For the setting <i>As Input</i> a value should be entered in the box on the right hand side.

### 6.3.10 Analogue Driver/Repeater

The Parameter tab contains both device specific and channel specific parameters..

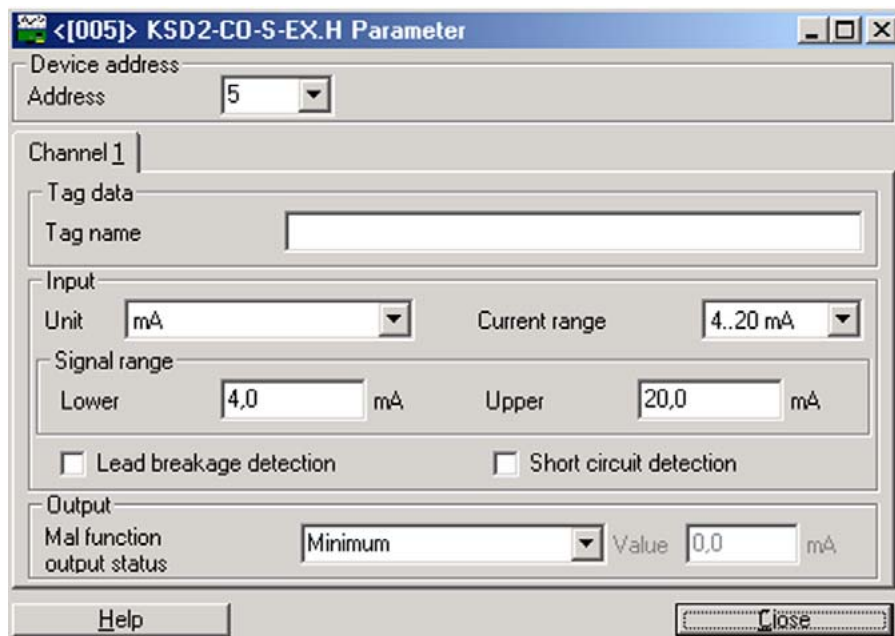

Figure 6.16:Parameterizing KSD2-C0-...

Device Address:	The entered address must be identical with the address set on the relevant device.
Tag Data:	
Tag Name:	It allows you to type in a descriptor (tag name) which may contain up to 32 characters. This is helpful for larger projects to identify the devices clearly.
Input:	
Unit:	<b>In this box the input signal can be assigned a physical unit.</b>
Current Range:	The zero point of the input signal is defined by selecting the current range.
Lead breakage detection:	The sensor lead is monitored for lead breakage.
Short circuit detection:	<b>The sensor lead is monitored for short circuits.</b>

### Measuring Range

**Start:** The start value needs to be entered in order to be able to scale the measured value.

**End:** The end value needs to be entered in order to be able to scale the measured value.

**Example:**

The current range is 4 ... 20 mA and the measuring range is 1 ... 5 bar. The measured value is transferred via the external bus with a factor of 100, i.e., for instance at 2.5 bar a value of 250 is transferred.

### Output

**Malfunction Output Status:** By means of the settings *As Input*, *Maximum*, *Minimum* or *Hold Last Value* the signal transferred to the control system in the error case is determined according to the application. For the setting *As Input* a value should be entered in the box on the right hand side.

## 6.4 Downloading Project Data into the Gateway

Having configured the RPI system and generated the project offline on the PC, the data is downloaded to the gateway. The PC/notebook and the gateway are connected as follows:

1. The PC is connected to the RS232 service interface of the gateway via the RS232 serial interface and the K-ADP2 adapter.
2. The PC is connected to the RS485 service interface of the gateway via a plug-in card with RS485 or via a RS232/RS485 converter and a K-ADP4 adapter. The adapter is not required if there is a fixed wiring between the RS485 service interface and the PC.
3. In the case of PROFIBUS DP V1 gateway KSD2-GW2-PRO it is possible to integrate the PC as class 2 master into the PROFIBUS and to transfer the data directly to the gateway via the bus.

The red LEDs of both RPI devices and gateways extinguish after the project data has been transferred to the gateway, and as soon as the configuration is identical with the transferred parameter data and all field devices are connected to the RPI system correctly.

The 'External bus - fault' LED may continue to flash on the gateway, if the bus master is not yet active.

If a redundant gateway is used, the data must also be transferred to the second gateway, as stated above.

Usually, on downloading the parameterization data the commissioning of the RPI system ends, since the integration into the higher-level bus system is carried out using process control technique. The information required for this procedure is given in **Chapter 7 "Integration into the Higher-Level Bus System"**.

Verification of the RPI system can also be carried out without a higher level bus system. Information on the various options is provided in **Chapter "Monitoring, Simulating Measured Values and Error Handling"**.

## 6.5 Commissioning the Gateways and the External Bus System

The commissioning procedure strongly depends on the bus system used, e.g. PROFIBUS DP, MODBUS RTU, MODBUS Plus or ControlNet, as well as on the control system used.



Note

Important information on commissioning the external bus system and the control system will also be found in the technical documentation of your control system and in **Chapter 7 "Integration into the Higher-Level Bus System"**

Prior to commissioning the bus addresses and if necessary the bus termination must be reset. The gateway automatically adjusts to the transfer rate prescribed by the bus master.

## 7 Integration into the Higher-Level Bus System

### 7.1 General Notes on Operating the Gateways

This chapter provides information on all functions and communications which are identical for all gateways.

#### 7.1.1 Gateways of Type KSD2-GW-...

The construction and operation of the KSD2-GW-... gateways, using the controls on the front of the devices is similar for all types. They only differ in that they contain either RS232 or RS485 service interfaces.



In the case of gateways with RS232 service interfaces, the terminal connection and the jack must not be used simultaneously since simultaneous data transfer is not possible on the internal bus.

Gateways with RS485 service interfaces have no jack. Detailed information on the differences between gateways for PROFIBUS, Modbus RTU, Modbus Plus and ControlNet is provided from Chapter 7.2 onwards. Chapter 5 "Configuring and Commissioning the RPI System" provides an explanation of the RPI system configuration via the gateway pushbuttons and of the menu structure.

#### Construction of the devices:

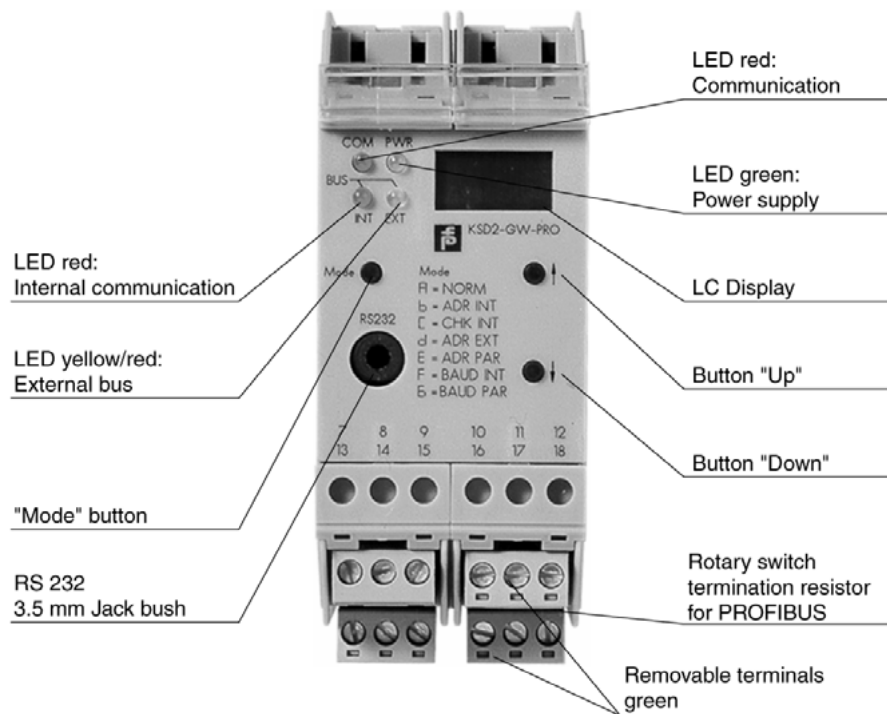

Figure 7.1: Front View of the KSD2-GW-... gateways

## 7.1.2 Gateways of Type KSD2-GW2-..

Gateways of type KSD2-GW2-... have both RS232 and RS485 service interfaces, a double-row LC-Display and four buttons for menu prompting. The RS485 interface is connected via the terminals 7, 8 and 9 whereas the RS232 interface is designed as a 3.5 mm jack plug located on the front of the device. Since both interfaces are independent they can be used simultaneously. Detailed information is given in Chapter 7.2 "Gateways for PROFIBUS DP". Chapter 5 "Configuring and Commissioning the RPI System" provides an explanation of the RPI system configuration by means of the gateway pushbuttons and of the menu structure.

### Construction of the devices:

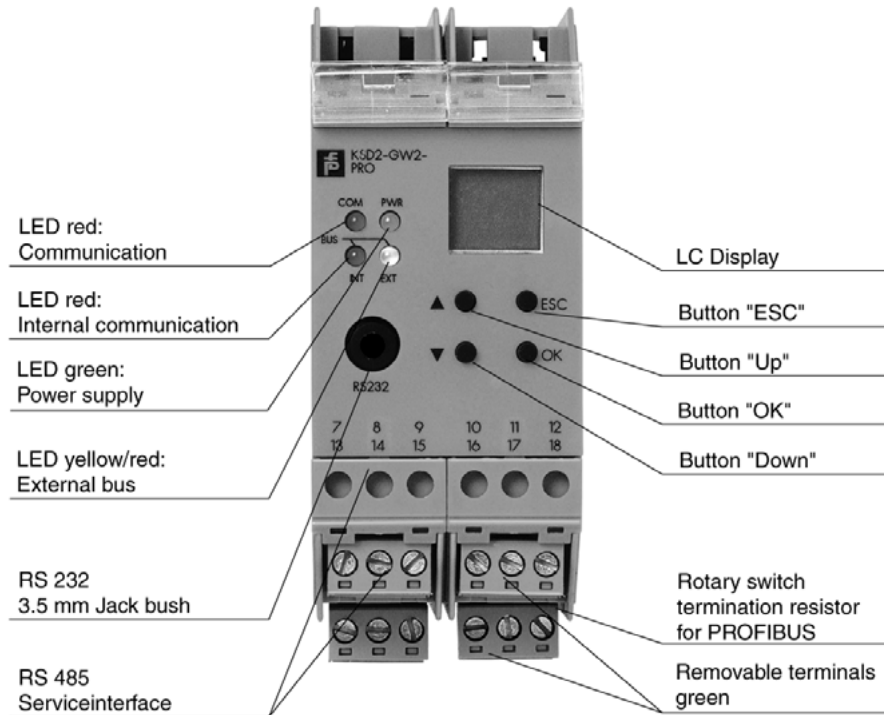

Figure 7.2: Front view of the KSD2-GW2-... gateways

**7.1.3 Data Formats**

Analogue values of the different RPI modules or values for the configuration and parameterization of the system can be transmitted either in signed integer (integer numbers) or in floating point format.

**Floating-point arithmetic**

In the case of both RPI-internal communication and communication to the host computer, the floating point values are transmitted with single precision in accordance with "IEEE 754 short real number". The values are stored at 4 bytes (=32 bit) and the memory block is classified as follows:

Bit position	Meaning
31	Sign bit
30-23	Exponent (with a BIAS of 127)
22-0	Mantissa

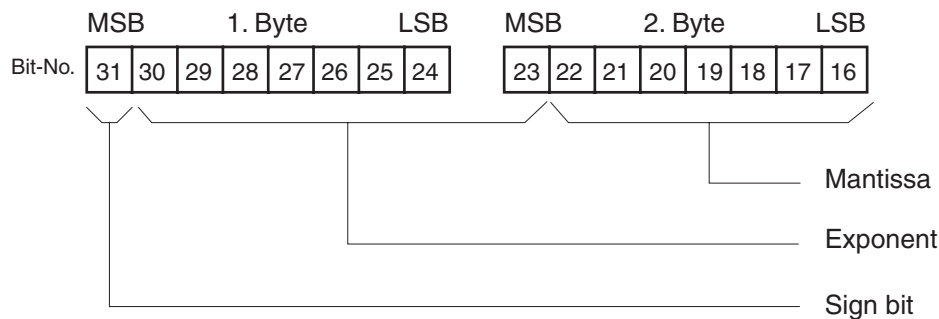

The sign bit 31 indicates whether the stored number be positive (s=0) or negative (s=1). The 8 exponent bits constitute the exponent. However, a BIAS of 127 has to be subtracted from each exponent. In other words, in the exponent a bit sequence of 111 1111 (corresponds to 127) stands for exponent 0. The 23 mantissa bits represent the 23 fractional digits of a 24-digit binary number. The first digit before the dual point is always 1. It is not stored.

The following table provides examples of "simple" floating point numbers.

Number	Binary notation (Sign, Exp., Mantissa)	Meaning
1.0	0011 1111 1000 0000 0000 0000 0000 0000	+/127-127/1.00 => 2 <sup>0</sup> * 1.00 = 1
5.0	0100 0000 1010 0000 0000 0000 0000 0000	+/129-127/1.25 => 2 <sup>2</sup> * 1.25 = 5
-13.0	1100 0001 0101 0000 0000 0000 0000 0000	- /130-127/1.625 => 2 <sup>3</sup> * 1.625 = -13
16.5	0100 0001 1000 0100 0000 0000 0000 0000	+/131-127/1.03125 => 2 <sup>4</sup> * 1.03125 = 16.5
125.635	0100 0010 1111 1011 0100 0101 0000 0000	+/133-127/1.9630469 => 2 <sup>6</sup> * M = 125.635

**Integer format**

2 byte are required to transmit the measured values in the signed integer format. Likewise, 2 byte are required in order to represent numbers from -32.768 to +32.767 in the signed integer format. In order to achieve a more accurate transfer of the data, temperature measurement values are transferred with a factor of 10 whereas current input and output values are transferred with a factor of 100. As a result, the transfer of the numerical value of 1560 leads to a measured value of 156.0 °C for temperature measurements or 15.6 mA for mA-measurements.

### 7.1.4 Status Information of Process Data

Profibus, Modbus RTU, Modbus Plus and ControlNet can also transfer the status of process values.

Depending on the status, the transferred value is either reprocessed or rejected. The space occupied by the status information per channel of a device is 1 byte for the PROFIBUS protocol, 1 register for Modbus RTU, 1 word for Modbus Plus, and 1 word for ControlNet 1.

During the transfer of analogue values, bit 0 of the low byte (Dat) is always set to 0. Binary signals are transferred via bit 0 of the low byte (Dat).

Bits GW1 and GW2 are reserved for limit value monitoring.

CD1 to CD3 code any errors which have occurred.

Q1 and Q2 provide information on the signal quality.

The messages shown in the table below are generated instantaneously.

Meaning	GW2	GW1	CD3	CD2	CD1	Q2	Q1	Dat
Good							0	0
Not certain						0	1	0
Bad			0	0	0	1	0	0
Good, no error			0	0	0	0	0	0
Measurement range exceeded/fallen short			0	1	1	0	1	0
Simulated measured value			1	0	1	0	1	0
Reserved			1	1	0	0	1	0
Configuration error			0	0	1	1	0	0
RPI device error			0	1	0	1	0	0
Field device error			1	0	0	1	0	0
No communication (last good value)			1	0	1	1	0	0
No limit value reached	0	0						0
Lower limit value fallen short	0	1						0
Upper limit value exceeded	1	0						0

### 7.1.5 Operation with a Redundant Gateway

Operation with redundant gateways increases the availability of the system. The gateway that is active in normal operation must have the RPI address 1, whilst the redundant gateway must have the RPI address 2.

The prerequisite for the operation of a system with a redundant gateway, is that the configuration data for each RPI device is stored in a file in the current project directory.

The following describes the installation procedure that is necessary in the case of a gateway newly delivered from the manufacturer..

If this not the case, connect the Modbus gateway alone to a 24 V DC supply and depress the mode button in mode A (for KSD2-GW-... ) for longer than 3 s or depress the OK button in the 'Teach-in' service menu (for KSD2-GW2-...). This causes the current configuration (here: no device) to be taught-in.

In the following it is assumed that the RPI devices are pre-configured and mounted on the Power Rail. If this is not the case, then when the active gateway has been installed (step 1) the RPI devices must be addressed. The information required for this procedure is given in Chapter 5 'Configuration' and in Chapter 6 'Parameter Assignment'.

The following sequence should then be carried out:

1. Mount a gateway on the Power Rail and set the RPI address of this gateway to 1 (active gateway).
2. Teach in the current configuration via mode A or via the 'Teach-in' menu.
3. Load the project into the gateway (download) using the **PACT<sub>ware</sub>**<sup>TM</sup> software or transmit the configuration and parameterization data by means of Profibus DP V1, as described in Chapter 6.4 "Downloading Project Data into the Gateway" .
4. Mount the 2nd gateway on the Power Rail and set the RPI address of this gateway to 2 (redundant gateway).
5. Connect the PC to the redundant gateway and then repeat steps 2 and 3 for the redundant gateway.



**Note**

The active and the redundant gateway must receive different addresses for the PROFIBUS.

If the project has been downloaded into the redundant gateway, the system is ready for redundant operation.

When both gateways have been configured, the type and method of switching from the active to the redundant gateway must be established. This is achieved by setting the modes for the master of the fieldbus. The following modes can be set:

Value	Description
00h	Automatic switch-over to redundant gateway, in the event of the active gateway becoming defective
01h	Like 00, but also in the event of errors in the communication with the host
02h	Switch-over to the redundant gateway by the host (see gateway diagnosis)
03h	Switch-over of the passive gateway into the active mode

The active gateway (master) is set to 01 and the redundant gateway is set to 03 as standard. The advantage of this setting is that, in the event of an error after which the defective gateway is replaced, the gateway which is given the internal address 1 is always active.

### 7.1.6 Exchanging a Gateway

The addresses and parameters for the new gateway are set via PC and the **PACT<sub>ware</sub>**<sup>TM</sup> edition 2 human machine interface. Normal operation is resumed. A status information on the elimination of the fault is transmitted via the external bus.

### 7.1.7 Exchanging a Gateway - External Bus Redundant

If the system is redundant, due to the use of 2 gateways and two external bus branches, one gateway is defined as active (priority) and the other as redundant.

If one external bus branch or one gateway fails, then communication takes place via the second gateway and the second bus branch. A status information on the interference is transmitted via the external bus branch.

The addresses and parameters for a new gateway are set by means of a PC and the **PACT<sub>ware</sub>**<sup>TM</sup> edition 2 human machine interface.

## 7.2 Gateways for PROFIBUS DP

### 7.2.1 Gateways KSD2-GW-PRO and KSD2-GW-PRO.485

Gateways of type KSD2-GW-PRO and KSD2-GW-PRO.485 support the cyclic PROFIBUS DP data protocol in accordance with EN 50170/8-2. The KSD2-GW-PRO gateway has an RS232 service interface both in the form of a jack on the front and on screw terminals. The KSD2-GW-PRO.485 gateway has an RS 485 service interface, which is merely connected to the screw terminals. The controls consist of an LC-display with 3 1/2 digits and the three buttons "Mode", "Up" and "Down".

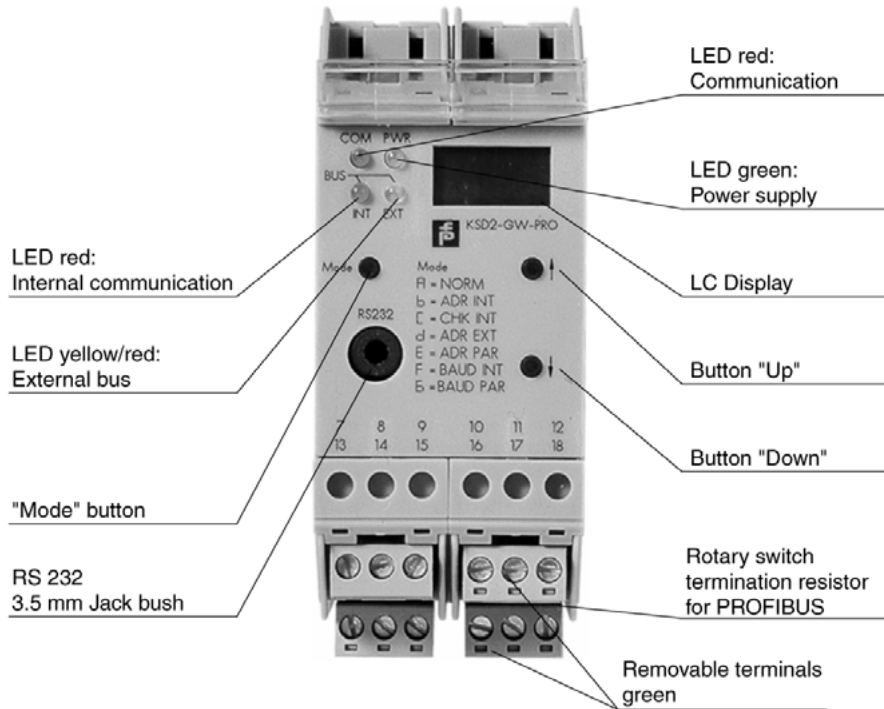

Figure 7.3:KSD2-GW-PRO gateway

### 7.2.2 Gateway KSD-GW2-PRO

The KSD2-GW2-PRO gateway supports the cyclic and acyclic PROFIBUS DP V1 data protocol and has both serial service interfaces RS232 and RS485. The controls consist of a two-lined alphanumeric LC-display with 4 digits and the four buttons "OK", "ESC", "Up" and "Down".

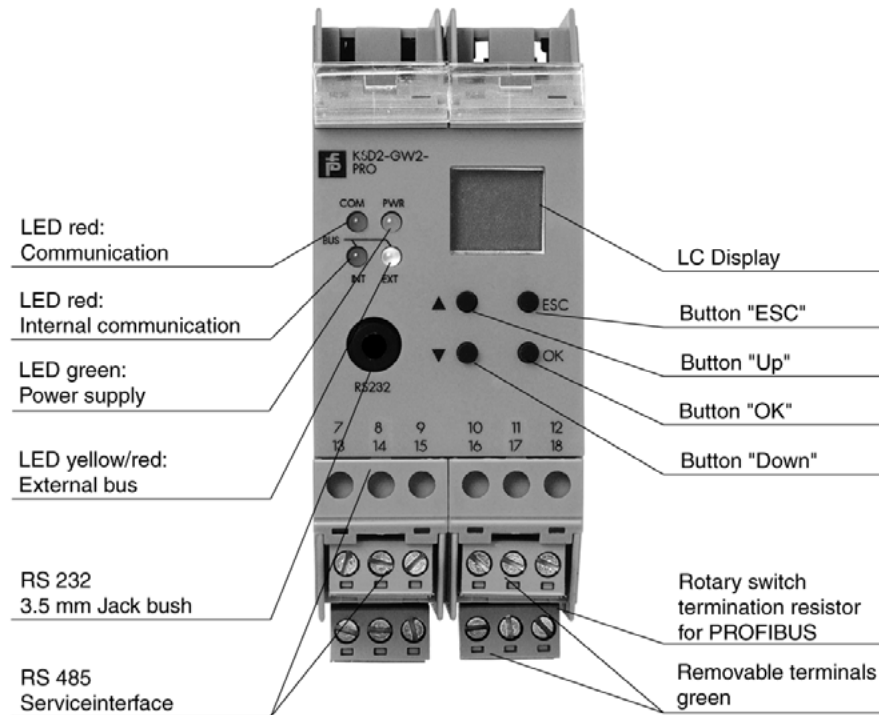

Figure 7.4:KSD2-GW2-PRO gateway

### 7.2.3 General Notes on PROFIBUS DP

PROFIBUS DP (distributed peripherals) is a standardised field bus that allows the rapid exchange of data between central automation devices and distributed field devices such as sensors and actuators. Meanwhile, the cyclic data exchange to DIN 50170 has been supplemented by PROFIBUS DP V1, which is also referred to as acyclic data traffic.



Note

Further information can be found in the PROFIBUS standard, EN 50170 (DIN 19245) and the relevant literature.

The PROFIBUS user association, PROFIBUS Nutzerorganisation e.V. (PNO), Karlsruhe, publishes information brochures and a PROFIBUS product catalogue:

PROFIBUS Nutzerorganisation e.V.  
 Haid-und-Neu-Str. 7  
 D-76131 Karlsruhe  
 Tel.: 0721 9658-590

<http://www.profibus.com>

### 7.2.4 Features of the PROFIBUS Gateways

The KSD2-GW-PRO, KSD2-GW-PRO.485 and KSD2-GW2-PRO RPI gateways connect the internal RPI bus to the external PROFIBUS. The gateway thus assumes the master function for the internal bus. The gateway has the function of a modular DP slave device on the external PROFIBUS. To increase system availability, the gateway and external bus can be implemented in a redundant configuration.

### 7.2.5 Device Connection

The electrical connection of the PROFIBUS-DP gateways by means of cables, merely involves establishing the PROFIBUS connection.

#### 7.2.5.1 Gateways of Type KSD2-GW-PRO and KSD2-GW-PRO.485

The RS 232 interface is only used to configure the RPI system. To do this, the PC (with the PACTware human machine interface) is connected to the jack on the front of the gateway via the K-ADP2 adapter. If the PC is to remain permanently connected to the RPI system as a parameterization and monitoring system, it is recommended that connection is made via the RS485 service interface using the plug-in screw terminals 7, 8 and 9.



In the case of the KSD-GW-PRO.485 gateway, with RS 485 parameterization interface, only the terminal connection is available.

Note

The jack on the front of the KSD-GW-PRO gateway and the screw terminal connection for the RS232 link cannot be used simultaneously.

#### 7.2.5.2 KSD2-GW2-PRO Gateway

The KSD2-GW2-PRO gateway is provided with both service interfaces. The RS 232 service interface is connected to the jack on the front while the RS 485 service interface is connected to the terminals.



Both service interfaces must not communicate with the gateway simultaneously.

Note

#### 7.2.5.3 Wiring

The connection to the 24 V DC power supply and to the internal bus are made via the Power Rail.

The cable connections are made via self-opening screw terminals; max. core cross-section 1 x 2.5 mm<sup>2</sup> for rigid cable or 2 x 1,5 mm<sup>2</sup> for flexible cable with plastic wire end ferrule. The screw terminal blocks can be pulled out of the device for easier connection.

Fit the gateway to the Power Rail and connect the PROFIBUS cable and, if necessary, the RS 232/RS 485 cable, as shown in the connection diagram and the terminal assignment list.

The current connection plan of the gateways is given in the "Modular Interface Housings" catalogue.

### 7.2.6 PROFIBUS Transmission Rate

The PROFIBUS gateway synchronises itself with the transmission rate of the PROFIBUS master

The following transmission rates are supported:

- 9.6 kbit/s
- 19.2 kbit/s
- 93.75 kbit/s
- 187.5 kbit/s
- 500 kbit/s
- 1.500 kbit/s



Note

The transmission rate depends on the length and type of the cable used. Detailed information can be obtained from the PROFIBUS specification EM 50170/2.

### Bus termination

With PROFIBUS, each bus segment must be terminated at both ends with terminating resistors.

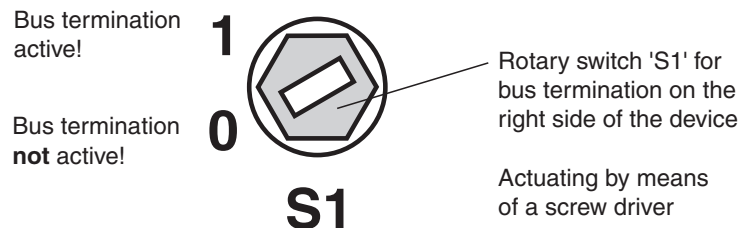

Figure 7.5: Rotary switch S1 for bus termination

The PROFIBUS gateways incorporate a switchable internal bus termination. Using a screwdriver, the bus termination can be activated on the rotary switch S1 on the right side of the housing (as viewed from the front). This is used if the gateway is installed at the end of a line.

### 7.2.7 Screening and EMC

The screening of cables provides protection against electromagnetic interference and increases electromagnetic compatibility.



Note

Information on the construction of a screen is given in the PROFIBUS directive 'PROFIBUS-DP/FMS' - available from PNO (order No. 2111).

The gateway are provided with two ground terminals (15, 16). These terminals have to be connected to ground at the place of installation.



Note

If cables with a double screen are used, e.g. wire braiding and metallised foil, both screens must be connected together at the cable ends with a low-resistance connection when making up the cable.

Power supply cables are a source of much interference radiation, e.g. the switching current of a three-phase motor. For this reason, the laying of supply cables and signal/data cables in parallel runs should be avoided, especially within the same ducting.

### 7.2.8 GSD Files

Pepperl+Fuchs provides 2 different GSD files for the configuration of an RPI/Profibus gateway:

- the PF0818.GSD file
- the PF0818P.GSD file

If the **PF0818.GSD** file is used

- a parameterization of the RPI devices by means of PACTware is obligatory
- up to 8 RPI devices can be allocated to 1 PROFIBUS DP data module (pack). This is obligatory, if there are more than 64 RPI devices on a gateway.
- In case a gateway has to be replaced, the new gateway should be parameterized via the service interface (no parameterization via PROFIBUS)

If the **PF0818P.GSD** file is used

- parameter assignment of the RPI devices is carried out via PROFIBUS. However, not all the functions of the RPI devices can be accessed. For example, scaling will no longer be possible for analogue inputs or outputs!
- Likewise, packing modules will no longer be possible (**exception**: up to 4 temperature converters can be packed).

### Defined Modules and Data Types

Many different types of module are defined in the GSD files to allow all RPI devices to be clearly represented as DP slave modules.

The modules defined are oriented to the function of the RPI modules and differ according to

Type of data:	input data (I) output data (O)
Data format:	binary (D) analogue, format: signed integer (A_INT) analogue, format: FLOAT (floating point, A_FLOAT)
Status information:	with status information (_S, _STAT) without status information
Number of channels	1 ... 8
Number of RPI modules:	1 ... 8 (nx) - Note: packing the modules

### Examples:

Type of module	Explanation
4DI_STAT	1 RPI device with 4 channels, binary input data, with status information
1AO_FLOAT	1 RPI device with 1 channel, analogue output data, floating point data format without status information
4x2DO_S KSD2-BO-Ex2	4 RPI devices, each with 2 channels are packed, binary output data, with status information, RPI device type KSD2-BO-Ex2

In addition to the modules shown above, other modules that perform special functions are defined.

These are:

### Empty modules



Note

Empty modules allow place holders to be included in the DP master configuration for modules that are not yet installed. The use of these empty modules in the configuration avoids the need to change addresses later, which can lead to problems, especially in the application program, if the RPI system has to be upgraded or expanded.

The defined empty modules are given in the device master file (GSD file).

**Example:**

Module type	Explanation
0x1AO_INT_S KSD2-CO-Ex	0 (empty module) RPI devices with 1 channel, analogue output data, 'signed integer' data format with status information, RPI device type KSD2-CO-Ex

**7.2.9 Configuration of the Cyclic Communication**

Prior to configuration, the GSD file selected for the RPI system should be copied into the prescribed directory of the configuration tool.

Having started the program, the master for the PROFIBUS communication in a new project has to be selected and the hardware is to be configured. By inserting the CPU or the communication module, the properties of the PROFIBUS stations, such as PROFIBUS address, baudrate and the profile can be set.

**7.2.9.1 Representation of the Gateway in the DP Master System**

On opening the GSD file, the RPI structure tree is reproduced in the configuration tool in order to establish the communication. This is done, by selecting the gateway from the GSD-file list and adding it to the master system. By adding the gateway as a DP slave, the PROFIBUS address is automatically assigned. The latter must correspond either to the external address in Mode 'd' or to the one in the 'Address Assign' service menu on the gateway. The PROFIBUS address, can be changed and adapted to the gateway address.

When a second gateway is used (redundant gateway), the RPI structure tree of the priority gateway is copied and pasted to the redundant one. The addresses of the two gateways must differ (this does not apply to redundant gateways operated at high-availability control systems).

The settings for the four user parameters of the DP slave must be selected according to the details listed below.

- Acyclic access via the cyclic data channel (module 0 access). This functionality is not specified in this handbook.
- Signed Integer or FLOAT format for analogue values
- Operation with or without redundant gateway
- With or without status transmission



Please note that the settings that are made via the user parameters will apply to all RPI devices of the gateway!

Note

User parameter byte	Value	Meaning
1	00h	no module 0 access (standard setting)
	01h	module 0 access activated
2	00h	signed integer format for analogue values
	01h	floating point format for analogue values
3	00h	no redundant gateway available (standard setting)
	01h	automatic switch-over to redundant gateway, in the event of the active gateway becoming defective (recommended for gateway with RPI internal address 2)
	02h	redundant gateway waiting for switch-over command
	03h	Switch-over of the passive gateway into the active mode (recommended for gateway with RPI internal address 2)
4	x0h	without status transmission
	x1h	with status transmission
	0xh	packing only possible using special IDs
	1xh	packing always possible

The setting of the data format for analogue values (user parameter byte 2) and the transmission of status values via the data telegram both have an effect on the data volume to be transmitted and thus on the memory space requirement and the cycle time.



Note

Independent of whether data transfer is carried out with or without status, the PROFIBUS diagnosis can be evaluated at any time!

More detailed information is given in section 7.2.9.3.

## 7.2.9.1 Representation of the RPI modules in the Gateway

The term "module" in the following description means the software module that communicates with PROFIBUS DP.



Attention

When selecting the RPI devices the following PROFIBUS-specific details should be considered: Use the status transmission for **all** or **none** of the devices, depending on the parameterization of the gateway.

Always use either **INT** or **FLOAT** as a data format for analogue values.

If you wish to deactivate status signals such as lead breakage for individual devices, you can do so by setting the device data in the parameterization software accordingly.

The assignment of the RPI devices to the individual DP slave module addresses is carried out automatically by the gateway, but can also be changed by a class 2 DP master device using the Set\_Slave\_Add function. A new DP slave module is always installed in the plug-in station with the lowest free DP slave module address. If no more than 64 RPI devices are connected to the gateway, each device is assigned its own DP slave module address.

RPI Bus Address	RPI Device	DP Slave Module Address
10	KSD2-BI-Ex4	0
11	KSD2-BO-Ex2.2	1
12	KSD2-TI-Ex	2
20	KSD2-CO-Ex	3
21	KSD2-BI-Ex2	4
40	KSD2-CI-S-Ex.H	5

A terminal strip for marshalling signals must be provided for conventional MSR systems (see Chapter 6 'Commissioning'). This can be done on the software side, by assigning the RPI module a different RPI bus address.

This assignment is no longer possible if there are more than 64 RPI devices on the gateway. In this case, up to eight identical RPI devices are assigned to a DP slave module (by means of the PF0818-GSD GSD file), and these are addressed by the DP master device using a common address.



Note

To allow the gateway's automatic DP slave module address assignment function to continue to operate in this case, the devices included in a DP slave module must have consecutive RPI addresses.

The sum of all the identifiers in a configuration must not exceed 244 bytes. This is a PROFIBUS constraint.



Note

If the limit of 244 bytes for the sum of all identifiers in a configuration is approached, module types that will support a number of RPI devices per module should be used as much as possible.

RPI Bus Address	RPI Device	DP Slave Module Address
10	KSD2-BI-Ex4	0
11	KSD2-BI-Ex4	
12	KSD2-TI-Ex	1
...	...	...
79	KSD2-BO-Ex4	41
80	KSD2-CO-Ex	42
81	KSD2-CO-Ex	
90	KSD2-CI-S-Ex	43

When configuring a PROFIBUS DP system, each module must be assigned a module type. The available module types are defined in the device master data file.

### 7.2.9.2 Data Structure on the PROFIBUS

Each device inserted into the DP slave window is automatically assigned an address range. The assignment of peripheral addresses to the RPI devices or to the individual DP slave modules is carried out automatically via the PLC or the host computer. However, it is also possible to assign the addresses manually to a specified input and/or output address range.

The data without status information from binary devices occupies one bit per channel. The switching state of the lowest channel number is located in the lowest bit. The efficiency of a data transmission can be increased either by packing a number of RPI modules into one DP slave module or by using multi-channel RPI modules, since, otherwise, only one bit would be occupied whereas one byte is required for the transmission.

The data transmission with status information occupies one byte per channel. The switching state of the channel is located in the lowest bit and the remaining bits transfer the status, see **Chapter 7.1. 'Status Description'**.

The data of the analogue devices is transmitted in decimal format (DEC). Temperature values are transmitted in the signed integer format at a factor of 10, whereas current values are transmitted at a factor of 100. Data transmission requires 2 byte in the signed integer format and 4 bytes in the FLOAT format. For a status information an additional byte is required, which is placed in front of the data bytes, adding up to 3 or 5 bytes per transmission.

RPI Address	RPI Modules Type	DP Module Description	DP Module Address	Input Address Length	Output Address Length
10	KSD2-BI-Ex4	4 DI	0	1 byte	---
11	KSD2-BO-Ex2	2 DO	1	---	1 byte
12	KSD2-TI-Ex	1 AI_INT	2	2 byte	---
20	KSD2-CO-Ex	1 AO_INT	3	---	2 byte
21	KSD2-BI-Ex2	2 DI	4	2 byte	---
32	KSD2-CO-Ex	1 AO_FLOAT_S	5	1	4 bytes
36	KSD2-CI-S-Ex	1 AI_FLOAT_S	6	5 bytes	---
40	KSD2-CI-S-Ex	1 AI_INT	7	2 byte	---



Note

It is not possible to combine 'INT' and 'FLOAT' or 'with status' and 'without status' in a transmission. This is a PROFIBUS constraint.



Note

Further restrictions are: a maximum of 64 DP slave modules per RPI system and a maximum of 244 bytes for the identifier of I/O data. This corresponds to the sum of all bytes in the 'input/output address' column.

The data of a maximum of 48 analogue modules with status and 'Floating Point' format can be transmitted using 244 bytes.

### 7.2.9.3 Format of the Input and Output Data

As described in the previous section, the module identifier specifies the data type and format and whether status information is to be transmitted. The format of the input and output data for the individual module types is described in this section.



Note

It should be noted that input and output data each have their own data area. This means that, for output modules, where status information is to be transmitted in addition to the user data, the status information is in the input data area and is not transmitted with the user data as is the case with the input data.

On a number of RPI modules (1...8) per module, the data is arranged module by module in ascending order according to the RPI bus address.

If a module has several channels, the data is arranged in ascending order by channel.

The arrangement of binary data within a byte is in ascending order from bit 0.

#### Data types

The following data types are used to represent input and output data:

- boolean      bit by bit data organisation
- signed integer    2 byte integer format with sign
- FLOAT      4 byte floating-point to IEEE 754 standard, short real number

#### Data structure

The structure of the data bytes transmitted is given below.

The following abbreviations are used:

CH = channel = channel number of an RPI device

D = device = number of the RPI device within a module

n = 1...8

#### Binary input and output data without status

1-channel modules:      Module types: n x 1DI, n x 1DO

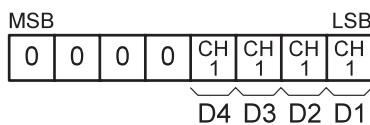

2-channel modules:      Module types: n x 2DI, n x 2DO

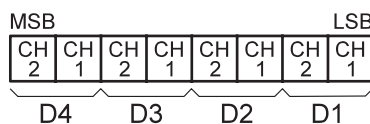

4-channel modules:      Module types: n x 4DI

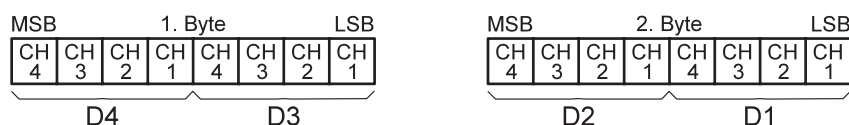

**Binary input data with status**

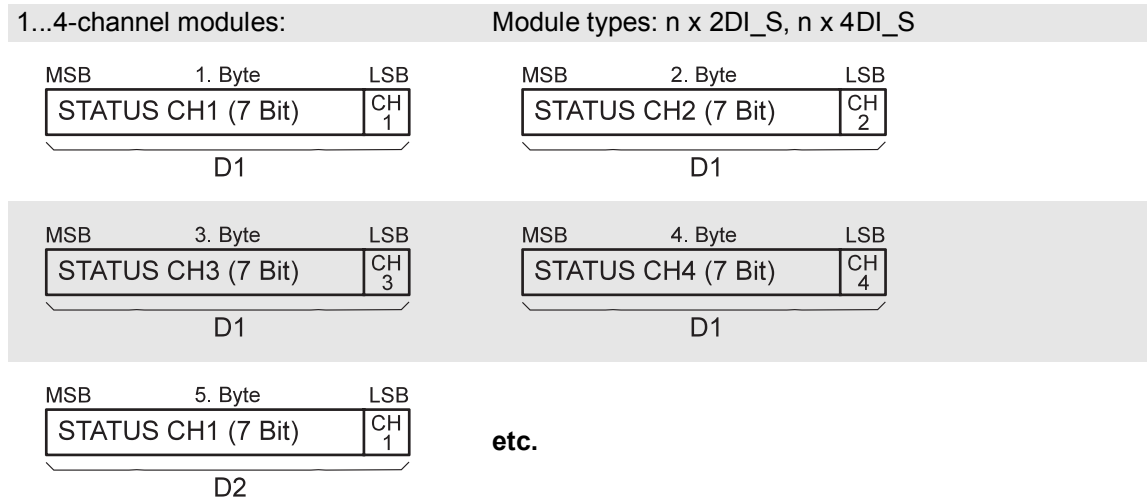

**Binary output data with status**

In the case of output data with status information, the DP master sends the output data to the DP slave and receives the status data as input data in a reply telegram, i.e. the output data is in the output data area and the status data is in the input data area of the module.

**Output data area**

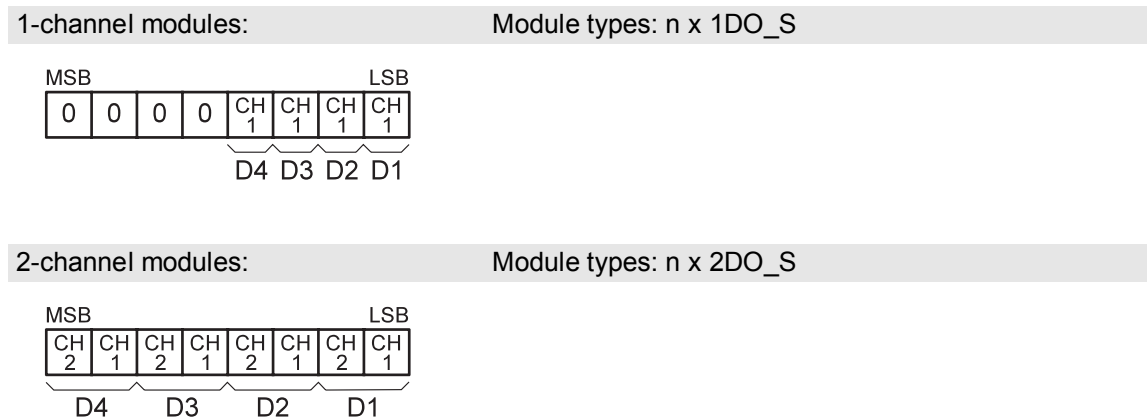

**Input data area**

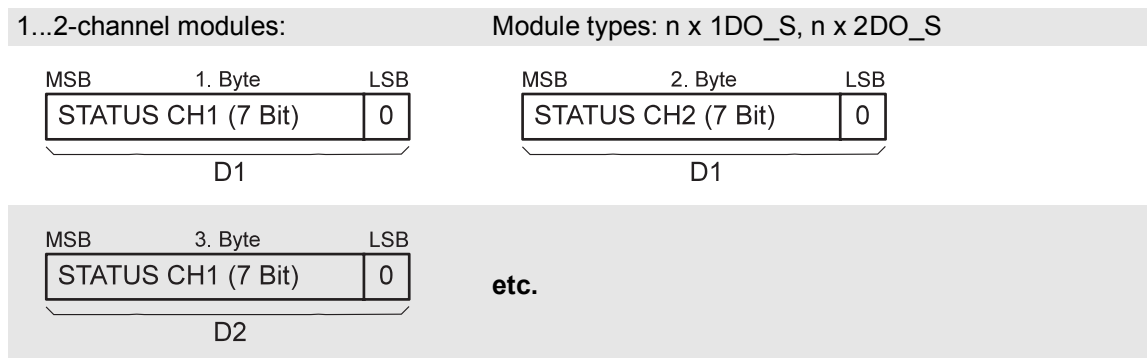

Date of issue 05/27/03

## Analogue input and output data without status

Data type: signed integer

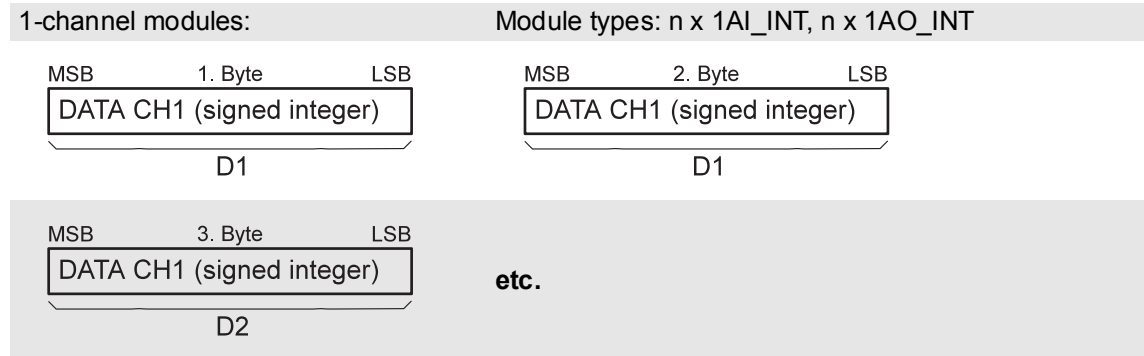

Data type: FLOAT

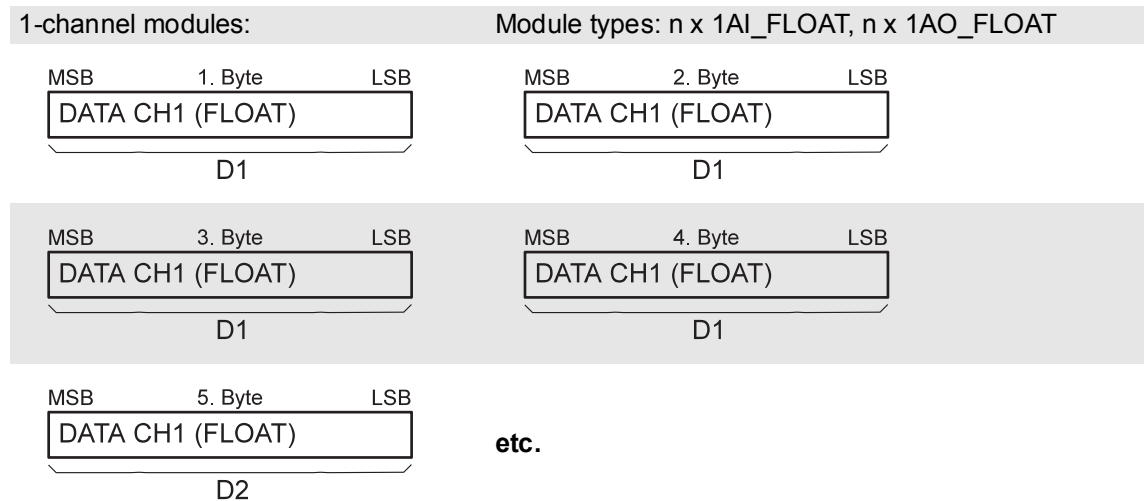

## Analogue input data with status

Data type: signed integer

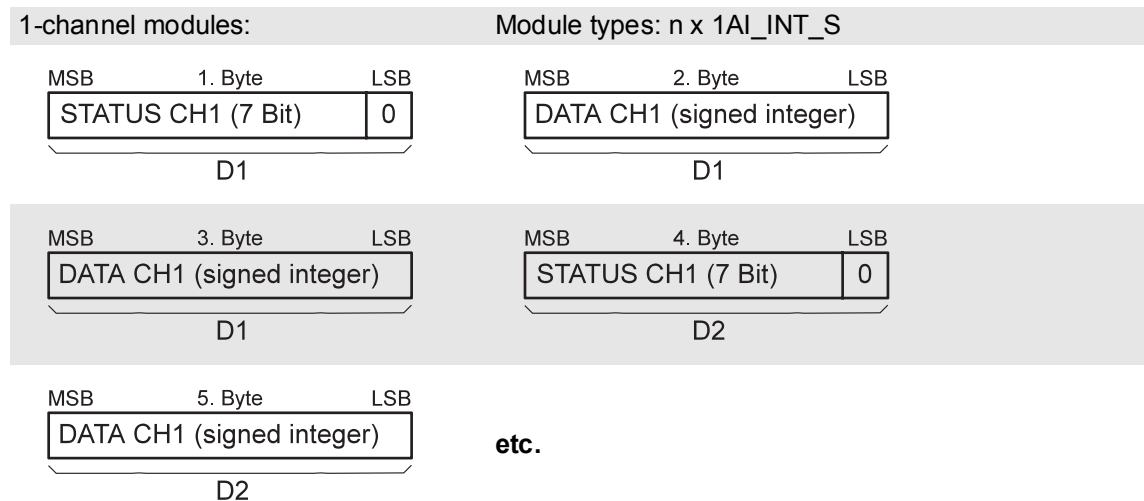

Data type: FLOAT

**1-channel modules:** **Module types: n x 1AI\_FLOAT\_S**

The position of status bytes and data bytes is the same as that of the signed integer data type, there being 4 bytes per channel for the date.

**Analogue output data with status**

In the case of output data with status information, the DP master sends the output data to the DP slave and receives the status data as input data in the reply telegram, i.e. the output data is in the output data area of the module and the status data is in the input area.

Data type: signed integer

**1-channel modules:** **Module types: n x 1AO\_INT\_S**

**Output data area**

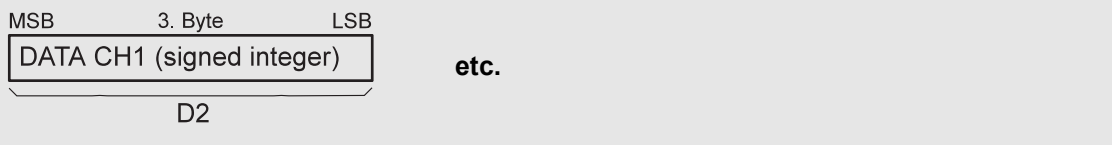
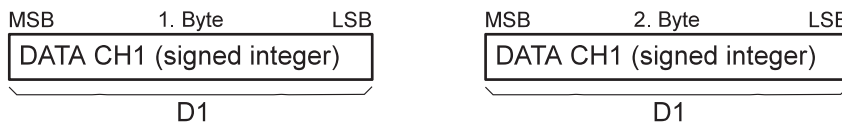

**Input data area**

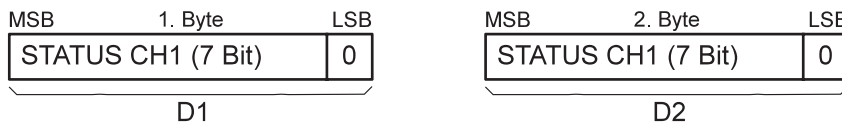

Data type: FLOAT

**1-channel modules:** **Module types: n x 1AO\_FLOAT\_S**

The configuration of the status bytes and data bytes is the same as that of the signed integer data type, there being 5 bytes of data per channel for the date.

**7.2.9.4 Structure of the Status Information**

By means of the user parameter byte 11 the RPI system can be set to allow status information for each channel to be transmitted in the data telegram. Whether this option is selected or not, diagnostic information is transmitted via the PROFIBUS DP diagnosis (see section 7.2.11)

If the "transfer with status byte" option is selected, the status byte is structured as follows:

Meaning	GW2	GW1	CD3	CD2	CD1	Q2	Q1	Dat
Good							0	0
Not certain						0	1	0
Bad			0	0	0	1	0	0
Good, no error			0	0	0	0	0	0
Measurement range exceeded/fallen short			0	1	1	0	1	X
Simulated measured value			1	0	1	0	1	X
Reserved			1	1	0	0	1	X
Configuration error			0	0	1	1	0	X
RPI device error			0	1	0	1	0	X
Field device error			1	0	0	1	0	X
No communication (last good value)			1	0	1	1	0	X
No limit value reached	0	0						X
Lower limit violated	0	1						X
Upper limit violated	1	0						X

For binary inputs and outputs the "Dat" bit 0 represents the current status of the channel. For analogue inputs and outputs it is always set to 0.

Q1 and Q2 provide information on the signal quality. If an error occurs, this bit is always logical "1".

CD1 to CD3 code any errors which have occurred. In the event of a field device error, no distinction is made between lead breakage, lead short-circuit or a defective field device.

Bits GW1 and GW2 are reserved for monitoring the limit values of analogue inputs and outputs. They are insignificant for binary signals.

### 7.2.10 Commissioning

Before commissioning, an additional check should be made that all connections are correct..

Personnel undertaking commissioning should be familiar with communication between the PROFIBUS master and the gateway. Commissioning requires knowledge of PROFIBUS-DP and how to configure and parameterize the master device.

#### Time response

The Remote Process Interface is deterministic. The RPI devices are interrogated cyclically.

The most important factors affecting the time response are::

- The higher-level host system, e.g. process control system, PLC or PC
- Type and number of PROFIBUS masters, e.g. specified transmission rate
- Type and number of PROFIBUS slaves, e.g. when using several gateways
- Communication between PROFIBUS master and host system
- Number of RPI devices and cycle time of RPI system, see Chapter 4 'Planning - Basics and Procedure'
- The user program



Note

Further information about commissioning is provided in Part 'System Description, Planning, Installation, Commissioning and Servicing'. Important information about commissioning will also be found in the technical documentation for the DP master system.

There is a whole range of project tools available that enable the PROFIBUS user to plan and commission a network without in-depth knowledge of the basic communication processes.

PC programs and PROFIBUS PC plug-in cards are available to enable the communication relationships and their parameters to be specified and to allow bus telegrams to be displayed on the screen in an understandable manner.

The system software provided with PLCs and process control systems that use PROFIBUS communications processors often provides appropriate network configuration and management facilities.

#### The most important features of the gateway with respect to PROFIBUS DP are:

- Modular DP slave, i.e. the gateway represents the RPI devices on PROFIBUS according to the RPI internal hardware structure (< 64 RPI devices; for more than 64 RPI devices several identical devices will be represented in one module).
- Full DP slave functionality with the functions: Data\_Exchange, RD\_Inp, RD\_Outp, Slave\_Diag, Set\_Prm, Chk\_Cfg, Get\_Cfg, Global\_Control, Set\_Slave\_Add
- Self-synchronising transmission rates between 9.6 and 1500 kbit/s
- Switchable bus termination
- PROFIBUS device addresses 1 ... 125 are available.

**7.2.11 Gateway-Specific Diagnostic Information**

During data transmission diagnostic data for a station, module and channel-based diagnosis can be transmitted in addition to the status information. These diagnosis messages allow a rapid error localization.

The diagnostic information consists of a standard diagnostic information (byte 1 to byte 6) and an extended DP slave specific diagnostic information.

The start of the gateway-specific diagnostic data is identified by a header byte.

Byte 7: Gateway Diagnostic Header

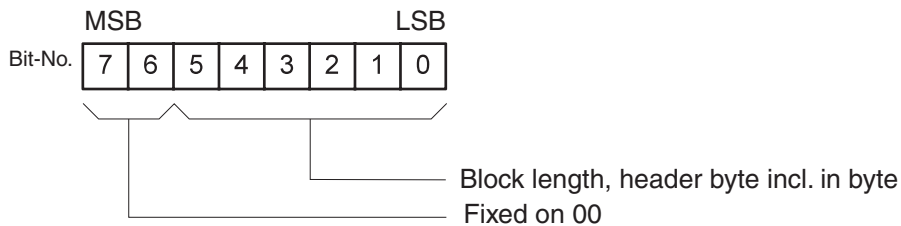

Byte 8: Gateway Status

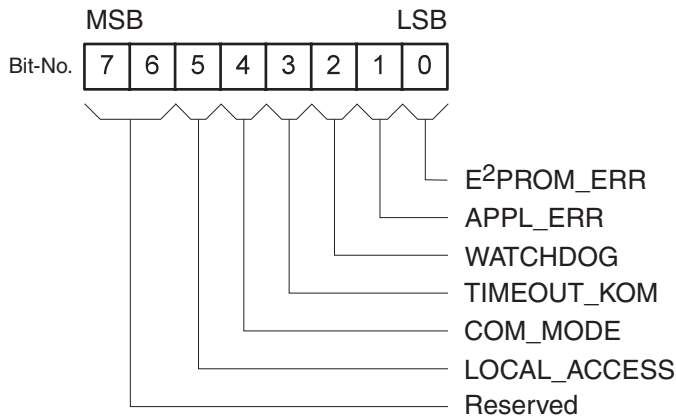

E2PROM_ERR	1 = error in E2PROM 0 = no error
APPL_ERR	1 = internal interface error 0 = no error
WATCHDOG	1 = one or more RPI modules have gone into the safe condition following expiry of the watchdog timer 0 = no error
TIMEOUT_KOM	1 = one or more RPI modules with output channels were not addressed by the gateway within the agreed time-out period or, one or more RPI modules with input channels have not sent their data to the gateway within the agreed time-out period.  0 = no error
COM_MODE	1 = one or more RPI modules have changed over from difference mode to common mode operation for communication oth the RPI internal CAN bus. 0 = no error
LOCAL_ACCESS	1 = local access has taken place on one or more RPI modules via a separate interface, e.g. via a hand-held terminal. (HART protocol transmitted)

Byte 9: RPI System Status

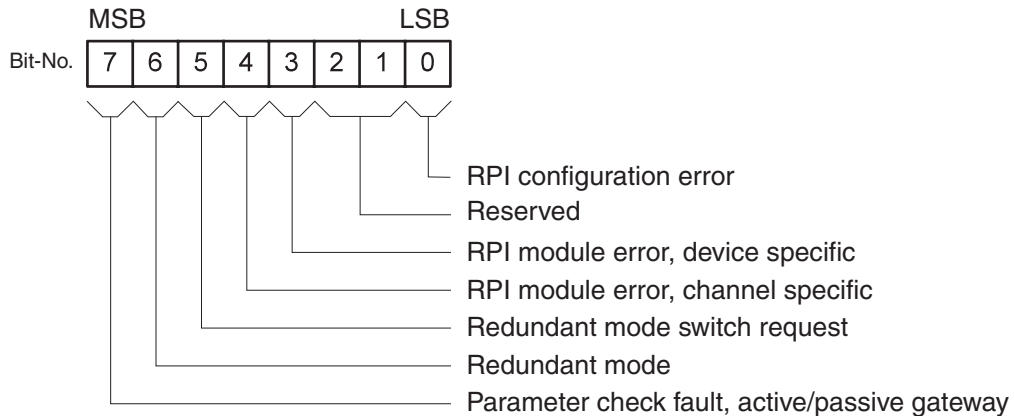

RPI configuration error	1 = the number of RPI modules on the internal bus does not correspond with the gateway configuration. 0 = no error
RPI module error, device specific	1 = device-specific error in one or more RPI modules 0 = no error
RPI module error, channel specific	1 = channel-specific error in one or more RPI modules 0 = no error
Redundant mode switch request	1 = in redundant mode with two gateways the gateway expected a mode switch-over command. 0 = no request received
Redundant mode	1 = RPI in redundant mode 0 = RPI not in redundant mode
Parameter check error,	1 = error when comparing parameter sets of active and passive gateways 0 = no error

Byte 10: DP Configuration Status

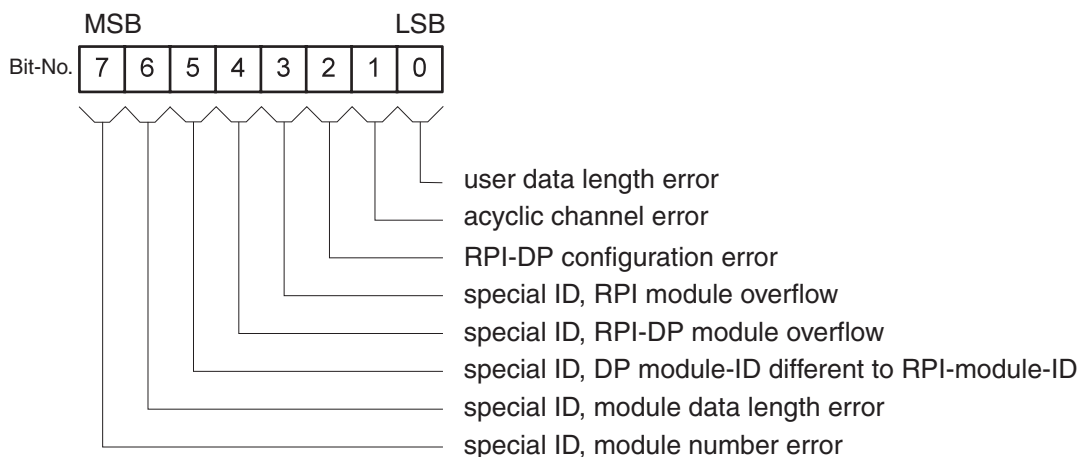

Date of issue 05/27/03

User data length error	1 = max. process data length of 244 bytes exceeded 0 = no error
Acyclic channel error	1 = acyclic transmission error, module 0 access 0 = no error
RPI-DP configuration error	1 = the RPI configuration does not correspond with the configuration of the DP master 0 = no error
Special ID, RPI module overflow	1 = more than 64 RPI devices have been configured 0 = no error
Special ID, RPI-DP module overflow	1 = more RPI devices have been configured than there are DP modules available 0 = no error
Special ID, DP module ID different to RPI module ID	1 = the device ID in the identifier of a DP slave module does not correspond with the device ID of the assigned RPI device. 0 = no error
Special ID, module data length error	1 = the defined user data length of the RPI and DP configurations do not correspond 0 = no error
Special ID, module number error	1 = the number of RPI devices to be packed does not correspond with the special identifier 0 = no error

### Byte 11: Status counter

The value of the status counter is stored in this byte. The status counter is an 8 bit counter that is incremented every time a change is made to the status information.

### Byte 12: Param counter

The value of the parameter counter is stored in this byte. The parameter counter is an 8 bit counter that is incremented every time a change is made to the parameter assignment, whether via the gateway or via an RPI module.



When module 0 access is activated (see Chapter 7.2.2), additional information is inserted after byte 12 'Param Counter'..

**Note**

Module 0 access has no significance for normal operation. More information about module 0 access is available on request.

### Module-specific diagnostic information

The start of the module-specific diagnosis data is identified by a header byte..

#### Header byte.: Module diagnostics header

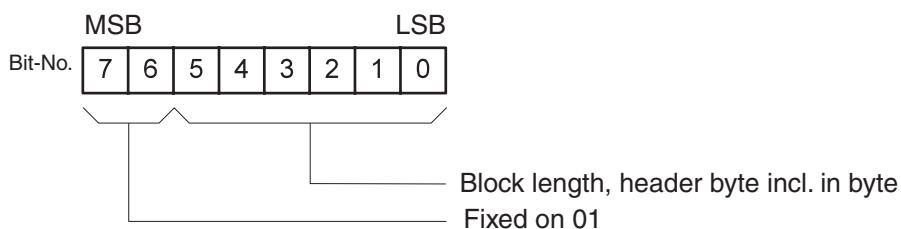

Module-specific diagnosis information with the block lengths specified in the header byte follow the header byte. Each bit in these diagnosis bytes represents a DP module. If a bit is set, diagnostic information is available for that module.

**Structure of diagnostic byte**

**1st module diagnostic byte**

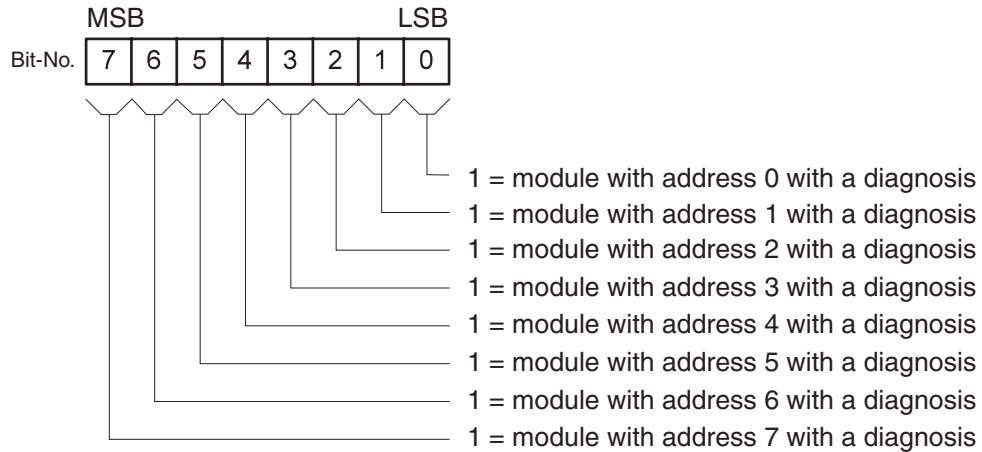

The following 7 module diagnostic bytes contain the appropriate information for all further modules defined in the configuration (max. 64)..

**Channel-specific diagnostic information**

The channel-specific diagnostic data follows the module-specific diagnostic data, in order, for all modules that have been diagnosed. The length of each diagnostic entry is 3 bytes.

Byte 1: Module number

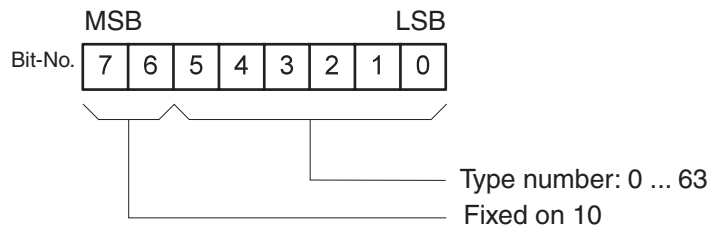

Byte 2: Channel number

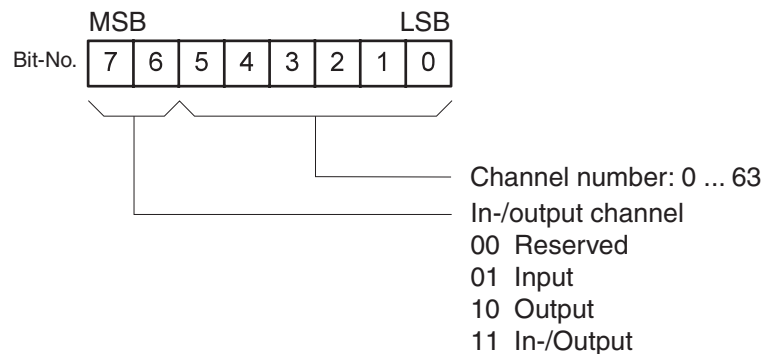

Byte 3: Type of diagnosis

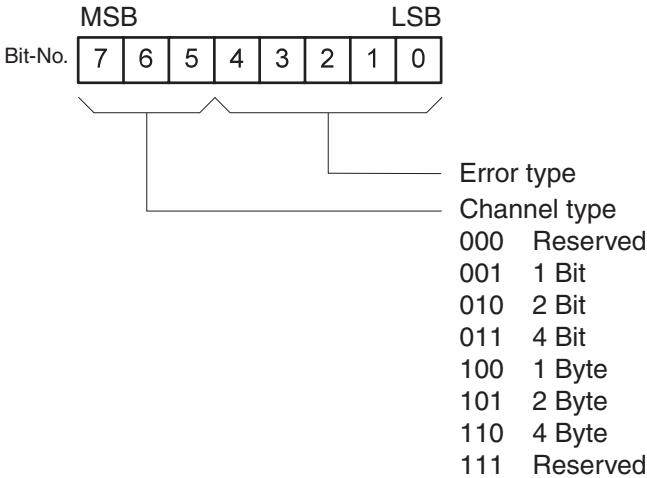

**Type of error:**

0 <sub>dec</sub>	0 <sub>hex</sub>	reserved
1 <sub>dec</sub>	1 <sub>hex</sub>	lead short-circuit
2 <sub>dec</sub>	2 <sub>hex</sub>	under-voltage
3 <sub>dec</sub>	3 <sub>hex</sub>	over-voltage
4 <sub>dec</sub>	4 <sub>hex</sub>	overload
5 <sub>dec</sub>	5 <sub>hex</sub>	over-temperature
6 <sub>dec</sub>	6 <sub>hex</sub>	lead breakage
7 <sub>dec</sub>	7 <sub>hex</sub>	upper limit violated
8 <sub>dec</sub>	8 <sub>hex</sub>	lower limit violated
9 <sub>dec</sub>	9 <sub>hex</sub>	error
10 <sub>dec</sub>	A <sub>hex</sub>	reserved
:	:	:
15 <sub>dec</sub>	F <sub>hex</sub>	reserved
16 <sub>dec</sub>	10 <sub>hex</sub>	upper alarm limit violated
17 <sub>dec</sub>	11 <sub>hex</sub>	lower alarm limit violated
18 <sub>dec</sub>	12 <sub>hex</sub>	top of range violated
19 <sub>dec</sub>	13 <sub>hex</sub>	bottom of range violated
20 <sub>dec</sub>	14 <sub>hex</sub>	not used
:	:	:
31 <sub>dec</sub>	1F <sub>hex</sub>	not used

**Note**

The diagnosis diagram contains a maximum of 64 bytes, i.e. if more than 13 DP modules develop a fault, the gateway cuts off the information after 64 bytes.

## Summary of the structure of the standard diagnosis for the RPI system

Structure of the PROFIBUS DP User Diagnosis for the RPI System	
Prerequisite: No module 0 access	
PROFIBUS DP Diagnosis Byte	Meaning
<b>Gateway Diagnosis</b>	
7	always 6hex; block length gateway diagnosis including header byte.
8	gateway status
9	RPI system status
10	PROFIBUS DP configuration status
11	counter status
12	paramter counter
<b>PROFIBUS DP Module Diagnosis</b>	
13	always 49 hex; block length module diagnosis (9 bytes) including header byte.
14	PROFIBUS DP module 0 to 7 (LSB = module 0; MSB = module 7)
15	PROFIBUS DP module 8 to 15 (LSB = module 8; MSB = module 15)
16	PROFIBUS DP module 16 to 23 (LSB = module 16; MSB = module 23)
17	PROFIBUS DP module 24 to 31 (LSB = module 24; MSB = module 31)
18	PROFIBUS DP module 32 to 39 (LSB = module 32; MSB = module 39)
19	PROFIBUS DP module 40 to 47 (LSB = module 40; MSB = module 47)
20	PROFIBUS DP module 48 to 55 (LSB = module 48; MSB = module 55)
21	PROFIBUS DP module 56 to 63 (LSB = module 56; MSB = module 63)
<b>Channel Diagnosis</b>	
22	module number (bit 7 = 1, bit 6 = 0)
23	bit 0 to 5 channel number; bit 6, 7 input and/or output channel
24	type of channel; type of error
...	....
64	max. 13 faulty modules



Note

It should be noted that an indication of the faulty PROFIBUS DP data module is not synonymous with the RPI internal address of the faulty RPI module. This applies especially to the case where packed modules are used.

The channel diagnosis is only transmitted when a channel error occurs.

### 7.3 KSD2-GW-MOD and KSD2-GW-MOD.485, Gateways for the Modbus RTU

Gateways KSD2-GW-MOD and KSD2-GW-MOD.485 support the command and reply telegram, according to MODICON Modbus protocol, Reference Guide, PI-MBUS-300 Rev.D. The gateway incorporates a serial RS 232 or RS 485 parameterization interface, optionally. The operating level consists of an 3 1/2 digit LC-display and of the three pushbuttons "Mode", "Up" and "Down".

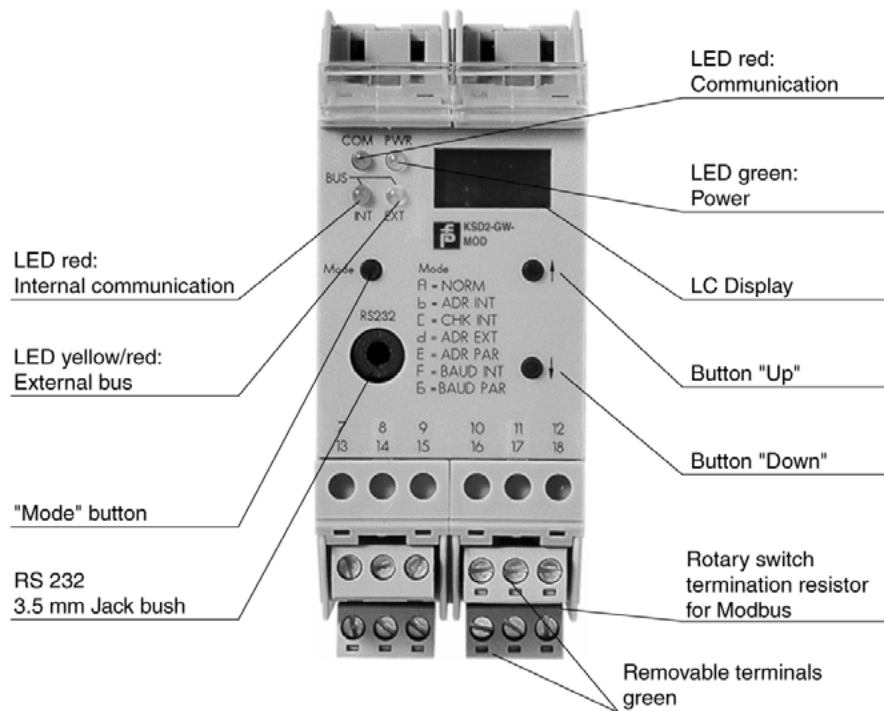

Figure 7.2: KSD2-GW-MOD gateway

#### Features of KSD2-GW(2)-MOD / KSD-GW-MOD.485 gateways

The gateways connect the RPI internal CAN bus to the external Modbus RTU. The gateway thus assumes the master function for the internal bus. The gateway has the function of a slave device on the external Modbus. To increase system availability, the gateway and external bus can be implemented in a redundant configuration.

### 7.3.1 Device Connection

The electrical connection of the KSD2-GW-MOD Modbus gateway by means of a cable, merely involves establishing the Modbus connection. The Modbus interface is an RS 485, on which up to 32 stations can be operated.

The service interface can be either an RS 232 (KSD2-GW-MOD) or an RS 485 interface (KSD2-GW-MOD.485); it is used to configure and parameterize the RPI system with the RPI human machine interface. To do this, the PC is connected to the gateway via the service interface.

If the RS 232 interface is used, connection to the PC can be made via the K-ADP2 adapter. A jack socket is provided on the front of the gateway for this purpose. If the PC is to remain connected to the RPI system as a parameterising and monitoring device, it is recommended that connection is made via the plug-in screw terminals 7, 8 and 9, which are in parallel with the jack socket.

On the KSD2-GW-MOD.485 gateway, with the RS 485 interface, only the terminal connection is available. The complete configuration of the RPI system can also be undertaken from the control system, via the Modbus, providing that the control system supports this.



Note

The jack socket on the front and the screw terminal connection for the RS 232 link cannot be used simultaneously.

Connection to the 24 V DC supply and to the internal bus is achieved via the Power Rail.

The cable connections are made via self-opening screw terminals, max. core cross-section 1 x 2.5 mm<sup>2</sup> for rigid cables or 2 x 1.5 mm<sup>2</sup> for flexible cables with plastic wire end ferrule. The screw terminal blocks on the device can be removed for ease of connection.

Mount the gateway on the Power Rail and connect the Modbus cable and, if necessary, the RS232/RS485 cable.

The connection plan for the gateway can be obtained from the current issue of the "Interface DIN-Rail Housing" catalogue.



Note

The number of stations on one RS485 interface (Modbus interface, such as the RS485 service interface) is a maximum of 31, as standard.

The maximum length of lead on a bus segment is effectively determined by the following parameters:

- Type of bus cable used
- Transmission rate
- External interference effects
- Number of bus stations

More detailed information on the determination of the maximum lead length can be obtained from EIA 485 or ISO 8482.

## Bus termination



Note

On the Modbus, each bus segment must be terminated by resistances at both ends of the line.

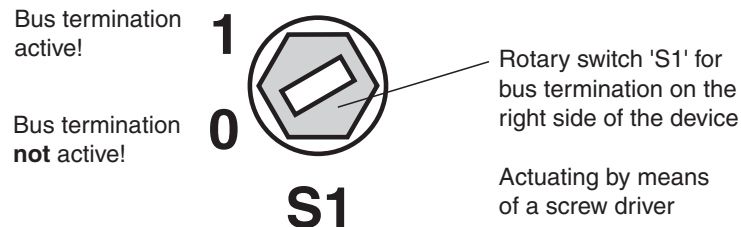

Figure 7.3: Rotary switch S1 for bus termination

The Modbus gateways operate internally via a switchable bus termination. Using a screwdriver, the bus termination can be activated on the rotary switch S1 on the right side of the housing (as viewed from the front). This is used if the gateway is installed at the end of a line.

### 7.3.2 Commissioning

Before commissioning, check once again that all the connections are correct.

Familiarise yourself with the method of communication between the Modbus master and the gateway. Commissioning requires a knowledge of the Modbus and the parameter assignment of the Modbus gateway.

### Time response

The Remote Process Interface is deterministic. The RPI devices are interrogated cyclically

The most important factors which determine the time response are:

- the higher level host system, e.g., PLC, PC or other control system
- the type and number of Modbus stations
- the set Modbus transmission rate
- the number of the RPI devices and the cycle time of the RPI system
- the user program

Further information on commissioning can be found in Section 5 of this handbook.

### 7.3.3 Operation with a Redundant Gateway

Operation with redundant gateways increases the availability of the system. The gateway that is active in normal operation must have the RPI address 1, whilst the redundant gateway must have the RPI address 2.

The prerequisite for the operation of a system with a redundant gateway, is that the configuration data for each RPI device is stored in a file in the current project directory.

The following describes the installation procedure that is necessary in the case of a gateway newly delivered from the manufacturer.

If this not the case, connect the Modbus gateway alone to a 24 V DC supply and depress the mode button on Modbus A for longer than 3 s. This causes the current configuration (here: no device) to be taught-in.

In the following it is assumed that the RPI devices are pre-configured and mounted on the Power Rail. If this is not the case, then when the active gateway has been installed (step 1) the RPI devices must be addressed. The information required for this procedure is given in Section 5 of this handbook.

The following sequence should then be carried out:

1. Mount a gateway on the Power Rail and set the RPI address of this gateway to 1 (active gateway).

2. Teach the current configuration into Modbus A.
3. Load the project into the gateway (download) using the **PACT<sub>ware</sub>**<sup>TM</sup> software.
4. Mount the 2nd gateway on the Power Rail and set the RPI address of this gateway to 2 (redundant gateway).
5. Connect the PC to the redundant gateway and then repeat steps 2 and 3 for the redundant gateway.

If the project has been downloaded into the redundant gateway, the system is ready for redundant operation.

When both gateways have been configured, the type and method of switching from the active to the redundant gateway must be established. This takes place in register table 3, register address 4360, where the following modes can be set:

Value	Description
00h	No redundancy
01h	Automatic switch-over to redundant gateway, in the event of the active gateway becoming defective
02h	Switch-over to the redundant gateway by the host (see gateway diagnosis)
03h	Switch-over of the passive gateway into the active mode

#### 7.3.4 Operation on the Modbus

The Modbus is a register-orientated bus system. This means that the data is automatically stored in a memory area, the so-called registers of the Modbus gateway. The user can access specific data by reading these registers and set targeted outputs by writing to them. These registers are organised into four tables:

Table	Contents
1	Binary outputs
2	Binary inputs
3	Analogue outputs, acyclic parameter channels
4	Analogue inputs, DEVICE_TYP and DEVICE_ID

The Modbus offers two transfer modes for data exchange: the ASCII and the RTU mode..



Note

The KSD2-GW-MOD and KSD2-GW-MOD.485 gateways only support the RTU mode.

The Modbus master informs the slave via the function code which table should be interrogated and whether values are to be read or written. The following table shows which function codes are supported by the Modbus gateway:

Code	Function	Description
01	Read Coil Status	Read binary outputs
02	Read Input Status	Read binary inputs
03	Read Holding Register	Read from write/read registers, e.g. analogue outputs, acyclic parameter channels
04	Read Input Register	Read from read registers, e.g. analogue inputs, device type, device ID
05	Force Single Coil	Write binary outputs
06	Preset Single Register	Read from write/read registers, e.g. analogue outputs, acyclic parameter channels
07	Read Exception Status	Read the exception status of the gateway
08	Read Diagnostic	Service functions for Modbus
15	Force Multiple Coils	Block-wise writing of binary outputs
16	Preset Multiple Registers	Block-wise writing of analogue outputs or acyclic parameter channels

These function codes are part of the Modbus message. The Modbus message also gives the register address of the first and the number of registers to be processed. The following relationship between the transferred register address and the register to be processed should be noted:

The register address transferred in the message is always referenced from zero. The register address 0 must be transferred in order to be able to access the first register that can be interrogated (Register number 1).

**Example:**

In order to access register 26 in table 2 (status of the binary input RPI address 3, channel 1), the function code 2 and the register address 25 must be transferred.



Note

In the following description, the register addresses to be transferred are given as a basis. If your software register numbers are to be used in processing, the "given register address + 1" value must be used.

The equations used to calculate the register addresses and a description of how the data is represented in the individual registers, are given in 7.3.6 to 7.3.13. Section 7.3.16 provides a tabular summary of all the equations.

Detailed information on the Modbus protocol can be obtained from the "Modicon modbus protocol, reference guide, PI-MBUS-300 Rev.D"

A register is 16 bits long. In this handbook the data is represented as follows:

Register higher byte								Register lower byte							
MSB				LSB				MSB				LSB			
Bit 15	Bit 14	Bit 13	Bit 12	Bit 11	Bit 10	Bit 9	Bit 8	Bit 7	Bit 6	Bit 5	Bit 4	Bit 3	Bit 2	Bit 1	Bit 0

### 7.3.5 Reading Binary Input Data without Status

The expression "binary input data" is intended to imply the switching states of switches and proximity sensors.

The KSD2-GW-MOD and KSD2-GW-MOD.485 provides the user with this data, both channel-based and device-based. In the case of the channel-based representation, each channel of a device is presented in an individual register. This type of representation is to be preferred if only one channel is to be read. In the device-based type of representation, up to four RPI devices can be represented in one register.

This type of representation enables the data of many RPI devices to be transmitted with relatively small

amounts of data. The prerequisite for this is that the RPI addresses of the devices are consecutive. Further information on the relationship between RPI address and data range can be obtained from the relevant topics within this section.

**Register addresses for channel-based registers**

**Reading a channel**

This data is deposited in register table 2, which can be called-up via the function code 02.

The register address depends on the RPI internal address of the device and on the channel. It can be derived from the following equations:

max. Channel No.	Register address
8	8*RPI address + channel number - 1
4	4*(RPI address - 3) + channel number + 1035

RPI address = 3 ... 127; channel number = 1 ... 4

The information is represented as follows:

0	0	0	0	0	0	0	0	0	0	0	0	0	0	0	0	0	Ch
---	---	---	---	---	---	---	---	---	---	---	---	---	---	---	---	---	----

**Reading a number of channels and/or status information**

This data is deposited in register table 4, which can be called-up via the function code 04.

Analogue input data is usually read from the input registers (register table 04) of a Modbus station by PLCs or process control systems. In exceptional cases, it may be that control of the access to the input register is not supported. In these cases, the correct register address can be obtained from Chapter 7.3.13.

RPI devices with a maximum of 8 channels without status, 1 device per register

All data from 1-, 2-, 4- and 8 channel devices is filed in this area.

The register address is obtained from the following equation:

**Address = RPI address + 1536**

The data is represented as follows:

0	0	0	0	0	0	0	0	0	0	Ch 8	Ch 7	Ch 6	Ch 5	Ch 4	Ch 3	Ch 2	Ch 1
---	---	---	---	---	---	---	---	---	---	------	------	------	------	------	------	------	------

Channels not available are set to 0.

**RPI devices with a maximum of 4 channels, 4 devices per register**

All data from 1-, 2- and 4 channel devices are filed in this area.

The register address is obtained from the following equation:

**Address = Int[(RPI address-3)/4] + 9216**

Int (...) signifies a whole number of (...) rounded down.

The data is represented as follows:

RPI address+3				RPI address+2				RPI address+1				RPI address			
Ch 4	Ch 3	Ch 2	Ch 1	Ch 4	Ch 3	Ch 2	Ch 1	Ch 4	Ch 3	Ch 2	Ch 1	Ch 4	Ch 3	Ch 2	Ch 1

If the term  $(\text{RPI address} - 3)/4$  is divisible without a remainder, then the data is that which is represented in the low nibble of the lower byte (RPI address, Ch 1 ... Ch 4 or bit 0 to bit 3 of the register). If the division results in a remainder, this remainder describes the nibble of the register in which the data is represented. The following relationship applies:

Remainder	Data
0	Lower byte, low nibble or bit 0 to bit 3
1 or x.25	Lower byte, high nibble or bit 4 to bit 7
2 or x.50	Higher byte, low nibble or bit 8 to bit 11
3 or x.75	Higher byte, high nibble or bit 12 to bit 15

x = arbitrary digit before decimal point

**Example 1:** To find the address for an RPI device with RPI address 27:

The division  $(\text{RPI address} - 3)/4$  gives 6, without a remainder.

Hence the register address is  $6 + 9216 = 9222$ .

The 4 channels are represented in the low nibble of the lower byte.

**Example 2:** To find the address for an RPI device with RPI address 37:

The division  $(\text{RPI address} - 3)/4$  gives 8.5, or 8 with a remainder of 2.

The address to be transferred is therefore given by  $8 + 9216 = 9224$ .

The remainder shows that channels 1 to 4 of this device are represented in the low nibble of the higher byte of this register.

Channels which are not available are set to 0.

**RPI devices with a maximum of 8 channels, 2 devices per register**

All data from 1-, 2-, 4- or 8 channel devices are filed in this area.

The register address is obtained from the following equation:

$$\text{Address} = \text{Int}[(\text{RPI address} - 2)/2] + 9345$$

Int (...) denotes a whole number of (...) rounded down

The data is represented as follows:

RPI address+1								RPI address							
Ch 8	Ch 7	Ch 6	Ch 5	Ch 4	Ch 3	Ch 2	Ch 1	Ch 8	Ch 7	Ch 6	Ch 5	Ch 4	Ch 3	Ch 2	Ch 1

It should be noted, that fundamentally, only even RPI addresses are represented in the lower byte of a register and odd RPI addresses in the higher byte.

Channels not available are set to 0.

**7.3.6 Reading binary input data with status**

This data is deposited in register table 4, which can be called-up via the function code 04.

This data is exclusively represented as device-based. The switching state (bit 0) and 7 status bits (bit 1 to 7) are available in one data byte. The exact structure is shown in the following table:

GW2	GW1	CD 3	CD 2	CD 1	Q2	Q1	Dat
-----	-----	------	------	------	----	----	-----

Bits GW1 and GW2 are of no significance for binary inputs.

CD1 to CD3 code the error that has occurred.

Q1 and Q2 provide information on signal quality.



Note

Analogue input data is usually read from the input registers of a Modbus station by PLC's or process control systems. In exceptional cases, it may be that control of access to the input register is not supported. In this case the correct register addresses can be obtained from Chapter 7.3.13.

Three error messages are generated for the binary data, the significance of which is given in the following table:

Meaning	GW2	GW1	CD3	CD2	CD1	Q2	Q1	Dat
Internal memory or interface error	0	0	0	1	0	1	0	
No communication	0	0	1	0	1	1	0	
Sensor error	0	0	1	0	0	1	0	

The first two lines indicate an error in the RPI device. The third line indicates a lead breakage or short circuit, where this information is only generated if the option(s) lead breakage monitoring or short circuit monitoring is/are activated on the device. Further details can be found in **PACT<sub>ware</sub>**<sup>TM</sup> or in Section 12 of this handbook.

**RPI devices with a maximum of 4 channels with status, 2 registers per RPI device**

The data from 1-, 2- or 4 channel devices is deposited in this area. 2 registers must be read in order to obtain the complete information for all channels.

The register address is obtained from the following equation:

$$\text{Address} = 2 * (\text{RPI address} - 3) + 3587$$

The data is represented as follows:

**Register address**

High byte = Channel 2		Low byte = Channel 1
-----------------------	--	----------------------

**Register address + 1**

High byte = Channel 4		Low byte = Channel 3
-----------------------	--	----------------------

The data for channels which are not available is set to 0.

**RPI devices with a maximum of 8 channels with status, 4 registers per RPI device**

The data from 1-, 2-, 4- or 8 channel devices are filed in this area. 4 registers must be read in order to obtain the complete information for all channels.

The register address is obtained from the following equation

$$\text{Address} = 4 * (\text{RPI address} - 3) + 3084$$

The data is represented as follows:

**Register address****Register address+1****Register address+2****Register address+3**

The data for channels which are not available is set to 0.

**7.3.7 Writing/Reading Binary Output Data without Status**

Binary output data includes signals for valves, operating coils of relays and optical and acoustic alarms.

The KSD2-GW-MOD and KSD2-GW-MOD.485 provide this data, both channel-based and device-based. In the channel-based form of representation, each channel of a device is represented in an individual register. This type of representation is to be preferred if only 1 channel is to be read or written to. In the case of the device-based form of representation, up to 4 RPI devices can be represented in one register. This form of representation enables the data of many RPI devices to be transmitted with relatively small amounts of data.



Note

The prerequisite for this is that the RPI addresses of the devices are consecutive.

Further information on the relationship between RPI address and data range can be obtained from the corresponding topics in this section.

**Register addresses for channel-based registers**

**Writing/reading a channel**

This data is deposited in register table 1. The current states can be read via function code 01 and written to with function code 05.

The register address is dependent on the RPI internal address of the device and the channel. It can be derived from the following equations:

Max. Channel No.	Register address
8	8*RPI address + channel number - 1
4	4(RPI address - 3) + channel number + 1035

The RPI address can be in the range 3 to 127.

The information is represented as follows::

0	0	0	0	0	0	0	0	0	0	0	0	0	0	0	0	Ch 1
---	---	---	---	---	---	---	---	---	---	---	---	---	---	---	---	------

**Reading a number of channels and/or status information**

This data is deposited in register table 3, which can be read via function code 03 and written to via function code 06.



Note

Analogue input data is usually read from the input registers (Table 04) of a Modbus station by PLC's or process control systems. In exceptional cases, it may be that control of access to the input register is not supported. In this case the correct register addresses can be obtained from Chapter 7.3.13.

**RPI devices with a maximum of 8 channels, 2 devices per register**

All data from 1-, 2-, 4 and 8 channel devices is filed in this area.

The register address is obtained from the following equation:

$$\text{Address} = \text{Int}[(\text{RPI address}-2)/2] + 9345$$

Int (...) denotes a whole number of (...) rounded down.

The data is represented as follows:

RPI address+1								RPI address							
Ch 8	Ch 7	Ch 6	Ch 5	Ch 4	Ch 3	Ch 2	Ch 1	Ch 8	Ch 7	Ch 6	Ch 5	Ch 4	Ch 3	Ch 2	Ch 1

It should be noted, that fundamentally, only even RPI addresses are represented in the lower byte of a register and odd RPI addresses in the higher byte.

Channels not available are set to 0.

**RPI devices with a maximum of 4 channels, 4 devices per register, without status**

All data from 1-, 2- and 4 channel devices is filed in this area.

The address is obtained from the following equation:

$$\text{Address} = \text{Int}(\text{RPI address}/4) + 9216$$

Int (...) denotes division without a remainder.

The data is represented as follows:

RPI address+3				RPI address+2				RPI address+1				RPI address			
Ch 4	Ch 3	Ch 2	Ch 1	Ch 4	Ch 3	Ch 2	Ch 1	Ch 4	Ch 3	Ch 2	Ch 1	Ch 4	Ch 3	Ch 2	Ch 1

If the term RPI address / 4 is divisible without a remainder, this implies that the data will be represented in the low nibble of the lower byte (RPI address, Ch 1 ... Ch 4 or bit 0 to bit 3 of the register). If the division results in a remainder, then this remainder describes the nibble of the register in which the data is represented. The following relationship applies:

Remainder	Data
0	Lower byte, low nibble or bit 0 to 3
1 or x.25	Lower byte, high nibble or bit 4 to bit 7
2 or x.50	Higher byte, low nibble or bit 8 to bit 11
3 or x.75	Higher byte, high nibble or bit 12 to bit 15

x = arbitrary digit before decimal point

**Example 1:** To determine the register address for an RPI device with RPI address 36.

The division RPI address/4 gives 9. The register address to be transferred is  $9 + 9216 = 9225$ . The remainder from the division indicates that channels 1 to 4 of this device are represented in the low nibble of the lower byte of this register.

**Example 2:** To determine the register address for an RPI device with RPI address 27

The division RPI address/4 gives 6.75 or 6 with a remainder of 3. Therefore the address to be transferred is 9222. The remainder from the division indicates that channels 1 to 4 of this device are represented in the high nibble of the higher byte of this register.

Channels which are not available are set to 0.

**7.3.8 Writing/Reading Binary Output Data with Status**

This data is deposited in register table 3, which can be read via function code 03 and written to via function code 06.

This data is represented exclusively device-based. The switching state (bit 0) and 7 status bits (bit 1 to 7) are included in one data byte. The exact construction is as follows:

GW2	GW1	CD 3	CD 2	CD 1	Q2	Q1	Dat
-----	-----	------	------	------	----	----	-----

The bits GW1 and GW2 are of no significance for binary output signals.  
 CD1 to CD3 code the error that has occurred.  
 Q1 and Q2 provide information on signal quality.

Analogue input data is usually read from the input registers of a Modbus station by PLC's or process control systems. In exceptional cases, it may be that control of access to the input register is not supported. In this case the correct register addresses can be obtained from Section 7.3.13.

Three error messages are generated for the binary data, the significance of which is given in the following table:

Meaning	GW2	GW1	CD3	CD2	CD1	Q2	Q1	Dat
Internal memory or interface error	0	0	0	1	0	1	0	
No communication	0	0	1	0	1	1	0	
Field device error	0	0	1	0	0	1	0	

The first two lines indicate an error in the RPI device. The third line indicates a lead breakage or short circuit, where this information is only generated if the option(s) of lead breakage monitoring or short circuit monitoring are activated on the device. Further information can be obtained from Part B of this handbook.

**RPI devices with a maximum of 4 channels with status, 2 registers per RPI device**

The data from 1-, 2- or 4 channel devices are filed in this area. 2 registers must be read in order to obtain the complete information for all channels.

The register address is obtained from the following equation:

$$\text{Address} = 2 * (\text{RPI address} - 3) + 3587$$

The data is represented as follows:

**Register address**

High byte = Channel 2		Low byte = Channel 1
-----------------------	--	----------------------

**Register address+1**

High byte = Channel 4		Low byte = Channel 3
-----------------------	--	----------------------

**RPI devices with a maximum of 8 channels with status, 4 registers per RPI device**

The data from 1-, 2-, 4- or 8 channel devices are filed in this area. 4 registers must be read in order to obtain the complete information for all channels.

The address is obtained from the following equation:

$$\text{Address} = 4 * (\text{RPI address} - 3) + 3084$$

The data is represented as follows:

**Register address**

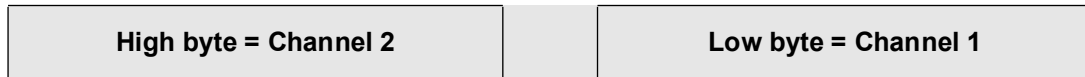

**Register address+1**



**Register address+2**



**Register address+3**



The data from channels which are not available is set to 0.

**7.3.9 Reading Analogue Input Data without Status**

All analogue values are represented in signed integer format (16 bit) and in floating point format in accordance with "IEEE 754 short real number".



In the signed integer format, the number of places after the decimal point depends on the RPI module. The KSD2-TI-Ex universal temperature converter operates with one, all others operate with 2 places after the decimal point.

In signed integer format, the data is represented as follows::

Device type	Register content	Meaning
KSD2-FI-Ex2	327d	327
KSD2-TI-Ex	327d	32.7
	327d	3.27

The statement of the register contents is in decimal format. The values in the meaning column are given units. These can be set by means of the **PACT<sup>ware</sup>**™ or K-SK1 configuration software. Further information is provided in the description of the **PACT<sup>ware</sup>**™ software or in Section 12 of this handbook.



Analogue input data is usually read from the input registers of a Modbus station by PLC's or process control systems. In exceptional cases, it may be that control of access to the input register is not supported. In this case, the correct register address can be obtained from Chapter 7.3.13.

**Reading analogue input data, 1 channel devices**

This data is deposited in register table 4, which can be read via function code 04.

The register address is dependent on the RPI internal address of the device. It can be derived from the following equations:

Data format	Register address
Signed integer	RPI address+4608
Floating point	$2 \times (\text{RPI address} - 3) + 6150$

In the signed integer format, only one register must be read. In the floating point format, two registers must be read. The data is structured as follows:

Register address+1		Register address	
Data byte 4	Data byte 3	Data byte 2	Data byte 1

**Reading analogue input data, 2 channel devices**

All measured values from 1 and 2 channel devices are represented in this area, as a function of the current RPI address. The register addresses can be obtained from the following equations:

Data format	Register address
Signed integer	$2 \times (\text{RPI address} - 3) + 5126$
Floating point	$4 \times (\text{RPI address} - 3) + 7052$

Two registers must be read in the signed integer format. The data is constructed as follows:

Register address+1	Register address
Channel 2	Channel 1

Four registers must be read in the floating point format. These are constructed as follows:

**Channel 1**

Register address+1		Register address	
Data byte 4	Data byte 3	Data byte 2	Data byte 1

**Channel 2**

Register address+3		Register address+2	
Data byte 4	Data byte 3	Data byte 2	Data byte 1

Data for unoccupied channels is set to 0.

**Reading analogue input data, 3 channel devices**

All measured values from 1-, 2- and 3 channel devices are given in this area as a function of the current RPI address. The register addresses can be obtained from the following equations:

Data format	Register address
Signed integer	$3 \times (\text{RPI address} - 3) + 12$
Floating point	$6 \times (\text{RPI address} - 3) + 8210$

In the signed integer format, 3 registers have to be read. The data is constructed as follows:

Register address+2	Register address+1	Register address
Channel 3	Channel 2	Channel 1

6 registers have to be read in the floating point format. These are constructed as follows:

**Channel 1**

Register address+1		Register address	
Data byte 4	Data byte 3	Data byte 2	Data byte 1

**Channel 2**

Register address+3		Register address+2	
Data byte 4	Data byte 3	Data byte 2	Data byte 1

**Channel 3**

Register address+5		Register address+4	
Data byte 4	Data byte 3	Data byte 2	Data byte 1

Data for unoccupied channels is set to 0.

**7.3.10 Reading Analogue Input Data with Status**

The status information occupies one register per channel, of which 7 bits are used for the analogue data. The structure of the status register is as follows:

0	0	0	0	0	0	0	0	GW2	GW1	CD3	CD2	CD1	Q2	Q1	Dat
---	---	---	---	---	---	---	---	-----	-----	-----	-----	-----	----	----	-----

Bit 0 of the low byte (Dat) is always set to 0.

Bits GW1 and GW2 are reserved for limit value monitoring.

CD1 to CD3 code the error that has occurred.

Q1 and Q2 provide information on signal quality.

The messages shown in the table below are generated instantaneously.

Meaning	GW2	GW1	CD3	CD2	CD1	Q2	Q1	Dat
Good							0	0
Not certain						0	1	0
Bad			0	0	0	1	0	0
Good, no error			0	0	0	0	0	0
Measurement range exceeded/fallen short			0	1	1	0	1	0
Simulated measured value			1	0	1	0	1	0
Reserved			1	1	0	0	1	0
Configuration error			0	0	1	1	0	0
RPI device error			0	1	0	1	0	0
Field device error			1	0	0	1	0	0
No communication (last good value)			1	0	1	1	0	0
No limit value reached	0	0						0
Lower limit violated	0	1						0
Upper limit violated	1	0						0

Date of issue 05/27/03

**Reading analogue input data, 1 channel devices**

All the measured values from single channelled devices are represented in this area as a function of the current RPI address. The register addresses can be obtained from the following equations:

Data format	Register address
Signed integer	$2 \cdot (\text{RPI address} - 3) + 4742$
Floating point	$3 \cdot (\text{RPI address} - 3) + 6409$

Two registers have to be read in the signed integer format. The data is constructed as follows:

Register address+1	Register address
Status	Channel 1

In the floating point format, 3 registers have to be read. These are constructed as follows:

Register address+1	register address
Data byte 2	Data byte 1
	Not used
	Status
Register address+2	
Data byte 4	Data byte 3

**Reading analogue input data, 2 channel devices**

All the measured values from 1 or 2 channelled devices are represented in this area as a function of the current RPI address. The register addresses can be obtained from the following equations:

Data format	Register address
Signed integer	$3 \cdot (\text{RPI address} - 3) + 5641$
Floating point	$5 \cdot (\text{RPI address} - 3) + 7567$

3 registers have to be read in the signed integer format. The data is constructed as follows:

Register address+1	Register address
Channel 1	Status Channel 2
	Status Channel 1
Register address+2	
Channel 2	

5 registers have to be read in the floating point format. These are constructed as follows:

Register address+1	Register address
Channel 1, Data word 1	Status Channel 2
	Status Channel 1
Register address+3	Register address+2
Channel 2, Data word 1	Channel 1, Data word 2
Register address+4	
Channel 2, Data word 2	

Date of issue 05/27/03

**Reading analogue input data, 3 channel devices**

All the measured values from 1, 2 or 3 channelled devices are represented in this area as a function of the current RPI address.. The register addresses can be obtained from the following equations:

Data format	Register address
Signed integer	$6 * (\text{RPI address} - 3) + 2072$
Floating point	$8 * (\text{RPI address} - 3) + 536$

If all the information from a device is to be read in signed integer format, 6 registers have to be read. Access to one channel can be achieved by the addition of the term:  $2 * (\text{Channel number} - 1)$ . The data is constructed as follows:

Register address+1	Register address
Channel 1	Status Channel 1
Register address+3	Register address+2
Channel 2	Status Channel 2
Register address+5	Register address+4
Channel 3	Status Channel 3

8 registers have to be read in the floating point format. These are constructed as follows:

Register address+1	Register address
Status Channel 2	Status Channel 1
Not used	Status Channel 3
Register address+3	Register address+2
Channel 1, Data word 2	Channel 1, Data word 1
Register address+5	Register address+4
Channel 2, Data word 1	Channel 2, Data word 1
Register address+7	Register address+6
Channel 3, Data word 2	Channel 3, Data word 1

**7.3.11 Writing/Reading Analogue Output Data without Status**

All analogue values are represented in signed integer format (16 bit) and in floating point format in accordance with "IEEE 754 short real number".



On the output modules, in signed integer format, the number of places after the decimal point is 2.

Note

Device type	Register content	Meaning
KSD2-CO-Ex	327d	3.27

The content of the register is given in decimal format. The values in the Meaning column are in units. These can be set using the **PACTware™** edition 2 software.



Note

If your control system does not support access to the input registers (Table 04), the register addresses can be obtained from Chapter 7.3.13.

**Writing/reading analogue output data, 1 channel devices**

This data is deposited in register table 3, which can be read via the function code 03 and written to via function code 05 (Preset Single Register) and function code 16 (Preset Multiple Register).

The register address is dependent on the RPI internal address. It can be derived from the following equations:

Data format	Register address
Signed integer	RPI address+4608
Floating point	2*(RPI address-3)+6150

In the signed integer format, only 1 register must be read and written to.

In the floating point format, 2 registers have to be read/written in order to access the data from an RPI device. The floating point format data is structured as follows:

Register address+1		Register address	
Data byte 4	Data byte 3	Data byte 2	Data byte 1

**Writing/reading analogue output data, 2 channel devices**

All the measured values from 1 and 2 channelled devices are represented in this area as a function of the current RPI address. The register addresses can be obtained from the following equations:

Data format	Register address
Signed integer	2*(RPI address-3)+5126
Floating point	4*(RPI address-3)+7052

In the signed integer format, 2 registers have to be read/written in order to access the data from an RPI device. The data is constructed as follows:

Register address+1	Register address
Channel 2	Channel 1

In the floating point format, 4 registers have to be read/written in order to access the data from an RPI device. The data is constructed as follows:

**Channel 1**

Register address+1	Register address
Channel 2	Channel 1

**Channel 2**

Register address+3	Register address+2
Channel 2	Channel 1

Data for unoccupied channels is set to 0.

Date of issue 05/27/03

**Writing/reading analogue input data, 3 channel devices**

All measured values from 1-, 2- and 3 channelled devices are represented in this area as a function of the current RPI address. The register addresses can be obtained from the following equations:

Data format	Register address
Signed integer	$3*(RPI\ address-3)+12$
Floating point	$6*(RPI\ address-3)+8210$

In the signed integer format, 3 registers have to be read/written per device. The data is constructed as follows:

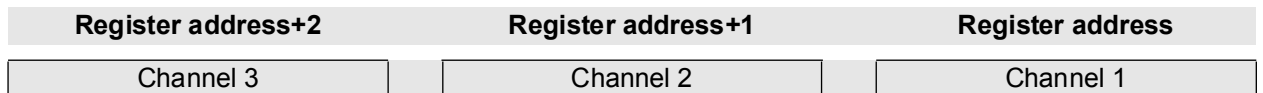

In the floating point format, 6 registers have to be read per device. The data is constructed as follows:

**Channel 1**

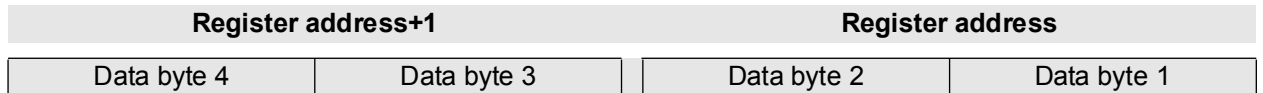

**Channel 2**



**Channel 3**



Data for unoccupied channels is set to 0.

**7.3.12 Writing/Reading Analogue Output Data with Status**

Reference should be made to Chapter 7.1. of this handbook for the structure of the status information.

**Writing/reading analogue input data, 1 channel devices**

All measured values from 1 channelled devices are represented in this area, as a function of the current RPI address. The register addresses can be obtained from the following equations:

Data format	Register address
Signed integer	$2*(RPI\ address-3)+4742$
Floating point	$3*(RPI\ address-3)+6409$

In the signed integer format, 2 registers have to be read. The data is constructed as follows::



Date of issue 05/27/03

In the floating point format, 3 registers have to be read. These are constructed as follows:

Register address+1		Register address	
Data byte 2	Data byte 1	Not used	Status
Register address+2			
Data byte 4	Data byte 3		

### Writing/reading analogue output data, 2 channel devices

All measured values from 1 or 2 channelled devices are represented in this area, as a function of the current RPI address. The register addresses can be obtained from the following equations:

Data format	Register address
Signed integer	$3 \cdot (\text{RPI address} - 3) + 5641$
Floating point	$5 \cdot (\text{RPI address} - 3) + 7567$

3 registers have to be read in the signed integer format. The data is constructed as follows:

Register address+1		Register address	
Channel 1		Status Channel 2	Status Channel 1
Register address+2			
Channel 2			

5 registers have to be read in floating point format. These are constructed as follows:

Register address+1		Register address	
Channel 1, Data word 1		Status Channel 2	Status Channel 1
Register address+3		Register address+2	
Channel 2, Data word 1		Channel 1, Data word 2	
Register address+4			
Channel 2, Data word 2			

### Writing/reading analogue output data, 3 channel devices

All measured values from 1-, 2- and 3 channelled devices are represented in this area, as a function of the current RPI address. The register addresses can be obtained from the following equations:

Data format	Register address
Signed integer	$6 \cdot (\text{RPI address} - 3) + 2072$
Floating point	$8 \cdot (\text{RPI address} - 3) + 536$

If all the information from a device is to be read in signed integer format, 6 registers have to be read. Access to one channel can be achieved by adding the term:  $2 \cdot (\text{Channel number} - 1)$ . The data is constructed as follows:

Register address+1	Register address
Channel 1	Status Channel 1
Register address+3	Register address+2
Channel 2	Status Channel 2
Register address+5	Register address+4
Channel 3	Status Channel 3

In the floating point format, 8 registers have to be read. These are constructed as follows:

Register address+1	Register address
Status Channel 2	Status Channel 1
Not used	Status Channel 3
Register address+3	Register address+2
Channel 1, Data word 2	Channel 1, Data word 1
Register address+5	Register address+4
Channel 2, Data word 1	Channel 2, Data word 1
Register address+7	Register address+6
Channel 3, Data word 2	Channel 3, Data word 1

### 7.3.13 Special case: Holding Register



This section deals with the special case in which the host (PLC or control system) does not support access to the input register (Table 04).. In this case, the analogue input data is imaged in holding registers (Table 03).

Note



In order to have access to the analogue input data, the register address 0 (Table Select) in Table 03, must be set to the value FF<sub>hex</sub>. The standard setting is 0!

Note

If the gateway is operated in this mode, some gateway diagnostic functions and configuration options are not available.

#### Reading analogue input data

All analogue values are represented in signed integer format (16 bit) and in floating point format in accordance with

"IEEE 754 short real number".

In the signed integer format, the data is represented as follows:

Device type	Register content	Meaning
KSD2-FI-Ex2	327d	327
KSD2-TI-Ex	327d	32.7
all others	327d	3.27

The statement of the register contents is in decimal format. The values in the meaning column are given units. These can be set using the configuration software.

### Reading analogue input data, 1 channel devices

This data is deposited in register table 3, which can be read via function code 03.

The register address is dependent on the RPI internal address It can be derived from the following equations:

Data format	Register address
Signed integer	RPI address+1248
Floating point	$2 \cdot (\text{RPI address} - 3) + 1376$

Only 1 register has to be read in the signed integer format.

In the floating point format, 2 registers have to be read. The data is structured as follows:

Register address+1		Register address	
Data byte 4	Data byte 3	Data byte 2	Data byte 1

### Reading analogue input data, 2 channel devices

All measured values from 1 and 2 channelled devices are represented in this area as a function of the current RPI address. The register addresses can be obtained from the following equations:

Data format	Register address
Signed integer	$2 \cdot (\text{RPI address} - 3) + 1626$
Floating point	$4 \cdot (\text{RPI address} - 3) + 1876$

In signed integer format, 2 registers have to be read. The data is constructed as follows:

Register address+1	Register address
Channel 2	Channel 1

4 registers have to be read in the floating point format. These are constructed as follows:

#### Channel 1

Register address+1		Register address	
Data byte 4	Data byte 3	Data byte 2	Data byte 1

#### Channel 2

Register address+3		Register address+2	
Data byte 4	Data byte 3	Data byte 2	Data byte 1

Data for unoccupied channels is set to 0.

### Reading status information

The status information is filed in separate registers. A register is always assigned to a particular RPI device, that can have up to two channels. The register address can be obtained as follows:

**Register address = RPI address + 2373**

The data is structured as follows:

High byte	Low byte
Status Channel 2	Status Channel 1

The significance of the individual bits is given in Section 7.3.10

**Writing/reading analogue output data**

All analogue values are represented in signed integer format (16 bit) and in floating point format in accordance with

"IEEE 754 short real number".

On the output modules, in signed integer format, the number of places after the decimal point is 2.

Device type	Register content	Meaning
KSD2-CO-Ex	327d	3.27

The statement of the register contents is in decimal format. The values in the meaning column are given units. These can be set using the human machine interface.

**Writing/reading analogue output data, 1 channel devices**

This data is deposited in register table 3, which can be read via function code 03 and written to via function code 05 (Preset Single Register) and function code 16 (Preset Multiple Register).

The register address is dependent on the RPI internal address It can be derived from the following equations:

Data format	Register address
Signed integer	RPI address 2
Floating point	2*(RPI address-3)+126

In the signed integer format, only 1 register must be read and written to. In floating point format, 2 registers have to be read/written to in order to access the data from an RPI device. The floating point format data is structured as follows:

Register address+1		Register address	
Data byte 4	Data byte 3	Data byte 2	Data byte 1

**Writing/reading analogue output data, 2 channel devices**

All measured values from 1 and 2 channelled devices are represented in this area as a function of the current RPI address. The register addresses can be obtained from the following equations:

Data format	Register address
Signed integer	$2 \cdot (\text{RPI address} - 3) + 376$
Floating point	$4 \cdot (\text{RPI address} - 3) + 626$

2 registers have to be read/written to in signed integer format, in order to access the data from an RPI device. The data is constructed as follows:



In the floating point format, 4 registers have to be read/written to, in order to access the data of an RPI device. The data is constructed as follows:

**Channel 1**



**Channel 2**



Data for unoccupied channels is set to 0.

**Reading status information**

The status information is filed in separate registers. One RPI is always allocated to one register and can have up to 2 channels. The register address can be obtained as follows:

**Register address = RPI address + 1126**

The data is structured as follows:

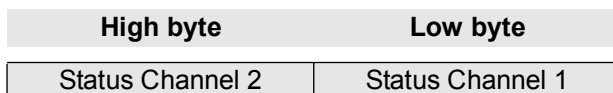

The meaning of the individual bits is given in Section 7.3.10

**Reading binary inputs with status**

This information is deposited in register table 3 for up to 4 channelled devices. The register address can be obtained from the following equation:

**Register address = 2\*(RPI address-3)+2751**

The data is constructed as follows:

Register address+1		Register address	
Data byte 4	Data byte 3	Data byte 2	Data byte 1

The meaning of the individual bits is given in Section 7.3.6.

**Writing/reading binary outputs with status**

This information is deposited in register table 3 for up to 4 channelled devices. The register address can be obtained from the following equation:

**Register address = 2\*(RPI address-3)+2501**

The data is constructed as follows:

Register address+1		Register address	
Data byte 4	Data byte 3	Data byte 2	Data byte 1

The meaning of the individual bits is given in Section 7.3.6. It should be noted that the status bits cannot be written.

**7.3.14 Configuring an RPI System via the Host**

It is possible to configure an RPI system via the host (PLC or control system) and to read the current configuration. In so doing, the following information must be transmitted to the gateway/ read:

- Device ID
- Device type
- Parameter values for each device (measuring range, with or without lead breakage/short circuit monitoring, etc.)

The following table shows the relationship between RPI device, device ID and device type:

Device	Device ID	Device type
KSD2-GW-MOD	82h	--
KSD2-TI-Ex	01h	0140h
KSD2-CI-Ex	02h	0140h
KSD2-BI-Ex2	03h	0111h
KSD2-BO-Ex	04h	0120h
KSD2-CI-S-Ex	05h	0540h
KSD2-CO-Ex	06h	0180h
KSD2-BI-Ex4	07h	0113h
KSD2-BO-Ex2	08h	0121h
KSD2-CI-2	0Ah	0120h
KSD2-CO-S-Ex	0Bh	0180h
KSD2-BI-4	0Dh	0113h
KSD2-RO-Ex2	0Eh	0121

Date of issue 05/27/03

The device-ID and the device type is stored as a function of the RPI address.  
The register addresses are obtained as follows:

**Device ID**

**Register address = RPI address + 4096**

**Device type**

**Register address = RPI address + 4224**

The parameter values can be accessed or written to via an acyclic channel. These values are then exchanged via 2 mailboxes (host ? RPI or RPI ? host).

Further information on this functional procedure can be obtained directly from Pepperl+Fuchs.

**7.3.15 Diagnosis**

Channel-based diagnosis can be supported by read-out of the corresponding status information.

In addition to this information, register table 4 provides device-based data:

**Register address = RPI address + 4225**

Bit 0	E <sup>2</sup> PROM error
Bit 1	Internal interface error
Bit 2	Internal interface error
Bit 3	TIN Time Out
Bit 4	Common mode active
Bit 5	Local access (e.g., HART communication)
Bit 6	Reserved
Bit 7	Reserved
Bit 8	RPI system is in the run-up phase
Bit 9	Reserved
Bit 10	Reserved
Bit 11	Is set, if re-addressing has taken place within the last 5 seconds
Bit 12	Is set, if the current device address has been checked within the last second
Bit 13	Reserved
Bit 14	Reserved
Bit 15	Reserved

The gateway diagnostic information is deposited bitwise in register addresses 8 to 23 in Table 2 or wordwise in register addresses 8, 528, 1538, 2064, 3080 and 4225. The individual bits have the following meaning:

<b>Table 2 Register adr.</b>	<b>Register addresses 8, 528, 1538, 2064, 3080 and 4225</b>	<b>Meaning</b>
8	Bit No. 0	E <sup>2</sup> PROM Fehler
9	Bit No. 1	Internal interface error
10	Bit No. 2	Watchdog
11	Bit No. 3	TIN Time Out
12	Bit No. 4	Communication mode (switch-over from differential to common mode)
13	Bit No. 5	Local access (e.g., HART protocol)
14	Bit No. 6	Reserved
15	Bit No. 7	Reserved
16	Bit No. 8	RPI configuration error (1 or more devices too many)
17	Bit No. 9	RPI configuration error (1 or more devices missing)
18	Bit No. 10	RPI configuration error (1 or more incorrect device ID's)
19	Bit No. 11	RPI configuration error, device-specific
20	Bit No. 12	RPI configuration error, channel-specific
21	Bit No. 13	1 = switch-over of the redundant gateway to active mode, if automatic switch-over has not been selected
22	Bit No. 14	Redundant mode 0 = passive; 1 = active
23	Bit No. 15	Reserved

Error codes are given in Appendix A, which are indicated in mode A on the gateway display. These error codes can be read from register table 4

**Register address = RPI address + 4355**

If the status of the RPI system is changed, e.g., through a change in the configuration, device error or channel error, a counter is incremented. This 8 bit counter can be read from register table 4.

**Register address = 4480**

## 7.3.16 Summary of Tables

## Binary inputs without status

	Reg.Tab.	Register address
Channel-based, max. 8 channels	2	8*RPI address + channel number -1
Channel-based, max. 4 channels	2	4*(RPI address - 3) + channel number + 1035
Device-based, max. 8 channels, 1 device per register	4	RPI address + 1536
Device-based, max. 4 channels, 4 devices per register	4	Int[(RPI address-3)/4] + 9216
Device-based, max. 8 channels, 2 devices per register	4	Int[(RPI address 2)/2] + 9345
Device-based, max. 4 channels, 2 registers per device	4	
Device-based, max. 8 channels, 4 registers per device	4	

## Binary inputs with status

	Reg.Tab.	Register address
Device-based, max. 4 channels, 2 registers per device	4	2*(RPI address-3) + 3587
Device-based, max. 8 channels, 4 registers per device	4	4*(RPI address-3) + 3084

## Binary outputs without status

	Reg.Tab	Register address
Channel-based, max. 8 channels	1	8*RPI address + channel number - 1
Channel-based, max. 4 channels	1	4(RPI address - 3) + channel number + 1035
Device-based, max. 8 channels, 2 devices per register	3	Int[(RPI address 2)/2] + 9345
Device-based, max. 4 channels, 4 devices per register	3	Int(RPI address/4) + 9216

## Binary outputs with status

	Reg.Tab	Register address
Device-based, max. 4 channels, 2 registers per device	3	2*(RPI address-3) + 3587
Device-based, max. 8 channels, 4 registers per device	3	4*(RPI address-3) + 3084

## Analogue inputs without status

	Reg.Tab	Signed integer format	Floating point format
Analogue inputs, 1 channel device	4	RPI address+4608	2*(RPI address-3)+6150
Analogue inputs, 2 channel device	4	2*(RPI address-3)+5126	4*(RPI address-3)+7052
Analogue inputs, 3 channel device	4	3*(RPI address-3)+12	6*(RPI address-3)+8210

**Analogue inputs with status**

	Reg.Tab.	Signed integer format	Floating point format
Analogue inputs, 1 channel device	4	2*(RPI address-3)+4742	3*(RPI address-3)+6409
Analogue inputs, 2 channel device	4	3*(RPI address-3)+5641	5*(RPI address-3)+7567
Analogue inputs, 3 channel device	4	6*(RPI address-3)+2072	8*(RPI address-3)+536

**Analogue outputs without status**

	Reg.Tab	Signed integer format	Floating point format
Analogue outputs, 1 channel device	3	RPI address+4608	2*(RPI address-3)+6150
Analogue outputs, 2 channel device	3	2*(RPI address-3)+5126	4*(RPI address-3)+7052
Analogue outputs, 3 channel device	3	3*(RPI address-3)+12	6*(RPI address-3)+8210

**Analogue outputs with status**

	Reg.Tab	Signed integer format	Floating point format
Analogue outputs, 1 channel device	3	2*(RPI address-3)+4742	3*(RPI address-3)+6409
Analogue outputs, 2 channel device	3	3*(RPI address-3)+5641	5*(RPI address-3)+7567
Analogue outputs, 3 channel device	3	6*(RPI address-3)+2072	8*(RPI address-3)+536

**Special case - holding register, binary input or output data**

Binary inputs with status, max. 4 channels	2*(RPI address-3)+2751
Binary outputs with status, max. 4 channels	2*(RPI address-3)+2501

**Special case - holding register, analogue input or output data and status information**

	Signed integer	Floating point
Analogue inputs, 1 channel device	RPI address+1248	2*(RPI address-3)+1376
Analogue inputs, 2 channel device	2*(RPI address-3)+1626	4*(RPI address-3)+1876
Analogue outputs, 1 channel device	RPI address 2	2*(RPI address-3)+126
Analogue outputs, 2 channel device	2*(RPI address-3)+376	4*(RPI address-3)+626
Status information	RPI address + 1126	

**Other available register addresses**

	Reg.Tab.	Register address
Device ID	3	RPI address + 4096
Device type	3	RPI address + 4224
Device diagnosis	4	RPI address + 4225
Gateway diagnosis, wordwise	4	8, 528, 1538, 2064, 3080 and 4225
Gateway diagnosis, bitwise	2	8 - 23

## 7.4 Gateways for the MODBUS Plus

### 7.4.1 Gateways KSD2-GW-MPL and KSD2-GW-MPL.485

The KSD2-GW-MPL and KSD2-GW-MPL.485 gateways supports the command and response telegram, in accordance with MODICON Modbusprotokoll, Reference Guide, PI-MBUS-300 Rev.D. The KSD2-GW-MPL gateway is provided with an RS232 service interface, whereas the KSD2-GW-MPL.485 gateway has an RS 485-interface. The operating level consists of an LC-display with 3 1/2 digits and the three buttons "Mode", "Up" and "Down".

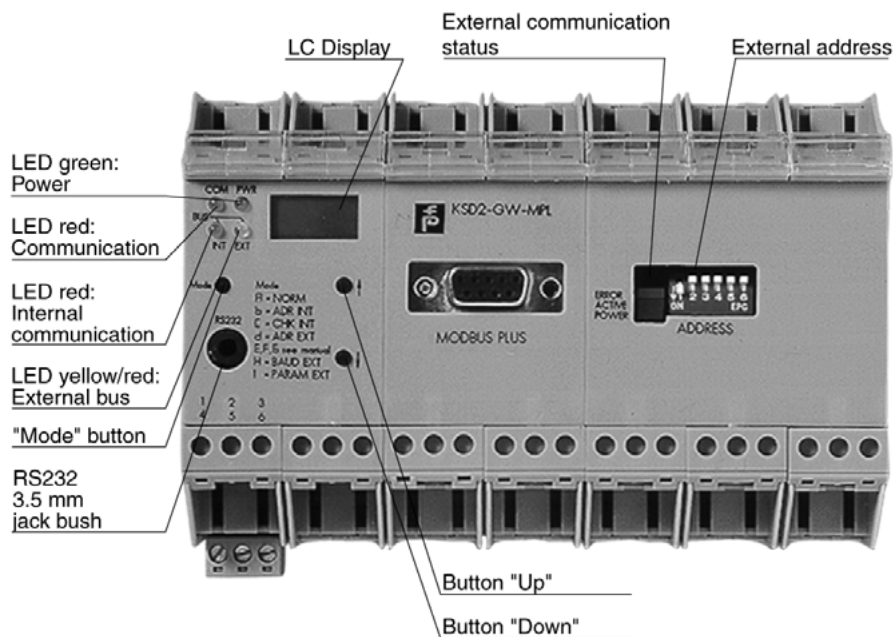

Figure 7.4:KSD2-GW-MPL gateway

### Features of KSD2-GW-MPL / KSD-GW-MPL.485 Gateways

The KSD2-GW-MPL and KSD-GW-MPL.485 gateway connects the RPI internal bus to the external MODBUS Plus. The gateway thus assumes the master function for the internal bus. The gateway has the function of a slave device on the external Modbus Plus. To increase system availability, the gateway and the external bus can be implemented in a redundant configuration. The transmission rate of the Modbus Plus bus is 1 Mbps (Megabit per second).

### 7.4.2 Device Connection

The electrical connection of the KSD2-GW-MPL Modbus gateways by means of cables with 9-pin Sub-D connectors, merely involves establishing the Modbus Plus connection. The Modbus interface is an RS 485 interface, on which up to 64 stations can be operated.

The parameterization interface can be either an RS232 (KSD2-GW-MPL) or an RS485 interface (KSD2-GW-MPL.485); it is used to configure the RPI system with the PACTware™ edition 2 or the K-SK1 human machine interface. To do this, the PC is connected to the gateway via the service interface.

If an RS 232 interface is available, connection to the PC can be made via the K-ADP2 adapter. A jack socket is provided on the front of the gateway for this purpose. If the PC is to remain connected to the RPI system as a configuring and monitoring system, it is recommended that connection is made via the plug-in screw terminals 7, 8 and 9 using the K-ADP4 adapter.

On the KSD2-GW-MOD.485 gateway, with the RS 485 program interface only the terminal connection is available.

The complete configuration of the RPI system can also be undertaken from the control system, via the Modbus, providing that the control system supports this.



The jack socket on the front and the screw terminal connection for the RS 232 link cannot be used simultaneously.

**Note**

Connection to the 24 V DC supply and to the internal CAN bus is achieved via the Power Rail.

The cable connections are made via self-opening screw terminals; max. core cross-section 1 x 2.5 mm<sup>2</sup> for rigid cables or 2 x 1.5 mm<sup>2</sup> for flexible cables with plastic wire end ferrules. The screw terminal blocks on the device can be removed for ease of connection.

Mount the gateway on the Power Rail and connect the Modbus cable and, if necessary, the RS232/RS485 cable as described in the connection plan and the terminal assignment list.

The connection plan for the RS232 or RS485 gateway can be obtained from the current issue of the "Interface DIN-Rail Housing" catalogue.

### Sub-D connector

Terminal	KSD2-GW-MOD	KSD2-GW-MOD.485
1	Screen, RS 485	Screen, RS 485
2	RxD/TxD-P, RS485 param. interface	RxD/TxD-P, RS485 param. interface
3	RxD/TxD-N, RS485 param. interface	RxD/TxD-N, RS485 param. interface

### Terminal assignment

Terminal	KSD2-GW-MOD	KSD2-GW-MOD.485
7	RxD, RS232 param. interface	RxD/TxD-P, RS485 param. interface
8	TxD, RS232 param. interface	RxD/TxD-N, RS485 param. interface
9	GND, RS232	GND, RS485
13	Screen, RS232	Screen, RS 485
14	Screen, RS232	Screen, RS485
15	Earth	Earth



The number of stations on one RS485 interface (Modbus interface, such as the RS 485 program interface) is a maximum of 32, as standard.

**Note**

The maximum length of lead on a bus segment is effectively determined by the following parameters:

- Type of bus cable used
- Transfer rate
- External interference effects
- Number of bus stations

More detailed information on the determination of the maximum lead length can be obtained from the EIA 485 or ISO 8482.

### Bus termination



On the Modbus Plus, each bus segment must be terminated by resistances at both ends of the line.

**Note**

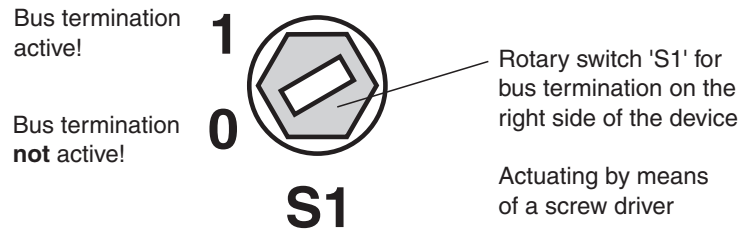

Figure 7.5: Rotary switch S1 for bus termination

The Modbus gateways operate internally via a switchable bus termination. Using a screwdriver, the bus termination can be activated on the rotary switch S1 on the right side of the housing (as viewed from the front). This is used if the gateway is installed at the end of a line.

**7.4.3 Modbus Plus address**

The address is set by the 6 dip switches on the front of the gateway marked "NODE ADD." Possible Modbus Plus addresses are 1 through 64. The coding of the DIP-switches is indicated on the housing side. A switch in the down, or ON, position is a logic '0' and conversely a switch in the up, or OFF, position is a logic '1'.



Note

The number of stations on one RS485 interface (Modbus interface, such as the RS 485 service interface) is a maximum of 31, as standard.

**7.4.4 Commissioning**

Before commissioning, check once again that all the connections are correct.

Familiarise yourself with the method of communication between the Modbus Plus master and the gateway. Commissioning requires a knowledge of the Modbus Plus and the parameter assignment of the Modbus Plus gateway.

**Time response**

The Remote Process Interface is deterministic. The RPI devices are interrogated cyclically.

The most important factors which determine the time response are:

- the higher level host system, e.g. process control system, PLC or PC
- the type and number of Modbus Plus stations
- the number of the RPI devices and the cycle time of the RPI system
- the user program

**7.4.5 Data Transfer on the Modbus Plus**

**Modbus Plus functions**

The Modbus Plus is a register-orientated bus system. This means that the data is automatically stored in a memory area, the so-called registers of the Modbus Plus gateways. Modbus Plus supports the Modbus RTU functions, which are listed in the table below. The user can access specific data by reading the registers, and set targeted outputs or interrogate diagnoses by writing to these registers.

Code	Function	Description
03	Read Holding Registers	Reading write/read registers, e.g. analogue outputs, acyclic parameter channels
16	Preset Multiple Registers	Block-wise writing of analogue outputs or acyclic parameter channels

Date of issue 05/27/03

**Data transfer**

In the RPI gateway there are two 256-word registers which are accessible to the Modbus Plus master. The Read Holding Register starts with register No. 1 and the Write Holding Register starts with register No. 1025. The data in the Write Holding Register is written by the host via the 'Preset Multiple Registers' function, while the data in the Read Holding Register is read via the 'Read Holding Registers' function. Both Read Holding Register and Write Holding Register are divided into two sections: a Control Register Area (first 10 registers) and a Data Register Area (remaining 246 registers).

Write Holding Register		Read Holding Register			
Register	Area	Register	Area		
1025	Control Register Area	1	Control Register Area		
1026		2			
...		...			
1034		10			
1035		Data Register Area		11	Data Register Area
1036				12	
...				...	
1280				256	

Figure 7.6: Read/Write Holding Register Configuration

Generally the Control Register Area is used for the Modbus Plus master device to send commands and read responses to or from the RPI gateway.

**7.4.6 Structure of Control Register Areas**

**Write Holding Register (registers 1025 - 1034)**

Of the ten registers available only the first register (No. 1025) is used to transfer commands. The remaining registers are not used and contain '0'.

Register	Description of Write Holding Register
1025	HOST command register - used for commands to be sent to the Modbus Plus gateway.
1026 ... 1034	- not used and should be cleared to '0'

Modbus Plus supports the eight HOST commands listed below. Further details can be found in the 'Modbus Plus Gateway - User Manual'.

- HOST command 1: Exchange data
- HOST command 2: Set I/O data structure
- HOST command 3: Set redundancy mode
- HOST command 4: Read module diagnosis
- HOST command 5: Single channel function diagnostics
- HOST command 6: Read error code and channel alarms
- HOST command 7: Read gateway ID list
- HOST command 8: Read RPI system module types

Date of issue 05/27/03

Read Holding Register (registers 1 - 10)

Register	Byte	Description of Read Holding Register	
1	High	0	
	Low	Host Command - Ack Register: echo of the Host Command register to verify if this is the response to the latest host command.	
2	High	0	
	Low	Response Counter - Modbus Plus data register update in the RPI Gateway. The RPI Modbus Plus may response to a single Host Command periodically. The Response Counter is incremented by one for each response. For each new Host Command, the counter counts starting from 1.	
3	High	0	
	Low	RPI Status Counter - a counter for status change of the RPI. A change in the counter indicates either an error status change in ERROR_CODE_LIST or a channel alarm status change in CHANNEL_ALARM_LIST.	
4	High	0	
	Low	RPI Parameter Counter - a counter for gateway parameter change.	
5	High	Low	
		RPI configuration error Bit 0: RPI configuration error Bit 1: reserved Bit 2: reserved Bit 3: RPI device error Bit 4: RPI channel error Bit 5: Redundant circuit Bit 6: Redundant mode Bit 7: Parameter check	Gateway diagnosis Bit 0: E2PR_Err Bit 1: APPL_Err Bit 2: WATCHDOG Bit 3: TIMEOUT_COM Bit 4: not used Bit 5: not used Bit 6: not used Bit 7: reserved
6...10		reserved	

Further information about the 'Functional Commands' and the tools can be obtained from the 'Modbus Plus Gateway - User Manual'.

## 7.5 Gateways for ControlNet

### 7.5.1 KSD2-GW-CN and KSD2-GW-CN.485 Gateways

The KSD2-GW-CN and KSD2-GW-CN.485 gateways are designed in accordance with the international ControlNet specification for 'Communication Adapters' (profile No. 12). The KSD2-GW-CN gateway has an RS 232 service interface while the gateway of the type KSD2-GW-CN.485 has an RS 485 interface. The operating level consists of an LC-display with 3 1/2 digits and of the three pushbuttons "Mode", "Up" and "Down".

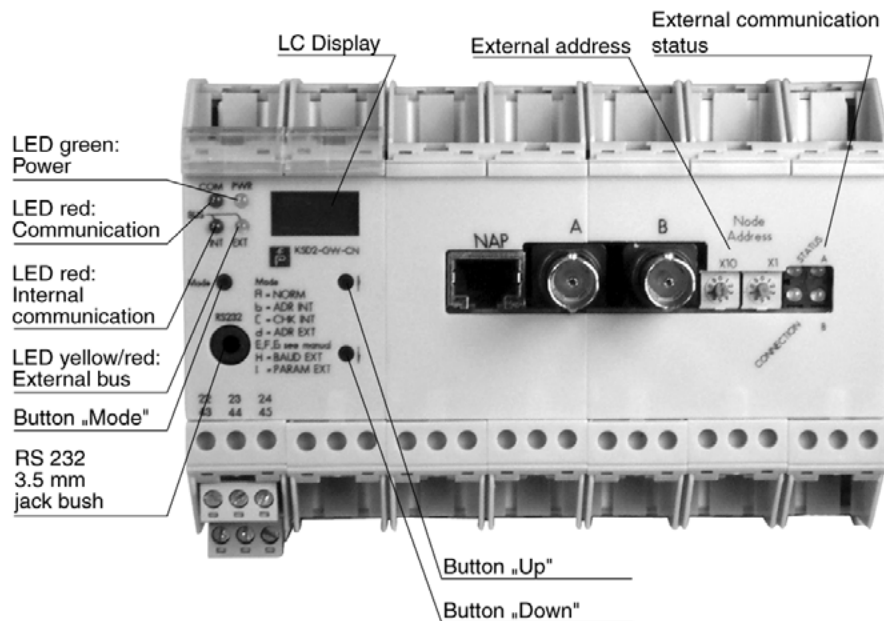

Figure 7.7:KSD2-GW-CN gateway

#### Features of the KSD2-GW-CN / KSD-GW-CN.485 gateways

The KSD2-GW-CN and KSD2-GW-CN.485 gateways connect the RPI internal bus to the external ControlNet bus. The gateway thus assumes the master function for the internal bus. The gateway has the function of a ControlNet adapter (slave) on the external ControlNet. To increase system availability, the gateway and external bus can be arranged redundantly.

The gateway is provided with two BNC plugs for the connection to the ControlNet. The cable to the 'Scanner node' (ControlNet host) may be arranged redundantly by using both connectors ('A' and 'B'). The MacID (ControlNet Node address) can be set by means of the two decimal rotary switches, before switching on the power supply. The address range is 1 through 99.

A configuration tool for system configuration or problem solving can be connected using the NAP interface (Network Access Port).

### 7.5.2 Device connection

The electrical connection of the ControlNet gateway by means of a BNC plug and a RG-6 four-core screened cable, merely involves establishing the ControlNet connection. The ControlNet address is set by the two rotary switches. Possible addresses are 1 through 99.

The RPI service interface can be either an RS 232 (KSD2-GW-CN) or an RS 485 interface (KSD2-GW-MPL.485); it is used to configure the RPI system with the **PACTware**<sup>TM</sup> edition 2 human machine interface. To do this, the PC is connected to the gateway via the service interface.

If an RS 232 interface is available, connection to the PC can be made via the K-ADP2 adapter. A jack socket is provided on the front of the gateway for this purpose. If the PC is to remain permanently connected to the RPI system as a configuring and monitoring system, it is recommended that connection is made via the

plug-in screw terminals 7, 8 and 9, which are in parallel with the jack socket.



The jack socket on the front and the screw terminal connection for the RS 232 link cannot be used simultaneously.

Note

On the KSD2-GW-MOD.485 gateway, with the RS 485 service interface, only the terminal connection is available.

Connection to the 24 V DC supply and to the RPI internal bus is achieved via the Power Rail.

The cable connections are made via self-opening screw terminals; max. core cross-section 1 x 2.5 mm<sup>2</sup> for rigid cables or 2 x 1.5 mm<sup>2</sup> for flexible cables with plastic wire end ferrules. The screw terminal blocks on the device can be removed for easier connection.

Mount the gateway on the Power Rail and connect the coaxial cable and, if necessary, the RS232/RS485 service interface cable.

The connection diagram for the gateway with RS232 or RS485 interface can be obtained from the current issue of the "Interface DIN-Rail Housing" catalogue.

### Connection type on the front

Connection	KSD2-GW-CN	KSD2-GW-CN.485
A	BNC plug for ControlNet	BNC plug for ControlNet
B	BNC plug for ControlNet	BNC plug for ControlNet
NAP	8-pin RJ-45 connector for configuration tool	8-pin RJ-45 connector for configuration tool

### Terminal assignment

Terminal	KSD2-GW-CN	KSD2-GW-CN.485
22	RxD, RS232 param. interface	RxD/TxD-P, RS485 param. interface
23	TxD, RS232 param. interface	RxD/TxD-N, RS485 param. interface
24	GND, RS232	GND, RS485
43	Screen, RS232	Screen, RS 485
44	Screen, RS232	Screen, RS485
45	Earth	Earth



The number of stations on one RS485 interface (Modbus interface such as RS 485 parameterization interface) is a maximum of 31, as standard.

Note

The maximum length of lead on a bus segment is effectively determined by the following parameters:

- Type of bus cable used
- Transmission rate
- External interference effects
- Number of bus stations

More detailed information on the determination of the maximum lead length can be obtained from the EIA 485 or ISO 8482.

**7.5.3 ControlNet Address**

The address is set by the two rotary switches on the front of the gateway marked "Node Address". Possible addresses are 1 through 99. Using switch X1 the number which has been set is multiplied by 1 and using switch X10 it is multiplied by 10.

**7.5.4 Commissioning**

Before commissioning, check once again that the connections are correct.

Familiarise yourself with the method of communication between the ControlNet scanner (host) and the gateway (ControlNet adapter). Commissioning requires a knowledge of the the ControlNet and the parameterisation of the gateway.

**Time response**

The Remote Process Interface is deterministic. The RPI devices are interrogated cyclically. The most important factors which determine the time response are:

- the higher level host system, e.g. process control system, PLC or PC
- the type and number of ControlNet stations
- the number of the RPI devices and the cycle time of the RPI system

**7.5.5 Operation on the ControlNet**

The I/O data is transmitted via the 'ControlNet scheduled service' (cyclic data exchange). The 'ControlNet unscheduled service' (acyclic data exchange) is used to transmit the commands for the I/O data structure, the redundant mode or the diagnosis and the gateway responses.

**7.5.6 Data Transmission**

The RPI ControlNet gateway can transmit up to 450 data bytes, which consist of 225 input and 225 output bytes. The data in the Input Area is transmitted from the RPI gateway to the host and the data in the Output Area is transmitted to the gateway. Both Input and Output Area, each containing 225 bytes, are divided into two sections: a Control Area (10 bytes) and a Data Area (215 bytes).

	Output Area	Input Area
Word 0 ... Word 9	Output Control Area	Input Control Area
Word 10 ... Word 224	Output Data Area	Input Data Area

Figure 7.8: Output/Input Areas configuration

## Structure of the Output Control Area

Of the ten areas available only the word 0 is used for the command counter.

Word in Output Control Area		Description of the Write Holding Register
0	High	0
	Low	Command Counter Detects commands, which are transmitted by the host to the gateway via the 'unscheduled service'.
1 ... 9		reserved

## Structure of the Output Data Area

The data structure of the Output Area depends on the configuration of the RPI modules. It may contain up to 215 words. The configuration of each RPI device, the data format and the transfer of the status byte can be defined using 'Command Word 2'. Additional information can be obtained from the 'ControlNet Gateway Users Manual'.

## Structure of the Input Control Area

Register	Byte	Description of the Read Holding Register	
0	High	Low	
	Low	Response Counter Echo of the 'Command Counter', if the response to a command for transmission in the gateway is complete.	
1	High	Low	
	Low	Input Update Counter Counts updates of the input data in the input data field.	
2	High	Low	
	Low	RPI Status Counter - a counter for status change of the RPI. A change in the counter indicates either an error status change in ERROR_CODE_LIST or a channel alarm status change in CHANNEL_ALARM_LIST	
3	High	Low	
	Low	RPI Parameter Counter - a counter for each gateway parameter change.	
4	High	Low	
		RPI configuration error Bit 0: RPI configuration error Bit 1: reserved Bit 2: reserved Bit 3: RPI device error Bit 4: RPI channel error Bit 5: Redundant circuit Bit 6: Redundant mode Bit 7: Parameter check	Gateway diagnosis Bit 0: E2PR_Err Bit 1: APPL_Err Bit 2: WATCHDOG Bit 3: TIMEOUT_COM Bit 4: not used Bit 5: not used Bit 6: not used Bit 7: reserved
5...10		reserved	

Date of issue 05/27/03

### Input Data Area

The data structure of the input area depends on the configuration of the RPI modules. It may contain up to 215 words. Further information can be found in the 'ControlNet Gateway Users Manual'.

#### 7.5.7 Command/Response Transmission

The command/response is transferred by means of the 'ControlNet unscheduled service' (acyclic data exchange). The host transmits a command to the gateway and the gateway transmits the response back to the host. The commands available ('Command word') are given in the list below. Further information can be obtained from the User Manual.

- Command Word 2: Set I/O data structure
- Command Word 3: Set redundancy mode
- Command Word 4: Read module diagnosis
- Command Word 5: Single channel function diagnostics
- Command Word 6: Read error code and RPI device alarms
- Command Word 7: Read gateway ID list
- Command Word 8: Read RPI system module types
- Command Word 9: Read error code and channel alarms

#### Format

Command and response are transmitted in the 16-bit integer format. The data length depends on the command and the response. It varies from 'Command Word' to 'Command Word'.

Command Format
Command Word
Data 0
Data 1
Up to data 126

Response Format
Response Word
Data 0
Data 1
Up to data 126

## MONITORING, SIMULATING MEASURED VALUES AND ERROR HANDLING

### 8 RPI in Operation

By monitoring and simulating process data, as explained below, the RPI system and the connected control system can be checked prior to commissioning. While the system is in operation, measured values can be monitored over a lengthy period of time and trend analyses can be made. Just open the respective window on the **PACT<sup>ware</sup>**™ human machine interface by clicking onto the required device with the right mouse button.

#### 8.1 Displaying Measured Values

The Measured Value window shows the current input values, in the binary or analogue format. Binary signals are displayed in the form of LEDs, while analogue input signals are displayed by means of a scaled bar graph. The scaling of the display corresponds to the parameterization of the channel.

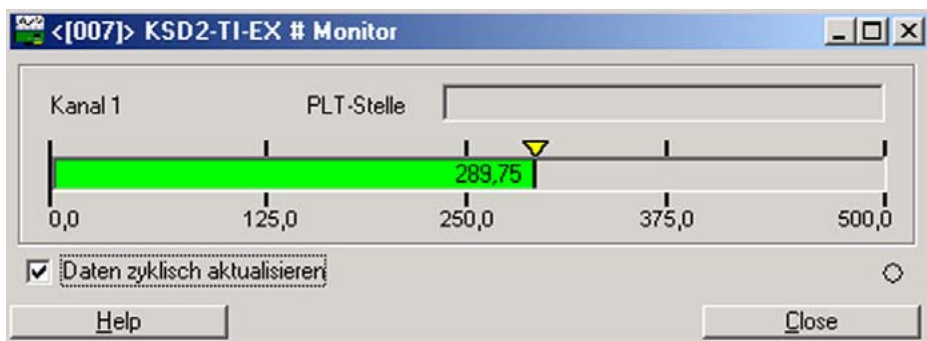

Figure 8.1: Window displaying analogue values



Note

To enable the data of selected devices to be read out and any changes to be indicated, it is necessary to mark the check box `Check connection to RPI device cyclic`.

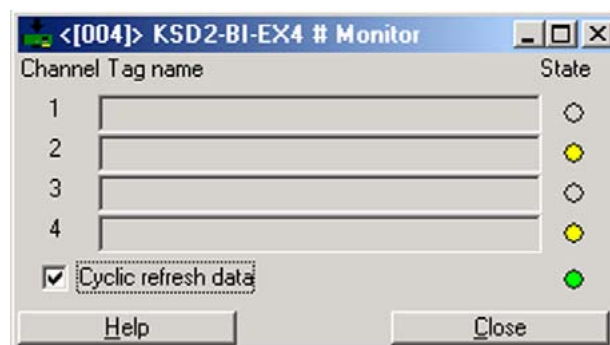

Figure 8.2: Window displaying binary inputs

## 8.2 Displaying Trends

The Trend window contains a recorder which displays the monitored values in a graph. Analogue values are displayed according to the scale (Y axis). The two states of binary information are displayed as 0% value (equals 0), and as 50% value (equals 1).

The <Trend> tab contains the sections *Display* and *Trend*.

On opening the *Trend* menu a recorder appears in the *Trend* section which displays the measured values continuously. The time axis and the axis for the measured value may be adapted to suit the requirements by changing the scale range and the graduation (of the scale). Just move the cursor along the required scale. Hold the right mouse button depressed to scale the axis to the right and upwards, and hold the left button depressed to scale it to the left or downwards. The arrow button down on the right (in the same section) enables you to shift between updating and locking the display.

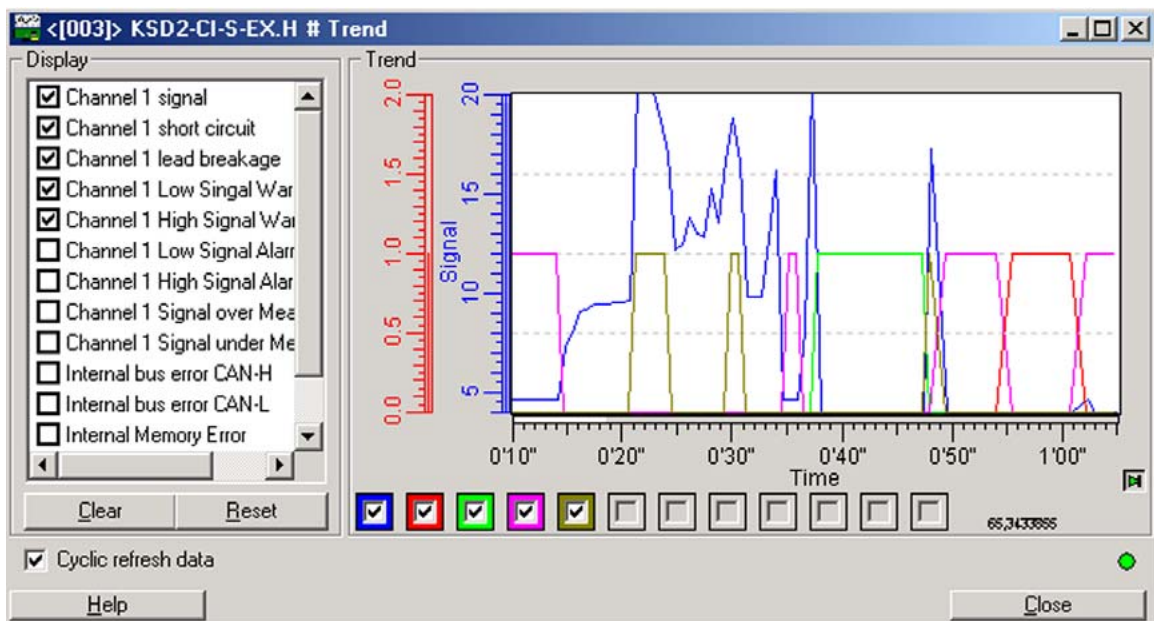

Figure 8.3: Window showing the display and the trend graph

The *Display* section enables you to select the measured values, the messages and limit values, that are to appear in the *Trend* section on the right. To do this, check the box on the left of the value that is to be displayed. Use the *Delete* button to remove selected values and the *Reset* button to undo changes. These options are only available if the 'Cyclic update' checkbox is not marked.

Individual values can be shielded during the recording phase by clicking onto the checkboxes under the recorder and thus removing the check marks. The colours of the boxes correspond to the colours of the recorder graph. The order of the colours from left to right corresponds to the measured values selected in the *Display* section from the top downwards.

### 8.3 Simulation

#### 8.3.1 Simulation of Input Signals

The control system can be checked by simulating the input values without connecting a process peripheral. The actual measured values of the simulated circuit are overwritten by the simulation data if a process peripheral is connected. The data exchange with the other, non-simulated devices, is not interrupted by the simulation.

#### 8.3.2 Simulation of Output Signals

By simulating the output values, the actuators in the field, e.g., valves, pumps, motors, can be checked and adjusted, without a control system connected. The signals of the simulated measuring circuits are input from the human machine interface. Output signals from the control system are suppressed for the simulated measuring circuits. The data exchange with the other, non-simulated devices, is not interrupted by the simulation.



Note

The simulation of a device can be carried out during operation.

During the simulation, the error code 08 ('device being simulated') is displayed on the gateway LC Display and the red LED 'internal bus fault' flashes.

Up to 5 devices can be simulated simultaneously.



Attention

Simulation plays an active part in a process. A simulation of the input values may cause undesirable reactions in the control system.

A simulation of the output values initiates the actuators, opens valves and controls pumps!

A check should be made, in any case, prior to starting the simulation, that no system endangering or undesirable conditions are likely to arise!

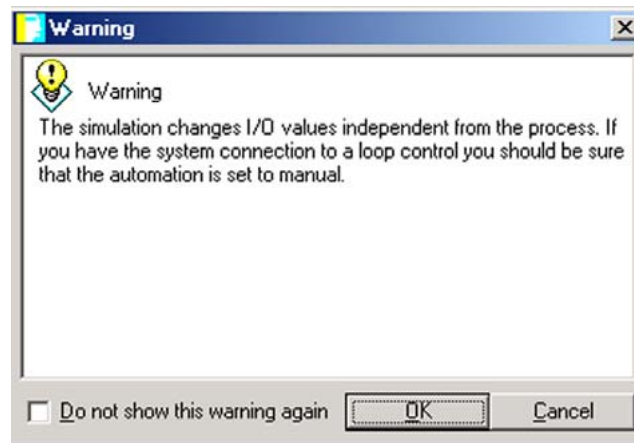

Figure 8.4: Warning prior to starting a simulation



Attention

If you are not authorized or do not wish to intervene in the process, select 'Cancel' to close the window and exit the 'Simulation' menu.

Confirm the warning with **OK** to proceed. If you proceed you are asked to choose the features you want to simulate. There are three simulation options available: Process Value, Device Specific Diagnostic, and Channel Specific Diagnostic.

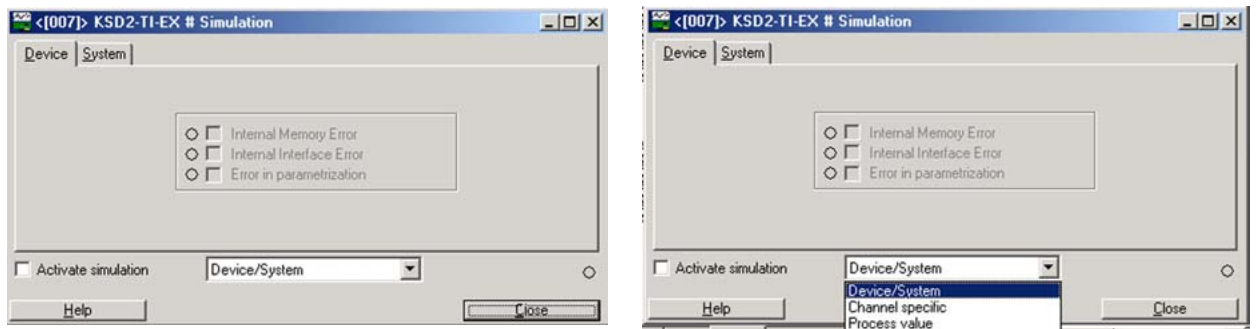

Figure 8.5: Simulation of device and system specific error messages

The options `Device/System` and `Channel specific` enable you to simulate the error messages. Mark the check box of the signal whose status you want to change. A checked box means that the according error signal is set.

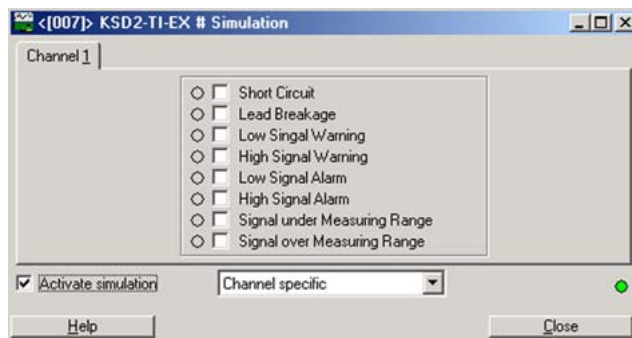

Figure 8.6: Simulation of channel specific messages

If you choose `Process Value` you can simulate the state of the device inputs and outputs. For binary devices you simply check the box beside the LED of the channel whose state you want to change. With analogue devices you will find a text box under the bar graph to enter the desired value.

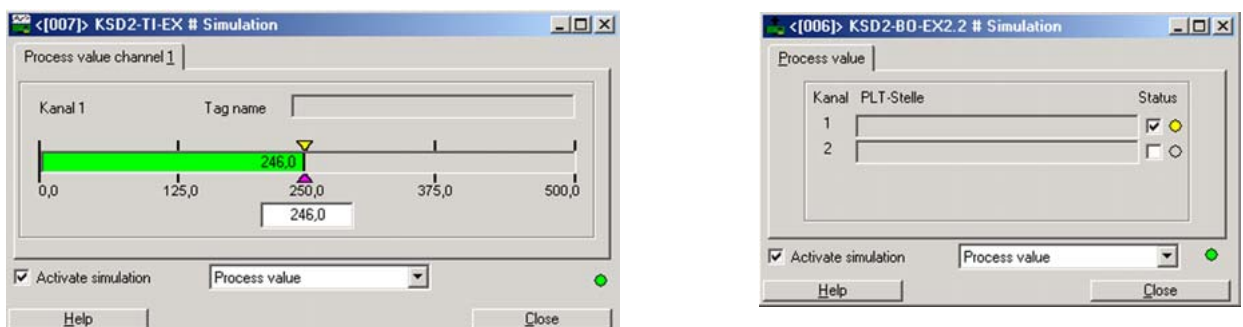

Figure 8.7: Simulation of process values

## 8.4 Servicing and Diagnostic System

The components of the RPI system do not require servicing within the given environmental conditions. Fault conditions on the gateways and devices are indicated by the diagnostics of the RPI human machine interface.

### 8.4.1 Via LEDs, LCD and Pushbuttons on the Devices

The failure of devices is indicated via the LEDs on the devices and the LC display on the gateway, see Kapitel 5 "Configuring and Commissioning the RPI System".

### 8.4.2 Via PC and PACT<sup>ware</sup>™ or RPI Human Machine Interface

If a PC is connected to the RS 232/RS 485 service interface of the gateway, extensive diagnosis can be retrieved via the PACT<sup>ware</sup>™ edition 2 human machine interface. In this event the faulty device is indicated in red on the PC. If the device concerned is marked with the cursor, all the relevant data on the RPI modules can be requested via the "Diagnosis" menu. The same messages are also available on the control system via the external bus.

### 8.4.3 Via a Permanently Installed PC Based Service Level

If gateways are used with the RS 485 service interface, the gateway service interfaces with up to 31 RPI segments can be networked with a common PC. Thus the RPI human machine interface provides the function of a central engineering console for your RPI systems.

### 8.4.4 From the Control System Engineering Console

Depending on the type of implementation in the control system, the RPI can also be controlled from the control system engineering console. Access is obtained for reading and writing to the complete data contents of all the connected gateways and RPI devices: Measured values, status values, configuration data and parameters.

## 8.5 Error Handling

When an error occurs, a message is always generated by the RPI system. If there is not an error on the gateway, or if the system has a redundant gateway, then the unaffected circuits continue to operate, uninterrupted. So far as is possible, the faulty devices output replacement values to the control system and in the field.

### 8.5.1 Error Detection within the RPI System

The RPI system offers a number of methods of error detection and device diagnosis. There are four main procedures:

- Error detection using the LEDs on the devices
- Error detection using the LC display on the gateway
- Error detection and device diagnosis using the PACT<sup>ware</sup>™ human machine interface
- Error detection and device diagnosis via the external bus

#### 8.5.1.1 Error Detection Using the LEDs on the Devices:

The LEDs on the front panels of the gateways and the RPI devices provide information on:

- Voltage supply
- Lead breakage or short circuit of the field circuits
- Device errors
- Status of the internal communication via the bus
- Status of the external communication via the external bus system



Note

Detailed information on the possible status of the LEDs on the front panels of the devices is provided in the appendix section 11 "RPI System Error Messages":

#### 8.5.1.2 Error Detection Using the LC Display on the Gateway

An error code is displayed on the LC display on the gateway, which can be used to diagnose the error. A list of the error codes is given in Chapter in the appendix Kapitel 11 "RPI System Error Messages".

### 8.5.1.3 Error Detection Using the PACT<sub>ware</sub><sup>TM</sup> Human Machine Interface

Detailed information on the status of the RPI system can be obtained from the PACT<sub>ware</sub><sup>TM</sup> human machine interface. Errors are indicated by coloured identification of the devices involved in the main menu.. The error can be precisely pinpointed using the diagnostic menu.



Detailed information on error detection and diagnosis with the PACT<sub>ware</sub><sup>TM</sup> edition 2 human machine interface are given in Part PACT<sub>ware</sub><sup>TM</sup>.

### 8.5.2 Error detection from the control system engineering console

Depending on the type of implementation in the control system, it is also possible to detect errors in the RPI system from the control system engineering console. If all diagnostic functions are implemented, access to the complete data for the connected gateways and RPI devices will be available as when detecting errors using the RPI human machine interface: Measured values, status values, configuration data and parameters.

### 8.5.3 Fault elimination within the RPI System

The fault diagnosis shows whether the error lies in the field circuit, in the internal or external bus system, in the parameterization, or in the device itself. If the fault lies in the device, then it can be replaced by a new one.

#### 8.5.3.1 Replacement in the case of failure of an individual device

The device is replaced by another of similar type, which is set to the neutral address 0. Communication with the gateway commences immediately. The gateway overwrites the address 0 with that of the replacement module. The parameter set is transferred to the device following storage in the gateway. Normal operation is resumed. A status message regarding the elimination of the fault is transmitted via the external bus.



The failure of one or more devices has no effect on the function of the remaining serviceable devices.

Note

Devices intended for replacement purposes should be set to the neutral address 0. Otherwise, on the replacement of an individual device, the automatic address assignment cannot take place.

In the event that the new device has an address other than „0“, an error message is generated. If the address of the new device is identical to that of another device, then its function is terminated and a second error message ensues. In this case the correct address should be immediately allocated to the new device, as described in Chapter 7.

#### 8.5.3.2 Replacement in the event of the simultaneous failure of a number of devices

If the failed devices are all of different types, they are simply replaced as described under “Replacement in the case of failure of a single device.”The replacement devices are identified by the gateway.The correct addresses for the internal bus are assigned automatically. The parameters are loaded into the devices. The system informs the control system that full serviceability has been regained, in that the existing error messages are withdrawn.

If more than one device of a type has failed, the defective devices are removed from the rail.The replacement devices are set to the address “0” at the factory.They are snapped onto the rail one after the other, in ascending order of address for the internal bus.The gateway automatically assigns the lowest address of all the failed devices on the internal bus to each new device. Then the parameters are automatically loaded into the new device. The next replacement device can then be snapped onto the rail.



When using this method, no addresses, parameters or measurement ranges must be set when servicing. Straightforward replacement of the devices is sufficient.

Note

If more than one device of a type has failed and it is desired that the ascending sequence of addresses is not maintained, then the device addresses and parameter sets are loaded into the devices individually in a separate work area, using a gateway, via a PC and the **PACT<sub>ware</sub>**<sup>TM</sup> human machine interface. These new devices are then incorporated into the system by snapping them onto the rail.



Note

The devices must be allocated addresses in ascending order, commencing with the lowest address in the series.  
Otherwise the automatic loading of the parameter sets does not function.

### 8.6 Error detection on the external bus system

Depending on the bus system used, the scope of error detection and device diagnosis are also very extensive. The way in which the error and diagnostic information are placed at the disposal of the user depends very much, however, on the master device used.

Reference should be made to the documentation for the bus system in use, as provided by the manufacturer.



Note

Detailed information for an evaluation of PROFIBUS-DP, PROFIBUS DP V1, MODBUS RTU, MODBUS PLUS oder CONTROLNET can be found in **Chapter 7 "Gateways"**.

### 8.7 Fault elimination on the external bus system

The possibilities of eliminating a bus error depend on the higher level system which is installed. In the case of a redundant mode of operation, gateway No.2 automatically takes over the functions of gateway No.1, if it has detected an error on the external bus.

The failure of bus 1 is detected by the bus master. In parallel with this, gateway No. 2 provides a message via bus 2.

### 8.8 Replacement of Defective Gateways

#### Replacing a gateway:

The addresses and parameters for the new gateway should be downloaded via PC and **PACT<sub>ware</sub>**<sup>TM</sup>. Normal operation is resumed. A status message regarding the elimination of the fault is transmitted via the external bus.

#### Replacing a gateway - external bus redundant:

If the system is redundant, due to the use of 2 gateways and two external bus branches, one gateway is defined as active (priority) and the other as redundant.

If one external bus branch or one gateway fails, then communication takes place via the second gateway and the second bus branch. A status message regarding the fault is transmitted via the bus branch that remains operative.

The addresses and parameters for a new gateway are set by means of a PC and the **PACT<sub>ware</sub>**<sup>TM</sup> human machine interface.

## 9 Dismantling and Disposal

### Repackaging

Where devices and components are to be stored for reuse at a future date, they should be protected against shock loads and humidity. The original packaging affords optimum protection.

### Disposal



Note

Electronic scrap is special refuse. Local regulations must be followed when disposing of electronic components.

The devices in the RPI system do not contain internal batteries which must be removed prior to disposal.

---

## APPENDIX

---

### 10 Quick instructions

#### 10.1 Installation of the Software on your PC

It is recommended that all Windows programs are closed prior to the installation.

Load the PACT<sub>ware</sub><sup>TM</sup> CD into your CD drive. Start Setup.exe on the installation disc by going to the Start menu and clicking on Run. Enter the following line into the next window.

Drive letter:\setup.exe (e.g. e:\setup.exe).

You can also select your disc drive by clicking Browse and then Setup.exe.

Click OK to confirm your entry. Now the setup program starts.

The human machine interface is provided with a context sensitive help menu to answer your questions.

#### 10.2 Voltage supply for the RPI system

The supply voltage (20 to 30 V DC or 230V AC) is connected to the power feed modules that make a connection to the Power Rail. The devices will be plugged onto the rail later, when they will have been configured and the parameters will have been set.

Power will now be supplied automatically and the green 'PWR' LED's on the devices will light.

#### 10.3 Configuration and Parameter Assignment of the RPI System

The two alternative methods of configuring the RPI system are described in the following:

##### 10.3.1 Offline Configuration and Downloading to the Devices

The project is set up offline, using the PACT<sub>ware</sub><sup>TM</sup> and stored in the PC. On Download, the data in all configuration files relating to the project, are stored in the individual devices.

1. Start PACT<sub>ware</sub><sup>TM</sup> edition 2:

Start the PACT<sub>ware</sub><sup>TM</sup> human machine interface on your PC. When working with PACT<sub>ware</sub><sup>TM</sup> you can change decisions you have made later on.

After the program start, the main window opens. The project window displays and installs the RPI system and the various components and drivers. The edit window displays the various menus that are required for the project such as device catalogue, register cards for the parameter assignment, menus for diagnosis, measurement values and simulation or the communication monitor.

2. New project:

A new project can be configured immediately after the program start. By adding the COM driver, the gateways, and the various devices the RPI system is installed in the project window.

There are three different ways to add the components

- Click onto HOST IBM-PC, COM Driver or Gateway with the right mouse button and select <Add device>. A menu opens in the edit window which only offers options that can be projected at this point.
- Click HOST IBM-PC, COM Driver or Gateway with the right mouse button and then click the <Paste> button down on the left. The menu described above opens.
- On the menu bar click Project and then Device catalogue or simply press the function key F3. The device catalogue which contains all the installed device and communication drivers now appears in the edit window.

All the installed components appear in the middle column. Click onto the plus sign to the left of the components to be projected.

The COM driver, Gateway and Device subdirectories are then displayed.

Now the individual components should be projected in order, as follows:

- COM driver ( RPI serial interface, HART protocol driver)
- Gateway or the devices for direct communication with the HART driver
- Second gateway for redundant communication with the control system or the first RPI device.
- RPI devices

3. Open project:

Select <File> <Open>. Now you can open project \*.PW and start editing it.

4. Select COM driver:

Highlight <HOST IBM-PC>, select the COM driver, the RPI serial interface or the HART protocol driver from the menu or from the device catalogue and paste it to the project window.

In order to project the COM driver you can

- click on the COM driver in the right window, and drag it, keeping the mouse button depressed, to HOST IBM\_PC in the left window (drag and drop) or
- double click the COM driver in the right window or
- click on the COM driver once and confirm the selection by clicking the Paste button down on the right.



Note

Note that the level in the left column where you can project the required component should be activated, i.e. be on a grey or blue background.

This means that, if you wish to project a COM driver, the HOST IBM PC must be activated, for K or E devices the KE-GUT driver must be activated, and for an RPI device the RPI gateway should be activated.

If this is not the case, an error message will appear.

5. Select gateway:

Mark the COM driver, select the gateway in the menu or in the device catalogue and paste it to the project window. The gateway automatically obtains the address [001] while the redundant gateway obtains the address [002] as RPI internal bus addresses.

6. Select devices:

Open the menu or the device catalogue and mark the required device (its symbol is on a blue background) and accept it with <Paste> or <OK> (the device is then inserted under the position marked on the left hand side) or just drag the marked device to the project window. On pasting a device to the project window PACT<sup>ware</sup>™ automatically assigns the lowest address available to the RPI internal CAN-Bus. The 3-digit number appears in square brackets to the left of the device. A maximum of 125 addresses, [003] to [127], can be assigned per gateway for the internal bus. We recommend that addresses should be assigned consecutively for similar device functions. The sequence in which you arrange the devices is arbitrary. The assignment to the hardware takes place during the addressing procedure.

### 7. Configuring and parameterizing

In order to edit a PACT<sub>ware</sub><sup>TM</sup> component

- click onto the component that you wish to edit in the project window with the right mouse button and select Edit, or
- double click the component that you wish to edit in the project window, or
- click onto the component that you wish to edit in the project window with the left mouse button and then click the Edit button down on the right in the project window, or
- click onto the component that you wish to edit in the project window with the left mouse button and then depress the function key F5.

Now the display and interface of the Device Type Manager opens, providing the Device Info, Description and Parameter tabs for offline parameterization.

The Device Info tab provides unchangeable information on the selected component.

The Description tab can be used to store data which is specific to a measuring point (e.g. tag name and measuring point description). This information is only stored in the project not in the devices.

The Parameter tab provides access to all settable parameter values of the selected components. Information which is not changeable is displayed in light grey on this tab.

The data on this tab can be

- stored in a file
- stored in the device.

When you click the Save to device button, PACT<sub>ware</sub><sup>TM</sup> edition 2 establishes a connection to the selected device and loads the data to this device.



Note

The Save to file or Save to device function stores the data of the activated device or the COM driver exclusively. The remaining project data is not stored.

This means that in a project consisting of a COM driver and devices the changed settings must be downloaded twice - for the COM driver and for the device separately.

### 8. Parameterizing the COM port

In order to parameterize the COM port, the COM port on the PC/notebook and the baud rate of the serial interface should be set in the tab.

### 9. Parameterizing gateways

In order to parameterize the gateways, the address of the gateways, the baud rate, and the parity/stop bit should be entered. You enter the data into the white fields of the dialogue window tabs.

Two code words can be used to provide protected access. Each of these ensures full access to the system. Always assign both code words. If one code word is left blank, it increases the risk of access by unauthorised persons.

If you click on '**Panel locked**', you will not be able to make changes later with the gateway buttons. Therefore this option should not be marked in the check box at this stage.

In order to be able to link the parameterization interfaces together, assign an address.

This address must be assigned, even in the case of simple point-to-point RS 232 connections.

In the diagram, it appears in pointed brackets '<0>'. The selected address must correspond with that set later on the gateway.

When this window is closed, the gateway data should be stored in a file (offline) or in the device (online) as when parameterising the COM ports. Any names can be used for the files, but the file extension is always '.dat'.

### 10. Parameterizing RPI devices

Depending on the device type, different tabs are opened in order to be able to parameterize the devices. Detailed information is given in appendix B about PACT<sub>ware</sub><sup>TM</sup>.

11. Store the project:  
Save the data for your RPI system on your PC by selecting 'Project ? Save as'.  
You can select any name for your project, but the file extension is always '\*.PW'.
12. The configuration of the RPI system is now complete.  
You will next install the gateway and download the configuration into the hardware.
13. Installation of the gateway:  
Snap the gateway onto the mounting rail containing the Power Rail. The green '**PWR**' LED indicates that the power supply is present. The '**COM**' (Communication), '**EXT**' (External) and '**INT**' (Internal) gateway LEDs flash. The gateway version number appears briefly on the display, followed by '**SYN**' (Synchronisation).
14. Cable connection:  
Now connect the gateway parameterizing interface with your PC interface, using the cable supplied. If you are using a gateway with an RS232 parameterising interface, connect your PC either to the jack on the front, or to the plug-in screw terminals 7, 8 and 9 of the gateway.  
  
The front jack and the screw terminals for the RS232 must not be used at the same time.  
  
The gateway with the RS485 parameterization interface has only the plug-in screw terminal connection.
15. Gateway settings, address and baud rate of the parameterizing interface:  
To set the address and baud rate of the interface, press the gateway 'Mode' button repeatedly, until 'E' appears in the right hand space on the gateway display. The number on the left is the address of the parameterizing interface. If this does not agree with the entry in the pointed brackets '<0>' on the human machine interface, select the correct address by operating the  or  pushbuttons on the gateway. Now depress the '**Mode**' button until the gateway display flashes. The address has now been accepted by the gateway.  
  
Now press the gateway '**Mode**' button until '**G**' appears in the right hand position on the gateway display. The number on the left is a code denoting the parameterizing interface baud rate. If this does not agree with the data rate assigned to the COM port by the human machine interface, select the correct setting by operating the  or  buttons on the gateway. Finally, depress the '**Mode**' button until the gateway display flashes. The baud rate has now been accepted by the gateway.  
  
Baud rate code digits:
 

'1'	1.2 kbit/s
'2'	2.4 kbit/s
'4'	4.8 kbit/s
'9'	9.6 kbit/s
'19'	19.2 kbit/s
'28'	28.8 kbit/s
16. Download:  
On the human machine interface of your PC, click on the gateway and store your configuration in the gateway, using 'Project? Download'.

### 17. Installing the devices::

Your devices are factory-set to the address '0' for the internal bus. The device that is to have the lowest address should now be snapped onto the Power Rail, so that the following automatic sequence can take place, followed one after the other by the remaining devices, in the sequence planned in the project tree. The gateway automatically assigns the lowest planned address that has yet to be assigned, to the device with the address '0'.

It then automatically writes the set configuration into the device. The 'ERR' and 'PWR' LEDs on the device concerned flash briefly, then 'ERR' goes out. When the 'PWR' LED lights continuously, configuration of that device is complete and the next device can be snapped on.

### 18. Address '0':

If you wish to use devices which are neither set to the address '0' nor to the planned project address, then you can assign the address '0' yourself, as described in the appendix.

### 19. Incorrect connections:

See Section 10.4 "Error Messages".

## 10.3.2 Manual Address Assignment for the Devices and Subsequent Online Configuration and Parameter Assignment Using PACT<sup>ware</sup>™ Edition 2

The device addresses are set manually. Then the devices are configured and parameterized, during operation, using the RPI human machine interface.

This method is advantageous,



- if the system is to be set into operation first in the workshop outside the plant,
- if the device data changes frequently during commissioning,
- if the devices are already pre-configured.



#### 1. Preparation::

You have set up the power supply for the RPI system. Snap the gateway onto the mounting rail with the Power Rail. The green 'PWR' LED will light, indicating that the power supply is present. The 'COM' (Communication), 'EXT' (External) and 'INT' (Internal) LEDs of the gateway will flash. The gateway version number will appear briefly on the display, followed by 'SYN' (Synchronisation).

#### 2. Address assignment:

You now assign the device addresses manually. The sequence of devices and addresses is arbitrary.

Now press the 'Mode' button of the gateway repeatedly, until 'b' appears on the right hand position on the gateway display. This is the symbol denoting the 'address assignment' mode of operation. The number on the left of the symbol represents a device address. Using the  or  buttons on the gateway select the desired address, in the range 3 to 127 (the address '0' is reserved for new or replacement devices, '1' is reserved for the gateway, '2' for the redundant gateway). The only addresses displayed are those not already assigned within the system. An address is accepted by depressing the 'ADR' button on the device for a longer period. The green 'PWR' LED on the device flashes for a brief period. Brief flashing of the red 'COM' LED is irrelevant, as is the error message on the gateway display, which indicates that the device is addressed, but has not yet been accepted into the gateway configuration.

Now mount the next device, select the appropriate address on the gateway, using the  or  buttons, etc. Repeat this procedure until all the devices have been installed and assigned addresses. It is important, that the devices are mounted and addressed one after the other, otherwise the gateway cannot build up the connection to each device.

As soon as a device is snapped on, the red 'COM' LED on the gateway goes out, if not, depress the 'Mode' button for 3 - 5 secs, in Mode 'F'. The green 'PWR' LED on the device illuminates and the red 'ERR' (Error) LED flashes.

#### 3. Conflicting addresses and address '0':

It is possible to mount a device 'B', that already has another address, provided that a different device 'A' is not in operation on the gateway with the same address. If it is, device 'A' has to be removed from the mounting rail and device 'B' assigned the correct address, following the procedure given above. Device 'A' can then be returned to operation by simply snapping it onto the rail again.

1. In order to avoid such conflicts, new devices are factory-set to the address '0'. As described in Section 10.7 "Setting Address '0' / Deleting Address on a Device" you can also assign the address '0' yourself.
2. To check the addresses of devices:

You can check the addresses of devices. Press the '**Mode**' button repeatedly, until '**C**' (Check internal address) appears in the right hand position on the gateway display. The number to the left of the symbol represents a device address. Using the  or  buttons on the gateway, select the desired address. Only those addresses are displayed which have actually been assigned within the system. The green '**PWR**' LED flashes on the device to which the selected address belongs.

Conversely, you can determine the address of a particular device, in operating mode '**C**' of the gateway. Press the '**ADR**' button briefly on the device. The green '**PWR**' LED flashes on the device; the address of the device appears on the gateway display.

3. To teach the bus structure into the gateway::

Press the gateway '**Mode**' button repeatedly, until '**A**' appears in the right hand position on the gateway display (normal operation). In mode '**A**' press the '**Mode**' button once again and hold it depressed until the LC display flashes. Brief flashing of the LEDs is irrelevant. The gateway has now accepted the existing bus structure.

4. To set the address and the baud rate of the gateway parameterizing interface:

In order to be able to link the parameterization interfaces together, assign an address.

This address must be assigned, even in the case of simple point-to-point RS 232 connections.

Press the gateway '**Mode**' button repeatedly, until '**E**' appears in the right hand position on the gateway display. The number on the left is the address of the parameterizing interface. Select the desired address using the  or  buttons on the gateway. The address is accepted in the gateway by depressing the '**Mode**' button for a longer period. Later on, this address must agree with the entry in the pointed brackets '<0>' on the human machine interface.

Now press the gateway '**Mode**' button repeatedly, until '**G**' (baud rate setting) appears in the right hand position on the gateway display. The adjacent number on the left is the code for the parameterizing interface baud rate: Select the desired code using the  or  buttons on the gateway. The baud rate is accepted in the gateway by depressing the '**Mode**' button, until the LC display flashes. Later on, this baud rate must agree with the COM port setting of the RPI human machine interface.

Baud rate codes:

'1'	1.2 kbit/s
'2'	2.4 kbit/s
'4'	4.8 kbit/s
'9'	9.6 kbit/s
'19'	19.2 kbit/s
'28'	28.8 kbit/s

5. To set the gateway address for the external bus (Mode D):

Now press the gateway '**Mode**' button repeatedly, until '**d**' (external address setting) appears in the right hand position on the gateway display. The adjacent number on the left is the code for the gateway baudrate for the external bus: Select the desired value using the  or  buttons on the gateway. The baud rate is accepted in the gateway by depressing the '**Mode**' button for a longer period.

6. The addressing and the settings on the devices are now complete:

You should now connect your PC and establish the device parameters, using the RPI human machine interface.

7. Now connect the gateway parameterizing interface with your PC interface, using the cable supplied.

If you are using a gateway with an RS232 parameterizing interface, connect your PC either to the jack on the front, or to the plug-in screw terminals 7, 8 and 9 of the gateway.

The front jack and the screw terminals for the RS 232 connection must not be used at the same time.

The gateway with the RS485 parameterization interface has only the plug-in screw terminal connection.

### 8. Start PACT<sub>ware</sub><sup>TM</sup>:

You start the PACT<sub>ware</sub><sup>TM</sup> human machine interface on your PC. Your PC, its COM port interface, your gateway and, depending on the circumstances, other devices, are symbolically represented in the left window of the main menu. If this is not the case, then click on Button '2' in the window.

### 9. Parameterizing the COM Port

Parameterize the COM port by setting the COM port on the PC/notebook and the baud rate of the serial interface in the dialogue window tab.

### 10. Parameterizing gateways

Parameterize the gateways by entering the gateway address, the baud rate, and the parity/stop bit. You enter the data into the white fields of the dialogue window tabs.

Two code words can be used to provide protected access. Each of these ensures full access to the system. Always assign both code words. If one code word is left blank, it increases the risk of access by unauthorised persons.

If you click on '**Panel locked**', you will not be able to make changes later with the gateway buttons. Therefore this item should not be selected at this stage.

In order to be able to link the parameterization interfaces together, assign an address.

This address must be assigned, even in the case of simple point-to-point RS 232 connections.

In the diagram, it appears in pointed brackets '<0>'. The selected address must correspond with that set later on the gateway.

When closing the window save the data of the gateways to a file (offline) or to a device (online) as in the case of the COM port parameterization. Any names can be used for the files, but the file extension is always '.dat'.

### 11. To set the address of the parameterizing interface for the gateway:

The address for the parameterizing interface '<0>' is given in the pointed brackets in the left window of the main menu, adjacent to the symbol for the gateway. This must agree with the setting on the gateway in mode 'E'.

If this is not the case, select 'Device data ? RPI settings' or 'Device data ? Edit device data' (depending on the version). Set the correct address for the parameterizing interface in the '**Communication**' tab.

### 12. To set up the gateway connection:

Click on the gateway symbol in the left window of the main menu and select 'Connection ? Establish connection'. The symbols for the devices appear in bold text.

When you are asked whether you want to copy the set gateway configuration into the project, you must respond with '**Yes**' in order that the configuration data from the devices and the gateway will be accepted into your PC.

If you respond with '**No**' all the devices will be assigned the default values.

Do not accept the device data entries into the new project.

You can always change these values at any later point in time.

Depending on the version of your human machine interface the question appears if the device data files should be accepted. You respond '**Yes for all**'.

The connection has now been successfully established.

### 13. Faulty connection::

see Appendix, Error Messages.

14. Parameterizing devices::

Now set up the data for the individual devices. In the left window of the main menu of the human machine interface, click on a device that is to be configured and select 'Device data ? Edit device data'. A dialogue window opens, with tabs having white fields into which the data can be entered. Write the data into the device with 'Device ? Save to device'. On closing the device data window, save the data in a file. The file name can be freely selected, but the file name extension must always be **\*.dat**.

Depending on the device type used, different tabs are opened for parameterizing the devices. Detailed information is given in appendix B about PACT<sup>ware</sup><sup>TM</sup>.

15. Store the project:

Save the data for your RPI system on your PC using 'Project ?Project save as'.

The file name for your project can be freely selected, but the file extension is always **'PW'**.

**10.4 Error Messages**

1. RPI human machine interface error messages::

The COM port you wish to use to establish a connection, is either not available, or is already being used for another purpose:

Adapt the COM port settings for your project on the human machine interface to the COM port settings on your PC.

It has not been possible to establish a connection with the device:



If a connection has not been established, you should check the cable connection with the gateway parameterizing interface; the COM ports, COM 1 to COM 4, selected for adaptation to your PC, using the RPI human machine interface; the compatibility of the baud rate of the parameterizing interface on the gateway in mode **'G'** with the setting of the COM port on the human machine interface and the agreement between the address of the parameterizing interface on the gateway in mode **'E'** and that on the human machine interface **'<0>'**.

2. Error messages on the gateway LC display:

Now press the **'Mode'** button on the priority gateway repeatedly, until **'A'** (normal operation) appears in the right hand position on the gateway display.

If the left hand positions on the display are empty, the system is in normal operation.

If a fault occurs, the address of the faulty device appears on the left hand side, adjacent to the **'A'** symbol. The display then cycles between **'E'** (Error) and an error code that indicates the type of fault that has occurred.

Operate the  or  buttons a number of times, in order to establish whether any other devices have a fault condition.

**Error codes:**

01	There is a device in the gateway configuration that is not available on the internal bus.
02	A device is present on the internal bus, that is not in the gateway configuration.
03	Incorrect type of device.
04	Device error.
05	Channel error, e.g. lead breakage or short-circuit. For the channel number, see the flashing red <b>'IN/CHK'</b> or <b>'OUT/CHK'</b> LED on the indicated device.
06	The device is in the initialisation phase.
07	Address conflict.
08	The device is in the simulation mode.
81	Loss of redundancy - internal communication.
82	Loss of redundancy - external communication.
83	Loss of redundancy - user initiated.
84	The check sums of the parameter sets in the active and passive gateways are not the same.

### 10.5 To Replace a Device while the System is in Operation

If a device is to be replaced, the system must first have been set into operation from the gateway. It is important, that the device data are stored in the gateway, i.e. using '**Save to device**' or '**Download**', otherwise the new device will have nonsensical data written to it.

Devices of the same type can be exchanged while the system is in operation, providing they have the address '**0**' (new device). The new device is then automatically assigned the address and related data of the old device!

If more than one device of the same type are exchanged, then you must install the replacement device that is to receive the lowest address first, since the gateway stores addresses in the devices in order of ascending addresses.

The address of previously used, serviceable devices, which are to be stored, should be set to '**0**' so that later they can be incorporated into a new system without problem.

### 10.6 Replacing a Gateway

Replace the gateway and set the correct address (Mode '**E**') and baud rate (Mode '**G**') on the new gateway, as described above for the parameterizing interface. Connect your PC to the parameterizing interface, using the cable. Start the RPI human machine interface on your PC, load your project and store the data in the new gateway, using '**Download**'.

Of course, you can also pre-configure the new gateway in this way, in the workshop, and use it later in the system, without further processing.

### 10.7 Setting Address '0' / Deleting Address on a Device

When supplied, the devices have the address '**0**'. This address can be automatically overwritten and replaced with the planned project address by the gateway, thus considerably simplifying the commissioning and replacement of the devices. You can give the address '**0**' to a device that has another address. Snap the device onto a mounting rail containing a Power Rail and having a power supply, but without a gateway. Press the '**ADR**' button on the device, until the green '**PWR**' LED flashes.

### 10.8 Deleting an Existing Gateway Configuration (from Version 1.4)

From gateway version 1.4, onwards, it is possible to delete an existing gateway configuration. Snap the gateway onto a mounting rail containing a Power Rail and having a power supply, but without any other devices mounted. The LC display shows '**SYN**'. Now press the '**Mode**' button for longer than 3 s. The '**INT**' LED goes out. The set configuration and all other device data stored in the gateway, are deleted.

### 10.9 Redundant Power Supply

The 24 V DC power supply can be laid out as a redundant system. Both power supplies can be fed together via a single power supply module, or via two separate power supply modules, on the Power Rail. Special power supply modules are available, having decoupling diodes, which avoid interference between the two power supply nets (see Interface DIN-Rail Housing catalogue).

### 10.10 Redundant Internal Bus System

The internal bus system always has a redundant layout. The failure of the bus system and switch-over to operation via the redundant system is automatically signalled to the control system.

### 10.11 Redundant External Bus System

The external bus system can also be provided with a redundant layout by installing a second gateway. In this case, the configuration data is replicated in the second gateway.

## 10.12 Construction of a Redundant External Bus System with Gateways

### 1. Project with redundant gateway:

Build-up your project in the usual way, with a gateway, using the PACT<sub>ware</sub><sup>TM</sup> human machine interface. In the project window, highlight HOST-IBM PC (its symbol is on a blue background). Now highlight your gateway in the list of devices and select '**Paste**'.



In the project window, highlight the redundant gateway (its symbol is on a blue background). Highlight your redundant gateway in the list of devices and select '**Paste**'.

Go back to the project window and highlight the redundant gateway (its symbol is on a blue background). Now add all the required RPI devices until the project tree is complete.

On adding a device, PACT<sub>ware</sub><sup>TM</sup> automatically assigns an address for the RPI internal CAN bus. This appears on the left of the component as a symbol in pointed brackets or '<1>'. The software assigns different addresses to priority and non-priority devices and it always assigns the lowest free address, <3> to <127>, to devices that are inserted.

### 2. Address assignment and prioritization:

When operating with redundant gateways, the gateway having the address '1' is the priority gateway; that with the address '2' is the non-priority gateway. During fault-free operation, both gateways transfer the data from the field to the control system, via the external bus. In order to avoid conflicts, data from the control system is passed to the field exclusively via the priority gateway. It is only when this path is interrupted, that data is passed to the field via the non-priority gateway.

Now press the '**Mode**' button on the non-priority gateway repeatedly, until '**b**' (address assignment) appears in the right hand position on the gateway display. Using the  or  buttons set the address '2' on the left hand side of the display. Press the '**Mode**' button for longer than 3 s. The address is accepted into the gateway.

Address '1' is automatically assigned to the priority gateway.

### 3. Editing RPI components

Mark the devices in the project window in order and open the tabs for editing these devices. When parameterizing the two gateways it should be noted that the addresses for the higher-level control system must differ. Similarly, if a serial RS485 interface is used for the parameterization, the two gateways must be assigned two different addresses.

### 4. Address and baud rate setting on the gateway parameterizing interface::

As described above, using the pushbuttons, set the addresses (Mode '**E**') and the baud rates (Mode '**G**') for the parameterizing interfaces on both gateways. Take care that the addresses are different; if the RS 485 parameterizing interfaces are linked together.

### 5. Commissioning:

Mount both gateways and set the RPI system into operation as usual, with the priority gateway. Connect the system to your PC and save your configuration data in this gateway via '**Download**'.

Now install the non-priority gateway, connect it to your PC and then save your configuration data in this gateway via '**Download**'.

If the '**E81**' error message now appears on the gateway displays, then the priority gateway has not yet been detected. This error is eliminated by briefly interrupting the power supply.

## 11 RPI System Error Messages

### 11.1 Error Messages on the Display of the KSD2-GW-. Gateway

Error Code	Meaning
01	A device included in the gateway configuration does not exist as a station on the internal bus
02	Device address indicates it is not included in the gateway configuration.
03	Incorrect device type
04	Device error
05	Channel error, e.g. lead breakage or short circuit of the signal circuit of the faulty device (channel No. see device LED)
06	Device in initialisation phase
07	Addressing conflict
08	Device is being simulated
81	Redundant communication failure internal communication
82	Redundant communication failure external communication
83	Redundant communication failure user initiated
84	Check sums of the parameter sets in the active and passive gateway are not the same

### 11.2 Error Messages on the Display of the KSD2-GW2-... Gateway

Data Structure	Error	Indication	Comment
-	Err 01	Dev miss	Device not available
-	Err 02	Dev not conf	Device not configured
-	Err 03	Wrg Dev	Wrong device
-	Err 04	Dev Err	Device causes error
-	Err 05	Chn Err	Channel causes error
-	Err 06	Lin Err	Error in linearization table
-	Err 07	Addr Confl	Two devices with same address
-	Err 08	Sim	Device in simulation mode
Divice Diag.	E2PR_ERR	MEM	Memory error
	APPL_ERR	INT	Internal interface
	CAN_H_FAULT	CAN_H	CAN Bus connection: short-circuit
	CAN_L_FAULT	CAN_L	CAN Bus connection: lead breakage
	All other	NOT DEF	Not defined or supported
Func Diag.	SHORT_CIRC	SC	-
	LEAD-BREAK	LB	-
	LO-ALM	LO_WRN	Low signal: Warning
	HI_ALM	HI_WRN	High signal: Warning
	LO_LO_ALM	LO_ALM	Low signal: Alarm
	HI_HI_ALM	HI_ALM	High signal: Alarm
	UNDER_RANGE	UR	-
	OVER_RANGE	OR	-
	All other	NOT_DEF	Not defined or supported

Date of issue 05/27/03

11.3 Error Messages on the Gateways via LED

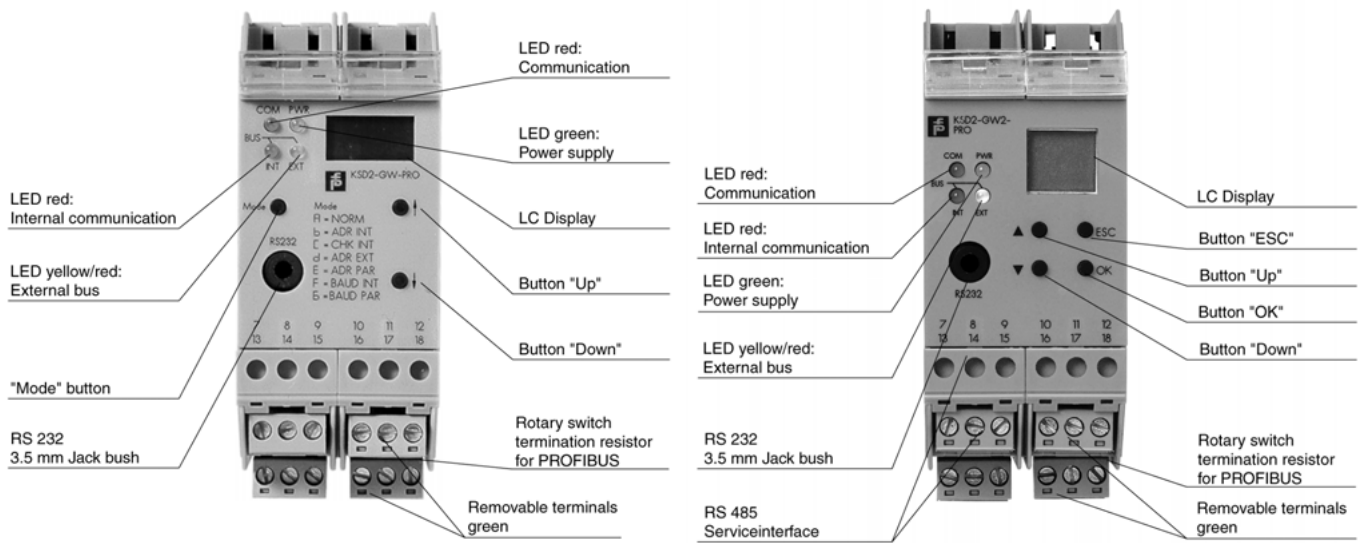
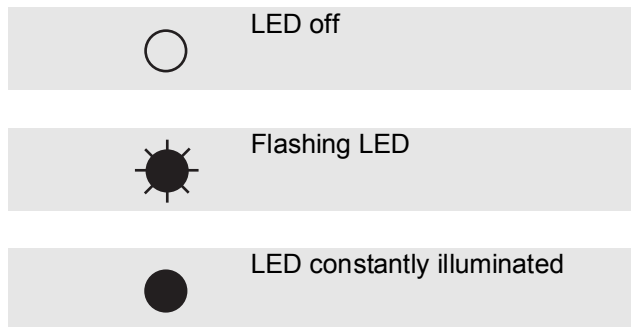
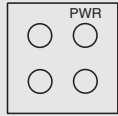

Figure 11.1: Front View of the KSD2-GW-... and KSD2-GW2-... gateways

The following symbols are used:



## LED PWR (green)



No voltage supply

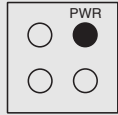

Voltage supply present

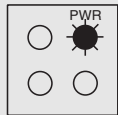

Indication of the gateway address for the RPI internal bus

## LED INT (red)

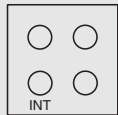

Internal bus in normal operation

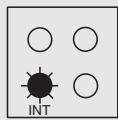

Internal bus or device error

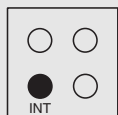

Internal interface error

## LED EXT (yellow / red)

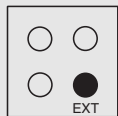

Yellow LED: external bus in normal operation

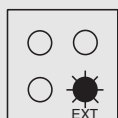

Red LED: no communication on external bus

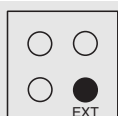

Red LED: internal interface error

**LED COM (red)**

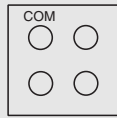

Normal condition: internal CAN bus in differential mode

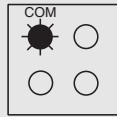

Internal CAN bus in common mode, redundancy failure

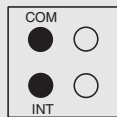

RAM/ROM/EEPROM error, or other internal error

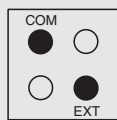

RAM/ROM error, or other error (red EXT LED lights)

11.4 Error Messages on the RPI Devices via LED

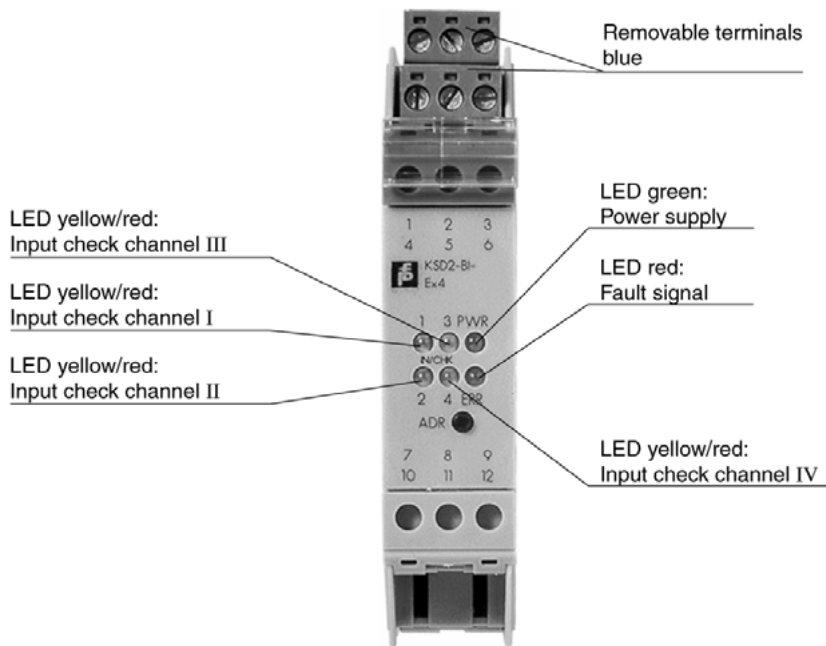





Figure 11.2: Front view of RPI device



The RPI system devices are provided with 1, 2 or 4 input and output channels depending on the model. The construction, the operation of the devices with the ADR button (address) and the LED display is identical for all types.  
A IN/CHK or OUT/CHK control LED is available for each individual channel.

The following symbols are used:

-  LED off
-  Flashing LED
-  LED constantly illuminated

**LED PWR (green)**

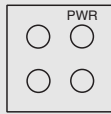

No voltage supply

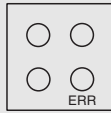

Voltage supply present

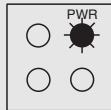

Setting and checking the device address

**LED ERR (red)**

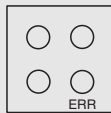

No error

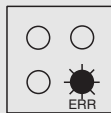

Bus error

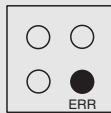

Hardware error (specification via IN/CHK or OUT/CHK LEDs)

**IN/CHK or OUT/CHK LED(s)(1 ... 4)**

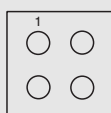

Input/output channel 1 not active

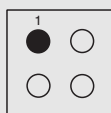

Yellow LED: input/output channel 1 active

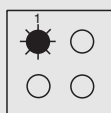

Red LED: lead breakage or short-circuit of the field circuit, channel 1

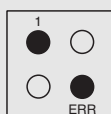

LED 1 (red) and ERR-LED: EEPROM error

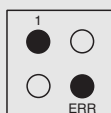

LED 1 (yellow) and ERR-LED: communication error

---

## K-SK1 - THE MAN/MACHINE INTERFACE FOR THE CONFIGURATION, PARAMETERISING, SIMULATING TESTING AND MONITORING THE RPI

---

### 12 K-SK1

#### 12.1 General

##### 12.1.1 Computer related font

Computer related items like keys, software buttons, menu items, etc. are written in `courier` font.

The presentation of menu items is `menu ? menu item`. If the menu item is depending on the active window but unambiguous it is represented by `menu ? (?)`.

The  and  symbols note that the described action relates to that input device.

##### 12.1.2 Hardware requirements

To run K-SK 1 you need at least an IBM-compatible PC with 486-CPU, 8 MB RAM (16 MB RAM recommended), 5 MB free harddisk space, and a free serial port. Find out the COM-port-number of this free port since you have to set up your software accordingly.

##### 12.1.3 Operating system

K-SK1 runs under Windows 3.x, Windows 95 and Windows NT 4.0

##### 12.1.3.1 Installation process

Insert disk #1 into a disk drive and start Setup.exe. An installshield guides you through the remaining installation process.

#### 12.2 Using the Software

##### 12.2.1 The advantage of using software

K-SK1 let's you configure a complete RPI system or upload an existing configuration. The advantage of the software is that you can multiply this configuration as many times as you want. This is a valuable feature in production processes

##### 12.2.2 Setting up a complete system

The recommended way of setting up a complete RPI system is to plan the structure of the system with a PC. The gateway and all devices are configured first in the PC, then the hardware in the control cabinet is set up. After configuring the project in the software, you have to download the configuration into the gateway. When setting up the hardware you can do it in either one of those ways:

Download all device information at your desk, then insert the devices into your cabinet. Or insert your configured gateway into the control cabinet and add the devices in the order of your project.

##### 12.2.3 Monitoring and Diagnosis

K-SK1 allows you to monitor the state of the devices connected to your PC via the gateway. You can also have a diagnosis of the connected devices or simulate their inputs and outputs, or their error messages respectively.

##### 12.2.4 Changing system information

You can edit the information stored in each device by software. K-SK1 also allows you to save this information on your PC. This storage is of great use as a system backup for the case you have to exchange components later.

#### 12.3 K-SK1 Operation manual

This part guides you through the configuration process of a RPI system. It shows you how to use the project manager and the tools provided.

##### 12.3.1 Starting the software

Double click the K-SK-icon.

Select the language and operation mode in the dialog box coming up. Use specialist if you need to set up a new project or edit an existing one otherwise select maintenance. If you select specialist mode you might be asked for a password when you try to establish a connection to the gateway. If you do not possess the password, exit the program and start in maintenance mode. Confirm your choice with OK.

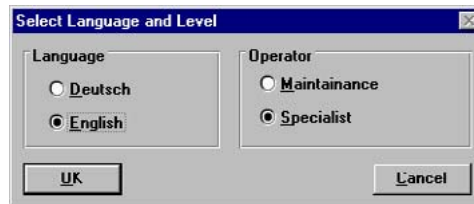

### 12.3.2 The main screen

After fully loading the program, the screen displays this window:

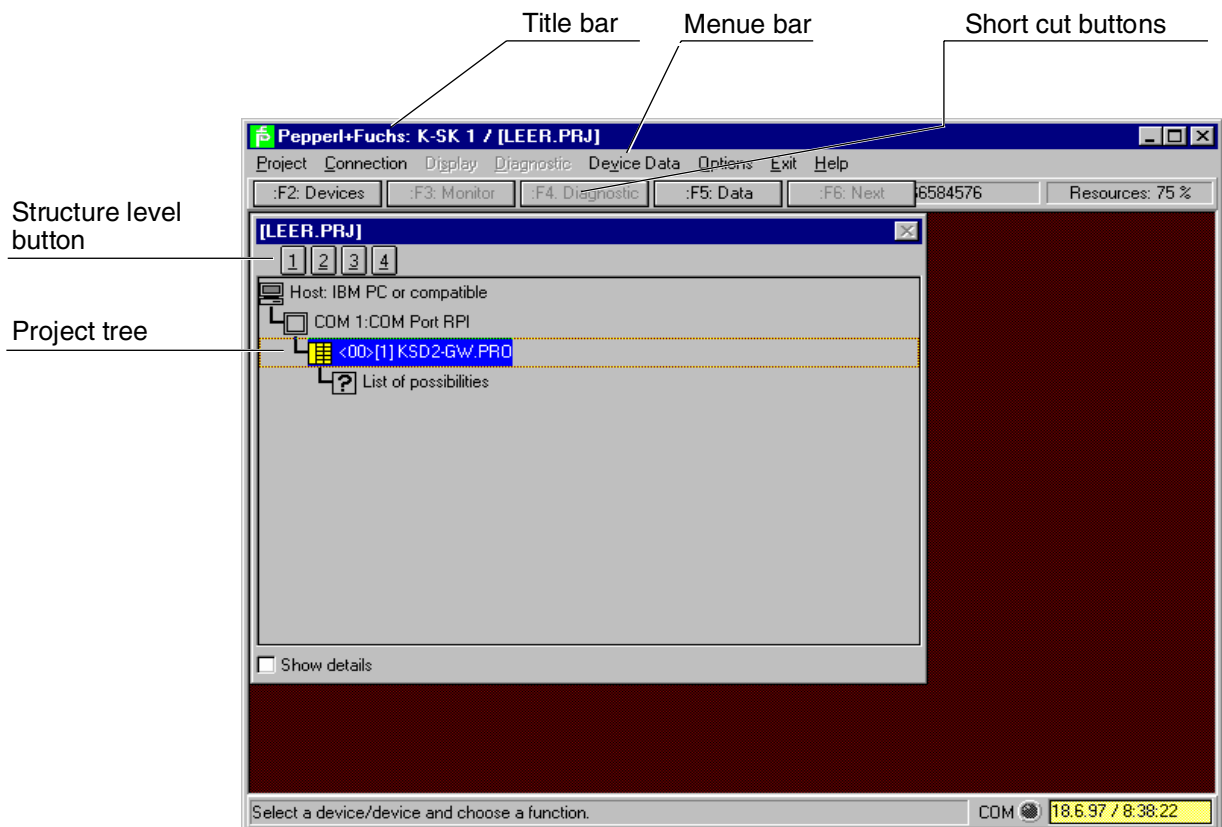

The K-SK 1-software contains some Windows specific elements (close box, etc.). Please refer to the Windows manual for help on their function and use.

#### 12.3.2.1 The project manager

The window inside is called "project manager". It displays the current project tree and let's you select devices for monitoring, diagnosis, or simulation. It provides a title bar, four structure level buttons, scroll bars if necessary and a "show details" check box.

The icon of the selected item is displayed in yellow.

#### 12.3.2.2 The menu bar

The menu bar gives you full control of the program. You can start any action you like to perform from the menu bar by selecting the right menu items. The content of the menu bar and the availability of menu items may change depending on the active window below.

### 12.3.2.3 The short cut buttons

These buttons are short cuts to menu items. Some of the buttons may not always be available. You can use them instead of the menu bar. Note that not all functions have a short cut.

### 12.3.2.4 The title bar

The title bar of this window states the name of the present project.

### 12.3.2.5 Selecting an item



Click onto the item with the left mouse button.



Use the cursor keys to move up or down to the item. The up and the left key move to the item above, the down and the right key to the item below.

### 12.3.2.6 The structure level buttons

The four structure level buttons below the title bar control the level of the presented structure. Level 1 is the serial port level, level 2 the gateway level, level 3 the RPI devices level, and level 4 the channel level. If you need to see the full information of the device tree make sure that level 4 is selected. The use of those buttons is simple:



Click onto the structure level button with the left mouse button. The whole tree is expanded or shrunk to that level.

If you want to expand or shrink only parts of the tree you have to double click onto the item with the branch to change. If nothing happens your selected item does not have a minor structure.



Use the cursor keys to navigate in the tree. Up and left select the item above, down and right select the item below. Use enter to expand or shrink a branch.

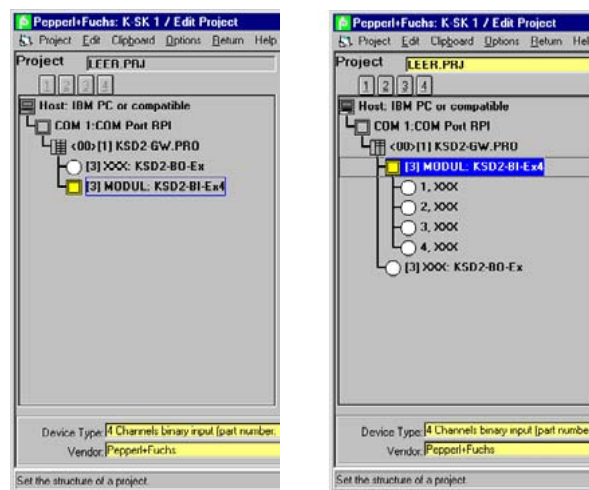

You can choose the details of information by selecting different structure levels. The picture above shows a device tree in "level 3" and "level 4".

### 12.3.2.7 The "Show details" check box



If you check this box by clicking into it, the project manager window separates into two parts. The lower part provides you with additional information about the selected item of the top part. You deactivate this option by deselecting the check box.

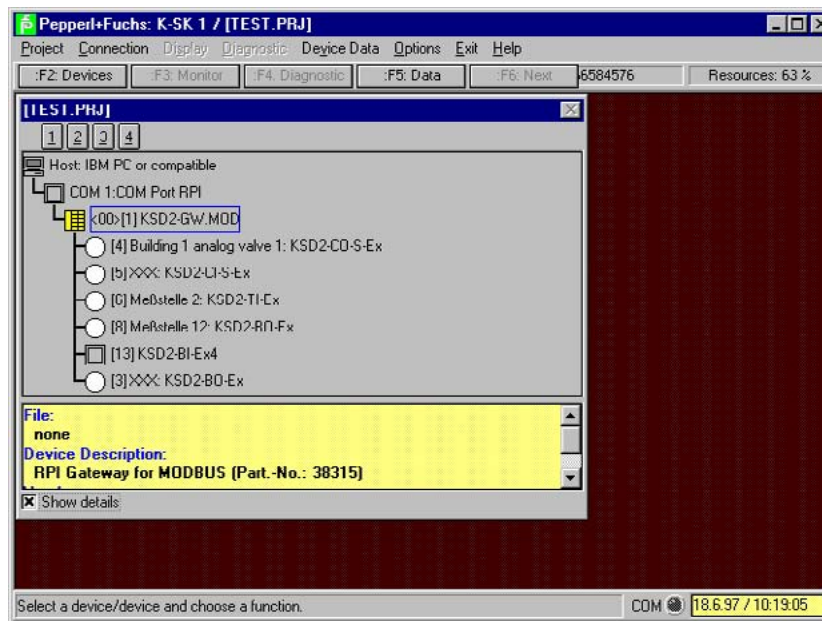

### 12.3.3 Handling the project

You need only a few functions to fully handle a project in K-SK 2. Besides opening and saving a project, the most important function is to edit the current project displayed in the project manager. This section describes only the basic set up. The normal operation of RPI including monitoring, diagnosis, and simulation is described later.

#### 12.3.3.1 Overview

This section is only an overview to give you an impression of the standard workflow. The following sections will describe each of the steps more detailed.

To create a new project do the following:

1. Create a new project
2. Save the project under the name you want the project to be referred to.
3. Edit the project in edit mode
4. Save all the changes to that project

When finished you might want to configure your gateway accordingly. To do so:

1. Make sure that your gateway is powered and correctly connected to your PC.
2. Choose `Project ? download`.

By now you have a correct set up in your PC and your gateway. You can build your cabinet right now by adding device by device to the cabinet. They will be configured according to that project laid down in the gateway.

#### 12.3.3.2 Creating a new project

Select `Project ? New` from the menu. The project manager is reset and the project name is set to `noname.prj`. See "Editing a project" for more information about changing the project information.

### 12.3.3.3 Opening an existing project

Select **Project ? Open** to load an existing project into the project manager. If you have another project open that contains changes you want to keep use **Project ? Save** or **Project ? Save as...** first.

### 12.3.3.4 Saving a project

To save a project select **Project ? Save** or **Project ? Save as**. The latter lets you change the name of the project, if you do not want to overwrite an existing project with the changes made. A valid name contains up to 8 characters and the extension ".prj". If you do not need to add the extension. In this case K-SK1 will add the extension automatically. If you save a project for the first time it's always "saving as ...".

### 12.3.4 Editing a project

To edit a project select **Project ? Edit** from the menu and the edit window appears. You have full control over the project tree in this window. You can add or delete devices or whole branches and it also lets you configure the basic information like the slave address or tag name of each device.



Note

*The order of the devices in the tree does not have to be identical with the order in the cabinet. The devices are addressed by their slave address, not by their physical order. Therefore it is not important where they are located in the device tree. (However, the device tree is sorted by slave address.)*

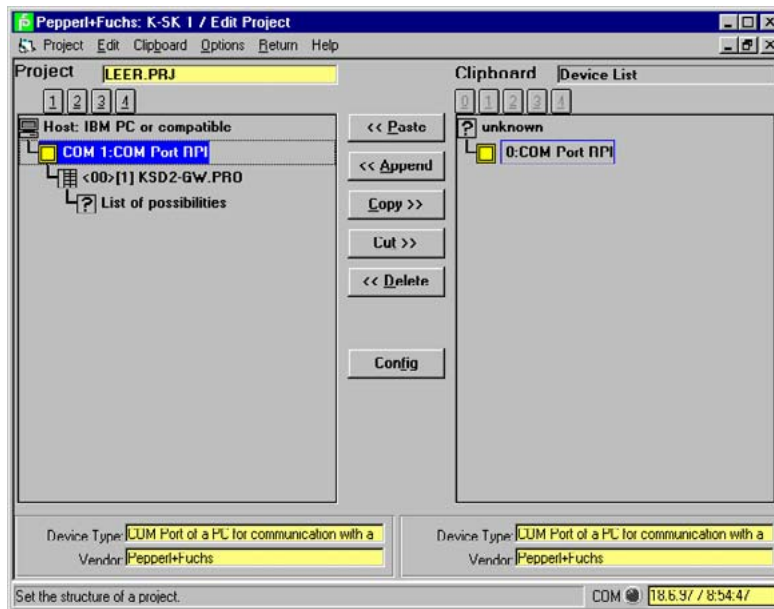

#### 12.3.4.1 The three parts of the edit window

##### **PROJECT (LEFT)**

This part of the window shows you the present project as is. You can select items that should be copied into the clipboard or removed from the project and you can also configure the selected item.

**CLIPBOARD (RIGHT)**

The clipboard has three different views: The copy view, the project view and the device list view. The copy view is suitable if you have to copy parts of your project. Instead of adding piece by piece to your project you copy the part into the clipboard and add it to the project again as often as you want. This method works for single items as well as for whole branches or trees. The project view opens a former project and you can copy the whole project into your current one or any part you like. If you want to change the content of this view select `Clipboard ? Open Project`. The device list offers you a complete list of devices you may add to your project. The content is depending on the selected item and gives you a choice of suitable devices.

**BUTTONS (MIDDLE)**

You can copy, cut, or delete selected items by clicking onto the buttons. If they are not available they are shaded in gray. The direction indicated by “<<” and “>>” means that the window in this direction is affected.

**12.3.4.2 Selecting the active part of the window**

 Click into the window part you want to activate.

 Press tab to switch between the two window parts.

A blue ribbon marks the selected item in the active part of the window.



**SELECTING ITEMS**

The selected item is highlighted in yellow and blue. To select an other item

 click onto the new item.

 move the marker with the cursor keys. The cursor up and the cursor left move the marker up, the cursor down and the cursor down move it downwards.

 +  To select more than one icon at the same time press down the shift key or the control key.

 +  With the shift key you select the whole range between the already selected and the new selected item. Using the control key let's you choose item by item.

**USING THE BUTTONS**

To activate any button

 click onto the button.

 use the `⌘` key + the underlined character.

**12.3.4.3 Getting help**

If you need additional help you can select `Help ? Contents` or search for help on...

**12.3.4.4 Undoing changes**

There is no undo function available. Please make all changes to your project carefully and use the save function frequently. This helps you to avoid undesired additional work.

**12.3.4.5 Adding a device**

Select the place in the current project where you want to add the new device or branch by selecting a device before or after that desired place. Then select the device you want to add in the clipboard view. Press paste if you want to add it before the selected device or append if you want to add it behind the selected device position. It is also possible to choose `Edit ? Paste`. After you added the device(s) you should configure it.

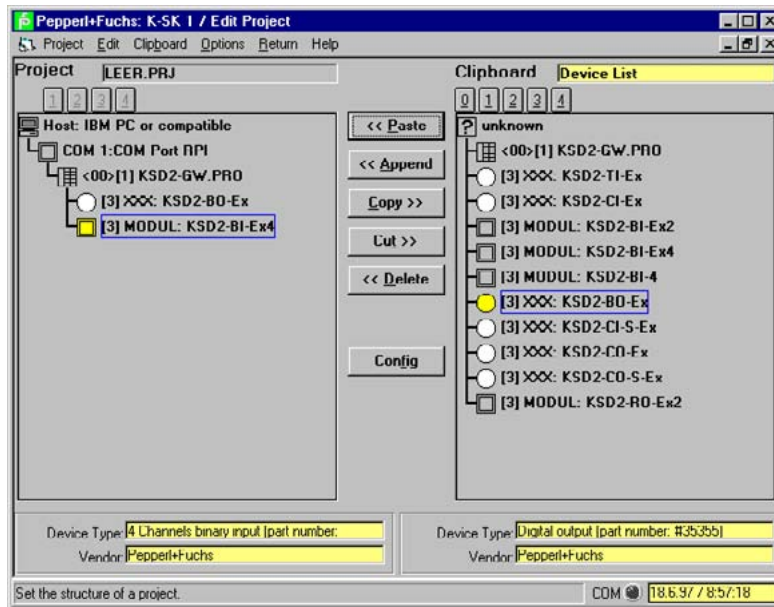

Starting point: The selected device is highlighted. Paste and Append are relative to the selected item. Paste will add the new device in front of the selected item, append will add it behind.

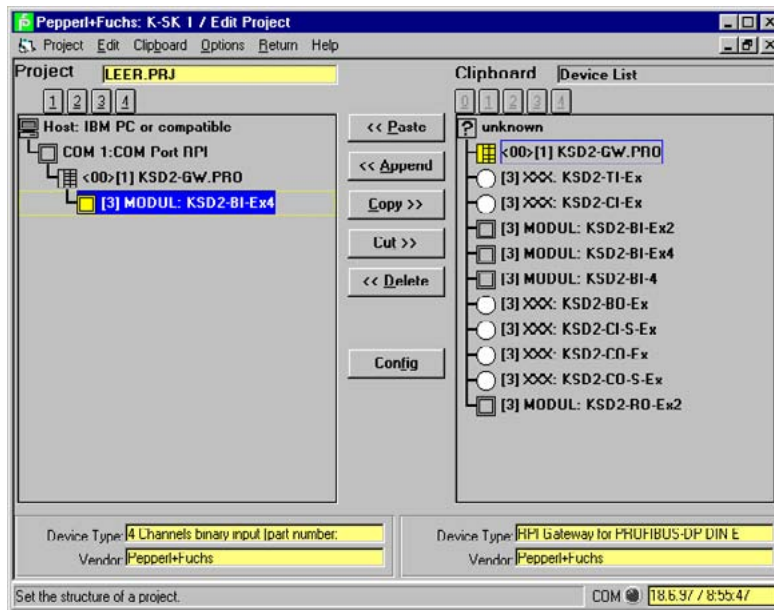

A new device is pasted. The new device is right in front of the selected one.

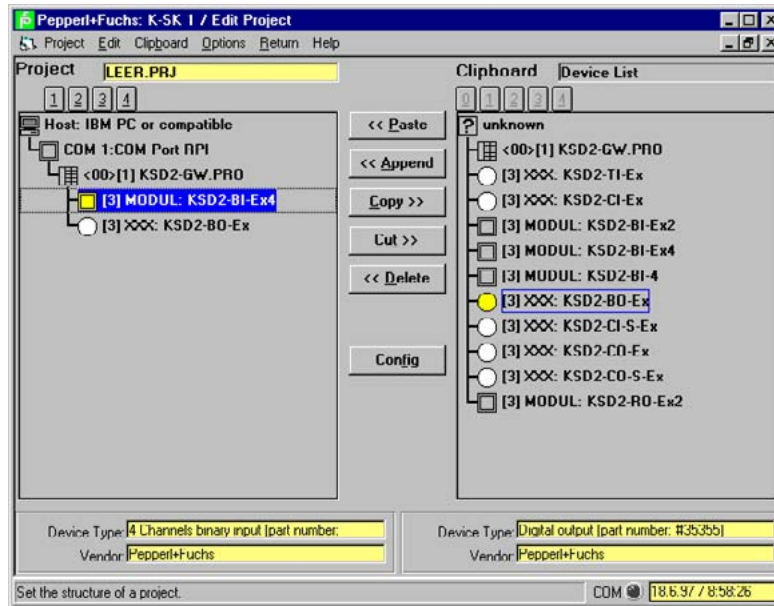

A new device is appended. The new device is right behind the selected one.

#### 12.3.4.6 Configuring a device

Select a device of the project and press the button config. The clipboard view is closed and a configuration window with tab strips opened.

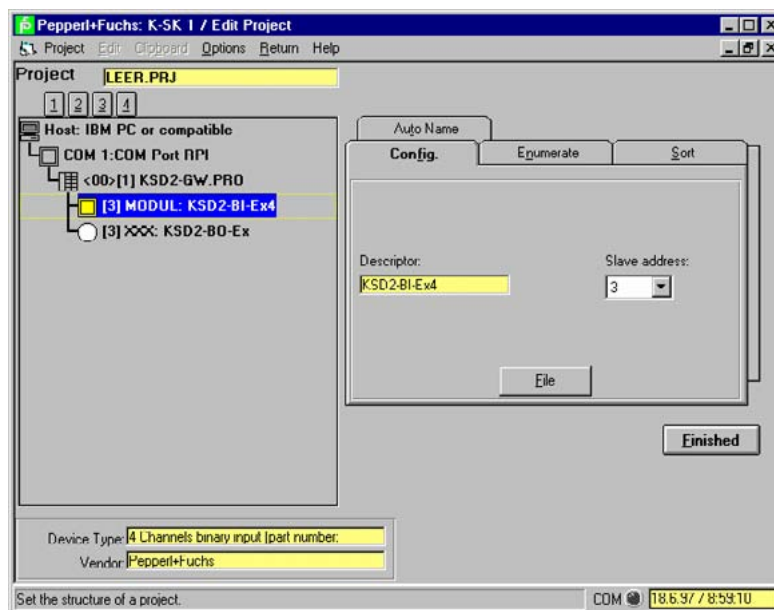

The first tab strip is Config. It allows you to set the RPI-Address of the device or the channel number if you have selected a channel. It also allows you to type in a descriptor (tag name) for the device or channel. It may contain up to 28 characters. This is helpful for larger projects to identify the devices clearly.

The Enumerate tab strip is useful in numbering channels.

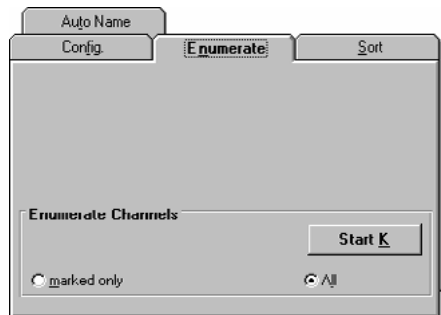

You can automatically number the channels consecutively by pressing the button Start K. If you choose to enumerate a range of modules, the channels of each module are numbered separately starting from 1.

The Sort tab strip is not implemented in this version.

The last tab strip is Auto Name which allows you to fill the TAG field of all devices with a string and an automatically added number.

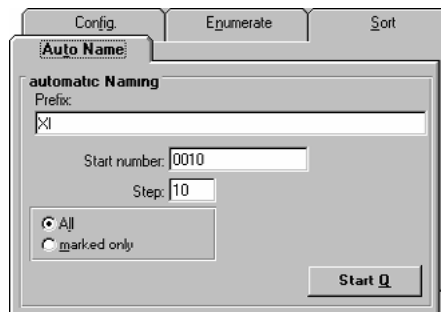

Unlike enumerate the Auto Name function influences all devices. You cannot select a range!

The auto name function is started by pressing the Start Q button.

After you have finished the configuration press Finished.



Note

*This is only a basic set of information stored in the devices. Use Device Data ? Edit Device Data to edit the complete information of the device. Refer to section XX to find out how to edit the full information stored in the devices.*

#### 12.3.4.7 Removing a device

Before you remove a device make sure that you selected the correct device(s). There is no undo function available.

There are two ways to remove a device or branch out of the current project. You can either use delete or cut. Delete removes the device definitely from the project, cut changes the clipboard view to copy and displays the cut part of the project.

#### 12.3.4.8 Printing a project

Select Project | Print to print the current project. If you need to configure your printer choose Options ? Printer configuration. The printout contains the full project tree plus some additional information.

#### 12.3.4.9 Exiting the edit window

Select Return ? Close and Return to Main Menu. The edit window is closed and project manager activated again.

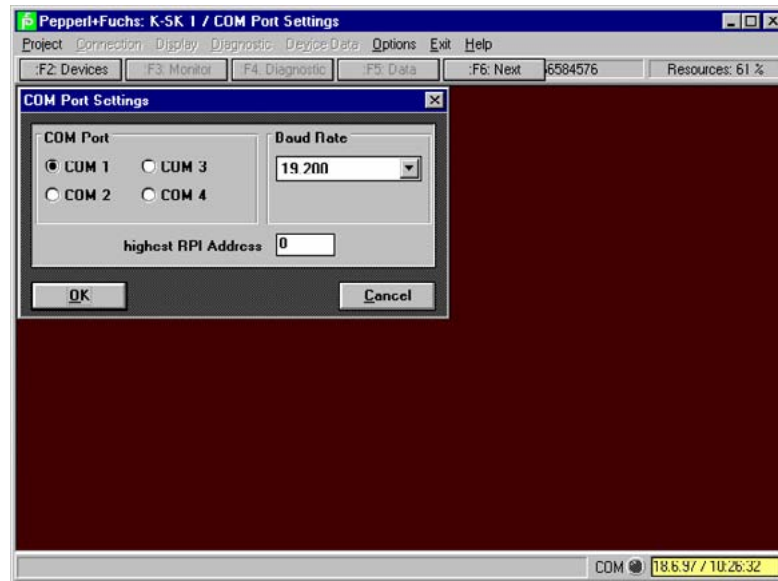

### 12.3.5 Connecting your PC with the RPI hardware

#### 12.3.5.1 Connection

Use the K-ADP2 respectively the K-ADP4 interface adapter to connect your PC or laptop and the gateway.

#### 12.3.5.2 Setting the serial port

Select the com-icon in the project and select *Device Data ? COM Port Settings*. Enter the serial port you have connected to the hardware and adjust the baud rate accordingly. Confirm with OK.

#### 12.3.5.3 Starting the communication between K-SK1 and RPI

Select the gateway in your project. This makes the menu *Connection* available.

Select *Connection ? Establish Connection*.

If you are working in service mode you might be asked to enter a password if the option is activated in the gateway. Setting this option is described in section XX. Confirm your password with OK.

This password does not appear in maintenance mode. If you do not possess the password, exit the program and start in maintenance mode again.

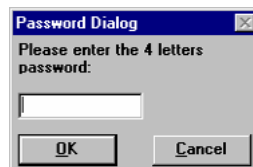

The next dialog box appears, if the project configuration in your PC differs from the hardware setup.



Select yes if you want to upload the hardware configuration into your present project, no otherwise.

If the project and the configuration of the gateway are the same or you chose to upload the configuration, a dialog box appears stating that the connection is established.



All devices appear in black bold letters in the program manager. If there is a difference between the configuration in the gateway and software or a device is not working correctly, the affected device appears in red letters.

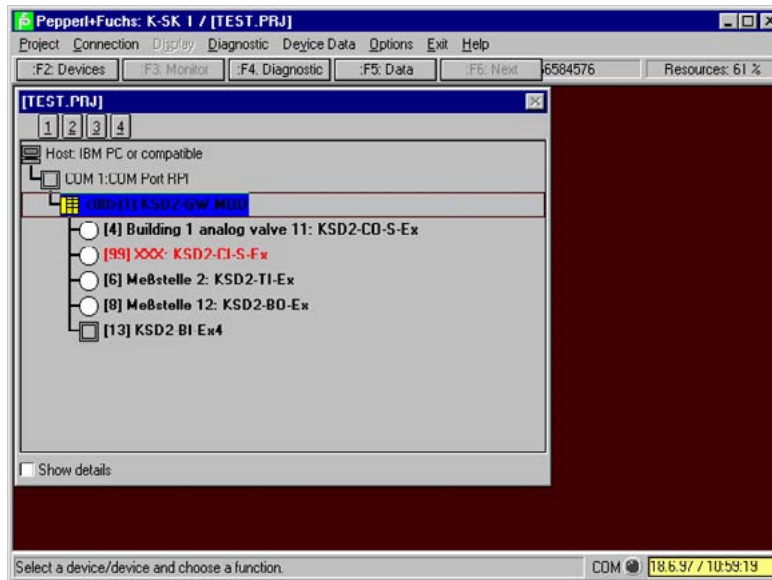

#### 12.3.5.4 Closing down the communication between K-SK 1 and RPI

Select the gateway in the project manager then **Connection ? Go Off Line** to shut down the communication. The communication is also shut down, if you select **Project ? Edit** during operation. After the connection is shut down, the devices in the project manager are displayed in normal letters again.

#### 12.3.6 Editing Device Data

There are two ways of editing device data: online and offline. In the first case you load and save the data directly from and to the device (with a possibility to save it to a file, too), in the second case you load and save the data from and to a file on your computer. K-SK also allows you to load the data from a device and save it to a file or vice versa.

The difference between both methods is the updating of the project. The project is automatically updated if you save changes to the device. If you save information only to files you have to update the project by downloading the new information with **Project ? download**. In this case the project uses all data files (extension .dat) related with that project to rewrite the device information.



Note

*If you close the window containing device data, a dialog will prompt asking you whether you want to save the information in a file or not. Confirm with yes if you want to save the information into a file, no if not. If you close the window without saving to the device or a file, your information is lost afterwards.*

#### 12.3.6.1 SELECTING THE DEVICE

Click onto the device which contains the data you want to change. Select **Device Data ? Edit Device Data** or click onto **i Data**.

Select the device by moving the marker with the cursor keys. Press either **i** or **↑+v** then **↑+e**.

#### 12.3.6.2 Changing data

The available data is device-dependent. Your edit window may look different for each device. Also the content of the tab strip may vary. You are only able to change white or gray text fields on the tab strip. To change a field content click into the field. Then do your changes.



After you are finished, always save the changes.

### 12.3.6.3 Changing between the tab strips



click on the tab strip you want to edit.



use **Alt** + the underlined letter of the register tab strip you want to edit.

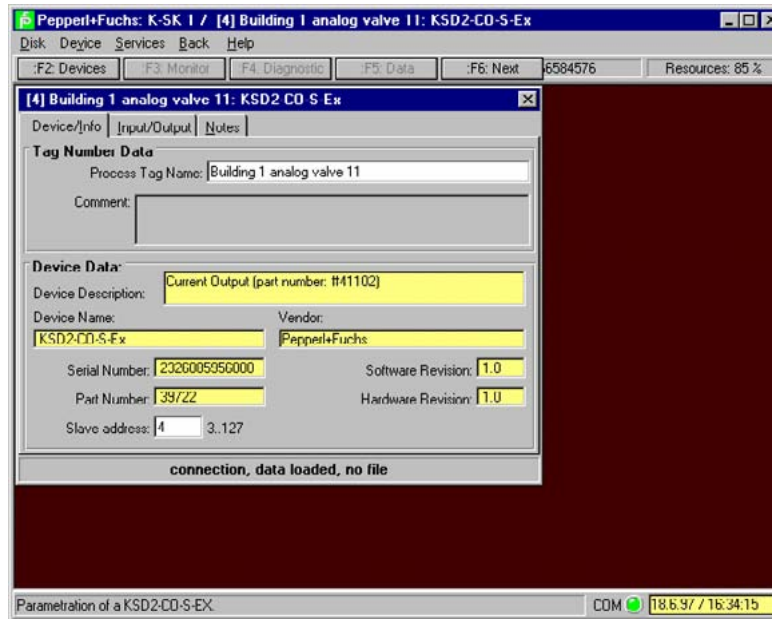

The display after selecting **Device Data** ? Edit. The content of the window may vary.

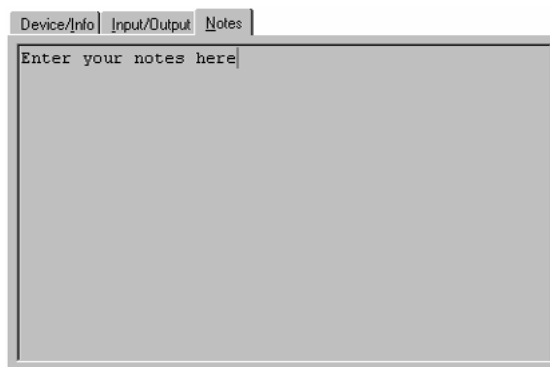
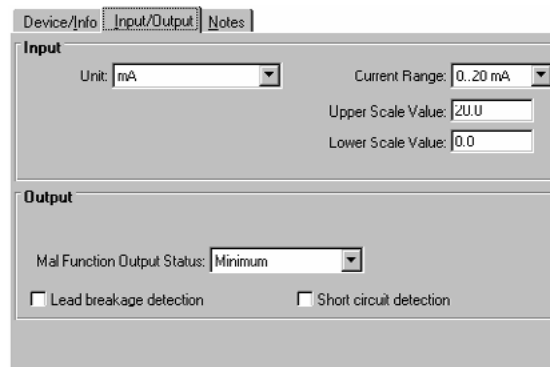

Two other example tab strips.

### 12.3.6.4 Setting a password

The tab strip contains a part "Password/Panel". You can set two different passwords here. Both will be activated when you check the box "Password active" and save the information in the gateway. You need to know only one password of the two passwords to get access to a protected gateway, since both passwords are equal and have the same function.



Note

*If you are using passwords, avoid using "empty" password boxes. Make sure that both passwords are set.*

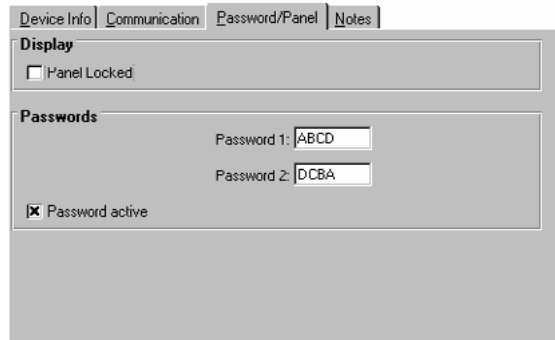

### 12.3.6.5 Saving data

If you want to save the data to the device

select `Device ? save to Device`.

use `⌘ + v`, then `⌘ + s`.

To save the data into a .dat-file

select `Disk ? save to Disk`.

use `⌘ + d`, then `⌘ + s`.

Enter a file name with up to 8 characters plus the extension ".dat" and press OK. The project file contains a list of all related data-files. If you do a download, the project manager uses the data-files to set the information of the according devices.

### 12.3.7 Downloading a project into a gateway

Use `Project ? Project Download` to download the present project configuration into the selected gateway. If you use this option, the gateway accepts this configuration as target configuration. Any different hardware set up results in error messages. To proceed with downloading, confirm the following dialog box with yes. After positive confirmation a connection to the gateway is established and the information processed. The connection shuts down afterwards.

### 12.3.8 Printing a project

Select `Project ? Print` to print the present project. If you need to configure your printer or want to use a different than the standard use `Options ? Printer Configuration` first.

### 12.3.9 Monitoring devices

You can monitor the output signals of all connected devices by selecting `Display ? (?)` but only if you have a PC connected to the RPI hardware, an established communication connection, and selected a device. If the menu `Display` or the button `Monitor` is not available, check the communication and select the device to be monitored.

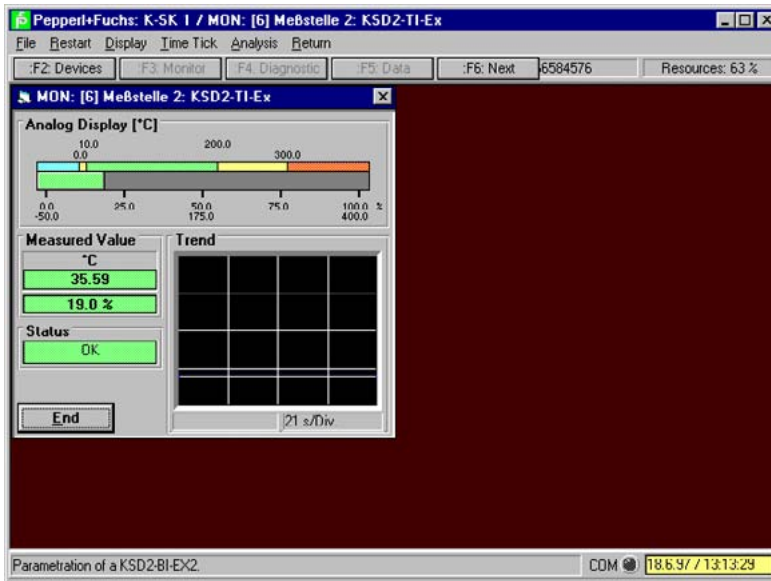

The big window shows a window for an analogue device the small window is an example of a binary device. If you chose to monitor an analogue device you can set the type of display. To see only the trend graph deselect display ? bar graph.

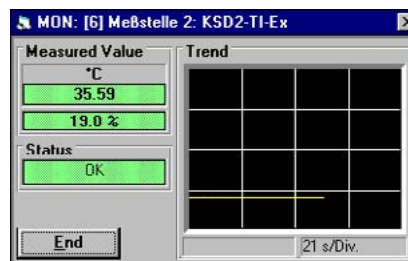

You may also hide the trend and see only the bar graph by deselecting display ? trend.

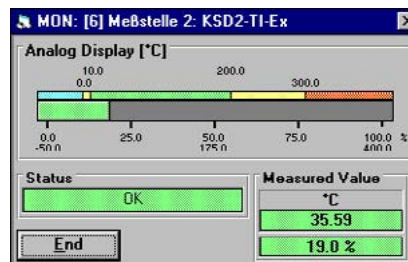

If you need further help on the content of the windows and the menu bar please use the online help.

### 12.3.9.1 Ending the monitoring

All windows can be closed by menu commands. Some windows may use the Back ? Close or Back ? Back to Main Menu command, others Return ? Return to Main Menu. Also some of the windows may have an end button which closes the window when clicked.

### 12.3.10 Diagnosis of devices

If an error occurs (e.g. lead breakage, limit value exceeded, etc.) the device will be shown in red in the project. To get information about the error use `Diagnostic ? all Diagnostics`. Of course you can use diagnostics also with fully working devices.

Using the diagnostics is only possible with the PC connected to the RPI hardware, an established communication connection and a selected device.

To start the diagnostics select a device in the project manager and do one of the either way: press `î`, select `Diagnostic ? all Diagnostics` or click the `î Diagnostic` button.

The diagnostics window opens.

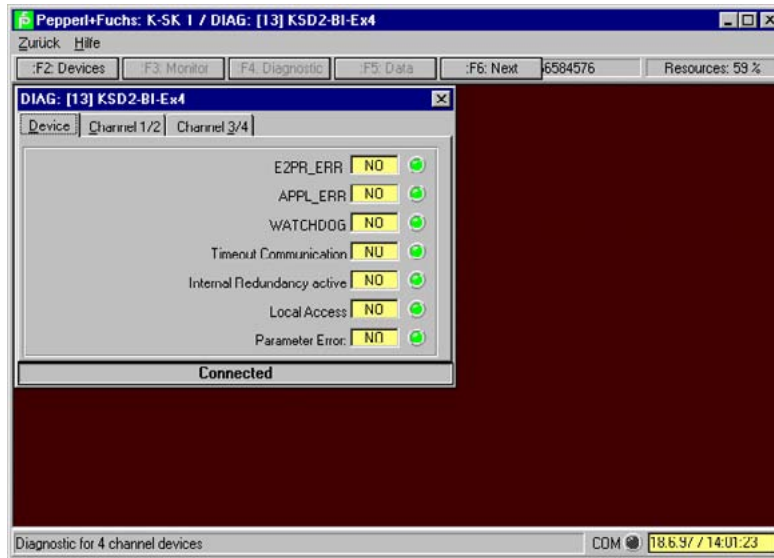

The content of the windows should be self-describing. If you need further information about the content use the online help.

#### 12.3.10.1 Ending the diagnostics

All windows can be closed by menu commands or the close symbol in the top right corner. Some windows may use the `Back ? Close` or `Back to Main Menu` command, others `Return ? Return to Main Menu`. Also some of the windows may have an end button which closes the window when clicked.

#### 12.3.10.2 Simulating devices

Simulation plays an active part in a process. A simulation of the input values can pinpoint undesirable reactions in the control system, PLC, or PC system. A simulation of the output values initiates the actuators, opens valves and control pumps!

A check should be made, in any case, prior to starting the simulation, that no system endangering or undesirable conditions a likely to arise.



Confirm the warning with OK to proceed, to abort the action select Cancel. If you proceed you are asked to choose the features you want to simulate. There are three options available: Process Value, Device Specific Diagnostic, and Channel Specific Diagnostic.

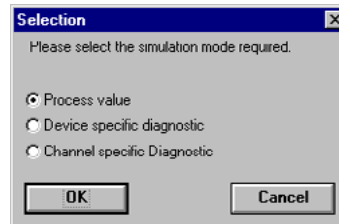

### 12.3.10.3 Process Value

If you choose Process Value you are allowed to change the state of the inputs and / or outputs. Select the feature and confirm with OK.



You change the switching state of binary inputs / outputs by clicking onto the according switch or the led of the state you want to set. With analogue devices you will find a drag bar to change the values. Just drag the button to the desired value or write down the value into the according field.

### 12.3.10.4 Device specific diagnostic

With this option you simulate the error signals of the devices.

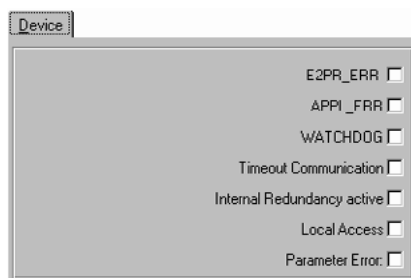

The simulation is straight forward: a checked box means that the according error signal is set. Reset the signal by clicking into the box again.

### 12.3.10.5 Channel specific diagnostic

The function principle is the same as with the device specific diagnostic. Again a checked box means that

the according error signal is set, a non-checked box means that the signal is not set.

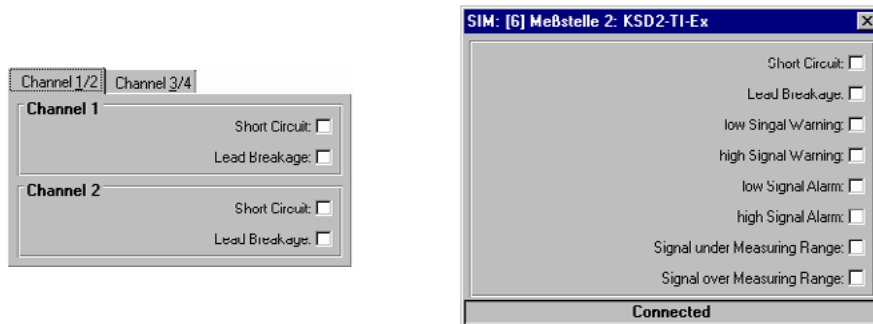

Two examples of channel specific diagnostic windows. The content is device dependend.

### 12.3.11 Other program options

#### 12.3.11.1 Setting basic program options

Select *Options ? Setting* to set basic program options.

If you have selected "Project manager always on top" the project manager window is always displayed. If you do not check this option, the project manager window is closed when you open a diagnosis or a monitor window.

The option "connection establishment read tag names on connection" determines whether additional information is transmitted between PC and gateway during the connection establishment or not.

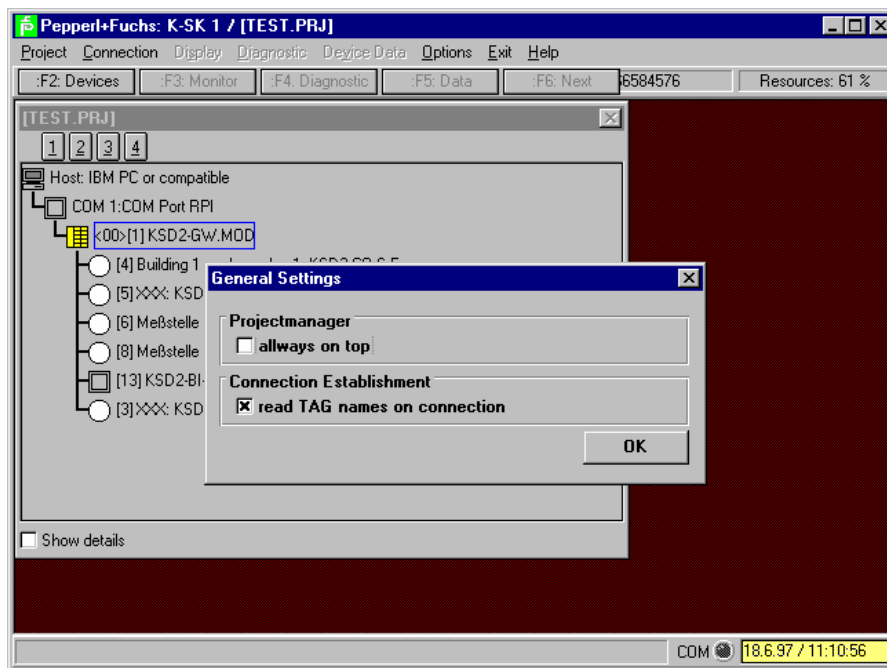

#### 12.3.11.2 Getting help

Use *Help ? Contents* or *Help ? Search For Help* on to get the build in online help.

### 12.3.11.3 Finding out the version of your software

Select `Help ? About K-SK 1`. A dialog appears, stating the version.

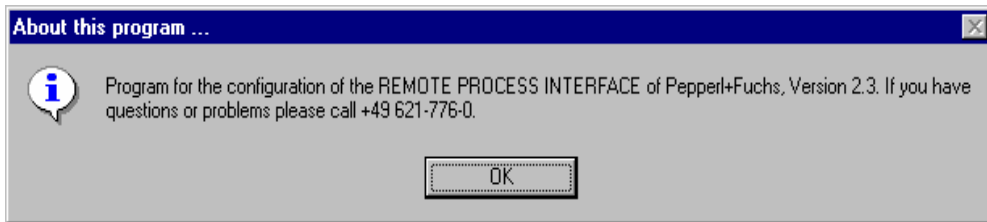

Confirm with OK to close the dialog box.

### 12.3.12 Exiting the K-SK1 software

Select `Project ? Exit` or `Exit ? Exit Program` to close the program.

You can also use the close box of Windows.

If you have made any changes to the project you want to keep, make sure to save the information first. If you confirm the dialog box with OK the program is quit and all unsaved data lost.

**13 Glossary**

0x	Hexadecimal representation
ADR	Address
CAN bus	RPI internal data bus
CH	Channel
CHK	Check
COM	Communication
COM	Communication Object Model
DCOM	Distributed Communication Object Model
DDLML	Direct Data Link Mapper
DC	Direct Current
DP	Distributed Peripherals
E/A	Eingang/Ausgang = I/O Input/Output
EEPROM	Electrical Erasable and Programmable ROM
EMC	Electromagnetic Compatibility
ERR	Error
Ex side	Side of a device from which circuits lead to environments in which explosive atmospheres can arise
EXT	External
FDL	Fieldbus Data Link
FMS	Fieldbus Message Specification
GND	Ground
DTM	Device Type Manager
FDT	Field Device Tools
h	Hexadecimal representation
HART	Highway Addressable Remote Transducer
I/O	Input/Output
ID	Identification
INT	Internal
LCD	Liquid Crystal Display
LED	Light Emitting Diode
LSAP	Link Service Access Point
LSB	Least Significant Bit
MSB	Most Significant Bit
MSR	Mess-, Steuer- und Regeltechnik = Measuring and Control Technology

PC	Personal Computer
PHY	Physical Layer
DCS	Distributed Control System
PWR	Power
RAM	Random Access Memory
ROM	Read Only Memory
RPI	Remote Process Interface
SAP	Service Access Point
SCADA	Supervisory Control and Data Acquisition
SMART	Self Monitoring Analysis and Reporting Technology
PLC	Programmable Logic Controller
Tag Number	Measuring point description
USV	Unterbrechungsfreie Stromversorgung = UPS Uninterruptible Power Supply

# PROCESS AUTOMATION – PROTECTING YOUR PROCESS



## Worldwide Headquarters

Pepperl+Fuchs GmbH  
68307 Mannheim · Germany  
Tel. +49 621 776-0  
E-mail: [info@de.pepperl-fuchs.com](mailto:info@de.pepperl-fuchs.com)

For the Pepperl+Fuchs representative  
closest to you check [www.pepperl-fuchs.com/pfcontact](http://www.pepperl-fuchs.com/pfcontact)

[www.pepperl-fuchs.com](http://www.pepperl-fuchs.com)

Subject to modifications  
Copyright PEPPERL+FUCHS • Printed in Germany

 **PEPPERL+FUCHS**  
*PROTECTING YOUR PROCESS*

043014 / TDOCT-0129B  
03/2005



# SCATTERGOOD & JOHNSON LTD

ELECTRICAL ENGINEERING & FLUID CONTROL DISTRIBUTORS

Est.1899

At Scattergood & Johnson Ltd, we pride ourselves on being a technical distributor to specialist industries.

Working with a range of quality product suppliers across a number of specialist markets, we are not your average 'box shifter' - we are your technical and supply chain partner.

We fully support every product we sell - for free! Our internal team and external sales engineers can answer any product or application question, no matter the complexity.

Backing up this technical ability is a range of 50,000+ products available from stock for nationwide next day delivery (same day if required!), or you can collect what you need from any of our trade counters around the UK.

Select your specialist interest below to learn more about how we can help.

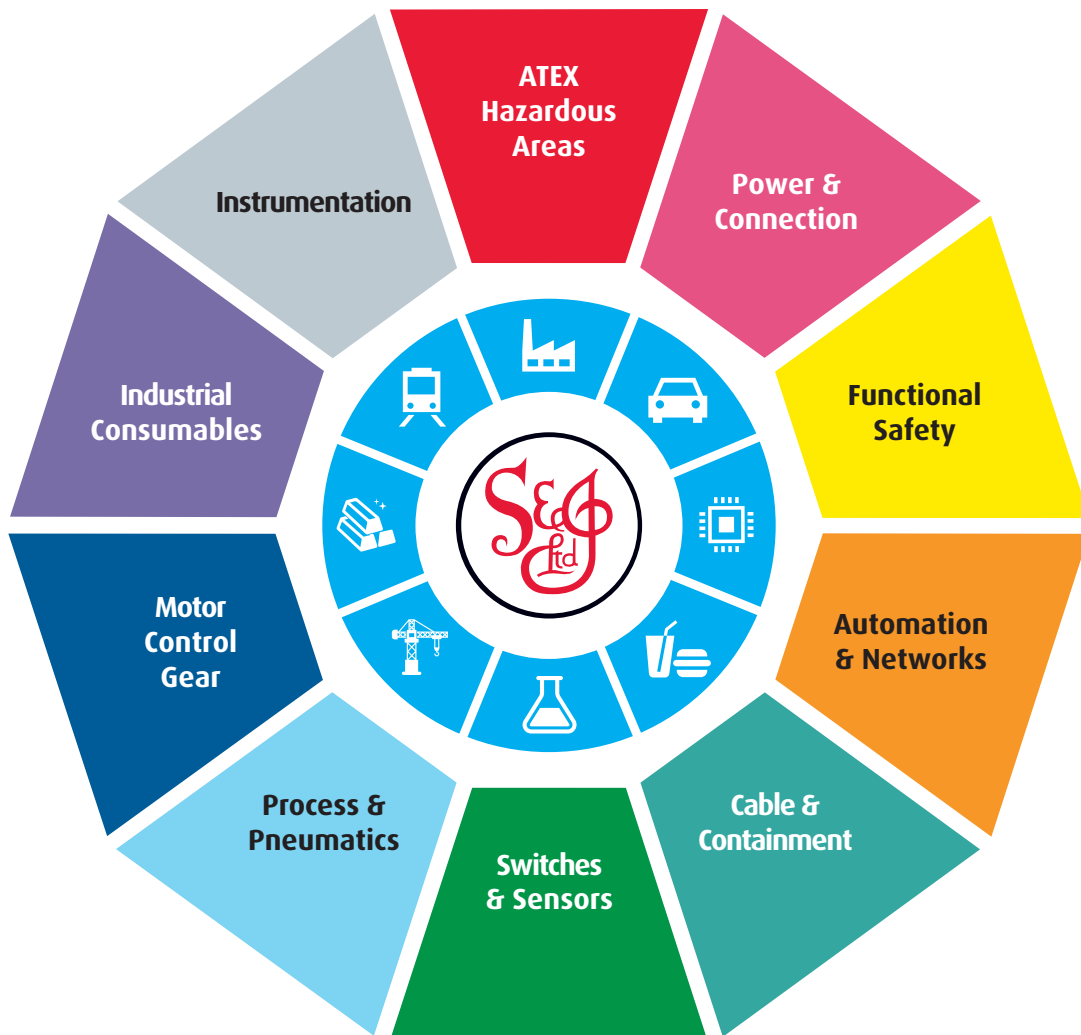

Online, In Branch and On the Road - Scattergood & Johnson Ltd, there when you need us.

# [www.scatts.co.uk](http://www.scatts.co.uk)