

MANUAL

# Temperature Converter with Trip Values KF\*\*-GUT-(Ex)1.D

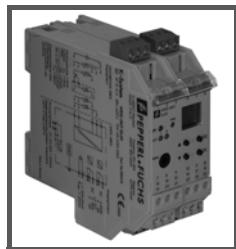

With regard to the supply of products, the current issue of the following document is applicable: The General Terms of Delivery for Products and Services of the Electrical Industry, published by the Central Association of the Electrical Industry (Zentralverband Elektrotechnik und Elektroindustrie (ZVEI) e.V.) in its most recent version as well as the supplementary clause: "Expanded reservation of proprietorship"

<b>1</b>	<b>Symbols used</b> .....	<b>3</b>
<b>2</b>	<b>Overview</b> .....	<b>3</b>
<b>2.1</b>	<b>Range of application</b> .....	<b>3</b>
<b>2.2</b>	<b>Variants</b> .....	<b>4</b>
<b>3</b>	<b>Safety instructions</b> .....	<b>5</b>
<b>4</b>	<b>Explosion protection</b> .....	<b>6</b>
<b>5</b>	<b>Use in safety applications (SIL)</b> .....	<b>7</b>
<b>5.1</b>	<b>Premises</b> .....	<b>7</b>
<b>5.2</b>	<b>Safe output states</b> .....	<b>8</b>
<b>5.3</b>	<b>Configuration</b> .....	<b>8</b>
<b>5.4</b>	<b>Regular testing of function</b> .....	<b>9</b>
<b>5.5</b>	<b>Evaluation of the device outputs using subordinate control systems</b> .....	<b>9</b>
<b>5.6</b>	<b>Features not suitable for safety-relevant applications</b> .....	<b>9</b>
<b>5.7</b>	<b>Firmware versions in combination with the safety function</b> .....	<b>10</b>
<b>6</b>	<b>Mounting and connection</b> .....	<b>11</b>
<b>6.1</b>	<b>Installation</b> .....	<b>11</b>
<b>6.2</b>	<b>Connection</b> .....	<b>12</b>
<b>6.3</b>	<b>GUT front side</b> .....	<b>15</b>

7	Display mode and error signals	16
8	Editing device data	18
8.1	Parameterisation mode control panel	18
8.2	Input	22
8.3	Unit	30
8.4	Output	31
8.5	Relays	31
8.6	Current output	36
8.7	Service	42
8.8	Default settings	43
8.9	Measuring ranges of the sensors	47

## 1 Symbols used



Warning

*This symbol warns of possible danger.*

*Failure to heed this warning may result in personal injury or death, or property damage, including destruction.*



Attention

*This symbol warns the user of a possible failure.*

*Failure to heed this warning can lead to total failure of the equipment and any other connected equipment.*



Note

*This symbol alerts the user of an important hint.*

## 2 Overview

### 2.1 Range of application

The K-System devices from Pepperl+Fuchs are used for transmitting signals between the field devices and the process control system/control system.

The devices marked with "Ex" in the type designation are suitable for the connection of field devices used in potentially explosive atmospheres. Field circuits for these devices are intrinsically safe and are galvanically isolated from non-intrinsically safe circuits. The devices thus establish an electromagnetic separation between the potentially explosive atmospheres and the safe areas in a system.

Devices without Ex-identification can be used to transmit signals between field devices and the process control system/control unit.

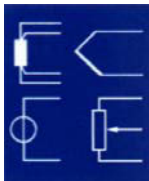

The KF\*\*GUT-(Ex)1.D of the K system (abbreviation: GUT) have been designed for temperature measurement applications.

In this context, a GUT converts the signal of an RTD, a thermocoupler, a potentiometer or a voltage source to a proportional output current which may, for example, be transmitted to a display unit or to an analog input of the process control system/control unit.

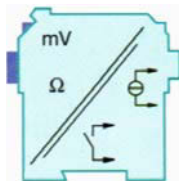

Two different, freely parameterisable trip values of the input signal can be monitored via the two GUT relay outputs.

It is also possible to process the modification of this signal per time unit instead of the input signal.

## 2.2 Variants

The following variants of the RTD are available:

KF\*\*GUT-\*\*1.D

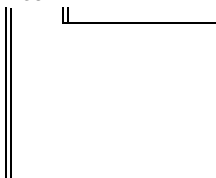

Ex = for the connection of field devices from the potentially explosive area

without identifying letter = for the connection of field devices in the safe area

D2 = with power pack for 24 V DC (green cover on the output side); as for the power supply via Power Rail with combined failure reporting please also refer to the "DIN-Rail Housing" catalog of Pepperl+Fuchs or to the "CD-ROM catalog".

U8 = with omni-voltage power pack, which allows for power supply with 20 V DC ... 90 V DC and 48 V AC ... 253 V AC without switching and without considering the polarity (gray cover on the output side)

### 3 Safety instructions



Warning

The KF\*\*-GUT-(Ex)1.D temperature converter may only be operated by trained professionals in a manner corresponding to this operation manual.



Warning

The protection of operating personnel and of the system is only ensured if the devices are used in accordance with their intended purpose. Any other type of operation than that described in this manual places the safety and functionality of the devices and systems connected to them in question.



Warning

The devices may only be installed, connected, and adjusted by electrical professionals **outside the explosion-hazardous area**.



Warning

If malfunctions cannot be eliminated, the devices must be taken out of operation and protected from being placed in service again inadvertently. Devices must only be repaired directly by the manufacturer Pepperl+Fuchs. Tampering with or making changes to the devices is dangerous and therefore not permitted. They render the warranty void.



Note

The responsibility for the adherence to local safety standards lies with the operator.

## 4 Explosion protection

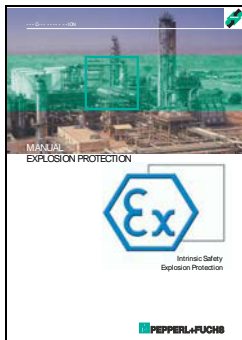

For primary explosion protection, that is, for measures to be taken to prevent or hinder the development of a dangerous explosive atmosphere, please observe the guideline 1999/92/EG (ATEX 137) or the corresponding national guidelines.

For secondary explosion protection, that is, for measures to hinder the ignition of a surrounding explosive atmosphere by electrical devices, Pepperl+Fuchs will gladly make the "Explosion Protection Manual" available to you for a nominal fee.

Note in particular EN 60079-0:2009, EN 60079-11:2007, EN 60079-15:2010, EN 60079-26:2007, EN 61241-11:2006, or the corresponding national guidelines.

Pepperl+Fuchs also offers a seminar on the topic of explosion protection.

## 5 Use in safety applications (SIL)

### 5.1 Premises

The base for use of equipment for safety applications is the SIL report P+F 05/03-24 R023. This report is available at [www.pepperl-fuchs.com](http://www.pepperl-fuchs.com).

The SIL report is based on certain assumed premises. On the part of the user, the premises listed below must be provided.

#### Repair time

While preparing the SIL report, it was assumed that, after occurrence of a visible fault (e. g. a relay de-energised), it would be repaired within 8 hours (e. g. by repairing a sensor burnout).

#### Testing time

One assumption in the calculations in the SIL report was that notification of a dangerous fault (e. g. output current outside the range of 4 mA ... 20mA) would be detected by the control system within an hour.

#### Low Demand Mode

The operation mode according to IEC 61508 assumed for the SIL report is the Low Demand Mode (for a definition, see IEC 61508, part 4, section 3)

#### Power supply

Failure of the external power supply was not taken into consideration and must be handled additionally when evaluating the overall safety function.

### Temperature conditions and testing times

The PFD values (PFD = Probability of Failure on Demand) of KF\*\*GUT-(Ex)1.D equipment lie within the range specified for SIL2 for the testing times given in the report. The PFD values were calculated based on the assumption of a mean ambient temperature of 40 °C. At a temperature of 60 °C the failure rate must be multiplied by a factor of 2.5. In practice, this means a correspondingly reduced testing interval. For mean temperatures between 40 °C ... 60 °C the factor can be adjusted linearly.

The test interval can be extended by connecting the two relay outputs. Here, the parameters for both relay outputs must be set to the same values. For details, see the SIL report.

Basically, for safe opening you should connect two NC contacts in series, and for safe closing connect two NO contacts in parallel.

## 5.2 Safe output states

### Relay outputs

In the safe state, the relay is deactivated, that is, the working contact is open.

### Current output

The safe state here is the indication of an error state via output of the signal level specified for this in NE43.

## 5.3 Configuration

The configuration of the device must be performed exclusively using the control panel. Configuration through the device interface is not permitted for safety-relevant applications.

The functions set must be checked using suitable testing after configuration is complete.

**Example 1:** The power output is configured with a start value of 50 °C and a final value of 500 °C at 4 mA ... 20 mA (NE43) output characteristic, and the input is configured for a Pt100 type sensor.

By applying the corresponding input values (RTD simulator, decade resistor), it can be tested whether the output current at 50 °C is 4 mA and at 500 °C is 20 mA. The output current can be measured using, e. g., a measurement device (DMM).

### Example 2:

The input is configured for a type K thermocouple. The parameterisation of the relay output is: switching point of relay 1 at 1000 °C, high-temperature alarm (MAX) and mode of operation passive.

If input signals corresponding to, e. g., 500 °C and 1001 °C are applied, the switching of the relay can be tested by measuring the contact resistance.

After configuration, the settings must be protected from accidental changes by activating password protection.

## 5.4 Regular testing of function

The function of the device must be tested at the test intervals ( $T_{[proof]}$ ) specified in the SIL report. Tests as described in section 5.3 are suitable for this purpose.

## 5.5 Evaluation of the device outputs using subordinate control systems

As a premise for evaluation of equipment for safety functions, the settings of the power output characteristic must be set to 4 mA ... 20 mA (NE43).

The system which evaluates error states must correspondingly be configured to use NE43 specifications regarding the signal level.

## 5.6 Features not suitable for safety-relevant applications

### Configuration software

The configuration software is not part of the considerations for evaluation of safety functions of the device and may thus not be used to configure safety-relevant functions.

### User-defined characteristic

The user-defined characteristic consists of a linearisation table created in the configuration software (PACT<sup>ware</sup>™), which must be loaded into the configuration software of the device.

Since the device may not be configured using the configuration software (see section 5.3), the "user-defined characteristic" feature may not be used for safety-relevant applications.

### **Maintain in case of error**

The function "Maintain in case of error" could lead to a failure to signal fault states through the outputs, so that they are not detected. It is also possible that the specified safe state would not be entered.

### **Trend function**

The trend function is used for estimation of future behaviour of a value. The trend is measured periodically and represented as a linear increase between the two measurement points. This approximate representation is only suitable for certain applications and is therefore not considered for the safety technology evaluation.

### **Simulation current and relay simulation**

The simulation mode of the device is an aid for commissioning which simulates the presence of a certain output signal which can then be evaluated by a general control layer.

In this mode, the outputs are independent of the input values, thus there is no signal transfer between sensors connected and the outputs.

Thus the device is not in a normal operating state. For this feature, therefore, no safety evaluations have been performed and as a result, it may not be used for a safety-related application.

## **5.7 Firmware versions in combination with the safety function**

One factor in the consideration of use of the KF\*\*-(Ex)1.D for safety functions is the operational reliability of the devices.

This was determined for the supplied firmware at version 1.09 or better. Thus the safety evaluation is valid for versions 1.09, 1.14, 1.38, 1.42.

### 6 Mounting and connection

#### 6.1 Installation



Attention

*The temperature converters KF\*\*-GUT-(Ex)1.D comply with protection class IP20 and therefore must be protected in case of inappropriate ambient conditions (water, small foreign bodies).*

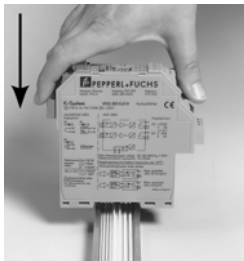

The devices of the Pepperl+Fuchs K systems and also the temperature converters KF\*\*-GUT-(Ex)1.D can be fitted to a 35 mm DIN rail according to DIN EN 50022. Simply snap the devices **vertically**; avoid tilting/sloping.

Additional mounting options, e.g. using the Power Rail, can be found in the Pepperl+Fuchs "DIN-Rail Housing" catalog or in the "CD-ROM catalog".

Measurements of  
KF\*\*GUT-(Ex)1.D

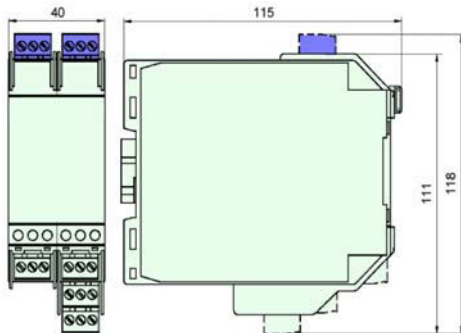

## 6.2 Connection

The removable terminals of the KF series simplify considerably the connection and the switch cabinet installation. They allow a quick and fault-free replacement of devices in case of a service event.

Terminals are equipped with screws, are self-opening, have a large connection area for a wire cross-section of up to 2.5 mm<sup>2</sup> and coded plugs, making it impossible to mix them up.

The intrinsically safe field circuit is connected to the **blue** terminals 1 ... 6 of KF\*\*GUT-(Ex)1.D and may be guided into the potentially explosive area using connector cables in accordance with DIN EN 60079-14.

The non-intrinsically safe field circuit is connected to the **green** terminals 1 ... 6 of KF\*\*GUT-(Ex)1.D.

Terminal 5 remains always free on the GUT.



You can connect:

- an RTD Pt100, Pt500, Pt1000, Ni100 or Ni1000 in accordance with DIN IEC 60751
  - in 2-wire technology (terminals 2 and 3)
  - in 3-wire technology (terminals 1 ... 3)
  - in 4-wire technology (terminals 1 ... 4)
- a thermocouple of the type B, E, K, J, L, N, R, S, T in accordance with DIN IEC 60584-1 (terminals 1 and 2)
  - Using the parameterisation software **PACTware™**, it is also possible to enter an individual characteristic for a special thermocouple.
  - For internal cold junction compensation, terminal K-CJC is required instead of the normal terminals 1 ... 3.
  - You can also connect a second redundant thermocouple of the same type (terminals 2 and 6; cold junction compensation with the same value as for the couple on terminals 1 and 2; as for the function, see section 8.2.4).
- a potentiometer (800 Ω ... 20 kΩ)
  - in 2-wire technology (terminals 2 and 3)
  - in 3-wire technology (terminals 2, 3, 6)
  - in 5-wire technology (terminals 1 ... 4 and 6)
- a voltage signal source
  - -100 mV ... +100 mV
  - 0 ... 1 V
  - 0 ... 10 V
  - 2 ... 10 V

(Terminals 2 and 6)

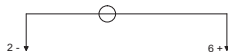
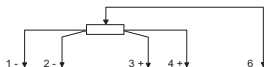
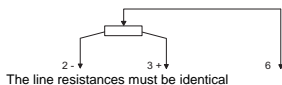
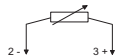
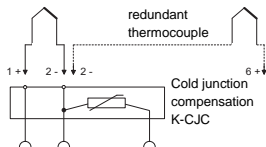
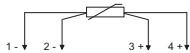
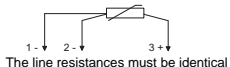
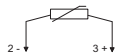

The remaining green terminals provide the following functions:

- Terminals 7/8: current output (9 free)
- Terminals 10 ... 12: relay 1
- Terminals 16 ... 18: relay 2
- Terminals 23/24: power supply (22 free)

Terminals 13 ... 15 and 19 ... 21 do not exist for GUT.

As for the power supply via Power Rail, please refer to the Pepperl+Fuchs "DIN-Rail Housing" catalog or the "CD-ROM" catalog.

As for the exact terminal assignments, please also refer to the data sheet.

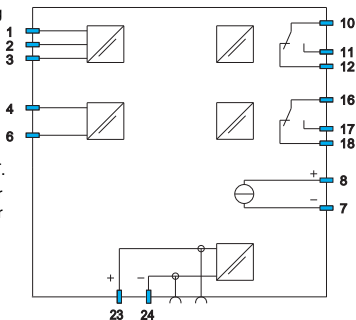

### 6.3 GUT front side

The following elements can be found on the GUT front side:

- LED ERR (red) for display of
  - a sensor fault (flashes red)
  - of a device malfunction (continuously red)
- Green PWR LED to indicate the presence of the supply voltage
- LED OUT 1 (yellow) to indicate relay 1 active
- LED OUT 2 (yellow) to indicate relay 2 active
- a display to show measurement values and malfunctions and for display in the parameter setting mode
- four keys for the parameterisation of the GUT
  - ▲ (Up)      ▼ (Down)      ESC (Escape)      OK
- Interface for connecting a computer for parameterization and diagnostics of the device with the **PACT<sup>ware</sup>**™ operating software, using the K-ADP-USB adapter

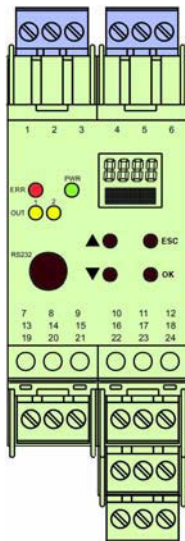

## 7 Display mode and error signals

The current measurement value is displayed in the selected unit in the normal mode. As for the selection of the unit, see section 8.3.

If a fault occurs which can be detected by the GUT, one of the following messages is displayed until the fault is cleared:

- *Err INT* in case of an internal GUT error; please contact Pepperl+Fuchs
- *Err MEM* in case of an error in the GUT memory; please contact Pepperl+Fuchs
- *Err SB* in case of a sensor breakage (only for the sensor types RTD and TC); if the redundant thermocouple function has been selected (see section 8.2.3), a sensor breakage may also trigger the message *Err DV RED* (see below)
- *Err SC* in case of a sensor short-circuit (only for RTD sensor type)
- *Err CJC* if the internal cold junction compensation has been selected (see section 8.2.3) and a breakage or short circuit has occurred within the K-CJC terminal
- *Err SB RED* if the redundant thermocouple function has been selected (see section 8.2.3) and a sensor breakage has occurred in the second thermocouple
- *Err RED* if the redundant thermocouple function has been selected (see section 8.2.3) and a sensor breakage has occurred for both thermocouples
- *Err DV RED* (for "deviation from redundant TC"), if the redundant thermocouple function has been selected, two thermocouples are connected and the tolerated deviation is exceeded between the two couples is exceeded (see section 8.2.3 and section 8.2.4)

Be aware that the error signals *Err SB*, *Err SC*, *Err SB RED* and *Err RED* refer to the sensor function and not to the sensor lines.

Due to the principle, the following line faults are detected:

- for 2-wire technology
  - lead breakage on terminals 2 and 3
  - short circuit between terminals 2 and 3
- for 3-wire technology
  - lead breakage on terminals 2 and 3
  - short circuit between terminals 2 and 3
- for 4-wire technology
  - lead breakage on terminals 2 and 4
  - short circuit between terminals 2 and 3
  - short circuit between terminals 2 and 4
  - short circuit between terminals 1 and 3
  - short circuit between terminals 1 and 4

In case of a fault, the relays normally switch to the idle state. Exceptions are described in section 8.2.4 and section 8.5.1 (Maintain in case of error).

The behaviour of the current output in case of a fault is described in section 8.2.4 and section 8.6.2.

## 8 Editing device data



Warning

*A change in device data will change the operation of the device!  
Before entering new data into the device, you should therefore ascertain that no danger to the installation will result.*



Note

*In this manual, the parameterisation of the device via the control panel is described. Parameterisation by means of a PC is more convenient.  
The necessary K-ADP-USB can be ordered from Pepperl+Fuchs. The **PACTware™** operating software and the manual are available on our Internet page [www.pepperl-fuchs.com](http://www.pepperl-fuchs.com) under Software > PACTware.*

*Some specialised functions can only be selected using **PACTware™**, for instance, pulse suppression as an alternative to the start-up override.*

### 8.1 Parameterisation mode control panel

#### 8.1.1 Invocation

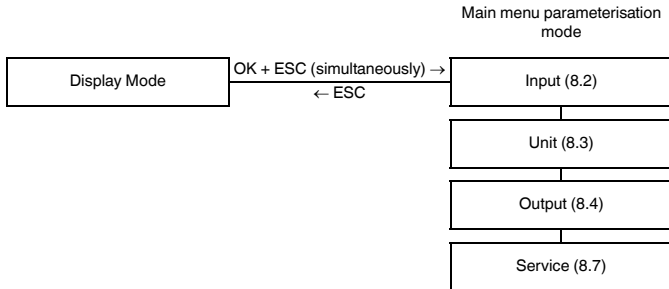

By pressing the ESC key (perhaps several times), you can return to the display mode from every menu item of the parameterisation mode. If 10 minutes elapse without a key being pressed in parameterisation mode, the device switches automatically back to display mode.

### 8.1.2 Password

You can use a password to protect the parameterisation from unauthorised modifications (see section 8.7; inactive in the GUT default setting).

If the password protection is active, the various settings performed in the parameterisation mode may be viewed before the password entry; however, modifications are not possible in this way. The first time an attempt is made to modify a setting, the device automatically displays a window for entering the password.

After **each** transition from the display mode to the parameterisation mode, the password must be entered **once**.

The password cannot be modified and is **1234**.

To enter the password:

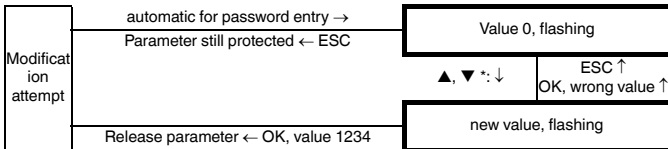

\*The value changes stepwise when actuating the ▲ or ▼ key. When you hold down the ▲ or ▼ key, the setting "scrolls" to higher or lower values.

### 8.1.3 Navigation principle

The illustration below describes the principle of navigation in the parameterisation mode using the ▲, ▼, OK and ESC key:

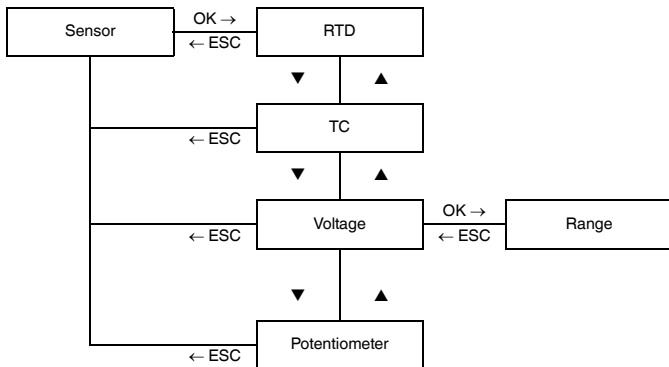

#### 8.1.4 Lowest menu level: select values, enter numbers

On the lowest menu level, you can either select between certain possible values for the individual parameters or enter a numerical value.

Proceed as follows:

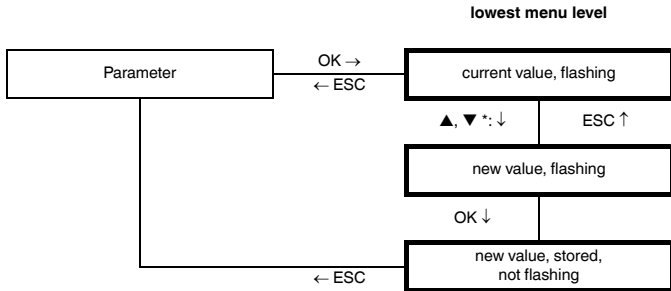

When entering **numeric values**, please note:

- If you press the ▲ or ▼ key, the value changes stepwise.
- If you hold the ▲ or ▼ key for a longer time, the value "rolls" to higher or lower values.
- The sign switches automatically.

## 8.2 Input

The illustrations below show the input parameter menus. Menu items of the lowest menu level are displayed in a bold frame.

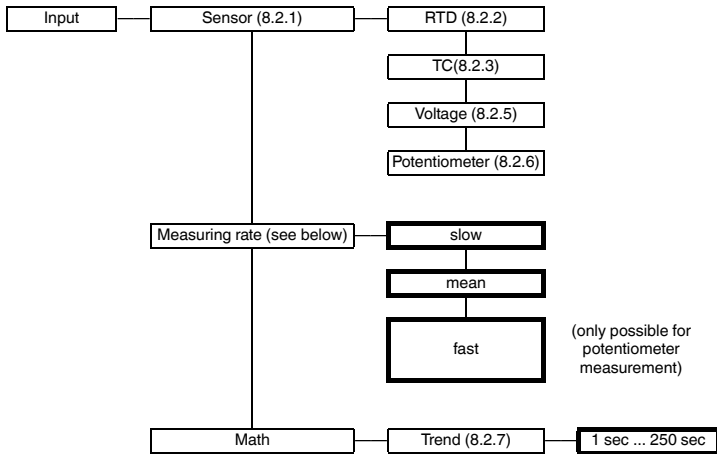

The precision values indicated in the data sheet refer to the **mean Measuring rate**. If the measuring rate is *fast*, the GUT measures more frequently, whereas the *slow* measuring rate delivers more precise results. The fast measuring rate is only possible for the potentiometer measurement.

### 8.2.1 Selecting the sensor Type

The selected sensor type (RTD, TC, voltage or potentiometer) is marked with *On*.



Attention

*In case of a sensor type change, the remaining parameters are reset to the default settings (see section 8.8). All entries you have ever made in parameter assignment mode will be lost.*

To select another sensor type, press the ▲ and ▼ keys to call it up. Next, press the OK key twice. After the first OK, you can press the ESC key to cancel.

### 8.2.2 RTD

The illustrations below show menu levels subordinate to the *RTD* menu item. Menu items of the lowest menu level are displayed in a bold frame. Menu items displayed only under certain circumstances are grayed out.

If the *RTD* sensor type has been selected (*On*) and you press the OK key, the program guides you from the menu item *RTD* to the menu item *Type*. If you select again the *RTD* sensor type (see section 8.2.1) and press the OK key twice, the *Type* menu item is available at once.

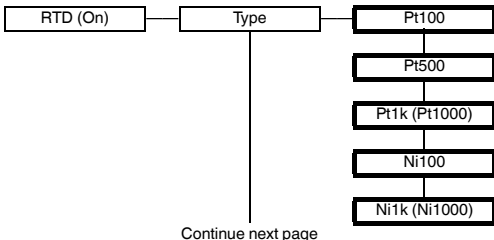

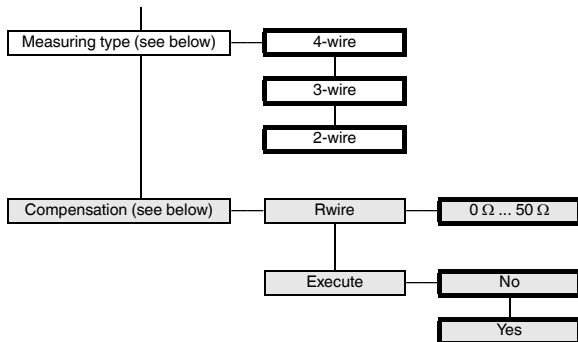

As for the terminal assignment for different **measuring types**, refer to the information provided in see section 6.2.

The **Compensation** menu option is only displayed if you have selected the measuring type *2-wire*. If *Execute* has been selected and *Yes* flashes while the OK key is pressed, the GUT automatically determines the line resistance.



Attention

*To ensure that the GUT can perform the automatic equalisation, a jumper must be inserted on the sensor!*

### 8.2.3 Thermocoupler (TC)

The illustrations below show menu levels subordinate to the *TC* menu item. Menu items of the lowest menu level are displayed in a bold frame.

If the *TC* sensor type has been selected (*On*) and you press the OK key, the program guides you from the *TC* menu item to the *Type* menu item. If you select again the *TC* sensor type (see section 8.2.1) and press the OK key twice, the *Type* menu item is available at once.

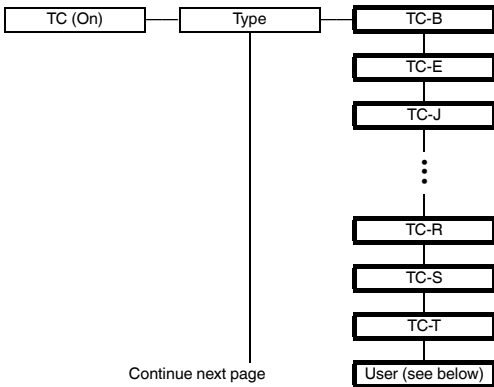

Continue next page

By means of the Pepperl+Fuchs **PACT<sup>ware</sup>**™ parameterisation software, it is possible to enter an individual characteristic for a special thermocouple. Afterwards, you can select this characteristic via **User**.

The representation is shifted to the left compared to the previous page.

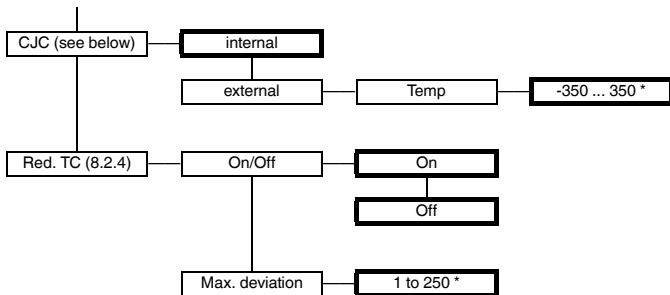

\* in the selected unit, such as °C (see section 8.3)

**CJC:** The selected compensation type (*internal* or *external*) is marked with *On*. To select another compensation type, first call it up using the ▲ and ▼ keys. Next, press the OK key twice. After the first OK you can press the ESC key to cancel.

For an internal cold junction compensation, you require the terminal K-CJC (see section 6.2) instead of the normal terminal 1 ... 3 as an accessory.

If the *External* compensation type has been selected (*On*) and you press the OK key, the program guides you from the *External* menu item to the *Temp* menu item. If you select again the *External* compensation type (see above) and press the OK key twice, the menu item *Temp* is available at once. Enter the external reference temperature here.

### 8.2.4 Behaviour with redundant thermocoupler (TC)

If *Red. TC* → *On/Off* → *On* has been selected, the GUT behaves as follows:

- If the specified tolerated deviation (*max. deviation*) is exceeded between the two thermocouples,
  - the error signal *Err DV RED* is output (see section 7)
  - a relay with the error signal function drops out (see section 8.5.4)
  - a relay with the trip value function (see section 8.5.1) as well as the current output still use the measured value of the first thermocouple (terminals 1 and 2, see section 6.2) as an input signal
  - the current output does not output any fault current
- If a breakage of one of the two thermocouples has been detected,
  - the error signal *Err SB* or *Err SB Red* is output (see section 7)
  - a relay with the error signal function drops out (see section 8.5.4)
  - a relay with the trip value function (see section 8.5.1) and the current output use the measured value of the non-dropped out thermocouple as an input signal
  - the current output does not output any fault current
- If a breakage of both thermocouples is detected,
  - the error signal *Err Red* is output (see section 7)
  - a relay with the error signal function drops out (see section 8.5.4)
  - a relay with the trip value function (see section 8.5.1) also drops out unless the *Maintain in case of error* function has been selected (see section 8.5.1)
  - the current output outputs the selected fault current (see section 8.6.2)

### 8.2.5 Voltage

The illustration below shows the menu levels subordinate to the *Voltage* menu item. Menu items of the lowest menu level are displayed in a bold frame.

If the *Voltage* sensor type has been selected (*On*) and you press the OK key, the program guides you from the *Voltage* menu item to the *Range* menu item. If you select again the *Voltage* sensor type (see section 8.2.1) and press the OK key twice, the *Range* menu item is available at once.

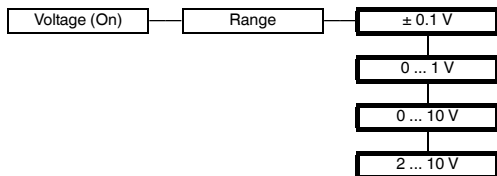

### 8.2.6 Potentiometer

The illustration below shows the menu levels subordinate to the *Potentiometer* menu item. Menu items of the lowest menu level are displayed in a bold frame. Menu items displayed only under certain circumstances are grayed out.

If the *Potentiometer* sensor type has been selected (*On*) and you press the OK key, the program guides you from the *Potentiometer* menu item to the *Measuring type* menu item. If you select again the *Potentiometer* sensor type (see section 8.2.1) and press the OK key twice, the *Measuring type* menu item is available at once.

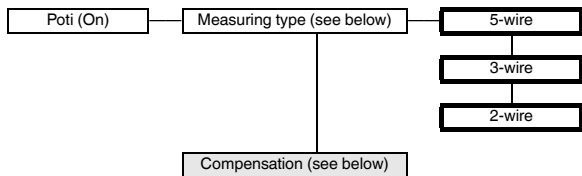

As for the terminal assignment for different **measuring types**, compare with the information in section 6.2. The **Compensation** menu option is only displayed if you have selected the measuring type *2-wire*. The parameterisation options for the compensation of the sensor type *Potentiometer* are identical with those of the sensor type *RTD*. As for the description, refer to section 8.2.2.

### 8.2.7 Trend

Instead of the measured value, it is also possible to use the modification of the measured value per time unit as a basis for a limit monitoring or for the output on a current output. For this purpose, the *Trend* parameter requires the input of the length  $\Delta t$  of a time interval (see section 8.2).

The following rule applies if the *assignment* selected for a relay (see section 8.5.1) or current output is (see section 8.6) *Trend*,

- the GUT determines a measured value  $\vartheta_1$
- waits until the specified time elapses  $\Delta t$ ,
- determines a measured value  $\vartheta_2$  and
- calculates the value  $(\vartheta_2 - \vartheta_1)/\Delta t$

The value  $(\vartheta_2 - \vartheta_1)/\Delta t$  is then used as an input signal for limit monitoring or for the current output.

Select a sufficiently high value for  $\Delta t$  to ensure that temperature fluctuations relevant for your application which might occur during this time cannot cause any problem. This means that not only insignificant measured value fluctuations must be tolerated. Select a sufficiently low value for  $\Delta t$  to ensure that relevant minimum and maximum measured values are not hidden.

#### Application examples:

- An alarm is triggered if the temperature rises by more than 10 °C per second.
- Display of the temperature modification per unit of time (or processing in the process control system/ in the control) by means of the proportional current signal

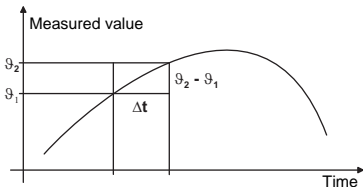

### 8.3 Unit

The illustration below describes the menu of the unit. Menu items of the lowest menu level are displayed in a bold frame. Menu items displayed only under certain circumstances are grayed out.

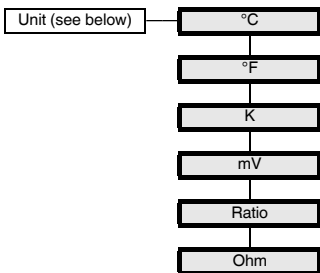

The **unit** is used for measured-value display and for all corresponding settings in the parameterisation mode. The selection of the sensor type determines which units are available (see section 8.2.1). In some cases, the selected measuring type is also relevant (see section 8.2.6):

- for RTD and TC: °C, °F, K
- for voltage: mV
- for potentiometer, 5-wire: Ratio,  $\Omega$
- for potentiometer, 3-wire: Ratio
- for potentiometer, 2-wire:  $\Omega$

## 8.4 Output

The illustrations below show the output parameter menus.

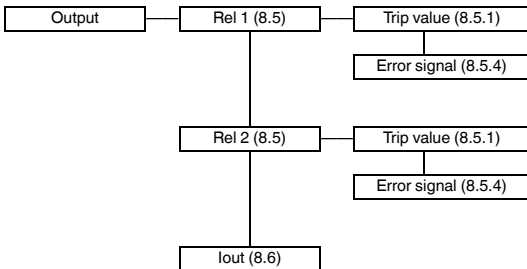

## 8.5 Relays

Via the *Rel 1* and *Rel 2* menu items, you can press the OK key to open a menu in which you can enter individual parameters for the selected relay. The two menu structures are completely identical and therefore are only described once.

The activated function of a relay (*trip value* or *alarm indication*) is marked with *On*. To enable another function, first call it up using the ▲ and ▼ keys. Next, press the OK key twice. After the first OK you can press the ESC key to cancel.

### 8.5.1 Trip value

The illustrations below show menu levels subordinate to the *Trip value* menu item. Menu items of the lowest menu level are displayed in a bold frame.

If the *Trip value* function has been enabled (*On*) and you press the OK key, the program guides you from the *Trip value* menu item to the *Assignment* menu item. If you reactivate the *Trip value* function (see section 8.5) and press the OK key twice, the *Assignment* menu item is available.

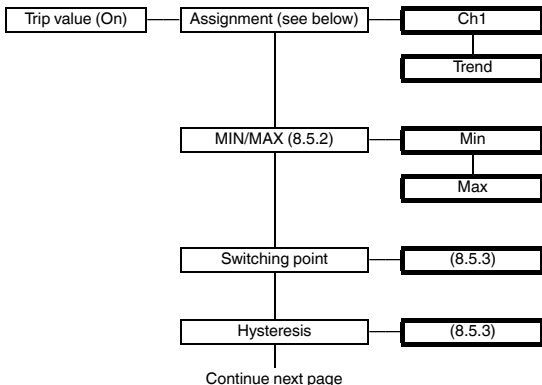

If you select the **assignment** *Ch1*, the limit monitoring refers to the measured value of the GUT. This is the "normal" selection.

If you select the **assignment** *Trend*, the limit monitoring refers to the modification of the measured value per time unit. For more details, refer to section 8.2.7.

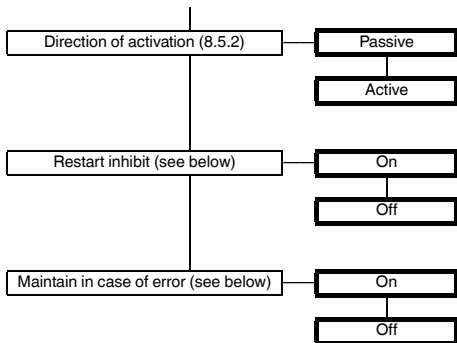

The **Restart inhibit** helps you to avoid that short-term trip value overranges are not noticed by the operating staff.

If *Restart inhibit On* has been selected, the new state is maintained after the relay switching until the ESC key is pressed or the device is restarted. These actions reset the relay, except for a limit violation.

Via the **Maintain in case of error** function, you can avoid that the relay drops out in case of a fault (see section 6).

If *Maintain in case of error On* has been selected, the relay state is maintained in case of a fault until the corresponding signal is cleared. Afterwards, the relay recovers its normal function.

### 8.5.2 Operating behaviour of the relays

*Max* or *Min* can be specified as switching direction; *Active* or *Passive* can be activated as direction of activation (see section 8.5.1). Range of application:

- Switching direction *Max*, direction of activation *Active*: Alarm in case of a limit overrange, e.g. horn ON; overheat protection, e.g. cooling ON
- Switching direction *Max*, direction of activation *Passive*: Overheat protection, e.g. heating OFF; Min/Max operation in case of high hysteresis, e.g. heating ON/OFF
- Switching direction *Min*, direction of activation *Active*: Alarm in case of a limit underrange, e.g. horn ON; undercooling protection, e.g. heating ON
- Switching direction *Min*, direction of activation *Passive*: undercooling protection, e.g. cooling OFF; Min/Max operation in case of high hysteresis, e.g. cooling ON/OFF

The illustration below describes the GUT operating behaviour:

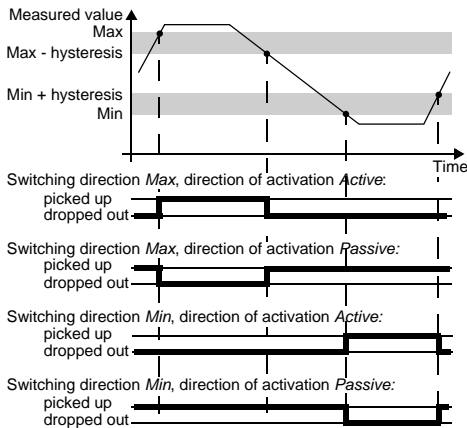

### 8.5.3 Switching point and hysteresis

Be aware of the following when entering the switching point and hysteresis values:

- The following rule applies if the *assignment Ch1* has been selected (see section 8.5.1):
  - Both values must be specified in the unit selected under *Unit* (see section 8.3).
  - The input limits of the switch point depend on the measuring range of the selected sensor (see section 8.9).
- The following rule applies if the *assignment Trend* has been selected (see section 8.5.1):
  - Both values must be specified as unit/sec. (e.g. °C/sec).
  - For all units except for mV, you can select a switching point between -100 unit/sec and +99.00 unit/sec ; for mV, you can select a value in the range from -10.0 mV/sec to +9.900 mV/sec.
- The hysteresis value must be high enough to avoid flickering of the relays (reference value: > 1 % of the measuring range).
- As illustrated in the representation of the switching behaviour in section 8.5.2, the *Max* switching direction requires that the switch point hysteresis value  $\geq$  is the switch point lower limit. With the *Min* switching direction, the value must be the switch point + hysteresis  $\leq$  switch point upper limit. These limitations are automatically specified by the GUT.

### 8.5.4 Error signal

The illustration below shows two menu levels subordinate to the *Error signal* menu item. Menu items of the lowest menu level are displayed in a bold frame.

If the *Error signal* function has been enabled (*On*) and you press the OK key, the program guides you from the *Error signal* menu item to the *Restart inhibit* menu item. If you reactivate the *Error signal* function (see section 8.5) and press the OK key twice, the *Restart inhibit* menu item is available.

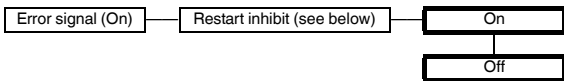

A relay with the **Error signal** function is picked up in the normal mode. If the device detects a fault (see section 6), the relay drops out.

The **Restart inhibit** avoids that short-term faults are not noticed by the operating staff.

If *Restart inhibit On* has been selected, the new state is maintained after the relay dropout until the ESC key is pressed or the device is restarted. These actions reset the relay unless the fault still exists.

## 8.6 Current output

The illustrations below show menu levels subordinate to the *Lout* menu item. Menu items of the lowest menu level are displayed in a bold frame.

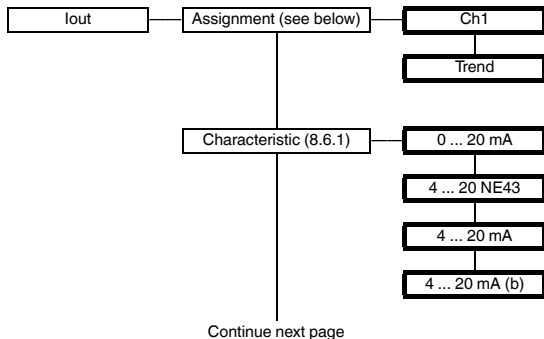

If you select the **assignment** *Ch1*, the output on the current output is proportional to the measured value of the GUT. This is the "normal" selection.

If you select the **assignment** *Trend*, the current output is proportional to the modification of the measured value per time unit. For more details, refer to section 8.2.7.

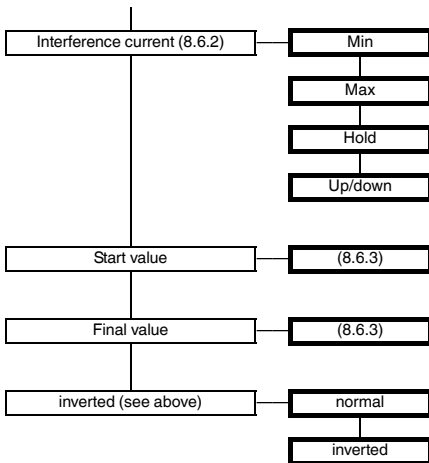

If you select the **inverted** characteristic, the representation of the start value and the final value is inverted (see section 8.6.1).

### 8.6.1 Characteristic

The various settings have the following significance (as for the setting of the start/end value, refer to see section 8.6.3):

#### Setting 0 ... 20 mA

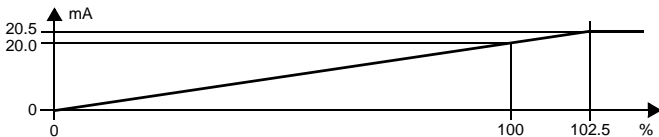

For this setting, the start value is converted to 0 mA and the final value to 20 mA. Intermediate values are converted proportionally.

Values less than the start value cannot be evaluated (output 0 mA). With values greater than the end value, the output current increases linearly to maximally 20.5 mA (102.5 % of the measuring range). Additional overranges cannot be evaluated (output 20.5 mA).

#### Setting 4 ... 20 NE43

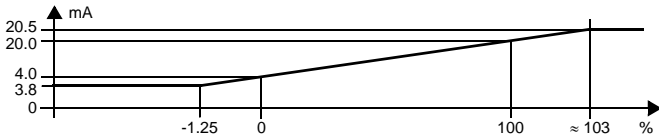

For this setting, the initial value is converted to 4 mA and the final value to 20 mA. Intermediate values are converted proportionally.

In case of a start value underrange, the output current falls linearly to a minimum of 3.8 mA (-1.25 % of the measuring range). Additional underranges cannot be evaluated (output 3.8 mA). If the actual value exceeds the final value, the output current increases linearly to a maximum of 20.5 mA (about 103 % of the measurement range). Additional overranges cannot be evaluated (output 20.5 mA).

#### Setting 4 -20 mA

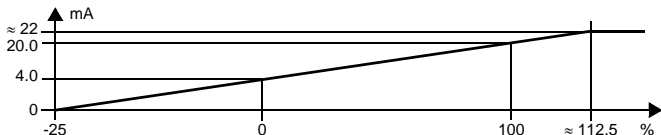

For this setting, the initial value is converted to 4 mA and the final value to 20 mA. Intermediate values are converted proportionally.

For values less than the start value, the output current decreases linearly to 0 mA (-25 % of the measuring range). Additional underranges cannot be evaluated (output 0 mA). If the final value is exceeded, the output current increases linearly up to approx. 22 mA (approx. 112.5 % of the measuring range). Further overranges cannot be evaluated (output approx. 22 mA).

#### Setting 4 -20 mA (b)

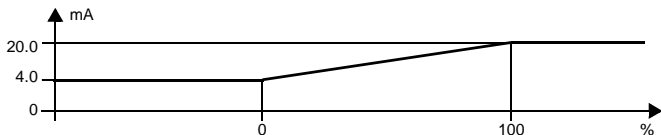

For this setting, the initial value is converted to 4 mA and the final value to 20 mA. Intermediate values are converted proportionally.

A start value underrange cannot be evaluated (output 4 mA). An overrange of the final value also cannot be evaluated (output 20 mA) (b = limited).

### 8.6.2 Interference current

The following table shows what the result of the current output is depending on the setting in the event of a malfunction:

Setting	Current path characteristic 0 ... 20 mA	Characteristics 4 ... 20 NE43, 4 ... 20 mA (b)	Characteristic 4 ... 20 mA
Min	0 mA (cannot be distinguished from the measurement of the start value)	2.0 mA	0 mA (cannot be distinguished from an underrange of the start value)
Max	approx. 21.5 mA	approx. 21.5 mA	approx. 22 mA (cannot be distinguished from a final value overrange)
hold	last measured value before fault occurred		
Up/down only useful for RTD	0 mA for <i>Err SB</i> (cannot be distinguished from a measurement of the start value)  approx. 21.5 mA for <i>Err SC</i>	2.0 mA for <i>Err SB</i>  approx. 21.5 mA for <i>Err SC</i>	0 mA for <i>Err SB</i> (cannot be distinguished from an underrange of the start value)  approx. 22 mA for <i>Err SC</i> (cannot be distinguished from an overrange of the final value)

The current output behaviour in case of the various alarm indications regarding a redundant thermocoupler is described in section 8.2.4.

### 8.6.3 Start value and final value

Be aware of the following when entering the start value and the final value:

- The following rule applies if the *assignment Ch1* has been selected (see section 8.6):
  - Both values must be specified in the unit selected under *Unit* (see section 8.3).
  - The input limits depend on the maximum measuring range of the selected sensor (see section 8.9). The difference between the final value and the start value must be at least 1 % of the start value (automatically predefined by the GUT).
- The following rule applies if the *assignment Trend* has been selected (see section 8.6):
  - Both values must be specified as unit/sec. (e.g. °C/sec).
  - For all units except for mV, the start value can be selected from -100 unit/sec to +99.00 unit/sec; for mV it can be selected from -10.0 mV/sec to +9.900 mV/sec. A final value in the range between the start value + 1% and +100.0 unit/sec or +10.00 mV/sec can be selected.

## 8.7 Service

The illustration below shows the service parameter menus. Menu items of the lowest menu level are displayed in a bold frame.

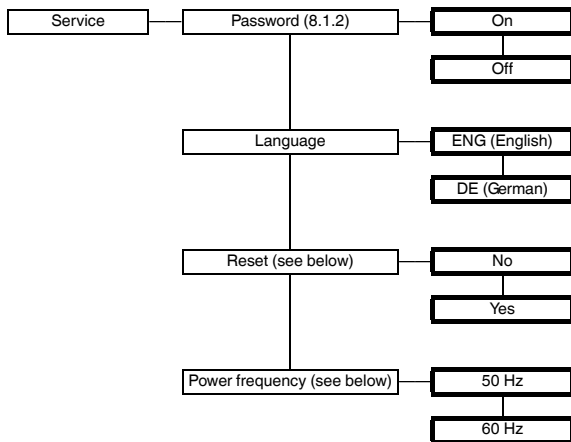

**Reset:** If Yes flashes and you press the OK key, the GUT settings are reset to the factory settings except for the sensor type (see section 8.8, for the selection of the sensor type see section 8.2.1). All inputs (except for the sensor type) which you have been performed in the parameterisation mode at any time are lost.

**Power frequency:** Specify the frequency of the supply network here. This approach is the best method to avoid that this power frequency affects the GUT (also important for DC devices).

## 8.8 Default settings

### Sensor type RTD

Parameter	Default settings	User settings
Type	Pt100	
Measuring type	3-wire	
Unit	°C	

### Sensor type TC

Parameter	Default settings	User settings
Type	TC-K	
CJC	Internal	
Red. TC	Off	
Unit	°C	

### Sensor type voltage

Parameter	Default settings	User settings
<i>Range</i>	<i>0 ... 10 V</i>	
<i>Unit</i>	<i>V</i>	

### Sensor type potentiometer

Parameter	Default settings	User settings
<i>Measuring type</i>	<i>3-wire</i>	
<i>Unit</i>	<i>Ratio</i>	

### Input remaining parameters

Parameter	Default settings	User settings
<i>Measuring rate</i>	<i>medium</i>	
<i>Math Trend</i>	<i>2 sec</i>	

**Parameter relay 1 and 2**

Parameter	Default settings	Individual setting relay 1	Individual setting relay 2
<i>Trip value</i>	<i>On</i> (= selected)		
<i>Assignment</i>	<i>Ch1</i>		
<i>MIN/MAX</i> (= switching direction)	<i>Min</i>		
<i>Switching point</i>	Start value sensor measuring range		
<i>Hysteresis</i>	Sensor measuring range		
<i>Mode of operation</i>	<i>Active</i>		
<i>Restart inhibit</i>	<i>Off</i>		
<i>Maintain in case of error</i>	<i>Off</i>		
<i>Error message</i>	Not selected		

### Parameter current output

Parameter	Default settings	User settings
<i>Assignment</i>	<i>Ch1</i>	
<i>Characteristic</i>	<i>4 ... 20 NE43</i>	
<i>Error current</i>	<i>Max</i>	
<i>Start value</i>	Start value sensor measuring range	
<i>Final value</i>	Final value sensor measuring range	
<i>Inverted</i>	<i>Normal</i>	

### Parameter service

Parameter	Default settings	User settings
<i>Password</i>	<i>Off</i>	
<i>Language</i>	ENG (= English)	
<i>Reset</i>	<i>No</i>	
<i>Power frequency</i>	<i>50 Hz</i>	

## 8.9 Measuring ranges of the sensors

Sensor	Start value	Final value
<i>Pt100, Pt500, Pt1000</i>	-200 °C	850 °C
<i>Ni100, Ni1000</i>	-60 °C	235 °C
<i>TC B</i>	100 °C	1800 °C
<i>TC E</i>	-114 °C	1000 °C
<i>TC J</i>	-210 °C	1200 °C
<i>TC K</i>	-118 °C	1300 °C
<i>TC L</i>	-200 °C	900 °C
<i>TC N</i>	-118 °C	1300 °C
<i>TC R</i>	-22 °C	1600 °C
<i>TC S</i>	-22 °C	1600 °C
<i>TC T</i>	-270 °C	400 °C
<i>Voltage</i>	refer to range selection in section 8.2.5	
<i>Potentiometer</i>	0.00 Ω 0.00 ratio	20.00 kΩ 100.00 Ratio





# PROCESS AUTOMATION – PROTECTING YOUR PROCESS



## Worldwide Headquarters

Pepperl+Fuchs GmbH  
68307 Mannheim · Germany  
Tel. +49 621 776-0  
E-Mail: [info@de.pepperl-fuchs.com](mailto:info@de.pepperl-fuchs.com)

For the Pepperl+Fuchs representative  
closest to you check [www.pepperl-fuchs.com/contact](http://www.pepperl-fuchs.com/contact)

[www.pepperl-fuchs.com](http://www.pepperl-fuchs.com)

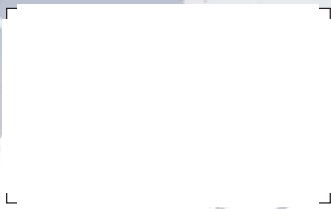

 **PEPPERL+FUCHS**  
*PROTECTING YOUR PROCESS*



# SCATTERGOOD & JOHNSON LTD

ELECTRICAL ENGINEERING & FLUID CONTROL DISTRIBUTORS

Est.1899

At Scattergood & Johnson Ltd, we pride ourselves on being a technical distributor to specialist industries.

Working with a range of quality product suppliers across a number of specialist markets, we are not your average 'box shifter' - we are your technical and supply chain partner.

We fully support every product we sell - for free! Our internal team and external sales engineers can answer any product or application question, no matter the complexity.

Backing up this technical ability is a range of 50,000+ products available from stock for nationwide next day delivery (same day if required!), or you can collect what you need from any of our trade counters around the UK.

Select your specialist interest below to learn more about how we can help.

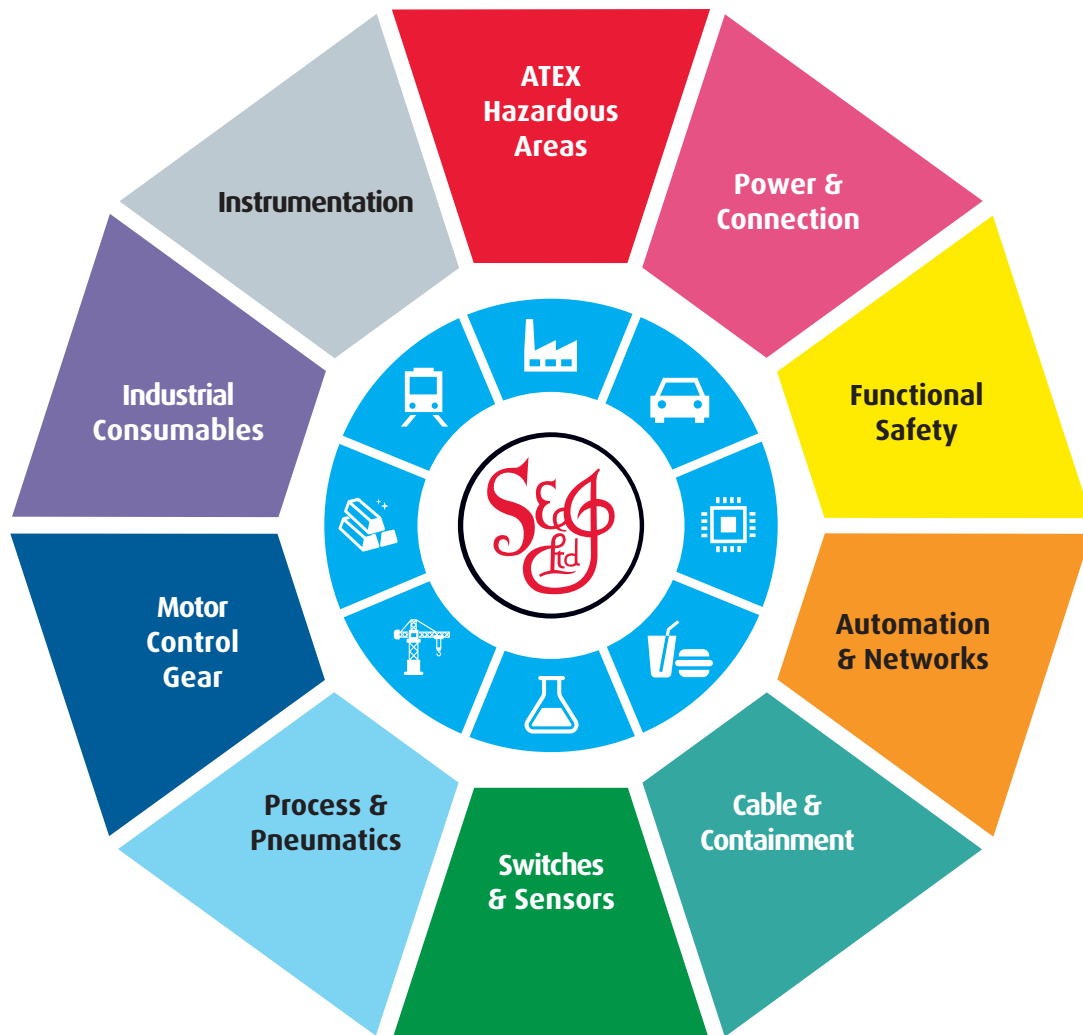

Online, In Branch and On the Road - Scattergood & Johnson Ltd, there when you need us.

# [www.scatts.co.uk](http://www.scatts.co.uk)