

MANUAL

HART Loop Converter KFD2-HLC-Ex1.D(**)

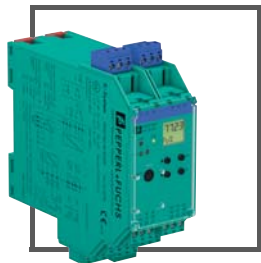

 **PEPPERL+FUCHS**
PROTECTING YOUR PROCESS

With regard to the supply of products, the current issue of the following document is applicable:

The General Terms of Delivery for Products and Services of the Electrical Industry,
published by the Central Association of the Electrical Industry
(Zentralverband Elektrotechnik und Elektroindustrie (ZVEI) e.V.) in its most recent version
as well as the supplementary clause: "Expanded reservation of proprietorship"

1	Introduction	2
1.1	Manufacturer	2
1.2	Content of this Document	2
1.3	Target Group, Personnel	3
1.4	Symbols Used	3
2	Product Specifications	5
2.1	Device Versions	5
2.2	Function	5
2.3	Assembly	6
2.4	Dimensions	8
3	Mounting and Installation	9
3.1	DIN Mounting Rail	9
3.2	Power Rail	10
3.3	Mounting	11
3.4	Connection	13
4	Configuration	25
4.1	Configuration via Software	25
4.2	Configuration via Keypad on the Device	26
5	Operation	52
5.1	Indicators during Operation	53
5.2	Fault Message	55
6	Dismounting, Maintenance, and Repair	56
7	Technical Specifications	59
7.1	Default Settings	59

1 Introduction

1.1 Manufacturer

Pepperl+Fuchs GmbH Lilienthalstraße 200, 68307 Mannheim, Germany Internet: www.pepperl-fuchs.com

1.2 Content of this Document

This document contains information that you need in order to use your product throughout the applicable stages of the product life cycle. These can include the following:

- Product identification
- Delivery, transport, and storage
- Mounting and installation
- Commissioning and operation
- Maintenance and repair
- Troubleshooting
- Dismounting
- Disposal



Note!

This document does not substitute the instruction manual.



Note!

For full information on the product, refer to the instruction manual and further documentation on the Internet at www.pepperl-fuchs.com.

The documentation consists of the following parts:

- Present document
- Instruction manual
- Datasheet

Additionally, the following parts may belong to the documentation, if applicable:

- EU-type examination certificate
- EU declaration of conformity
- Attestation of conformity
- Certificates
- Control drawings
- Additional documents

1.3 Target Group, Personnel

Responsibility for planning, assembly, commissioning, operation, maintenance, and dismantling lies with the plant operator.

Only appropriately trained and qualified personnel may carry out mounting, installation, commissioning, operation, maintenance, and dismantling of the product. The personnel must have read and understood the instruction manual and the further documentation.

Prior to using the product make yourself familiar with it. Read the document carefully.

1.4 Symbols Used

This document contains symbols for the identification of warning messages and of informative messages.

Warning Messages

You will find warning messages, whenever dangers may arise from your actions. It is mandatory that you observe these warning messages for your personal safety and in order to avoid property damage.

Depending on the risk level, the warning messages are displayed in descending order as follows:

***Danger!***

This symbol indicates an imminent danger.
Non-observance will result in personal injury or death.

***Warning!***

This symbol indicates a possible fault or danger.
Non-observance may cause personal injury or serious property damage.

***Caution!***

This symbol indicates a possible fault.
Non-observance could interrupt the device and any connected systems and plants, or result in their complete failure.

Informative Symbols***Note!***

This symbol brings important information to your attention.

**Action**

This symbol indicates a paragraph with instructions. You are prompted to perform an action or a sequence of actions.

2 Product Specifications

2.1 Device Versions

The following device versions described in this manual:

- HART Loop Converter KFD2-HLC-Ex1.D
- HART Loop Converter KFD2-HLC-Ex1.D.2W
- HART Loop Converter KFD2-HLC-Ex1.D.4S

2.2 Function

General

The HART Loop Converter is an isolated barrier suitable for intrinsically safe applications.

The device supplies field devices and can be connected in parallel to existing HART circuits.

The device analyzes up to four HART variables (PV, SV, TV, QV). Three HART variables can be transformed into varying current signals from these four HART variables. These signals are used to display the values via the analog inputs of the process control system.

The device is easily configured by the use of keypad or with the PACTware configuration software.

KFD2-HLC-Ex1.D.2W

In addition to the current outputs, the device has two changeover contacts. These changeover contacts can be programmed so that the changeover contacts function as limit values for the HART variables.

KFD2-HLC-Ex1.D.4S

In addition to the current outputs, the device has four NO contacts. These NO contacts can be programmed so that the NO contacts function as limit values for the HART variables.

2.3 Assembly

Operating and indicating elements

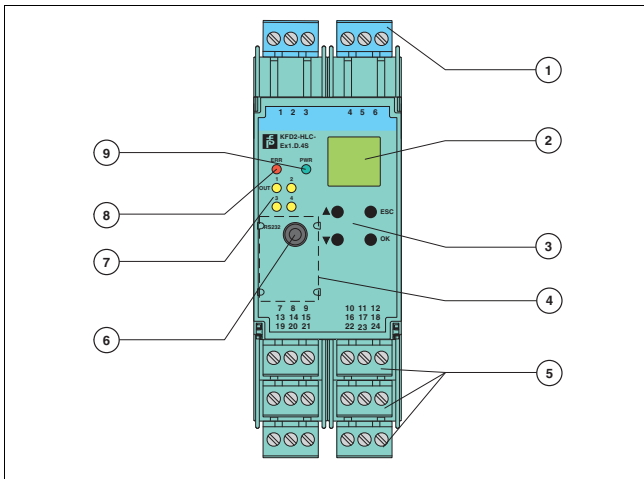

Figure 2.1 Example front view KFD2-HLC-Ex1D.4S

HART Loop Converter KFD2-HLC-EXT.D(1...)

Product Specifications

EN

1	Removable terminals, blue	
2	LC display	Display for showing <ul style="list-style-type: none"> the measured values the current output values the fault messages the parameterization mode
3	Keypad ▲ ▼ ESC OK	Four keys for selecting the displayed values, the current output values and for setting the parameters of the device Up Down Escape Confirmation
4	Place for labeling	
5	Removable terminals, green	
6	Programming socket	Interface for connecting a computer for parameterization and diagnostics of the device with the PACTware operating software, using the K-ADP-USB adapter
7	yellow LEDs	Outputs Out 1 to 4, indicating relay status
8	red LEDs	Indicating faults
9	green LEDs	Indicating power supply

2.4 Dimensions

Housing Type C2

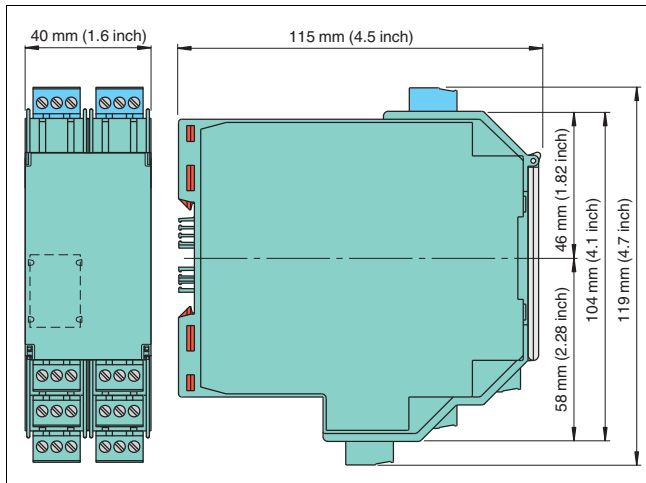

Figure 2.2

Number of terminal blocks max. 10

- Dimension drawing with screw terminals
- When using screw terminals with test sockets the device is 124 mm (4.9 inch) in height.
- When using spring terminals the device is 131 mm (5.16 inch) in height.

3 Mounting and Installation



Danger!

Explosion hazard from damaged electronic components

Premature wear of electronic components in a device that was previously used in a general electrical installation can cause sparks that can ignite the surrounding potentially explosive atmosphere.

Never install devices that have already been operated in general electrical installations in electrical installations used in combination with hazardous areas!



Danger!

Explosion hazard from pollution

An excessively polluted surface of the device can become conductive and consequently ignite a surrounding potentially explosive atmosphere.

Ensure that you install the device only in environments with a pollution degree 2 or better according to IEC/EN 60664-1.

3.1 DIN Mounting Rail

The devices are mounted on a 35 mm DIN mounting rail according to EN 60715.

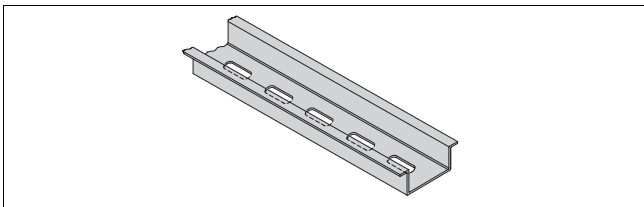

Figure 3.1 Example: DIN mounting rail UPR-MR (35 mm x 15 mm)

3.2 Power Rail

To reduce wiring and installation costs, Power Rail is the optimum solution. The Power Rail is a DIN mounting rail with plastic insert, that delivers power to the devices (24 V DC) and transfers bus signals and a collective error message.

The Power Rail is factory-equipped with cover and end caps. These parts cover empty and open segments of the Power Rail. Thus, the Power Rail is protected from contamination. Additionally the cover and end caps prevent that electrically conductive parts come in contact with the Power Rail.

Power Rail UPR-03

The Power Rail UPR-03 has 3 conductors.

- 2 conductors for power
- 1 conductor for collective error messaging

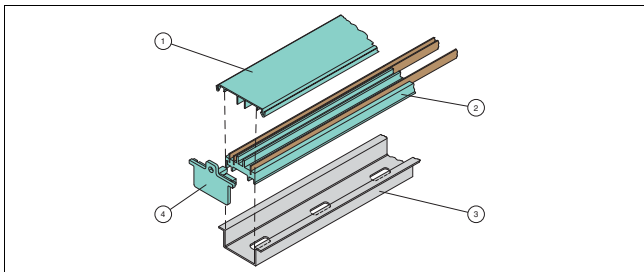

Figure 3.2 Example: Power Rail UPR-03

- 1 Cover UPR-COVER
- 2 Insert UPR-INS-03
- 3 DIN mounting rail UPR-MR (35 mm x 15 mm)
- 4 End cap UPR-E

3.3 Mounting



Danger!

Danger to life from electric shock

Absent or insufficient insulation can result in electric shock.

Only connect supplies that provide protection against electric shock to power feed modules (e. g. SELV or PELV).



Caution!

Property damage from use of isolators for Power Rail supply

Using the isolators for Power Rail supply can damage the isolators and make the Power Rail fail.

Do not supply the Power Rail via isolators.

Mounting in the Non-Hazardous Area



Mounting the Device

Snap the device onto the DIN mounting rail in a **vertical downward** movement.
See figure below.

Mounting in Areas that Require the Equipment Protection Level Gc



Danger!

Explosion hazard from live wiring of non-intrinsically safe circuits

If you connect or disconnect energized non-intrinsically safe circuits in a potentially explosive atmosphere, sparks can ignite the surrounding atmosphere.

Only connect or disconnect energized non-intrinsically safe circuits in the absence of a potentially explosive atmosphere.

**Danger!**

Explosion hazard from wrong mounting

The device safety can be impaired by external environmental influences and by mechanical stress. This can lead to sparking that can ignite a surrounding potentially explosive atmosphere.

Mount the device in a surrounding enclosure that complies with IEC/EN 60079-0 and that is rated with the degree of protection IP54 according to IEC/EN 60529.

**Mounting the Device**

Snap the device onto the DIN mounting rail in a **vertical downward** movement. See figure below.

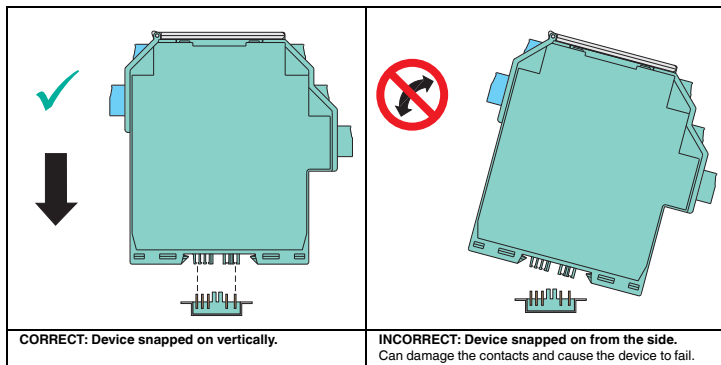

Figure 3.3



Mounting the Terminal Blocks

Connect the terminal blocks or disconnect the terminal blocks.

EN

3.4 Connection



Danger!

Danger to life from incorrect installation

Incorrect installation of cables and connection lines can compromise the function and the electrical safety of the device.

- Observe the permissible core cross section of the conductor.
- When using stranded conductors, crimp wire end ferrules on the conductor ends.
- Use only one conductor per terminal.
- When installing the conductors the insulation must reach up to the terminal.
- Observe the tightening torque of the terminal screws.



Danger!

Explosion hazard from live wiring of non-intrinsically safe circuits

If you connect or disconnect energized non-intrinsically safe circuits in a potentially explosive atmosphere, sparks can ignite the surrounding atmosphere.

Only connect or disconnect energized non-intrinsically safe circuits in the absence of a potentially explosive atmosphere.



Danger!

Explosion hazard from wrong separation distances

If you do not observe the minimum separation distances between intrinsically safe circuits of associated apparatus and non-intrinsically safe circuits, this can lead to added currents or voltages. This can result in a current/voltage flashover generating sparks. The sparks can ignite the surrounding potentially explosive atmosphere.

Ensure that you observe the compliance of the separation distances to all non-intrinsically safe circuits according to IEC/EN 60079-14.



Danger!

Danger to life from electric shock

Absent or insufficient insulation can result in electric shock.

- Maintain sufficient distance between the connection lines, terminals, housing, and the environment.
- Insulate connection lines, terminals, and the housing from the environment.



Danger!

Danger to life from electric shock

Absent or insufficient insulation can result in electric shock.

Only connect supplies that provide protection against electric shock (e. g. SELV or PELV).



Danger!

Danger to life from electric shock

Working on live parts at voltages higher than 50 V AC or 120 V DC can result in electric shock.

1. De-energize the device.
2. Secure the circuit against reconnection.
3. Verify that the device is de-energized at all poles.
4. Provide protection from adjacent live parts, if present.

The removable terminal blocks simplify connection and control cabinet construction significantly. These terminal blocks offer adequate space for the connection of leads with core cross-sections of up to 2.5 mm² (14 AWG). The terminal blocks are coded with red coding pins so misconnection of terminal blocks are eliminated.



Connecting Circuits

1. Connect the field circuit.
2. Connect the control circuit.

3.4.1 Input Connection (Field Circuit)



Danger!

Explosion hazard from wrong separation distances

If you do not observe the minimum separation distance between 2 intrinsically safe circuits, this can lead to added currents or voltages. This can result in a current/voltage flashover generating sparks. The sparks can ignite the surrounding potentially explosive atmosphere.

Ensure that you observe all separation distances between 2 adjacent intrinsically safe circuits according to IEC/EN 60079-14.



Connecting the Field Circuit

1. Connect the field circuit to the blue terminals.
2. Observe the tightening torque of the terminal screws. The tightening torque is 0.5 Nm to 0.6 Nm.

The intrinsically safe field circuit may be routed in the hazardous area with connection lines in accordance with DIN EN 60079-14. You can connect the following field devices:

1. any separately supplied HART current circuit with transmitter or positioner connected in parallel
Connection to terminals 2 and 3
2. a HART-capable active current source, e. g., a separately supplied HART measuring transmitter
Connection to terminals 2 and 3 with bridge between terminals 5 and 6
3. a 2-wire HART measuring transmitter, e. g., HART measuring transmitter with an analog output signal of 4 mA to 20 mA
The HART measuring transmitter is supplied by the isolated barrier
Connection to terminals 1 and 3 with bridge between terminals 4 and 5

HART Loop Converter KFD2-HLC-EX1.D (..)

Mounting and Installation

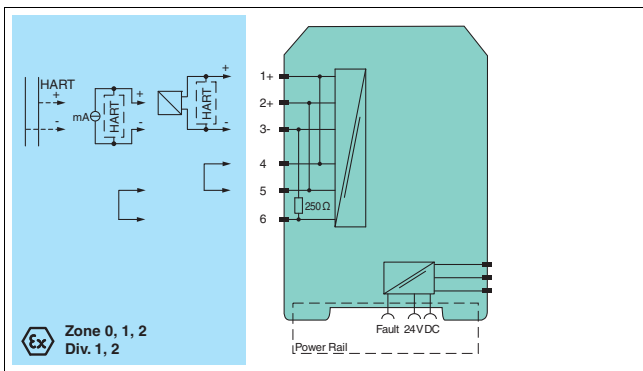

Figure 3.4

3.4.2 Output Connection (Control Circuit)

Connecting the Control Circuit

1. Connect the control circuit to the green terminals.
2. Note the tightening torque of the terminal screws. The tightening torque is 0.5 Nm to 0.6 Nm.

Connection KFD2-HLC-Ex1.D

The following connections are available:

- Terminals 7 to 9: output I, current output as source (7/8) or sink (7/9)
- Terminals 13 to 15: output II, current output as source (13/14) or sink (13/15)
- Terminals 19 to 21: output III, current output as source (19/20) or sink (19/21)
- Terminals 22/24: connection of HART handheld
- Terminals 23/24: power supply 24 VDC

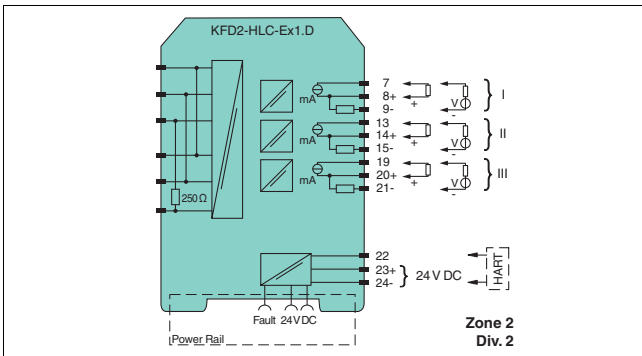

Figure 3.5

Connection KFD2-HLC-Ex1.D.2W



Danger!

Danger to life from electric shock

Working on live parts at voltages higher than 50 V AC or 120 V DC can result in electric shock.

1. De-energize the device.
2. Secure the circuit against reconnection.
3. Verify that the device is de-energized at all poles.
4. Provide protection from adjacent live parts, if present.

The following connections are available:

- Terminals 10 to 12: output I (relay 1 (change-over contact))
- Terminals 16 to 18: output II (relay 2 (change-over contact))
- Terminals 7 to 9: output III, current output as source (7/8) or sink (7/9)
- Terminals 13 to 15: output IV, current output as source (13/14) or sink (13/15)
- Terminals 19 to 21: output V, current output as source (19/20) or sink (19/21)
- Terminals 22/24: connection of HART handheld
- Terminals 23/24: power supply 24 VDC

EN

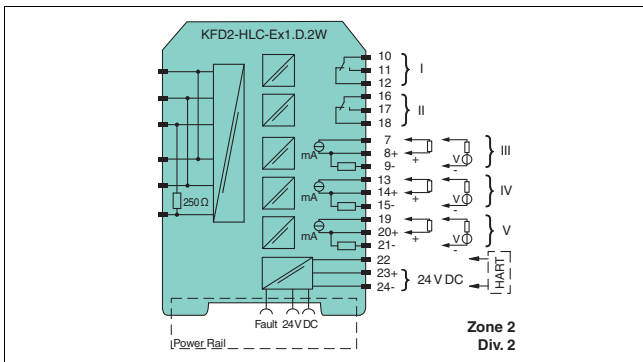

Figure 3.6

Connection KFD2-HLC-Ex1.D.4S



Danger!

Danger to life from electric shock

Working on live parts at voltages higher than 50 V AC or 120 V DC can result in electric shock.

1. De-energize the device.
2. Secure the circuit against reconnection.
3. Verify that the device is de-energized at all poles.
4. Provide protection from adjacent live parts, if present.

The following connections are available:

- Terminals 10/11: output I (relay 1 (NO contact))
- Terminals 11/12: output II (relay 2 (NO contact))
- Terminals 16/17: output III (relay 3 (NO contact))
- Terminals 17/18: output IV (relay 4 (NO contact))
- Terminals 7 to 9: output V, current output as source (7/8) or sink (7/9)
- Terminals 13 to 15: output VI, current output as source (13/14) or sink (13/15)
- Terminals 19 to 21: output VII, current output as source (19/20) or sink (19/21)
- Terminals 22/24: connection of HART handheld
- Terminals 23/24: power supply 24 VDC

EN

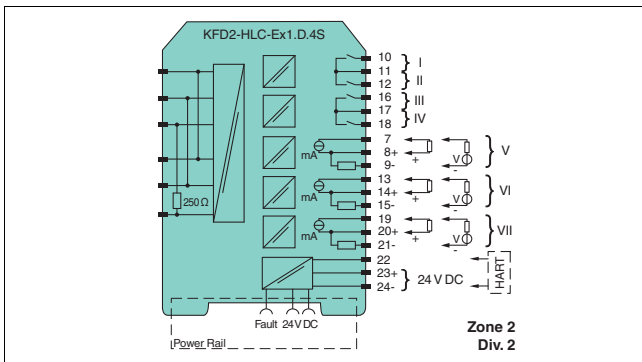

Figure 3.7

3.4.3 Connecting a HART Handheld to the Field Device

You have two options for connecting a HART handheld to the field device:

- Connection to terminals 22/24 of the isolated barrier, see chapter 3.4.2
- Connection to the field cables from the isolated barrier to the field device



Danger!

Risk of explosion

Danger of explosion when using a non-certified HART handheld in a hazardous area.

Use a HART handheld certified for use in hazardous areas if the field cables lead into a hazardous area.

Transmitting the HART signal using the current outputs of the isolated barrier is not possible.

3.4.4 Description of HART Operations

Dynamic Query of Variables

Universal HART command 3 is used to query dynamic variables from the field device. This query is done either directly or by activating burst mode.

Burst Mode

Burst mode is the preferred method because this mode guarantees the fastest signal transmission. The isolated barrier always tries to set the connected field device to burst mode. See chapter 4.2.6.

The command for burst mode activation is sent to the field device under the following conditions:

- after a restart or
- after resetting the isolated barrier after restarting the field device. In the process, communication between the field device and isolated barrier must have been reestablished again after a time-out.

Polling Mode (Command and Answer)

The isolated barrier deactivates the burst configuration of the field device. The isolated barrier performs the field device query using HART command 3. See chapter 4.2.6.

Procedure to Restore Burst Mode

If the isolated barrier does not receive any more data from the field device in burst mode, the following actions are taken:

- The isolated barrier switches to polling mode.
- The isolated barrier checks whether another HART master has started in the query signal circuit. If the isolated barrier has detected a HART master, the restoring of burst mode is interrupted.
- If the isolated barrier does not detect any other HART masters, the isolated barrier attempts to activate burst mode.
- As soon as the isolated barrier receives a burst message from the field device, the isolated barrier switches from polling mode to burst mode.

This process enables other HART masters to deactivate burst mode momentarily for service work.

Time-out (Communication Loss)

When the time-out time has been exceeded in the absence of communication, all outputs switch to the defined safe state. Time-out can be adjusted.

4 Configuration

4.1 Configuration via Software



Danger!

Explosion hazard from sparking when plugging or pulling the adapter

Plugging or pulling the adapter in a potentially explosive atmosphere can cause sparks that can ignite the surrounding atmosphere.

Only plug or pull the adapter in the absence of a potentially explosive atmosphere.



Caution!

Fault in the plant

Changing the device data changes the device function.

Before entering new device data, make sure the plant is not endangered by changing the device data.

The devices can be configured using the PACTware™ operating software.

Connection between Device and Computer

Connect the device and the computer using the K-ADP-USB adapter. This adapter can be ordered as an accessory.



Connecting the Device to the Computer via the USB Interface

1. Mount the device.
2. Connect the device to the power supply.
3. Connect the device to the PC via the adapter.
 - Connection on the device: front programming socket
 - Connection on the PC: USB interface
4. Refer to the "Installation and Configuration DTM Collection Conventional Interface Introduction" manual for further steps.

The operating software and the necessary device and communication DTMs can be downloaded from our internet page www.pepperl-fuchs.com (product search, enter PACTware). The manual "Installation and Configuration DTM Collection Conventional Interface Introduction" guides you through the installation steps necessary to install the software. The manual can be found on our internet page www.pepperl-fuchs.com (product search, enter PACTware).



Note!

The configuration and operation of the device via software is not described in this manual.

4.2 Configuration via Keypad on the Device



Danger!

Explosion hazard from sparking when using operating elements

Using operating elements in a potentially explosive atmosphere can cause sparks that can ignite the surrounding atmosphere.

Only use operating elements (e.g., switch, slider, button, etc.) in the absence of a potentially explosive atmosphere.



Caution!

Fault in the plant

Changing the device data changes the device function.

Before entering new device data, make sure the plant is not endangered by changing the device data.

Configuring the Device

Configure the device using the buttons on the front side. Use the **▲**, **▼**, **ESC**, and **OK** buttons for navigation. The following chapters contain more detailed information about the menus.

The navigation principle is shown using the following example:

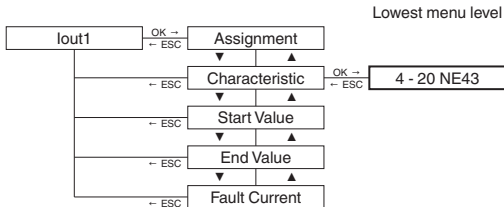

The menu items from the lowest menu level are outlined in bold.

4.2.1 Parameterization Mode

After being switched on, the device is in display mode. If you have password protection enabled, you must enter the password every time you transition from display mode to parameterization mode.

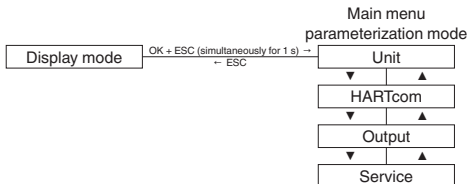

➤ Calling up Parameterization Mode

Press the **OK** and **ESC** buttons **simultaneously** for approx. 1 second.

↳ The device changes from display mode to parameterization mode.

➤ Exiting Parameterization Mode

1. Press the **ESC** once or multiple times. The number of times depends on which menu level you are in.

↳ The device changes from parameterization mode to display mode.

2. If you have not pressed a button for 10 minutes in parameterization mode, the device switches back automatically to display mode.

4.2.2 Password Protection

You can activate password protection to protect parameterization from unauthorized changes. If password protection is enabled, you can view the parameter settings but not change them. Password protection is deactivated during delivery. The password is preset and cannot be changed by the operator. The password is **1234**. Information about enabling password protection see chapter 4.2.9.



Entering the Password

1. As soon as you try to change the parameterization, the device switches automatically to the input window for password access.
 - ↳ The first digit of the password flashes.
2. Set the first digit of the password using the ▲ and ▼ buttons.
3. Confirm your entry with **OK**.
 - ↳ The next digit flashes.
4. Repeat steps 2 and 3, until all digits have been entered.
5. Confirm your entry with **OK**.
 - ↳ If the password was correct, the device changes to parameterization mode. The device can now be parameterized.
 - If the password was not correct, cancel password access and begin password entry again using step 1.



Canceling Password Entry

You can cancel password entry at any time.

Press the **ESC** button.

- ↳ The device switches to display mode.

4.2.3 Entering Numbers

At the lowest menu level of the **Parameter** menu, you have the option of selecting or entering a numerical value.

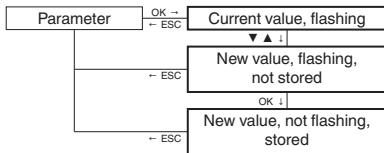

Selecting a Numerical Value

1. Select the parameter for which you want to change the numerical value.
2. Press the **OK** button.
 - ↳ The current value flashes.
3. Select a value from the list of values using the **▲** and **▼** buttons.
 - ↳ The new value flashes. The value is not stored.
4. Confirm your selection with **OK**.
 - ↳ The new value does not flash. The value is stored.

Entering a Numerical Value

1. Select the parameter where you want to enter the numerical value.
2. Press the **OK** button.
 - ↳ The current value flashes.
3. To change the value in steps, press the **▲** or **▼** button. **or**
 To change the value more quickly, press and hold the **▲** or **▼** button.
 - ↳ The new value flashes. The value is not stored.
4. Confirm your selection with **OK**.
 - ↳ The new value is stored.

4.2.4 Entering Floating Point Figures

At the lowest menu level of the **Parameter** menu, you have the option of entering floating point figures.

The floating point figures can have the following structure:

Positive number	Input	Negative number	Input
43210000	43.21 E06	-3210000	-3.21 E06
4321000	4321 E03	-321000	-321 E03
432100	432.1 E03	-32100	-32.1 E03
43210	43.21 E03	-3210	-3.21 E03
4321	4321 E00	-321	-321 E00
432.1	432.1 E00	-32.1	-32.1 E00
43.21	43.21 E00	-3.21	-3.21 E00
1.234	1.234 E00		
0.1234	123.4 E-03	-0.123	-123 E-03
0.01234	12.34 E-03	-0.0123	-12.3 E-03
0.001234	1.234 E-03	-0.00123	-1.23 E-03
0.0001234	123.4 E-06	-0.000123	-123 E-06

Table 4.1

For a floating point figure, you must enter the following parameters:

- four digits of the mantissa (decimals) for positive numbers
- a minus sign and three digits for the mantissa for negative numbers
- the position of the decimal point in or after the mantissa
- the exponents



Entering a Numerical Value

1. Select the parameter for which you want to enter the numerical value.
2. Press the **OK** button.
 - ↳ The current value from the mantissa and exponent flashes.
3. Press the **OK** button.
 - ↳ With positive numbers, the first digit of the mantissa flashes.
With negative numbers, the minus sign flashes.
4. To change the value in steps from 0 to 9, press the **▲** or **▼** button.
To enter a minus sign, press the **▼** button until the first digit is less than 0.
5. Confirm your selection with **OK**.
 - ↳ The next digit of the mantissa flashes.
6. Repeat steps 4 and 5, until all digits have been entered.
7. Confirm your entry with **OK**.
 - ↳ The position of the decimal point flashes.
8. Press the **▲** or **▼** button to specify the position of the decimal point.
9. Confirm your entry with **OK**.
 - ↳ The exponent flashes.
10. To specify the value of the exponent, press the **▲** or **▼** button. You can select the exponents from E-33 to E33 in increments of three.
11. Confirm your entry with **OK**.
 - ↳ The new value is stored.

4.2.5 Unit

At the lowest menu level of the **Unit** menu, you have the option of selecting the unit type for the HART variables.

- **auto**

The device displays the unit which is transferred from connected HART field devices for the HART variables PV, SV, TV, QV.

- **custom**

The device displays the unit which was defined by you for the HART variables PV, SV, TV, QV in the **Custom Tag** menu.

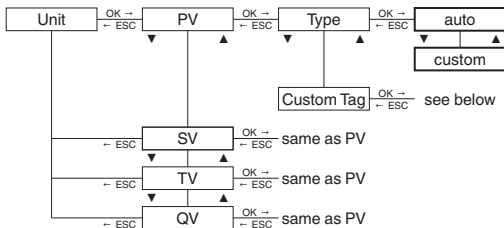

▶ Changing the Custom Tag of HART Variables

1. Select the HART variable for which you would like to change the **custom tag**.
2. Press the **OK** button.
3. Select the **Custom Tag** menu.
 - ↳ The device displays:
if a value has not been defined: the insert mark and the symbol ↵
if a value is defined: the insert mark on the first character, the following character, and the symbol ↵.
4. To select one of eight possible positions for the insert mark before the symbol ↵, press the ▲ or ▼ button.
5. Confirm your selection with **OK**.
 - ↳ The insert mark flashes.
6. To select a character, press the ▲ or ▼ button.
7. Confirm your entry with **OK**.
8. Repeat steps 4 and 7, until all characters have been entered. You can also define spaces.
9. To select the symbol ↵, press the ▲ or ▼ button.
10. Confirm your entry with **OK**.
 - ↳ The new value for **Custom Tag** has been stored.

▶ Canceling the Value Input for HART Variables

You can cancel the value entry at any time.
Press the **ESC** button.

4.2.6 HARTcom

The **HARTcom** menu offers the option of specifying the method for communication between device and field device. If available, the device activates burst mode of the HART field device for the fastest possible communication. To query variables (PV, SV, TV, QV, if present) the device uses the universal HART command 3.

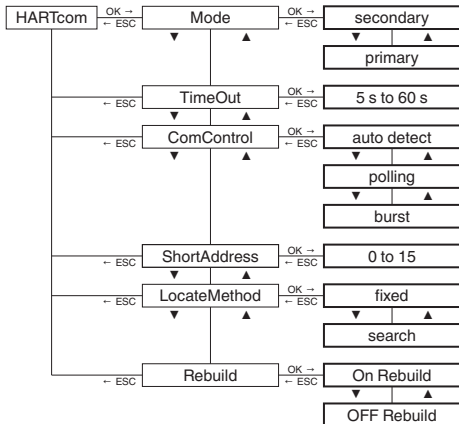

Selecting a Mode

The device functions as primary or secondary HART master according to the HART standard. The device is compatible with each HART handheld and for every other HART master.

1. Use the **▲** or **▼** buttons to select whether the device should operate as a primary or secondary HART master.
2. Confirm your selection with **OK**.

Defining TimeOut

If the device does not receive a valid HART message within the specified time, the **communication fault** message is output.

1. To change the time in steps, press the **▲** or **▼** buttons.
Set the time from 5 s to 60 s in increments of 5 seconds.
2. Confirm your entry with **OK**.

Defining ComControl

You can specify the communication type between isolated barrier and field device. The change in communication type is effective immediately. It is not necessary to restart the isolated barrier. See chapter 3.4.4.

1. Select the type of communication using the **▲** or **▼** buttons.
2. Select **auto detect**.
↳ If you select this type of communication, the burst configuration of the field device is not changed.
3. Choose **polling**.
↳ If you select this type of communication, the isolated barrier deactivates the burst configuration of the field device. The isolated barrier performs the field device query using HART command 3.
4. Choose **burst**.
↳ If you choose this type of communication, the isolated barrier activates the burst configuration of the field device for HART command 3.
5. Confirm your entry with **OK**.



Note!

Note that the field device can be put into burst mode, in accordance to the isolated barrier configuration. This also applies when a different HART master is in the HART circuit. If a different HART master changes the burst configuration of the field device, the isolated barrier waits until the other HART master logs out of the HART circuit. The isolated barrier assumes that the other HART master is logged off when it does not send a message for approximately 60 s. After this period of time, the isolated barrier activates the burst configuration of the field device.



Defining ShortAddress

The defined short address is needed for identification of the field device during the localization phase.

1. To enter a short address between 0 to 15, press the ▲ or ▼ buttons.
2. Confirm your entry with **OK**.



Selecting LocateMethod

According to the HART standard, more than one HART field device can be present in a HART circuit. But the device can communicate only with a single HART field device. This HART field device is identified during the localization phase.

1. Select the localization method with the ▲ or ▼ buttons.
2. Select **fixed**.
 - ↳ The device communicates with the field device that has a short address defined under **ShortAddress**.
3. Choose **search**.
 - ↳ During booting, the device searches for the field device with the smallest short address, beginning with the short address defined under **ShortAddress**. The address of the field device found is stored by the device under **ShortAddress**. This accelerates the device starting when it boots again.
4. Confirm your entry with **OK**.

▶ Activating Rebuild

If the connection to the field device has been lost, the localization phase can be performed with **Rebuild** without switching the device off and on again.

1. Select **On Rebuild** with the ▲ or ▼ buttons.
2. Confirm your selection with **OK**.
 - ↳ The display **On Rebuild** flashes.
3. Press the **OK** button.
 - ↳ The device searches for connected field devices when booting.
4. Press the **ESC** button once or multiple times to switch to display mode.

4.2.7 Current Outputs

In the **Output** menu, you have the option of defining current outputs 1 to 3 of the device. The menu structure is identical for the three current outputs. Current output 1 is described as an example. For information on relay contact outputs, see chapter 4.2.8.

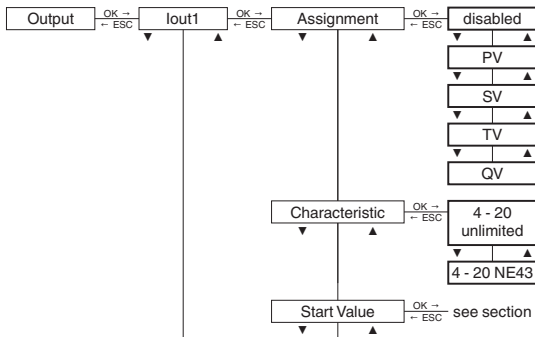

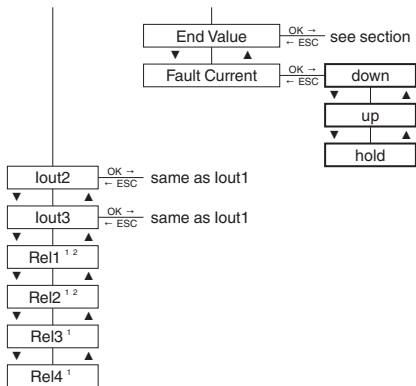

¹ Relay contact outputs for KFD2-HLC-Ex1.D.4S

² Relay contact outputs for KFD2-HLC-Ex1.D.2W

Selecting an Assignment

The values of the selected HART variable (PV, SV, TV, QV) are shown on the current output. The number of available variables depends on the HART field device. When selecting **disabled**, the downscale fault current of 0 mA or 2 mA is constantly present at the current output, depending on the characteristic.

1. Select the desired HART variable using the ▲ or ▼ buttons.
2. Confirm your selection with **OK**.

▶ Defining a Characteristic

The choice of characteristic defines the limits for measuring underrange and overrange. Measuring underranges or overranges outside the specified range cannot be analyzed. If measuring ranges are undercut or exceeded, the minimum or maximum value is issued constantly.

1. Select the characteristic using the ▲ or ▼ buttons.
2. Select the characteristic **4 - 20 unlimited**.
 - ↳ For the characteristic **4 - 20 unlimited**, measuring underranges are analyzed linearly up to 0 mA, and measuring overranges are analyzed linearly up to approx. 23 mA by the device.
3. Select the characteristic **4 - 20 NE43**.
 - ↳ For the characteristic **4 - 20 NE43**, measuring underranges are analyzed linearly up to 3.8 mA, and measuring overranges are analyzed linearly up to 20.5 mA by the device.
4. Confirm your entry with **OK**.

▶ Defining the Start Value

Make sure during configuration that the start value is at least 1% less than the end value. If the start value does not meet this requirement, the start value will not be accepted by the device.

1. Enter the start value as a floating point figure. For entering floating point figures, see chapter 4.2.4. The defined unit from the **Unit** menu is used as the unit. See chapter 4.2.5.
2. Confirm your entry with **OK**.

▶ Define the End Value

Make sure during configuration that the end value is at least 1 % greater than the start value.

1. Enter the end value as a floating point figure. For entering floating point figures, see chapter 4.2.4. The defined unit from the **Unit** menu is used as the unit. See chapter 4.2.5.
2. Confirm your entry with **OK**.

Example

Characteristic 4 - 20 NE43, start value 2 bar, end value 10 bar

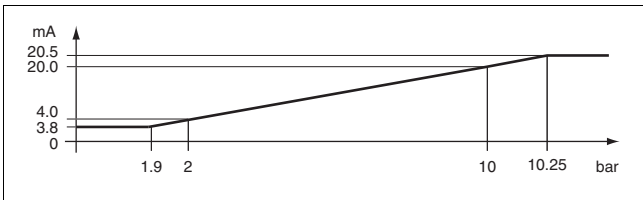

Figure 4.1

Defining the Fault Current (fault message)

The type of fault current chosen will define how the current output transmits the fault message to the controller.

1. Select the type of fault current using the ▲ or ▼ buttons.
2. Select the fault current **down**.
 - ↳ The fault message is indicated by a low current value.
3. Select the fault current **up**.
 - ↳ The fault message is indicated by a high current value.
4. Select the fault current **hold**.
 - ↳ The last measured value before the fault occurred is stored.
5. Confirm your entry with **OK**.

4.2.8 Relay Contact Outputs

In the **Output** menu, you have the option of defining relay contact outputs 1 to 4^{1 2} of the device. The menu structure of the four relay contact outputs is identical. Relay contact output 1 is described as an example. Information on the current outputs see chapter 4.2.7.

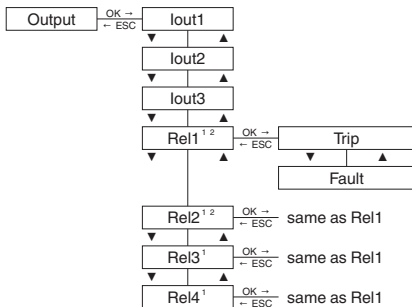

¹ Relay contact outputs for KFD2-HLC-Ex1.D.4S

² Relay contact outputs for KFD2-HLC-Ex1.D.2W



Selecting Relay Contact Output Menus

1. Select the desired relay contact output using the ▲ or ▼ buttons.
2. Confirm your entry with **OK**.
 - ↳ The relay contact output menus **Trip** and **Fault** are displayed. The active menu is marked as **On**.
3. If you would like to activate the other menu, select this menu with ▲ or ▼.
4. Press the **OK** button **twice**.
 - ↳ The active menu is marked as **On**. The submenu is displayed.
5. If you would like to cancel activation, press the **ESC** button after the first **OK**.

Limit Value (Trip)

Calling up a Limit Value

1. Select the **Trip** menu with the **▲** or **▼** buttons.
2. If the **Trip** menu is activated, press the **OK** button once.
↳ The **Assignment** submenu is displayed.
3. If the **Trip** menu is not activated, press the **OK** button twice.
↳ The **Assignment** submenu is displayed. The **Trip** menu is activated and is marked as **On**.

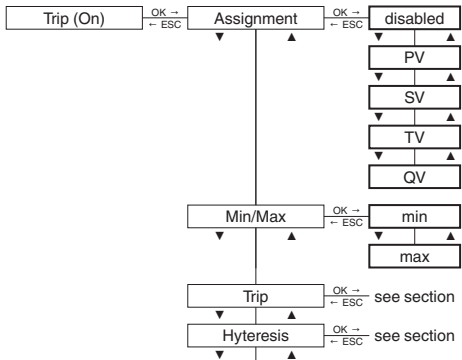

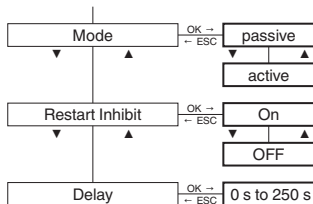

Selecting an Assignment

The values of the HART variables selected here (PV, SV, TV, QV) are monitored using a relay contact output. The number of available variables depends on the HART field device. When **disabled** is selected, the relay remains constant in a de-energized state.

1. Select the desired HART variable using the ▲ or ▼ buttons.
2. Confirm your selection with **OK**.

Defining Switching Characteristics

Selecting the switching characteristics defines the switching direction and the direction of operation. See applications.

1. Select the switching direction **min** or **max** with the ▲ or ▼ buttons.
2. Confirm your selection with **OK**.
3. Select the direction of operation **passive** or **active** with the ▲ or ▼ buttons.
4. Confirm your selection with **OK**.

You can implement the following applications:

- Switching direction **max**, direction of operation **active**: alarm if there is a limit value overrange, e. g., sounder on
- Switching direction **max**, direction of operation **passive**: switch off during limit value overrange, e. g., pump, heating, ... off, for larger hysteresis Min-Max operation (pump, heater, ... on/off)
- Switching direction **min**, direction of operation **active**: alarm if there is a limit value underrange, e. g., sounder is on.
- Switching direction **min**, direction of operation **passive**: switch off during limit value underrange, e. g., pump, heating, ... off, for larger hysteresis Min-Max operation (pump, heater, ... off/on)

The exact switching characteristics of the device are shown in the following illustration:

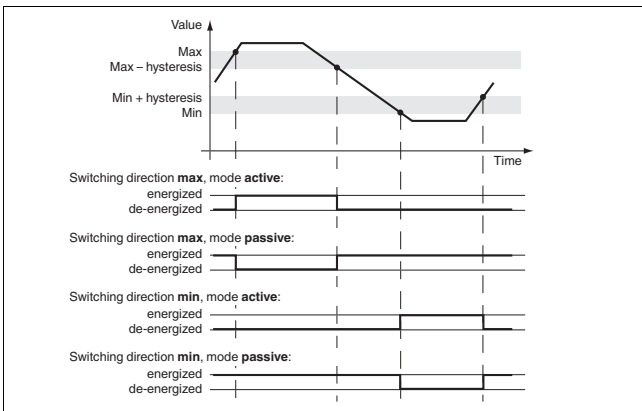

Figure 4.2

▶ Defining the Trip Point

1. Enter the starting point as a floating point figure. For entering floating point figures, see chapter 4.2.4. The defined unit from the **Unit** menu is used as the unit. See chapter 4.2.5.
2. Confirm your entry with **OK**.

▶ Defining Hysteresis

Make sure during input that the hysteresis is at least 1 % greater than the trip point. This avoids "fluttering" of the relay.

1. Enter the hysteresis as a floating point figure. For entering floating point figures, see chapter 4.2.4. The defined unit from the **Unit** menu is used as the unit. See chapter 4.2.5.
2. Confirm your entry with **OK**.

▶ Activating the Restart Inhibit

The restart inhibit is used to prevent momentary limit value violations from not being noticed by operating personnel.

1. Use the **▲** or **▼** buttons to select **On**.
2. Confirm your selection with **OK**.
 - ↳ The relay status is retained after switching the relay.
3. If you would like to reset the relay status, press the **ESC** or button or restart the device.
 - ↳ The relay is reset. Exception: there is a limit value violation.

▶ Defining the Response Delay

Inputting a response delay > 0 s prevents momentary limit value violations from triggering an alarm.

1. To change the time in steps, press the **▲** or **▼** buttons. Set the time from 0 s to 250 s in increments of 5 seconds.
2. Confirm your entry with **OK**.

Response delay has the following effects:

- When the value of the trip point is out of range (exceeded or not reached) for a period of time longer than the delay time, the relay switches.
- When the value of the trip point \pm hysteresis is in range (not reached or exceeded) for a period of time longer than the delay time, the relay switches back.
- Shorter overranges/underranges do not have an effect.

The following illustration shows an example of switching characteristics with response delay

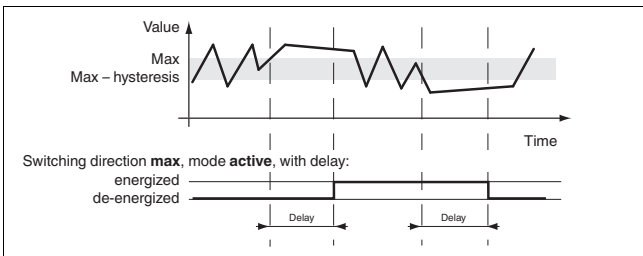
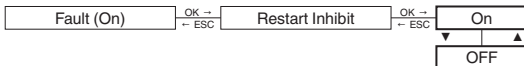

Figure 4.3

Fault Message

Calling up a Fault Message

1. Use the ▲ or ▼ buttons to select the **Fault message** menu.
2. If the fault message menu is activated, press the **OK** button once.
↳ The **Restart inhibit** submenu is displayed.
3. If the fault message menu is not activated, press the **OK** button twice.
↳ The **Restart inhibit** submenu is displayed. The **Fault message** menu is activated and is marked as **On**.



Activating the Restart Inhibit

The restart inhibit is used to prevent momentary limit value violations from not being noticed by operating personnel.

1. Use the ▲ or ▼ buttons to select **On**.
2. Confirm your selection with **OK**.
↳ The relay status is retained after switching the relay.
3. If you would like to reset the relay status, press the **ESC** or button or restart the device.
↳ The relay is reset. Exception: there is a fault message.

4.2.9 Service

In the **Service** menu, you have the option of specifying basic device parameters.

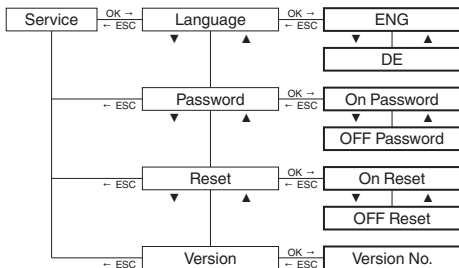

Select language

1. Use the ▲ or ▼ buttons to select which language is used by the device display.
2. Select **ENG** for English.
3. Confirm your selection with **OK**.
4. Select **DE** for German.
5. Confirm your selection with **OK**.

▶ Activating Password Protection

To protect parameterization from unauthorized changes, you can enable password protection. Information about password protection see chapter 4.2.2.

1. Use the ▲ or ▼ buttons to select the desired setting.
2. To enable password protection, select **On Password**.
3. Confirm your selection with **OK**.
4. To disable password protection, select **Off Password**.
5. Confirm your selection with **OK**.

▶ Resetting the Device to Factory Settings

1. Use the ▲ or ▼ buttons to select **On Reset**.
↳ **On Reset** flashes.
2. Confirm your selection with **OK**.
↳ The device is reset to factory settings. All entries you have defined in parameterization mode will be lost.

▶ Displaying the Software Version

Use the ▲ or ▼ buttons to display the version.

↳ The software version of the device software is displayed.

5 Operation



Danger!

Explosion hazard from live wiring of non-intrinsically safe circuits

If you connect or disconnect energized non-intrinsically safe circuits in a potentially explosive atmosphere, sparks can ignite the surrounding atmosphere.

Only connect or disconnect energized non-intrinsically safe circuits in the absence of a potentially explosive atmosphere.



Danger!

Explosion hazard from sparking when using operating elements

Using operating elements in a potentially explosive atmosphere can cause sparks that can ignite the surrounding atmosphere.

Only use operating elements (e.g., switch, slider, button, etc.) in the absence of a potentially explosive atmosphere.

5.1 Indicators during Operation

The isolated barrier displays the following operating modes and fault messages during operation.

Status Indicators

LED	Status	Description
Green LED	Off	No power supply
	Flashes regularly	Start-up phase, self-test
	On	Normal function
Red LED	Flashes briefly	Displays a single HART fault message received by the field device
	Flashes regularly	Invalid HART data (missing communication or fault in the field device)
	On	Device self-test of isolated barrier detected a fault
	On	Isolated barrier is in reset state, all other LEDs are off
Yellow LEDs	On	For KFD2-HLC-Ex1.D.2W and KFD2-HLC-Ex1D.4S: <ul style="list-style-type: none"> • Output Out 1, relay energized • Output Out 2, relay energized For KFD2-HLC-Ex1D.4S: <ul style="list-style-type: none"> • Output Out 3, relay energized • Output Out 4, relay energized

Table 5.1

Display Indicators

In normal operation, the display shows:

- the current values of the HART variables PV, SV, TV, QV in the selected unit
- the present current output values for the three current outputs in mA
- the current device status

This display shows information about the device status of the field device (1 byte) and about the response code (1 byte) of the field device. These two bytes are displayed in the first line of the display in hexadecimal form with the code RC on the left side.

- the current setting of the type of communication
 - LOOP Locate
The isolated barrier reestablishes the HART circuit. The isolated barrier performs the field device query using the HART command 3.
 - LOOP Poll
The isolated barrier performs the field device query using the HART command 3.
 - LOOP Burst
The isolated barrier receives the HART command 3 of the field device.
 - LOOP Mixed
The isolated barrier performs the field device query using the HART command 3 (polling). The field device is in burst mode, however it references a different HART command than 3.

In the event of a fault, the display shows:

- Err Device Fault
Displays a device fault in the isolated barrier – red LED lights up.
- Err Communication
Displays a communication fault – red LED flashes.
- Err Field Device Malfunction
Displays a field device failure – red LED flashes.

Display Options for Current Output Values and HART Variables

- To select the displayed measured values or current output values, use the ▲ and ▼ buttons.
- To select units for measured values, use the **Unit** menu. See chapter 4.2.5.
- Every time the isolated barrier receives a HART command 3 message from the field device, the display is updated.
- The isolated barrier displays the current output values as a four-digit number. The decimal point is set to provide the best possible resolution.
- The isolated barrier shows the floating point value for HART variables as follows:
 - If possible, as a four-digit number with decimal point and without exponent. Negative values are shown on the device with three digits because of the minus sign.
 - A digit is rounded as necessary. For example, the number 0.3456 is shown as 0.346.
 - If the isolated barrier cannot show the floating point value, the mantissa and exponent are shown in alternation.

5.2 Fault Message

The following table shows which fault message the current outputs send to the controller, based on the characteristic.

Setting	4 - 20 unlimited	4 - 20 NE43
down	0 mA Cannot be distinguished from falling below the start value	2.0 mA
up	approx. 23 mA Cannot be distinguished from the end value being exceeded	21.5 mA
hold	Last measured value before the fault	

Table 5.2

6 Dismounting, Maintenance, and Repair



Danger!

Explosion hazard from live wiring of circuits

If you connect or disconnect energized circuits in a potentially explosive atmosphere, sparks can ignite the surrounding atmosphere.

Only connect or disconnect energized circuits in the absence of a potentially explosive atmosphere.



Danger!

Danger to life from electric shock

Working on live parts at voltages higher than 50 V AC or 120 V DC can result in electric shock.

1. De-energize the device.
2. Secure the circuit against reconnection.
3. Verify that the device is de-energized at all poles.
4. Provide protection from adjacent live parts, if present.



Danger!

Danger to life from using damaged or repaired devices.

Using a defective or repaired device can compromise its function and its electrical safety.

- Do not use a damaged or polluted device.
- The device must not be repaired, changed or manipulated.
- If there is a defect, always replace the device with an original device from Pepperl+Fuchs.



Disconnecting Circuits

1. Disconnect the field circuit.
2. Disconnect the control circuit.
3. Disconnect the power supply.



Removing the Device

Use for dismantling of the device a slotted screwdriver

1. Insert the screwdriver (4) into the groove of the red mounting slider (3).
2. Turn the screwdriver (4) in the groove until the red mounting slider (3) springs back.
3. Repeat these steps on the other side of the device.
4. Remove the device (2) from the DIN mounting rail (1).

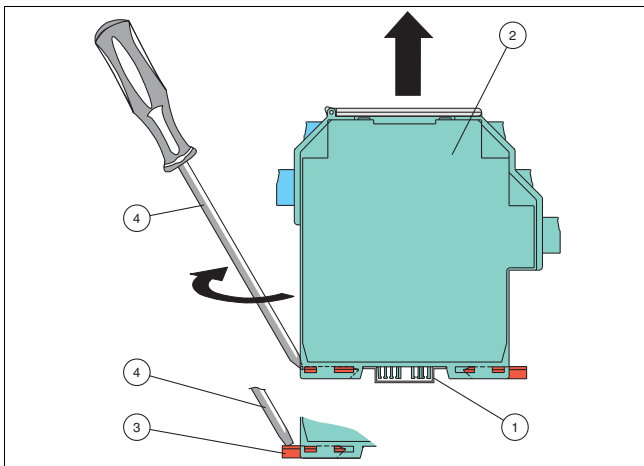

Figure 6.1 Dismounting of the device from the DIN mounting rail

- 1 35 mm DIN mounting rail
- 2 Device
- 3 Mounting slider
- 4 Slotted screwdriver

7 Technical Specifications

7.1 Default Settings

The following table provides an overview of the default settings. Information about resetting the device to the default setting see chapter 4.2.9.



Tip

If the device parameters have changed, enter these changes in the "Custom Value" column. This provides an overview of your individual device settings.

Menu	Parameters	Default setting	Custom value
Unit	PV → Type	auto	
	SV → Type	auto	
	TV → Type	auto	
	QV → Type	auto	
HARTcom	Mode	secondary	
	TimeOut	10 s	
	ComControl	auto detect	
	ShortAddress	0	
	LocateMethod	search	
Output → Iout1	Assignment	disabled	
	Characteristic	4 - 20 NE43	
	Start value	0.000	
	End value	100.0	
	Fault current	down	
Output → Iout2	Assignment	disabled	
	Characteristic	4 - 20 NE43	
	Start value	0.000	
	End value	100.0	
	Fault current	down	

Menu	Parameters	Default setting	Custom value
Output → Iout3	Assignment	disabled	
	Characteristic	4 - 20 NE43	
	Start value	0.000	
	End value	100.0	
	Fault current	down	
Output → Rel1 ^{1 2}	Limit value (Trip)	On (selected)	
	Limit value → Assignment	disabled	
	Limit value → Min/Max	min	
	Limit value → Trip point	80.00	
	Limit value → Hysteresis	10.00	
	Limit value → Operating mode	passive	
	Limit value → Restart inhibit	OFF	
	Limit value → Response delay	0 s	
	Fault message	not selected	
Output → Rel2 ^{1 2}	Limit value (Trip)	On (selected)	
	Limit value → Assignment	disabled	
	Limit value → Min/Max	min	
	Limit value → Trip point	80.00	
	Limit value → Hysteresis	10.00	
	Limit value → Operating mode	passive	
	Limit value → Restart inhibit	OFF	
	Limit value → Response delay	0 s	
	Fault message	not selected	

Menu	Parameters	Default setting	Custom value
Output → Rel3 ¹	Limit value (Trip)	On (selected)	
	Limit value → Assignment	disabled	
	Limit value → Min/Max	min	
	Limit value → Trip point	80.00	
	Limit value → Hysteresis	10.00	
	Limit value → Operating mode	passive	
	Limit value → Restart inhibit	OFF	
	Limit value → Response delay	0 s	
	Fault message	not selected	
Output → Rel4 ¹	Limit value (Trip)	On (selected)	
	Limit value → Assignment	disabled	
	Limit value → Min/Max	min	
	Limit value → Trip point	80.00	
	Limit value → Hysteresis	10.00	
	Limit value → Restart inhibit	OFF	
	Limit value → Response delay	0 s	
		Fault message	not selected
Service	Language	ENG	
	Password	OFF	

Table 7.1

- ¹ Relay contact outputs for KFD2-HLC-Ex1.D.4S
² Relay contact outputs for KFD2-HLC-Ex1.D.2W

PROCESS AUTOMATION – PROTECTING YOUR PROCESS



Worldwide Headquarters

Pepperl+Fuchs GmbH
68307 Mannheim · Germany
Tel. +49 621 776-0
E-Mail: info@de.pepperl-fuchs.com

For the Pepperl+Fuchs representative
closest to you check www.pepperl-fuchs.com/contact

www.pepperl-fuchs.com

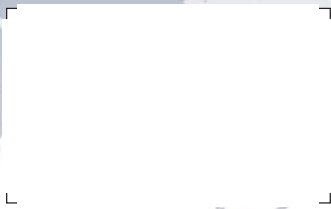

 **PEPPERL+FUCHS**
PROTECTING YOUR PROCESS



SCATTERGOOD & JOHNSON LTD

ELECTRICAL ENGINEERING & FLUID CONTROL DISTRIBUTORS

Est.1899

At Scattergood & Johnson Ltd, we pride ourselves on being a technical distributor to specialist industries.

Working with a range of quality product suppliers across a number of specialist markets, we are not your average 'box shifter' - we are your technical and supply chain partner.

We fully support every product we sell - for free! Our internal team and external sales engineers can answer any product or application question, no matter the complexity.

Backing up this technical ability is a range of 50,000+ products available from stock for nationwide next day delivery (same day if required!), or you can collect what you need from any of our trade counters around the UK.

Select your specialist interest below to learn more about how we can help.



Online, In Branch and On the Road - Scattergood & Johnson Ltd, there when you need us.

www.scatts.co.uk