

**Features**

- 2-channel isolated barrier
- 24 V DC supply (Power Rail)
- Current output up to 700 Ω load
- HART I/P and valve positioner
- Lead breakage monitoring
- Accuracy 0.05 %
- Terminal blocks with test sockets
- Up to SIL 2 acc. to IEC 61508

**Function**

This isolated barrier is used for intrinsic safety applications. It drives SMART I/P converters, electrical valves, and positioners in hazardous areas.

Digital signals are superimposed on the analog values at the field or control side and are transferred bi-directionally.

Current transferred across the DC/DC converter is repeated at terminals 1, 2 and 4, 5.

An open field circuit presents a high input impedance to the control side to allow lead breakage monitoring by control system.

If the loop resistance for the digital communication is too low, an internal resistor of 250 Ω between terminals 8, 9 and 11, 12 is available, which may be used as the HART communication resistor.

Sockets for the connection of a HART communicator are integrated into the terminals of the device.

A unique collective error messaging feature is available when used with the Power Rail system.

**Assembly**

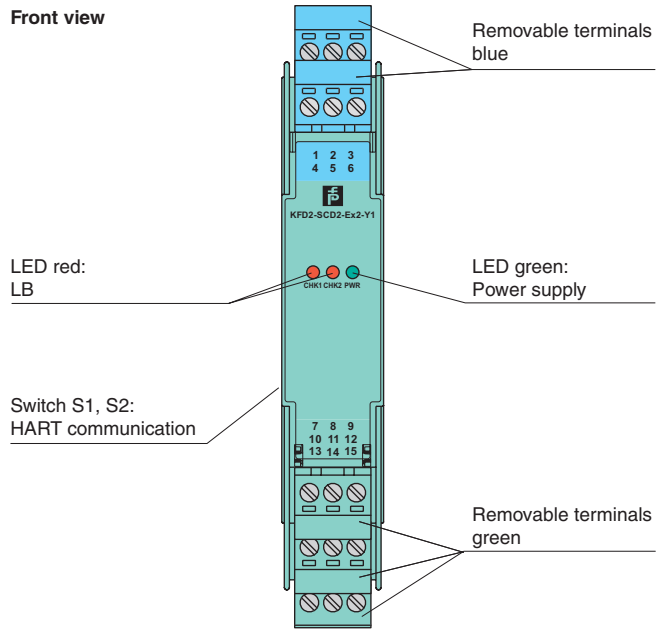

**SIL 2**



**Connection**

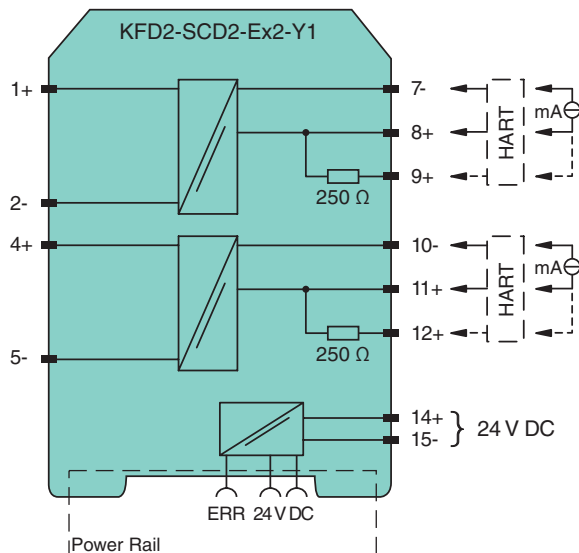
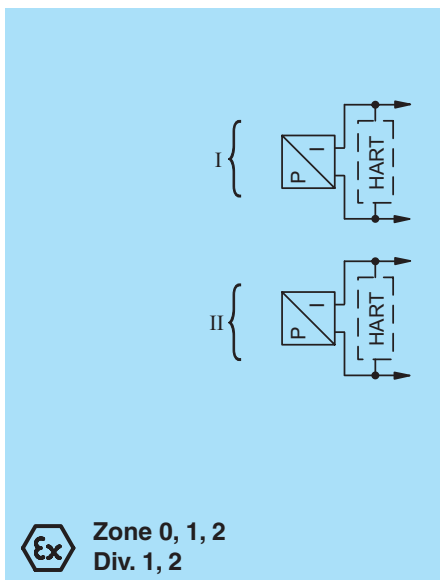

Release date 2019-06-27 14:25 Date of issue 2019-06-27 219996\_eng.xml

Refer to "General Notes Relating to Pepperl+Fuchs Product Information".

Pepperl+Fuchs Group  
www.pepperl-fuchs.com

USA: +1 330 486 0002  
pa-info@us.pepperl-fuchs.com

Germany: +49 621 776 2222  
pa-info@de.pepperl-fuchs.com

Singapore: +65 6779 9091  
pa-info@sg.pepperl-fuchs.com

<b>General specifications</b>		
Signal type		Analog output
<b>Functional safety related parameters</b>		
Safety Integrity Level (SIL)		SIL 2
<b>Supply</b>		
Connection		Power Rail or terminals 14+, 15-
Rated voltage	$U_r$	20 ... 35 V DC
Ripple		within the supply tolerance
Power dissipation		1.4 W at 20 mA into 10 V (equivalent to 500 $\Omega$ ) load
Power consumption		1.8 W at 20 mA
<b>Input</b>		
Connection side		control side
Connection		terminals 7-, 8+, (9+); 10-, 11+, (12+)
Voltage drop		approx. 4 V (equivalent to 200 $\Omega$ at 20 mA)
Input resistance		> 100 k $\Omega$ , when wiring resistance in the field > 16 V (equivalent to 800 $\Omega$ at 20 mA)
Current		4 ... 20 mA limited to approx. 25 mA
<b>Output</b>		
Connection side		field side
Connection		terminals 1+, 2-; 4+, 5-
Current		4 ... 20 mA
Load		0 ... 700 $\Omega$
Voltage		$\geq$ 14 V at 20 mA
<b>Transfer characteristics</b>		
Accuracy		0.05 %
<b>Deviation</b>		
After calibration		at 20 °C (68 °F): 10 $\mu$ A incl. non-linearity, calibration, hysteresis, supply and load changes
Influence of ambient temperature		1 $\mu$ A/K
Rise time		< 100 $\mu$ s at bounce from 10 ... 90 %
<b>Galvanic isolation</b>		
Input/power supply		functional insulation, rated insulation voltage 50 V AC
Input/input		functional insulation, rated insulation voltage 50 V AC
<b>Indicators/settings</b>		
Display elements		LEDs
Control elements		DIP-switch
Configuration		via DIP switches
Labeling		space for labeling at the front
<b>Directive conformity</b>		
<b>Electromagnetic compatibility</b>		
Directive 2014/30/EU		EN 61326-1:2013 (industrial locations)
<b>Conformity</b>		
Electromagnetic compatibility		NE 21:2011
Degree of protection		IEC 60529:2001
Protection against electrical shock		UL 61010-1:2004
<b>Ambient conditions</b>		
Ambient temperature		-20 ... 60 °C (-4 ... 140 °F)
<b>Mechanical specifications</b>		
Degree of protection		IP20
Connection		screw terminals
Mass		approx. 150 g
Dimensions		20 x 124 x 115 mm (0.8 x 4.9 x 4.5 inch) , housing type B2
Mounting		on 35 mm DIN mounting rail acc. to EN 60715:2001
<b>Data for application in connection with hazardous areas</b>		
<b>EU-type examination certificate</b>		
Marking		II (1)G [Ex ia Ga] IIC ,  II (1)D [Ex ia Da] IIIC ,  I (M1) [Ex ia Ma] I
Output		[Ex ia Ga] IIC, [Ex ia Da] IIIC, [Ex ia Ma] I
Voltage	$U_o$	25.2 V
Current	$I_o$	93 mA
Power	$P_o$	585 mW
<b>Supply</b>		
Maximum safe voltage	$U_m$	250 V $r_{ms}$ (Attention! The rated voltage can be lower.)
<b>Input</b>		
Maximum safe voltage	$U_m$	250 V $r_{ms}$ (Attention! The rated voltage can be lower.)
<b>Certificate</b>		
Marking		II 3G Ex nA II T4 [device in zone 2]

Release date 2019-06-27 14:25 Date of issue 2019-06-27 219996\_eng.xml

Refer to "General Notes Relating to Pepperl+Fuchs Product Information".

Pepperl+Fuchs Group  
www.pepperl-fuchs.com

USA: +1 330 486 0002  
pa-info@us.pepperl-fuchs.com

Germany: +49 621 776 2222  
pa-info@de.pepperl-fuchs.com

Singapore: +65 6779 9091  
pa-info@sg.pepperl-fuchs.com

<b>Galvanic isolation</b>	
Input/Output	safe electrical isolation acc. to IEC/EN 60079-11, voltage peak value 375 V
Output/power supply	safe electrical isolation acc. to IEC/EN 60079-11, voltage peak value 375 V
<b>Directive conformity</b>	
Directive 2014/34/EU	EN 60079-0:2012+A11:2013 , EN 60079-11:2012 , EN 60079-15:2010
<b>International approvals</b>	
UL approval	
Control drawing	116-0173 (cULus)
<b>IECEx approval</b>	
Approved for	[Zone 0] [Ex ia] IIC, [Ex iaD], [Ex ia] I
<b>General information</b>	
Supplementary information	Observe the certificates, declarations of conformity, instruction manuals, and manuals where applicable. For information see <a href="http://www.pepperl-fuchs.com">www.pepperl-fuchs.com</a> .
<b>Accessories</b>	
Optional accessories	- power feed module KFD2-EB2(.R4A.B)(.SP) - universal power rail UPR-03(-M)(-S) - profile rail K-DUCT-BU(-UPR-03)

**Additional information**

**Lead monitoring, input characteristics**

During lead breakage (> 16 V) in the field the input resistance is > 100 kΩ, the field current is < 1 mA and the red LED is flashing. The voltage drop at the current input (terminals 7-, 8+ and 10-, 11+) is lower than 4 V. Thus, it corresponds to an input resistance of 200 Ω at 20 mA. The AC input impedance corresponds to the load impedance of the unit.

**Adjustment SMART function**

When using positioners, which do not meet the HART standard, set the switches to the 1 position (non SMART function) (see adjustment table).

Switch		Position	Function
Channel 1	Channel 2		
S1.1	S2.1	0	SMART
S1.2	S2.2	0	SMART
All other switch settings			non SMART

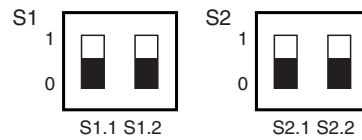

*If you are using field devices with high input impedance and a control system with low output impedance, check whether HART transparency is working correctly.*

*If necessary, deactivate HART transparency via the DIP switches. If the impedances are combined as described above, you can for example use the device KCD2-SCD-Ex1 alternatively.*



# SCATTERGOOD & JOHNSON LTD

ELECTRICAL ENGINEERING & FLUID CONTROL DISTRIBUTORS

Est.1899

At Scattergood & Johnson Ltd, we pride ourselves on being a technical distributor to specialist industries.

Working with a range of quality product suppliers across a number of specialist markets, we are not your average 'box shifter' - we are your technical and supply chain partner.

We fully support every product we sell - for free! Our internal team and external sales engineers can answer any product or application question, no matter the complexity.

Backing up this technical ability is a range of 50,000+ products available from stock for nationwide next day delivery (same day if required!), or you can collect what you need from any of our trade counters around the UK.

Select your specialist interest below to learn more about how we can help.



Online, In Branch and On the Road - Scattergood & Johnson Ltd, there when you need us.

# [www.scatts.co.uk](http://www.scatts.co.uk)