

APPLICATION GUIDELINE

VALVES – ISOLATED BARRIERS

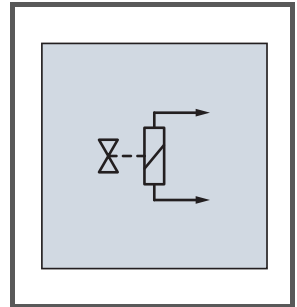

With regard to the supply of products, the current issue of the following document is applicable: The General Terms of Delivery for Products and Services of the Electrical Industry, published by the Central Association of the Electrical Industry (Zentralverband Elektrotechnik und Elektroindustrie (ZVEI) e.V.) in its most recent version as well as the supplementary clause: "Expanded reservation of proprietorship"

1	Intrinsically Safe Valve Control	4
2	The Solenoid Driver.....	5
3	The Valve	6
4	Connection of Valve with Solenoid Driver	8
5	The Booster Valve.....	10
6	Connection of Booster Valve with Solenoid Driver	12
7	Valve Data and Valve List	16

1

Intrinsically Safe Valve Control

Many factors determine whether the connection between a valve and a solenoid driver is suitable. A number of factors must be taken into account to ensure that intrinsically safe valves will work perfectly and will also satisfy all criteria for intrinsic safety. The technical data should be used in a worst-case calculation to ensure that the valve will work even when the valve and solenoid driver tolerances are unhelpful or the ambient temperature is raised.

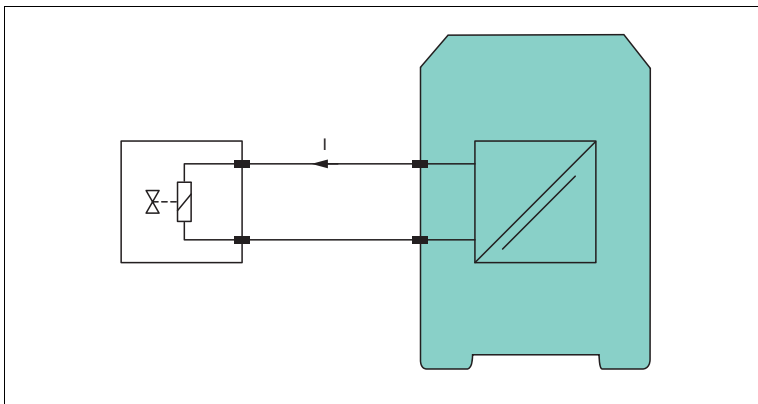

Figure 1.1 Connection of valve with solenoid driver

The individual components and their functional connection are described below.

2 The Solenoid Driver

In principle, the solenoid driver consists of a voltage source with internal resistance (→ see Figure 3.1 on page 6).

Open circuit voltage U_s

The open-circuit voltage is the output terminal voltage with no field current ($I = 0$).

Internal resistance R_i

The internal resistance reduces the available voltage depending on the output current. This resistance R_i is made up of Ex protection and other internal components.

Line fault detection current I_{LFD}

Some devices inject a low test current into the field circuit for line fault detection purposes. This current is selected so that it does not actuate the valve. The only time this I_{LFD} can cause problems is with low-power valves.

3

The Valve

Looking at it from the simplest level, a valve can be seen as an electromechanical relay consisting of a coil with connected mechanism (→ see Figure 3.1 on page 6).

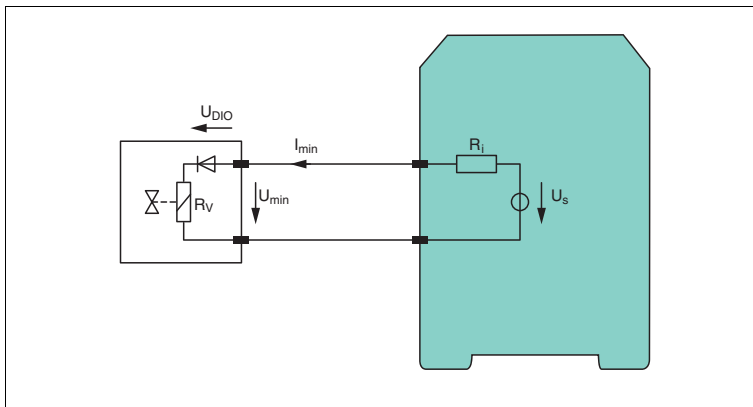

Figure 3.1 Electric signals in the valve and solenoid driver

The following parameters must be set in order to control a valve reliably.

Minimum switching voltage U_{\min}

The valve actuates above the minimum switching voltage. This value takes account of all internal voltage drops. If U_{\min} is not specified, it can be calculated from I_{\min} , R_v and U_{DIO} .

Minimum switching current I_{\min}

If the minimum switching current is exceeded, the valve is reliably actuated.

Holding current I_{hold}

The holding current I_{hold} is a less relevant parameter in terms of its practical application in the case of classical valves; if the current falls below this value, the actuated valve is released again. This parameter is significant in the case of booster valves (see chapter 5).

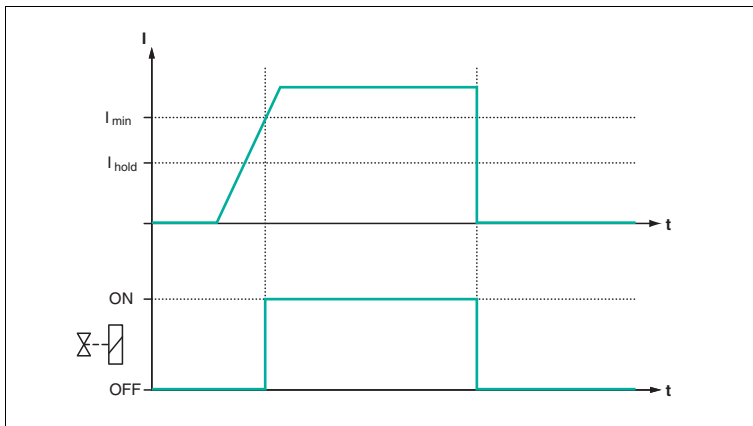

Figure 3.2 Valve current characteristic

Coil resistance R_v

In calculations, the maximum coil resistance (at maximum operating temperature) should be used. The specific resistance of metals is temperature-dependent and increases with temperature. If the data sheet specifies only the resistance at the nominal temperature, then the factor 1.004/K (copper) can be used to calculate the value at maximum operating temperature.

Voltage U_{DIO} of internal diodes

The voltage drop U_{DIO} of any polarity protection diodes that may be installed in the valve must be taken into account. These values are rarely specified in the data sheets and are only of significance if U_{min} is not specified.

Summary

When calculating which valve to use, either U_{min} and I_{min} or the parameters I_{min} , R_v and U_{DIO} are of any significance. If U_{min} is not specified, it can be calculated using equation 1.

Equation 1

$$U_{min} = U_{DIO} + R_v \times I_{min}$$

4

Connection of Valve with Solenoid Driver

Taking into account the maximum line resistance R_{Lmax} of the field wiring and using the technical data, a suitable solenoid driver for an existing valve can be determined. The aim is to find a line resistance that enables the field circuit to be operated.

In the following figure, the line resistance is shown in the field circuit.

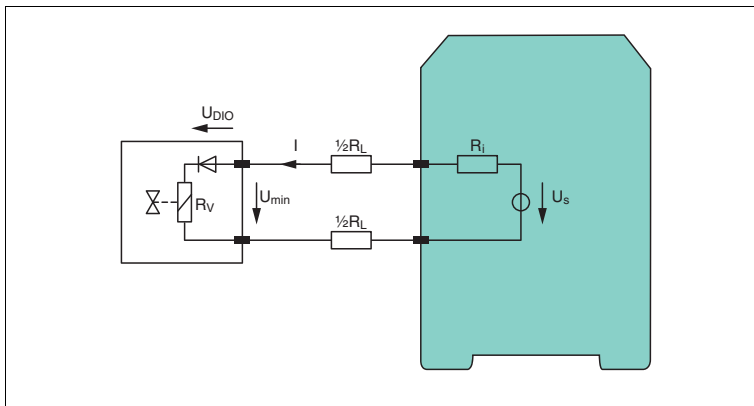

Figure 4.1 Field circuit with line resistance

This enables us to deduce the following equations and reformulate them in terms of R_L .

Equation 2
$U_s - U_{min} = (R_L + R_i) \times I_{min}$
$R_{Lmax} < (U_s - U_{min}) / I_{min} - R_i$

This line resistance R_L must not be exceeded.

If the minimum voltage U_{min} of the valve is not specified, the line resistance R_L can be determined from the internal diode voltage U_{DIO} and the coil resistance R_V .

Equation 3
$U_s - U_{DIO} = (R_L + R_i + R_V) \times I_{min}$
$R_{Lmax} < (U_s - U_{DIO}) / I_{min} - (R_i + R_V)$

In both cases, negative values of R_L mean that the selected solenoid driver cannot be used with this valve.

The functional connection of the valve and solenoid driver is exemplified using the following examples and the values specified on the data sheet.

Example 1

- **Valve Herion 2053**

$$U_{\min} = 19 \text{ V}$$

$$I_{\min} = 13 \text{ mA}$$

- **Solenoid driver KFD2-SL2-Ex***

$$R_i = 272 \Omega$$

$$U_s = 24 \text{ V}$$

The following maximum line resistance is derived from equation 2:

$$R_{L\max} = (24 \text{ V} - 19 \text{ V}) / 0.013 \text{ A} - 272 \Omega = 113 \Omega$$

For a specific cable resistance of 59 Ω/km (at 0.6 mm^2) the maximum cable length is calculated to be approx. 2 km. This ensures that the field circuit operates correctly.

Example 2

- **Valve Samson 3775-13**

$$R_v (60 \text{ }^\circ\text{C}) = 4640 \Omega$$

$$U_{\min} = 18.6 \text{ V}$$

$$I_{\min} = 3.75 \text{ mA}$$

- **Solenoid driver KFD2-SL2-Ex***

$$R_i = 272 \Omega$$

$$U_s = 24 \text{ V}$$

The following maximum line resistance is derived from equation 2:

$$R_{L\max} = (24 \text{ V} - 18.6 \text{ V}) / 0.00375 \text{ A} - 272 \Omega = 1168 \Omega$$

Here, too, correct operation is ensured.

5 The Booster Valve

With some valves that are directly actuated, the simplification described above needs to be stated more precisely. As the actuating current of the solenoid driver will be too low to actuate the valve in intrinsically safe circuits, the valve contains a capacitor circuit (→ see Figure 5.1 on page 10). After switching on, this capacitor circuit charges until the actuating energy or minimum switching voltage U_{\min} of the valve is reached.

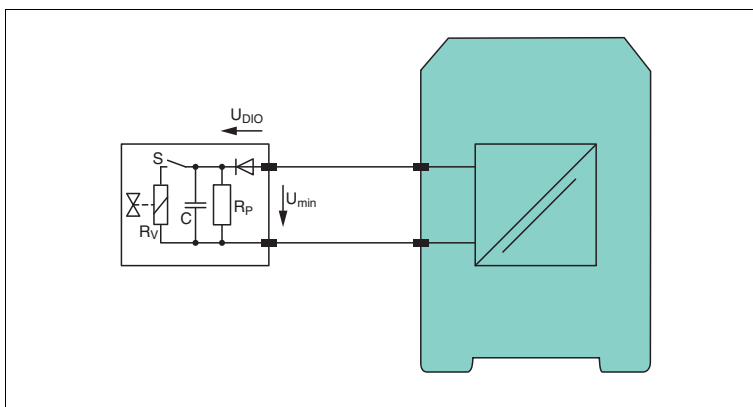

Figure 5.1 Booster valve

Important parameters of booster valves are:

Quiescent current I_{quiet}

Regardless of the switching state, the internal electronics of directly-switched valves requires a quiescent current that is shown by the parallel resistor R_p (→ see Figure 5.1 on page 10).

Minimum switching voltage U_{\min}

As with the standard valves, the minimum switching voltage U_{\min} is significant in this instance as well. After switching on the valve, the internal boost capacitor is charged until the energy required to actuate the valve is reached. This, together with the diode voltage, gives the minimum switching voltage that has to be applied to the valve terminals.

Holding current I_{hold}

Once the valve has been actuated, it requires a minimum current I_{hold} to prevent it dropping off again.

Line fault detection current I_{LFD}

Some devices inject a low test current into the field circuit for line fault detection purposes. This current is selected so that it does not actuate the valve. The only time this current I_{LFD} can cause problems with low-power valves, when the boost capacitor is charged above the minimum switching voltage U_{min} .

Voltage U_{DIO} of internal diodes

The voltage drop U_{DIO} of any polarity protection diodes that may be installed in the valve must be taken into account. These values are rarely specified in the data sheets and are only of significance if U_{min} is not specified.

6

Connection of Booster Valve with Solenoid Driver

Taking into account the maximum line resistance R_{Lmax} and using the technical data, a suitable solenoid driver for a valve can also be determined. The aim is to find a line resistance that enables the field circuit to be operated.

The following figure shows the block diagram of a booster valve and solenoid driver with line resistance.

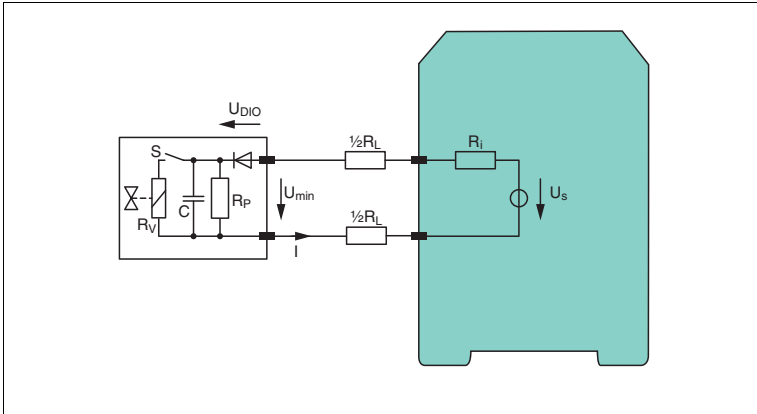

Figure 6.1 Electrical circuit with booster valve

To make the behavior of booster valves easier to understand, the following figure shows the time response of the valve as it is switched on and off.

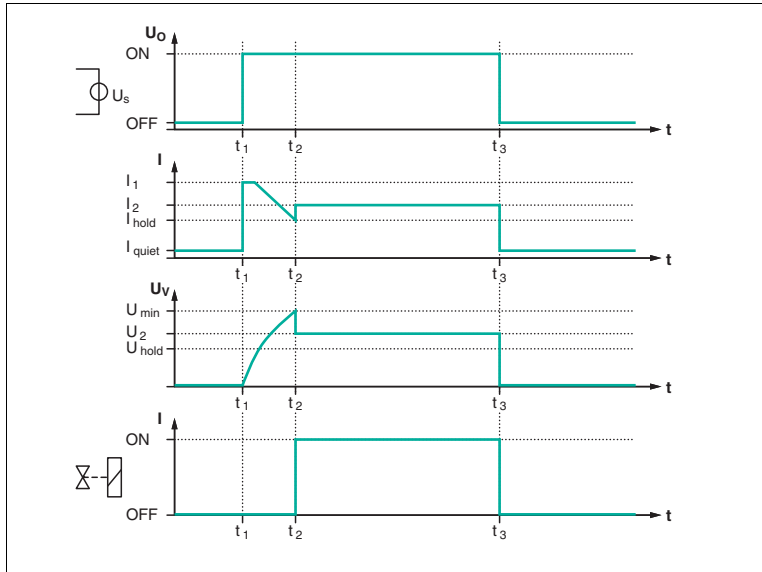

Figure 6.2 Time sequence when actuating the booster valve

Switching on at time t_1

The solenoid driver switches U_s on the valve. The current I rises through the initially uncharged capacitor and the resistances increase rapidly to the value I_1 . The current I_1 is limited by the internal resistance R_i and the line resistance R_L .

Equation 4

$$I_1 = (U_s - U_{DIO}) / (R_L + R_i)$$

The capacitor voltage in the valve increases exponentially up to the minimum switching voltage U_{min} . The open circuit voltage U_s must be greater than U_{min} in order for the valve to switch at all. To be precise, the value U_s must conform to the requirement of equation 5, as R_p has to take account of the closed circuit current I_{quiet} . This equation is reformulated in terms of R_L .

Equation 5

$$U_s > U_{min} + I_{quiet} \times (R_L + R_i)$$

$$R_{Lmax} < (U_s - U_{min}) / I_{quiet} - R_i$$

This line resistance R_L must not be exceeded.

Status after switching on at time t_2

The minimum switching voltage U_{\min} of the valve is reached. The energy stored in the capacitor is used to actuate the valve, which causes the voltage to drop to U_2 . The field current I adapts itself to the value I_2 .

Equation 6

$$I_2 = (U_s - U_{DIO}) / (R_L + R_i + R_v)$$

$$R_{L\max} < (U_s - U_{DIO}) / I_2 - (R_i + R_v)$$

The current I_2 must be greater than the holding current I_{hold} described above. The parallel resistance R_p can be ignored in this case. If the holding voltage U_{hold} as well as the holding current I_{hold} is known, this parameter can also be used. This gives us the same situation as before using a classical valve.

Equation 7

$$U_2 > U_{\text{hold}} = U_s - I_{\text{hold}} \times (R_L + R_i)$$

$$R_{L\max} < (U_s - U_{\text{hold}}) / I_{\text{hold}} - R_i$$

When choosing the solenoid driver, the conditions from equation 5, 6 or 7 must be met.

Switching off at time t_3

Two special points need to be looked at after the valve has been switched off. A low-level line fault detection current I_{LFD} is injected into the circuit for line fault detection purposes.

1. If the parallel resistance R_p is large, or putting it another way, the closed circuit current I_{quiet} of the valve is low, the capacitor C may under certain circumstances be charged, causing the valve to actuate unexpectedly. The remedy in this case is to connect a $R_p = 4,7\text{ k}\Omega$ to $10\text{ k}\Omega$ parallel resistor to the valve terminals (→ see Figure 6.3 on page 15).
2. The line fault detection current I_{LFD} may not be sufficient to start up the electronics with the charging mimic of the capacitor. In this case the valve remains highly resistive for the line fault detection current. The solenoid driver signals a lead breakage. Connecting the parallel resistor to the valve terminals described in 1. will again rectify the situation.

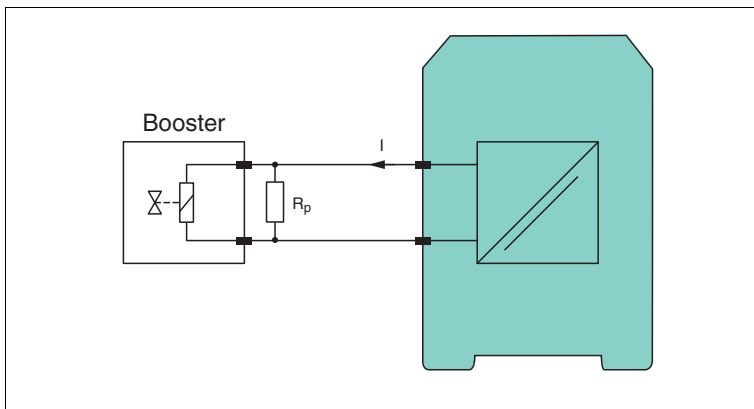

Figure 6.3 Parallel connected resistor near booster valve

7 Valve Data and Valve List

Pepperl+Fuchs has drawn up a compatibility list to help users choose the most suitable solenoid driver for their valves. This compatibility list has been created using the above equations and data collected from the valve manufacturers, and is available on the internet (www.pepperl-fuchs.com) and in the Engineer's Guide of interface technology.







PROCESS AUTOMATION – PROTECTING YOUR PROCESS



Worldwide Headquarters

Pepperl+Fuchs GmbH
68307 Mannheim · Germany
Tel. +49 621 776-0
E-mail: info@de.pepperl-fuchs.com

For the Pepperl+Fuchs representative
closest to you check www.pepperl-fuchs.com/pfcontact

www.pepperl-fuchs.com

 **PEPPERL+FUCHS**
PROTECTING YOUR PROCESS



SCATTERGOOD & JOHNSON LTD

ELECTRICAL ENGINEERING & FLUID CONTROL DISTRIBUTORS

Est.1899

At Scattergood & Johnson Ltd, we pride ourselves on being a technical distributor to specialist industries.

Working with a range of quality product suppliers across a number of specialist markets, we are not your average 'box shifter' - we are your technical and supply chain partner.

We fully support every product we sell - for free! Our internal team and external sales engineers can answer any product or application question, no matter the complexity.

Backing up this technical ability is a range of 50,000+ products available from stock for nationwide next day delivery (same day if required!), or you can collect what you need from any of our trade counters around the UK.

Select your specialist interest below to learn more about how we can help.



Online, In Branch and On the Road - Scattergood & Johnson Ltd, there when you need us.

www.scatts.co.uk