



- 1-channel
- Output EEx ia IIC
- 24 V DC supply voltage
- Logic input for connection and disconnection
- Up to SIL3 acc. to IEC 61508

Current limit 35 mA
KFD2-SL-Ex1.48

Function

The KFD2-SL-Ex1.48 and KFD2-SL-Ex1.48.90A each have a logic input which is isolated from the power supply. The field device is controlled across the logic input.

Voltage signals in a range of 5 V DC ... 35 V DC are accepted as Logic-1. Logic-0 must lie in the range of 0 V DC ... 2.2 V DC.

The open circuit voltage at the output is dependent on the supply voltage. The relationship is as follows:
(supply voltage - 1 V) x 1.3.

The voltage limit at the output is set by a supply voltage of 20 V DC. Therefore, the maximum open circuit voltage at the output is 26 V DC.

The output current is limited to 35.3 mA (KFD2-SL-Ex1.48) or 45.3 mA (KFD2-SL-Ex1.48.90A) depending on the model.

The output, logic input and power supply are galvanically isolated from each other.

Application

- Control/supply of intrinsically safe valves, audible alarms, indicators etc.
- Control/supply of semiconductors (e. g. LED or LCD units)

Connection

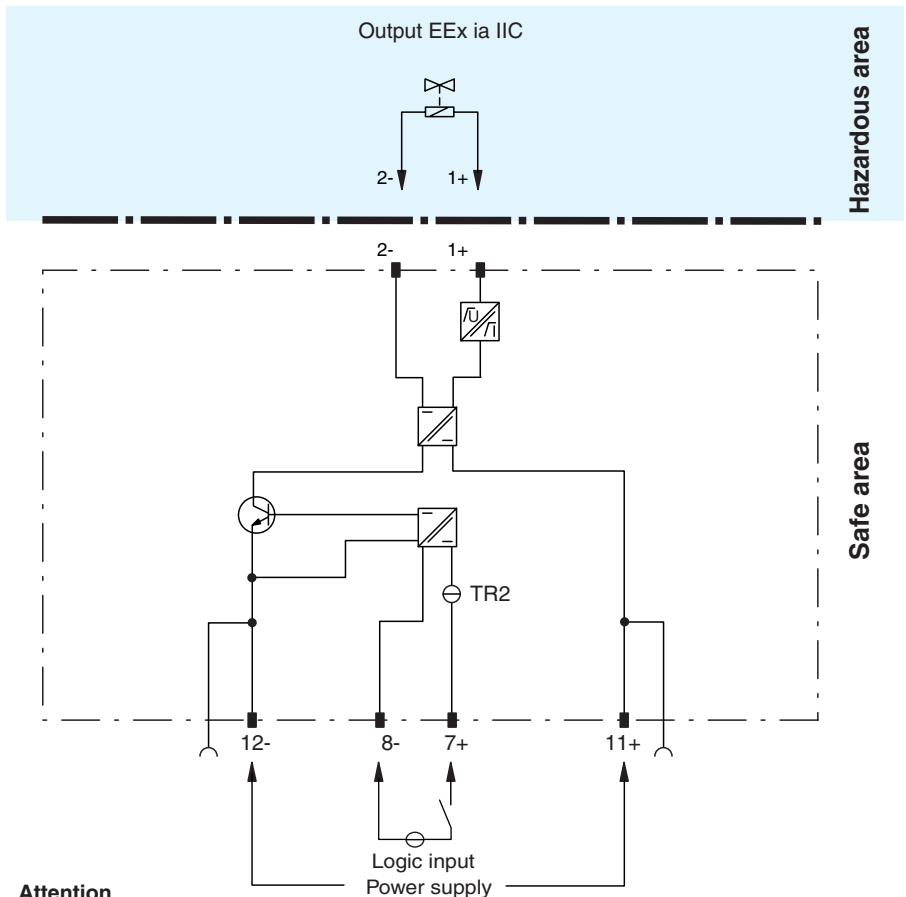

Attention
changed terminal numbers

new	12-	8-	7+	11+
old	8-	10-	9+/11+	7+

Composition

Front view

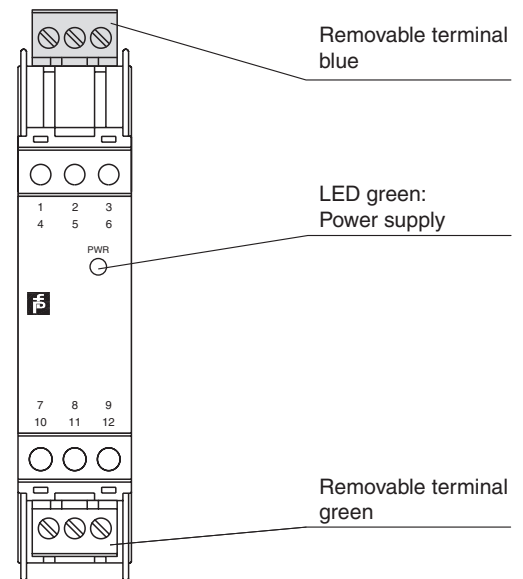

Release date 2007-10-05 13:52 Date of issue 2007-10-05 072045_ENG.xml

Supply	
Connection	Power Rail or terminals 11+, 12-
Rated voltage	5 ... 35 V DC
No-load supply current	7 mA at 19 V nominal supply voltage 70 mA at 35 V nominal supply voltage
Power loss	1.3 W
Input	
Connection	terminals 7+, 8-
Signal level	1-signal: 3 ... 35 V DC 0-signal: 0 ... 2 V DC input current: approx. 5 mA at 24 V DC
Output	
Internal resistor	≤ 303 Ω
Limit	current I_o : ≥ 35.3 mA voltage U_o : 12.1 V
Open loop voltage	≥ 22.8 V
Connection	terminals 1+, 2-
Output rated operating current	35 mA
Output signal	these values are valid for the rated operational voltage 20 ... 35 V DC
Directive conformity	
Electromagnetic compatibility	
Directive 89/336/EC	EN 61326, EN 50081-2
Conformity	
Electromagnetic compatibility	NE 21
Protection degree	IEC 60529
Ambient conditions	
Ambient temperature	-20 ... 60 °C (253 ... 333 K)
Mechanical specifications	
Protection degree	IP20
Mass	approx. 100 g
Dimensions	20 x 107 x 115 mm (0.8 x 4.2 x 4.5 in) , housing type B1
Data for application in conjunction with hazardous areas	
EC-Type Examination Certificate	BAS 00 ATEX 7216 , for additional certificates see www.pepperl-fuchs.com
Group, category, type of protection	⊕ II (1)GD [EEx ia] IIC (-20 °C ≤ T _a ≤ 60 °C) [circuit(s) in zone 0/1/2]
Output	EEx ia IIC
Voltage U_o	25.2 V
Current I_o	93 mA
Power P_o	590 mW
Type of protection [EEx ia]	
Explosion group	IIA IIB IIC
External capacitance	2.9 μF 0.82 μF 0.107 μF
External inductance	36.02 mH 17.72 mH 4.3 mH
Input	
Safety maximum voltage U_m	250 V (Attention! The rated voltage can be lower.)
Statement of conformity	
Group, category, type of protection, temperature classification	⊕ II 3G EEx nA II T4 bzw. EEx nAC IIC T4 [device in zone 2]
Electrical isolation	
Input/output	safe electrical isolation acc. to EN 50020, voltage peak value 375 V
Input/power supply	safe electrical isolation acc. to EN 50020, voltage peak value 375 V
Output/power supply	safe electrical isolation acc. to EN 50020, voltage peak value 375 V
Directive conformity	
Directive 94/9 EC	EN 50014, EN 50020, EN 50021
Entity parameter	
Certification number	4Z6A5.AX
FM control drawing	No. 116-0129
Suitable for installation in division 2	yes
Connection	terminals 1, 2
Input I	
Voltage V_{OC}	28 V
Current I_t	93 mA
Explosion group	A&B C&E D, F&G
Max. external capacitance C_a	0.14 μF 0.43 μF 1.14 μF
Max. external inductance L_a	4.18 mH 5.83 mH 34.21 mH

Release date 2007-10-05 13:52 Date of issue 2007-10-05 072045_ENG.xml

General information

Supplementary information

EC-Type Examination Certificate, Statement of Conformity, Declaration of Conformity and instructions have to be observed. For information see www.pepperl-fuchs.com.

Notes

Output circuit diagram

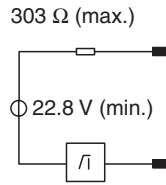

Output characteristic for input voltage

20 V ... 35 V

E: Curve angle point (U_E, I_E)

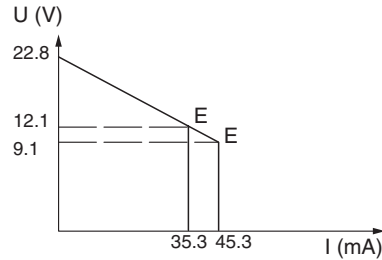

Accessories

Power feed modules KFD2-EB2...

The power feed module is used to supply the devices with 24 V DC via the Power Rail. The fuse-protected power feed module can supply up to 100 individual devices depending on the power consumption of the devices. A galvanically isolated mechanical contact uses the Power Rail to transmit collective error messages.

Power Rail UPR-03

The Power Rail UPR-03 is a complete unit consisting of the electrical inset and an aluminium profile rail 35 mm x 15 mm. To make electrical contact, the devices are simply engaged.

The Power Rail must not be fed via the device terminals of the individual devices!