

Features

- 1-channel isolated barrier
- 24 V DC supply (Power Rail)
- Dry contact or NAMUR inputs
- Relay contact output
- Line fault detection (LFD)
- Reversible mode of operation
- Up to SIL 2 acc. to IEC 61508/IEC 61511

Function

This isolated barrier is used for intrinsic safety applications. It transfers digital signals (NAMUR sensors/mechanical contacts) from a hazardous area to a safe area.

The proximity sensor or switch controls a form C changeover relay contact for the safe area load. The barrier output changes state when the input signal changes state. The normal output state can be reversed using switch S1. Switch S3 is used to enable or disable line fault detection of the field circuit.

During an error condition, the relay reverts to its de-energized state and the LEDs indicate the fault according to NAMUR NE44.

A unique collective error messaging feature is available when used with the Power Rail system.

Assembly

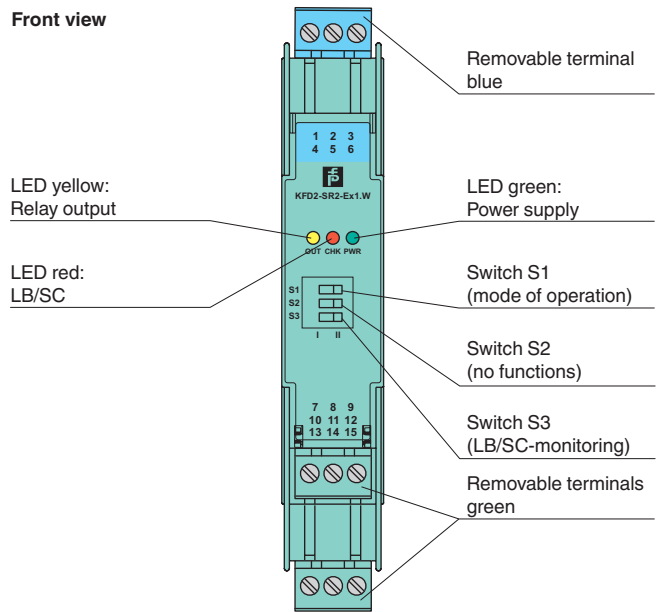

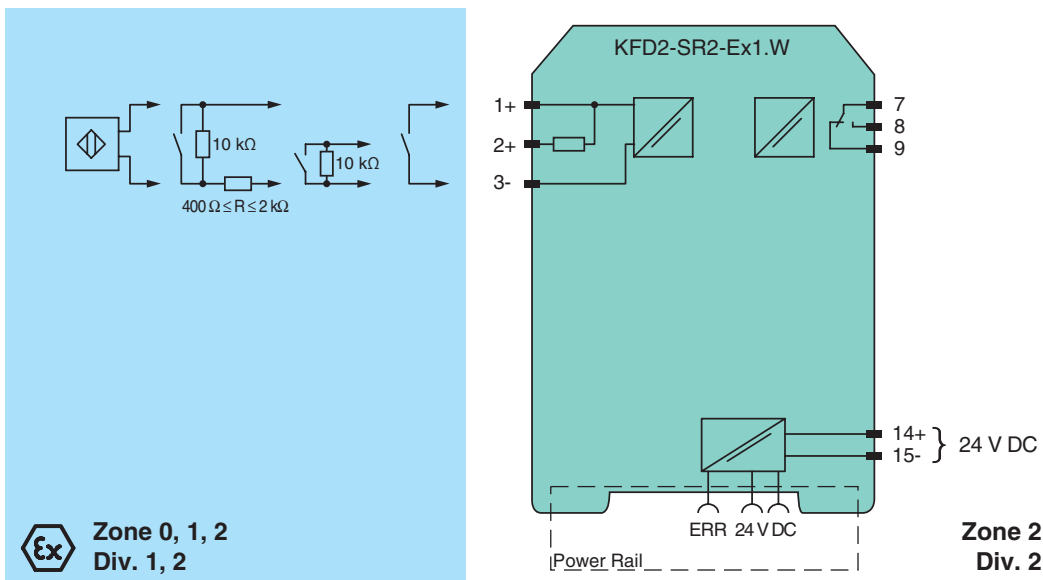

Connection



Release date 2018-06-19 07:42 Date of issue 2018-06-19 132958_eng.xml

Refer to "General Notes Relating to Pepperl+Fuchs Product Information".

| | | |
|--|-------|--|
| General specifications | | |
| Signal type | | Digital Input |
| Functional safety related parameters | | |
| Safety Integrity Level (SIL) | | SIL 2 |
| Supply | | |
| Connection | | Power Rail or terminals 14+, 15- |
| Rated voltage | U_r | 20 ... 30 V DC |
| Ripple | | $\leq 10 \%$ |
| Rated current | I_r | $\leq 30 \text{ mA}$ |
| Power dissipation | | 0.7 W |
| Power consumption | | $< 0.9 \text{ W}$ |
| Input | | |
| Connection side | | field side |
| Connection | | terminals 1+, 2+, 3- |
| Rated values | | acc. to EN 60947-5-6 (NAMUR) |
| Open circuit voltage/short-circuit current | | approx. 8 V DC / approx. 8 mA |
| Switching point/switching hysteresis | | 1.2 ... 2.1 mA / approx. 0.2 mA |
| Line fault detection | | breakage $I \leq 0.1 \text{ mA}$, short-circuit $I > 6 \text{ mA}$ |
| Pulse/Pause ratio | | $\geq 20 \text{ ms} / \geq 20 \text{ ms}$ |
| Output | | |
| Connection side | | control side |
| Connection | | terminals 7, 8, 9 |
| Output | | signal ; relay |
| Contact loading | | 253 V AC/2 A/cos $\phi > 0.7$; 126.5 V AC/4 A/cos $\phi > 0.7$; 40 V DC/2 A resistive load |
| Minimum switch current | | 2 mA / 24 V DC |
| Energized/De-energized delay | | approx. 20 ms / approx. 20 ms |
| Mechanical life | | 10^7 switching cycles |
| Transfer characteristics | | |
| Switching frequency | | $< 10 \text{ Hz}$ |
| Galvanic isolation | | |
| Input/Output | | reinforced insulation according to IEC/EN 61010-1, rated insulation voltage 300 V _{eff} |
| Input/power supply | | reinforced insulation according to IEC/EN 61010-1, rated insulation voltage 300 V _{eff} |
| Output/power supply | | reinforced insulation according to IEC/EN 61010-1, rated insulation voltage 300 V _{eff} |
| Indicators/settings | | |
| Display elements | | LEDs |
| Control elements | | DIP-switch |
| Configuration | | via DIP switches |
| Labeling | | space for labeling at the front |
| Directive conformity | | |
| Electromagnetic compatibility | | |
| Directive 2014/30/EU | | EN 61326-1:2013 (industrial locations) |
| Low voltage | | |
| Directive 2014/35/EU | | EN 61010-1:2010 |
| Conformity | | |
| Electromagnetic compatibility | | NE 21:2006 |
| Degree of protection | | IEC 60529:2001 |
| Input | | EN 60947-5-6:2000 |
| Ambient conditions | | |
| Ambient temperature | | -20 ... 60 °C (-4 ... 140 °F) |
| Mechanical specifications | | |
| Degree of protection | | IP20 |
| Connection | | screw terminals |
| Mass | | approx. 150 g |
| Dimensions | | 20 x 119 x 115 mm (0.8 x 4.7 x 4.5 inch) , housing type B2 |
| Mounting | | on 35 mm DIN mounting rail acc. to EN 60715:2001 |
| Data for application in connection with hazardous areas | | |
| EU-Type Examination Certificate | | PTB 00 ATEX 2080 |
| Marking | |  II (1)G [Ex ia Ga] IIC  II (1)D [Ex ia Da] IIIC  I (M1) [Ex ia Ma] I |
| Input | | Ex ia |
| Voltage | U_o | 10.5 V |
| Current | I_o | 13 mA |
| Power | P_o | 34 mW (linear characteristic) |

Release date 2018-06-19 07:42 Date of issue 2018-06-19 132958_eng.xml

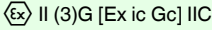
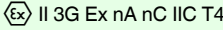
| | | |
|--------------------------------|-------|---|
| Supply | | |
| Maximum safe voltage | U_m | 253 V AC / 125 V DC (Attention! U_m is no rated voltage.) |
| Output | | |
| Contact loading | | 253 V AC/2 A/cos $\phi > 0.7$; 126.5 V AC/4 A/cos $\phi > 0.7$; 40 V DC/2 A resistive load |
| Maximum safe voltage | U_m | 253 V AC (Attention! The rated voltage can be lower.) |
| Fault indication output | | |
| Maximum safe voltage | U_m | 40 V DC (Attention! U_m is no rated voltage.) |
| Certificate | | PF 08 CERT 0803 |
| Marking | |  |
| Input | | |
| Voltage | U_o | 10.5 V |
| Current | I_o | 13 mA |
| Power | P_o | 34 mW (linear characteristic) |
| Output | | |
| Contact loading | | 253 V AC/2 A/cos $\phi > 0.7$; 126.5 V AC/4 A/cos $\phi > 0.7$; 40 V DC/2 A resistive load |
| Certificate | | TÜV 99 ATEX 1493 X |
| Marking | |  |
| Output | | |
| Contact loading | | 50 V AC/4 A/cos $\phi > 0.7$; 40 V DC/2 A resistive load |
| Galvanic isolation | | |
| Input/Output | | safe electrical isolation acc. to IEC/EN 60079-11, voltage peak value 375 V |
| Input/power supply | | safe electrical isolation acc. to IEC/EN 60079-11, voltage peak value 375 V |
| Directive conformity | | |
| Directive 2014/34/EU | | EN 60079-0:2012+A11:2013 , EN 60079-11:2012 , EN 60079-15:2010 |
| International approvals | | |
| FM approval | | |
| Control drawing | | 116-0035 |
| UL approval | | |
| Control drawing | | 116-0145 |
| CSA approval | | |
| Control drawing | | 116-0047 |
| IECEX approval | | |
| Approved for | | [Ex ia Ga] IIC, [Ex ia Da] IIIC, [Ex ia Ma] I |
| General information | | |
| Supplementary information | | Observe the certificates, declarations of conformity, instruction manuals, and manuals where applicable. For information see www.pepperl-fuchs.com . |

Configuration

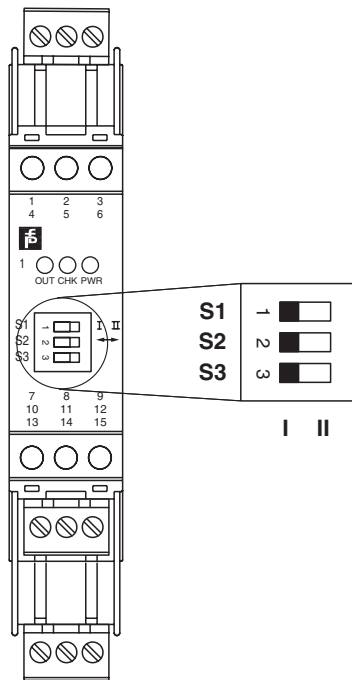

Switch position

| S | Function | | Position |
|---|--|-------------------------|----------|
| 1 | Mode of operation Output I (relay) energized | with high input current | I |
| | | with low input current | II |
| 2 | no function | | |
| 3 | Line fault detection | ON | I |
| | | OFF | II |

Operating status

| Control circuit | Input signal |
|---|--------------------|
| Initiator high impedance/ contact opened | low input current |
| Initiator low impedance/ contact closed | high input current |
| Lead breakage, lead short-circuit | Line fault |

Factory settings: switch 1, 2 and 3 in position I

Maximum switching power of output contacts

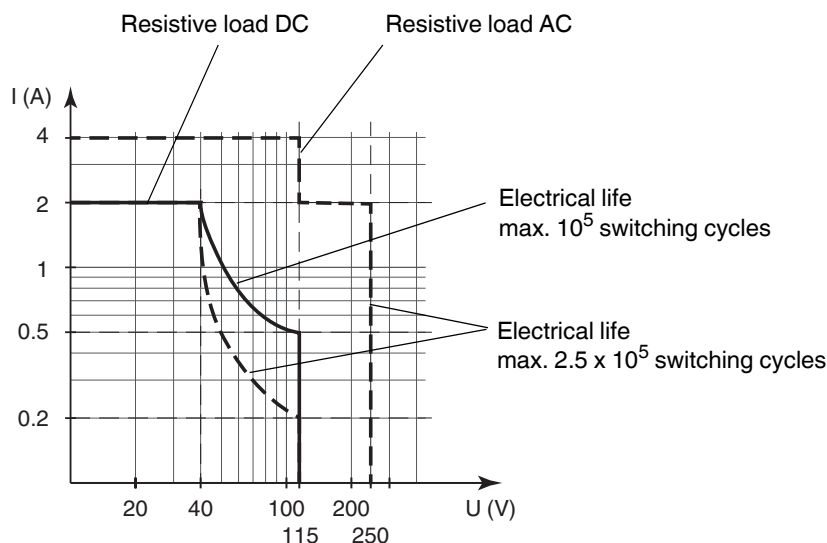

The maximum number of switching cycles is depending on the electrical load and may be higher when reduced currents and voltages are applied.

Accessories

Power feed module KFD2-EB2

The power feed module is used to supply the devices with 24 V DC via the Power Rail. The fuse-protected power feed module can supply up to 150 individual devices depending on the power consumption of the devices. Collective error messages received from the Power Rail activate a galvanically-isolated mechanical contact.

Power Rail UPR-03

The Power Rail UPR-03 is a complete unit consisting of the electrical insert and an aluminium profile rail 35 mm x 15 mm. To make electrical contact, the devices are simply engaged.

Profile Rail K-DUCT with Power Rail

The profile rail K-DUCT is an aluminum profile rail with Power Rail insert and two integral cable ducts for system and field cables. Due to this assembly no additional cable guides are necessary.



Power Rail and Profile Rail must not be fed via the device terminals of the individual devices!

Release date 2018-06-19 07:42 Date of issue 2018-06-19 132958_eng.xml



SCATTERGOOD & JOHNSON LTD

ELECTRICAL ENGINEERING & FLUID CONTROL DISTRIBUTORS

Est.1899

At Scattergood & Johnson Ltd, we pride ourselves on being a technical distributor to specialist industries.

Working with a range of quality product suppliers across a number of specialist markets, we are not your average 'box shifter' - we are your technical and supply chain partner.

We fully support every product we sell - for free! Our internal team and external sales engineers can answer any product or application question, no matter the complexity.

Backing up this technical ability is a range of 50,000+ products available from stock for nationwide next day delivery (same day if required!), or you can collect what you need from any of our trade counters around the UK.

Select your specialist interest below to learn more about how we can help.



Online, In Branch and On the Road - Scattergood & Johnson Ltd, there when you need us.

www.scatts.co.uk