

Features

- 2-channel isolated barrier
- 24 V DC supply (Power Rail)
- Dry contact or NAMUR inputs
- Usable as signal splitter (1 input and 2 outputs)
- 2 x 2 relay contact outputs with AND logic
- Line fault detection (LFD)
- Reversible mode of operation
- Up to SIL 2 acc. to IEC 61508

Function

This isolated barrier is used for intrinsic safety applications. It transfers digital signals (NAMUR sensors/mechanical contacts) from a hazardous area to a safe area.

Each sensor or switch controls two form A normally open relay contacts for the safe area load. The normal output state can be reversed using switches S1 and S2. Switch S3 is used to enable or disable line fault detection of the field circuit.

During an error condition, the relays revert to their de-energized state and the LEDs indicate the fault according to NAMUR NE44.

A unique collective error messaging feature is available when used with the Power Rail system.

Assembly

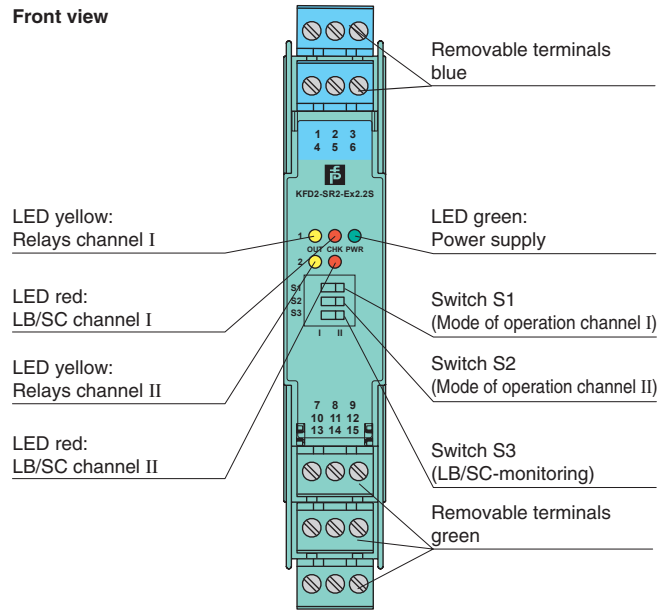

SIL 2

Connection

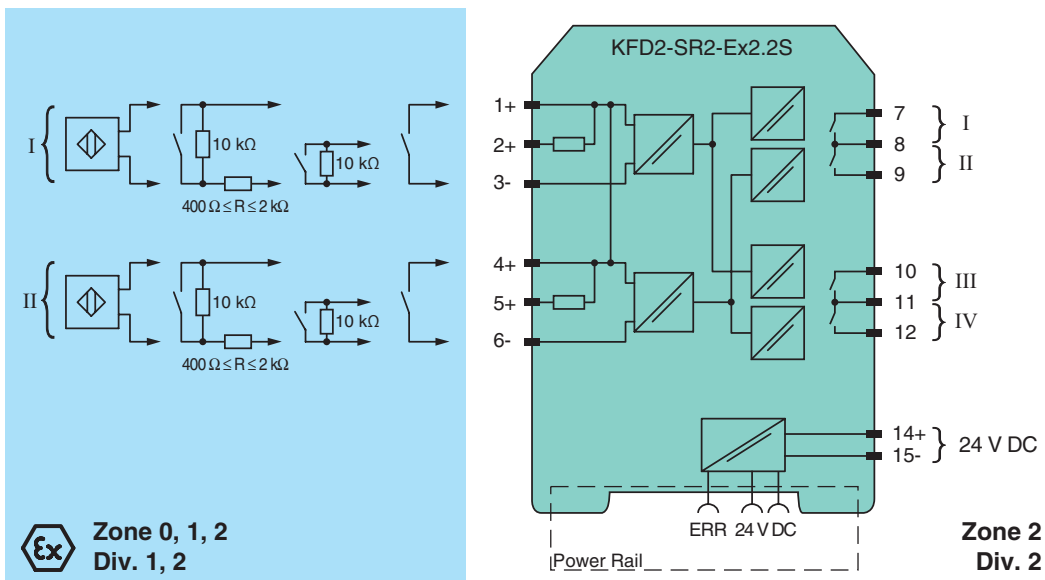

Release date 2018-05-08 08:09 Date of issue 2018-05-08 18:284_eng.xml

Refer to "General Notes Relating to Pepperl+Fuchs Product Information".

Pepperl+Fuchs Group
www.pepperl-fuchs.com

USA: +1 330 486 0002
pa-info@us.pepperl-fuchs.com

Germany: +49 621 776 2222
pa-info@de.pepperl-fuchs.com

Singapore: +65 6779 9091
pa-info@sg.pepperl-fuchs.com

General specifications		
Signal type		Digital Input
Functional safety related parameters		
Safety Integrity Level (SIL)		SIL 2
Supply		
Connection		Power Rail or terminals 14+, 15-
Rated voltage	U_r	20 ... 30 V DC
Ripple		$\leq 10 \%$
Rated current	I_r	$\leq 50 \text{ mA}$
Power dissipation		1 W
Power consumption		$< 1.3 \text{ W}$
Input		
Connection side		field side
Connection		terminals 1+, 2+, 3-; 4+, 5+, 6-
Rated values		acc. to EN 60947-5-6 (NAMUR)
Open circuit voltage/short-circuit current		approx. 8 V DC / approx. 8 mA
Switching point/switching hysteresis		1.2 ... 2.1 mA / approx. 0.2 mA
Line fault detection		breakage $I \leq 0.1 \text{ mA}$, short-circuit $I > 6 \text{ mA}$
Pulse/Pause ratio		$\geq 20 \text{ ms} / \geq 20 \text{ ms}$
Output		
Connection side		control side
Connection		output I: terminals 7, 8 ; output II: terminals 8, 9 ; output III: terminals 10, 11 ; output IV: terminals 11, 12
Output I, II, III, IV		channel 1, 2; relay
Contact loading		50 V AC/1 A/cos $\phi > 0.7$; 40 V DC/1 A resistive load
Minimum switch current		1 mA / 24 V DC
Energized/De-energized delay		approx. 20 ms / approx. 20 ms
Mechanical life		10^8 switching cycles
Collective error message		Power Rail
Transfer characteristics		
Switching frequency		$\leq 10 \text{ Hz}$
Galvanic isolation		
Input/Output		reinforced insulation according to IEC/EN 61010-1, rated insulation voltage 300 V _{eff}
Input/power supply		reinforced insulation according to IEC/EN 61010-1, rated insulation voltage 300 V _{eff}
Output/power supply		basic insulation according to IEC/EN 61010-1, rated insulation voltage 32 V _{eff} , functional insulation, rated insulation voltage 50 V _{eff}
Output/Output		basic insulation according to IEC/EN 61010-1, rated insulation voltage 32 V _{eff} , functional insulation, rated insulation voltage 50 V _{eff}
Indicators/settings		
Display elements		LEDs
Control elements		DIP-switch
Configuration		via DIP switches
Labeling		space for labeling at the front
Directive conformity		
Electromagnetic compatibility		
Directive 2014/30/EU		EN 61326-1:2013 (industrial locations)
Low voltage		
Directive 2014/35/EU		EN 61010-1:2010
Conformity		
Electromagnetic compatibility		NE 21:2004
Degree of protection		IEC 60529:2001
Input		EN 60947-5-6:2000
Ambient conditions		
Ambient temperature		-20 ... 60 °C (-4 ... 140 °F)
Mechanical specifications		
Degree of protection		IP20
Connection		screw terminals
Mass		approx. 150 g
Dimensions		20 x 119 x 115 mm (0.8 x 4.7 x 4.5 inch) , housing type B2
Mounting		on 35 mm DIN mounting rail acc. to EN 60715:2001
Data for application in connection with hazardous areas		
EU-Type Examination Certificate		PTB 00 ATEX 2083
Marking		 II (1)GD [EEx ia] IIC [circuit(s) in zone 0/1/2]
Input		EEx ia IIC
Voltage	U_o	10.5 V

Release date 2018-05-08 08:09 Date of issue 2018-05-08 181284_eng.xml

Current	I_o	13 mA
Power	P_o	34 mW (linear characteristic)
Supply		
Maximum safe voltage	U_m	253 V AC / 125 V DC (Attention! U_m is no rated voltage.)
Output		
Contact loading		50 V AC/1 A/cos $\phi > 0.7$; 40 V DC/1 A resistive load
Maximum safe voltage	U_m	253 V AC (Attention! The rated voltage can be lower.)
Certificate		TÜV 99 ATEX 1493 X
Marking		⊕ II 3G Ex nA nC IIC T4
Galvanic isolation		
Input/input		not available
Input/Output		safe electrical isolation acc. to IEC/EN 60079-11, voltage peak value 375 V
Input/power supply		safe electrical isolation acc. to IEC/EN 60079-11, voltage peak value 375 V
Directive conformity		
Directive 2014/34/EU		EN 60079-0:2012+A11:2013 , EN 60079-11:2012 , EN 60079-15:2010
International approvals		
FM approval		
Control drawing		116-0035
CSA approval		
Control drawing		116-0047
General information		
Supplementary information		Observe the certificates, declarations of conformity, instruction manuals, and manuals where applicable. For information see www.pepperl-fuchs.com .

Configuration

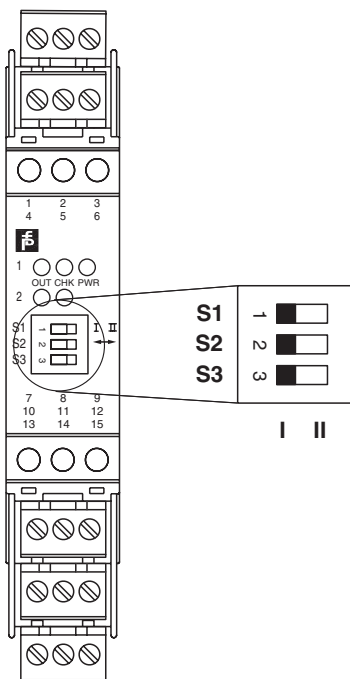

Switch position

S	Function		Position
1	Mode of operation Channel I (relay) energized	with high input current	I
		with low input current	II
2	Mode of operation Channel II (relay) energized	with high input current	I
		with low input current	II
3	Line fault detection	ON	I
		OFF	II

Operating status

Control circuit	Input signal
Initiator high impedance/ contact opened	low input current
Initiator low impedance/ contact closed	high input current
Lead breakage, lead short-circuit	Line fault

Factory settings: switch 1, 2 and 3 in position I

Accessories

Power feed module KFD2-EB2

The power feed module is used to supply the devices with 24 V DC via the Power Rail. The fuse-protected power feed module can supply up to 150 individual devices depending on the power consumption of the devices. Collective error messages received from the Power Rail activate a galvanically-isolated mechanical contact.

Power Rail UPR-03

The Power Rail UPR-03 is a complete unit consisting of the electrical insert and an aluminium profile rail 35 mm x 15 mm. To make electrical contact, the devices are simply engaged.

Profile Rail K-DUCT with Power Rail

The profile rail K-DUCT is an aluminum profile rail with Power Rail insert and two integral cable ducts for system and field cables. Due to this assembly no additional cable guides are necessary.



Power Rail and Profile Rail must not be fed via the device terminals of the individual devices!



SCATTERGOOD & JOHNSON LTD

ELECTRICAL ENGINEERING & FLUID CONTROL DISTRIBUTORS

Est.1899

At Scattergood & Johnson Ltd, we pride ourselves on being a technical distributor to specialist industries.

Working with a range of quality product suppliers across a number of specialist markets, we are not your average 'box shifter' - we are your technical and supply chain partner.

We fully support every product we sell - for free! Our internal team and external sales engineers can answer any product or application question, no matter the complexity.

Backing up this technical ability is a range of 50,000+ products available from stock for nationwide next day delivery (same day if required!), or you can collect what you need from any of our trade counters around the UK.

Select your specialist interest below to learn more about how we can help.



Online, In Branch and On the Road - Scattergood & Johnson Ltd, there when you need us.

www.scatts.co.uk