

Features

- 2-channel isolated barrier
- 24 V DC supply (Power Rail)
- Input 2-wire SMART transmitters
- Output 0/4 mA ... 20 mA
- Terminals with test points
- Up to SIL 2 acc. to IEC 61508

Function

This isolated barrier is used for intrinsic safety applications. The device supplies 2-wire SMART transmitters in a hazardous area.

It transfers the analog input signal to the safe area as an isolated current value.

Digital signals may be superimposed on the input signal in the hazardous or safe area and are transferred bi-directionally.

If the HART communication resistance in the loop is too low, the internal resistance of 250 Ω between terminals 8, 9 and 11, 12 can be used.

Test sockets for the connection of HART communicators are integrated into the terminals of the device.

Application

The device supports the following SMART protocols:

- HART
- BRAIN
- Foxboro

Assembly

Front view

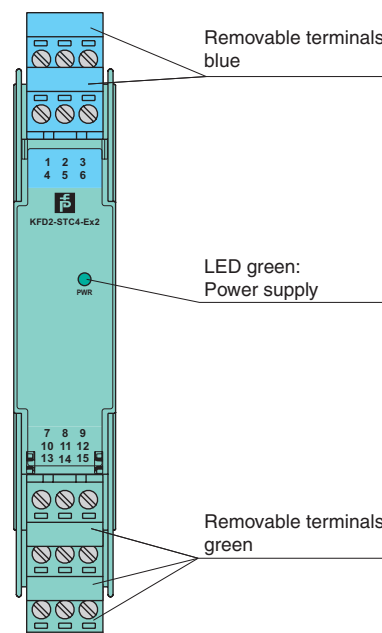

Connection

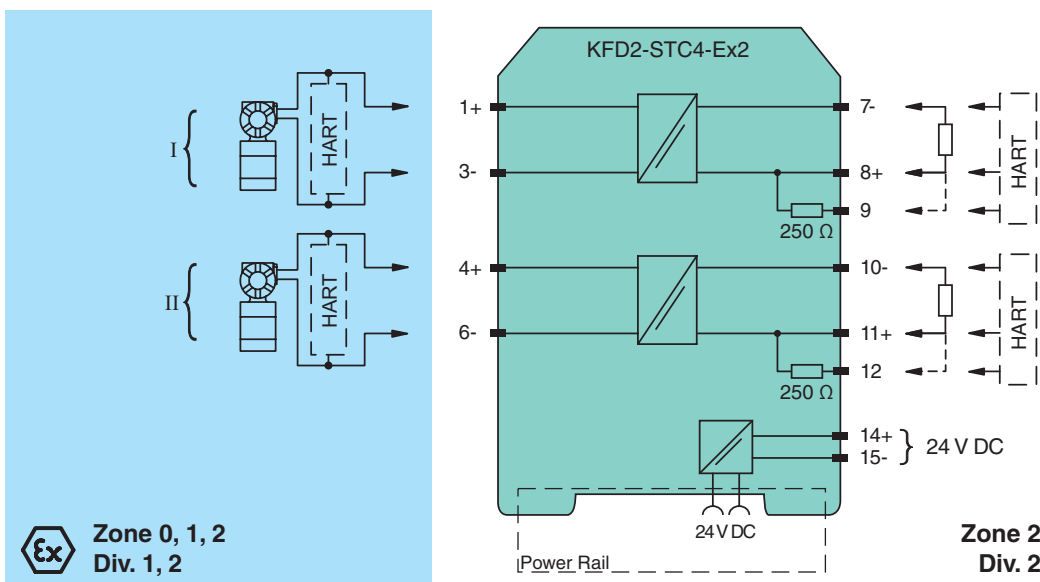

Release date 2017-08-09 14:38 Date of issue 2017-08-10 283699_eng.xml

Refer to "General Notes Relating to Pepperl+Fuchs Product Information".

General specifications		
Signal type		Analog input
Functional safety related parameters		
Safety Integrity Level (SIL)		SIL 2
Supply		
Connection		Power Rail or terminals 14+, 15-
Rated voltage	U_r	20 ... 35 V DC
Ripple		within the supply tolerance
Power dissipation		1.8 W
Power consumption		≤ 2.7 W
Input		
Connection side		field side
Connection		terminals 1+, 3-, 4+, 6-
Input signal		0/4 ... 20 mA
Available voltage		≥ 16 V at 20 mA, terminals 1+, 3
Output		
Connection side		control side
Connection		terminals 7-, 8+; 10-, 11+
Load		0 ... 550 Ω at 20 mA
Output signal		0/4 ... 20 mA (overload > 25 mA)
Ripple		≤ 50 μA _{rms}
Transfer characteristics		
Deviation		at 20 °C (68 °F), 0/4 ... 20 mA ≤ 10 μA incl. calibration, linearity, hysteresis, loads and fluctuations of supply voltage
Influence of ambient temperature		0.25 μA/K
Frequency range		field side into the control side: band width with 1 V _{pp} signal 0 ... 7.5 kHz (-3 dB) safe area to hazardous area: band width with 1 V _{SS} signal 0.3 ... 7.5 kHz (-3 dB)
Settling time		200 μs
Rise time/fall time		20 μs
Galvanic isolation		
Output/power supply		functional insulation, rated insulation voltage 50 V AC
Output/Output		functional insulation, rated insulation voltage 50 V AC
Indicators/settings		
Display elements		LED
Labeling		space for labeling at the front
Directive conformity		
Electromagnetic compatibility		
Directive 2014/30/EU		EN 61326-1:2013 (industrial locations)
Conformity		
Electromagnetic compatibility		NE 21:2011
Degree of protection		IEC 60529:2001
Protection against electrical shock		UL 61010-1:2012
Ambient conditions		
Ambient temperature		-20 ... 60 °C (-4 ... 140 °F)
Mechanical specifications		
Degree of protection		IP20
Connection		screw terminals
Mass		approx. 150 g
Dimensions		20 x 124 x 115 mm (0.8 x 4.9 x 4.5 inch) , housing type B2
Mounting		on 35 mm DIN mounting rail acc. to EN 60715:2001
Data for application in connection with hazardous areas		
EU-Type Examination Certificate		BAS 99 ATEX 7025 X
Marking		⊕ II (1)G [Ex ia Ga] IIC , ⊕ II (1)D [Ex ia Da] IIIC , ⊕ I (M1) [Ex ia Ma] I
Input		[Ex ia Ga] IIC, [Ex ia Da] IIIC, [Ex ia Ma] I
Voltage	U_o	25.2 V
Current	I_o	93 mA
Power	P_o	0.586 W
Supply		
Maximum safe voltage	U_m	250 V (Attention! The rated voltage can be lower.)
Certificate		
Marking		⊕ II 3G Ex nA II T4 [device in zone 2]
Galvanic isolation		
Input/Output		safe electrical isolation acc. to IEC/EN 60079-11, voltage peak value 375 V
Input/power supply		safe electrical isolation acc. to IEC/EN 60079-11, voltage peak value 375 V

Release date 2017-08-09 14:38 Date of issue 2017-08-10 283699_eng.xml

Directive conformity	
Directive 2014/34/EU	EN 60079-0:2012+A11:2013 , EN 60079-11:2012 , EN 60079-15:2010
International approvals	
UL approval	
Control drawing	116-0428 (cULus)
IECEX approval	IECEX BAS 04.0015X IECEX CML 15.0055X
Approved for	[Ex ia Ga] IIC, [Ex ia Da] IIIC, [Ex ia Ma] I Ex nA IIC T4 Gc
General information	
Supplementary information	Observe the certificates, declarations of conformity, instruction manuals, and manuals where applicable. For information see www.pepperl-fuchs.com .

Accessories

Power feed module KFD2-EB2

The power feed module is used to supply the devices with 24 V DC via the Power Rail. The fuse-protected power feed module can supply up to 150 individual devices depending on the power consumption of the devices. Collective error messages received from the Power Rail activate a galvanically-isolated mechanical contact.

Power Rail UPR-03

The Power Rail UPR-03 is a complete unit consisting of the electrical insert and an aluminium profile rail 35 mm x 15 mm. To make electrical contact, the devices are simply engaged.

Profile Rail K-DUCT with Power Rail

The profile rail K-DUCT is an aluminum profile rail with Power Rail insert and two integral cable ducts for system and field cables. Due to this assembly no additional cable guides are necessary.



Power Rail and Profile Rail must not be fed via the device terminals of the individual devices!

Release date 2017-08-09 14:38 Date of issue 2017-08-10 283699_eng.xml



SCATTERGOOD & JOHNSON LTD

ELECTRICAL ENGINEERING & FLUID CONTROL DISTRIBUTORS

Est.1899

At Scattergood & Johnson Ltd, we pride ourselves on being a technical distributor to specialist industries.

Working with a range of quality product suppliers across a number of specialist markets, we are not your average 'box shifter' - we are your technical and supply chain partner.

We fully support every product we sell - for free! Our internal team and external sales engineers can answer any product or application question, no matter the complexity.

Backing up this technical ability is a range of 50,000+ products available from stock for nationwide next day delivery (same day if required!), or you can collect what you need from any of our trade counters around the UK.

Select your specialist interest below to learn more about how we can help.



Online, In Branch and On the Road - Scattergood & Johnson Ltd, there when you need us.

www.scatts.co.uk