

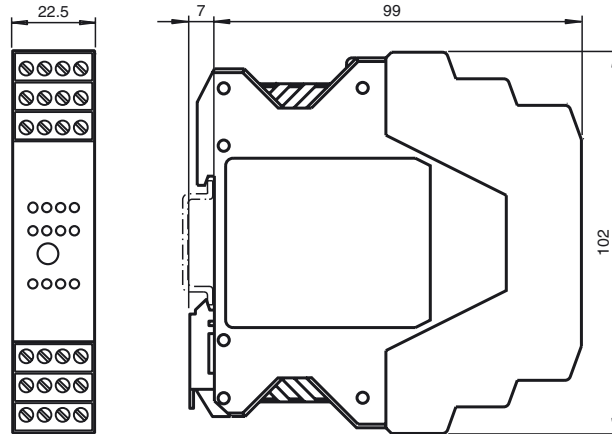

62
Spec 2.1

Dimensions



Electrical connection

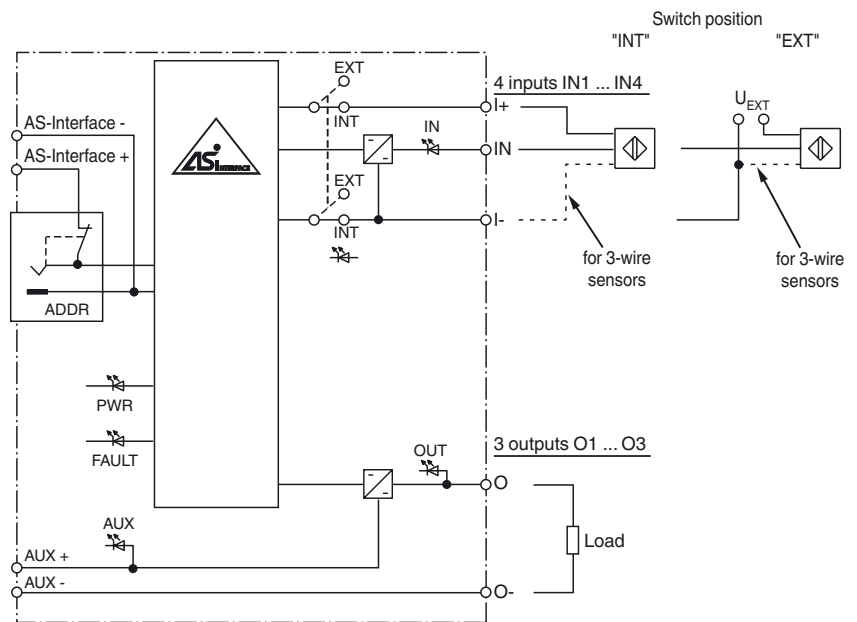

Model number

VBA-4E3A-KE-ZEJQ/E2L

KE switch cabinet module
4 inputs and 3 outputs

Features

- Housing with removable and color coded terminals
- Communication monitoring
- Inputs for 2- and 3-wire sensors
- Addressing jack
- Power supply of outputs from the external auxiliary voltage
- Selectable supply to the sensors: External or from the module
- Function display for bus, external auxiliary voltage, internal sensor supply, inputs, and outputs
- Red LED per channel, lights up in the event of output overload
- Switchable lead breakage detection (outputs)
- A/B slave with extended addressing possibility for up to 62 slaves

Indicating / Operating means

ATTENTION

Do not connect the terminals I+, IN and I- with any external potential when switch set to "INT"

Sensor supply:
INT = internal sensor supply (from AS-i)
EXT = external sensor supply

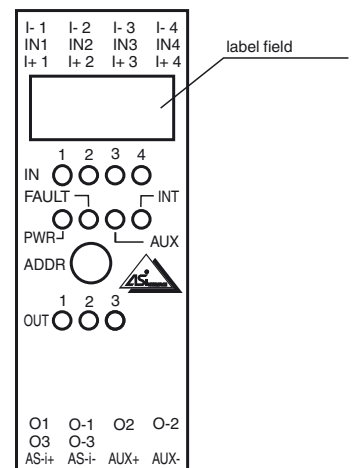
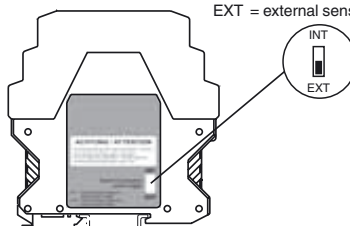

Release date: 2019-01-09 10:02 Date of issue: 2019-01-09 228630_eng.xml

Technical data

General specifications

Slave type	A/B slave
AS-Interface specification	V3.0
Required master specification	≥ V2.1
UL File Number	E223772

Indicators/operating means

LED FAULT	Error display; red LED red: communication error, i.e. address is 0 red flashing: overload internal input supply, i.e. overload or lead interruption outputs
LED INT	Internal input supply active; LED green
LED PWR	AS-Interface voltage; green LED green: voltage OK flashing green: address 0
LED AUX	ext. auxiliary voltage U_{AUX} ; dual LED green/red green: voltage OK red: reverse voltage
LED IN	switching state (input); 4 LED yellow
LED OUT	Switching state (output); 3 LED yellow/red yellow: Output active red: Output overload or lead breakage

Electrical specifications

Auxiliary voltage (input)	U_{EXT}	12 ... 30 V DC PELV
Auxiliary voltage (output)	U_{AUX}	20 ... 30 V DC PELV
Rated operating voltage	U_e	26.5 ... 31.6 V from AS-Interface
Rated operating current	I_e	≤ 35 mA (without sensors) / max. 190 mA
Protection class		III
Surge protection		U_{EXT} , U_{AUX} , U_e : Over voltage category III, safe isolated power supplies (PELV)

Input

Number/Type	4 inputs for 2- or 3-wire sensors (PNP), DC
Supply	from AS-Interface (switch position INT, default settings) or external U_{EXT} (switch position EXT)
Voltage	21 ... 31 V DC (INT)
Current loading capacity	≤ 150 mA, overload- and short-circuit protected (INT)
Input current	≤ 9 mA (limited internally)
Switching point	according to DIN EN 61131-2 (Type 2)
0 (unattenuated)	≤ 3 mA
1 (attenuated)	≥ 5 mA
Signal delay	< 1 ms (input/AS-Interface)

Output

Number/Type	3 electronic outputs, PNP, overload and short-circuit proof
Supply	from external auxiliary voltage U_{AUX}
Current	O1 max. 3 A, O2/O3 max. 1.5 A, total 6 A ($T_B \leq 40^\circ\text{C}$) O1 max. 2 A, O2/O3 max. 1 A, total 4 A ($T_B \leq 60^\circ\text{C}$)
Voltage	≥ ($U_{AUX} - 0.5\text{ V}$)
Usage category	DC-13

Directive conformity

Electromagnetic compatibility	
Directive 2014/30/EU	EN 62026-2:2013 EN 61000-6-2:2005, EN 61000-6-4:2007

Standard conformity

Degree of protection	EN 60529:2000
Fieldbus standard	EN 62026-2:2013
Input	EN 61131-2:2004
Emitted interference	EN 61000-6-4:2007
AS-Interface	EN 62026-2:2013
Noise immunity	EN 61000-6-2:2005, EN 61326-1:2006, EN 62026-2:2013

Programming instructions

Profile	S-7.A.0
IO code	7
ID code	A
ID1 code	7
ID2 code	0

Data bits (function via AS-Interface)	input	output
D0	IN1	O1
D1	IN2	O2
D2	IN3	O3
D3	IN4	-

Parameter bits (programmable via AS-i) function

P0	Communication monitoring P0 = 0 monitoring = off, the outputs maintain the status if communication fails P0 = 1 monitoring = on, i.e. if communication fails, the outputs are deenergised (default settings)
P1	Input filter P1 = 0 input filter on, pulse suppression ≤ 2 ms P1 = 1 input filter off (default settings)

Function

The AS-Interface I/O module VBA-4E4A-KE-ZEJQ/E2L is a control cabinet module with 4 inputs and 3 electronic outputs. The housing is only 22.5 mm wide and takes up little space in the control cabinet. The module is mounted by snapping onto the 35-mm DIN rail in compliance with EN 50022.

The connection is made via plug-in terminals. Four-terminal blocks (black) are used for the inputs. The connection of the outputs, the external bulk power and the AS-Interface is via 2-terminal blocks (output black, bulk power grey, AS-Interface yellow).

The supply to the inputs and the connected sensors can be fed either from the internal supply of the module (from the AS-Interface) or via an external voltage source. A switch located on the side of the module changes the supply source. The choice of internal input supply is displayed via the INT LED. The IN and OUT LEDs display the current switching status of the relevant inputs and outputs. The OUT LED also indicates an overload or a lead breakage at the associated output.

Note:

The device is equipped with a communication monitor, which deactivates the outputs if the AS-Interface does not communicate with the module for more than 40 ms. The communication monitor can be deactivated via the parameter P0. Filters that suppress pulses with a duration of 2 ms or less at the inputs can be connected via the parameter P1. Parameter P2 activates a lead breakage detection system for the outputs. This function detects and reports a missing load, providing the relevant output is deactivated. The associated OUT LED and the 'peripheral fault' function display the signal transmitted to the AS-Interface master. A signal indicating an overload of the internal input supply or the outputs is also transmitted to the AS-Interface master via the 'peripheral fault' function. Communication via the AS-Interface continues even if a peripheral fault is set.

Accessories

VBP-HH1-V3.0-KIT

AS-Interface Handheld with accessory

VBP-HH1-V3.0

AS-Interface Handheld

VAZ-PK-1,5M-V1-G

Adapter cable module/hand-held programming device

P2	Lead breakage outputs P2 = 0 lead breakage on P2 = 1 lead breakage off (default settings)
P3	not used
Ambient conditions	
Ambient temperature	-25 ... 60 °C (-13 ... 140 °F)
Storage temperature	-25 ... 85 °C (-13 ... 185 °F)
Relative humidity	85 % , noncondensing
Climatic conditions	For indoor use only
Altitude	≤ 2000 m above MSL
Pollution degree	2
Mechanical specifications	
Degree of protection	IP20
Connection	removable terminals rated connection capacity: rigid/flexible (with and without wire-end ferrules): 0.25 mm ² ... 2.5 mm ² for multiple-wire connection with two wires of equal cross-section: flexible with twin wire-end ferrules: 0.5 mm ² ... 1.5 mm ²
Material	
Housing	PA 66-FR
Mass	150 g
Mounting	DIN mounting rail
Tightening torque of clamping screws	0.5 Nm ... 0.6 Nm

Notes

Do not connect inputs and outputs, which are supplied via the module from AS-interface or via auxiliary power, with power supply and signal circuits with external potentials.



SCATTERGOOD & JOHNSON LTD

ELECTRICAL ENGINEERING & FLUID CONTROL DISTRIBUTORS

Est.1899

At Scattergood & Johnson Ltd, we pride ourselves on being a technical distributor to specialist industries.

Working with a range of quality product suppliers across a number of specialist markets, we are not your average 'box shifter' - we are your technical and supply chain partner.

We fully support every product we sell - for free! Our internal team and external sales engineers can answer any product or application question, no matter the complexity.

Backing up this technical ability is a range of 50,000+ products available from stock for nationwide next day delivery (same day if required!), or you can collect what you need from any of our trade counters around the UK.

Select your specialist interest below to learn more about how we can help.



Online, In Branch and On the Road - Scattergood & Johnson Ltd, there when you need us.

www.scatts.co.uk