

LRD3●● / LRD3●●3 / LRD3●●L

LRD3●●L3 / LR3D3●● / LR3D3●●3

www.schneider-electric.com

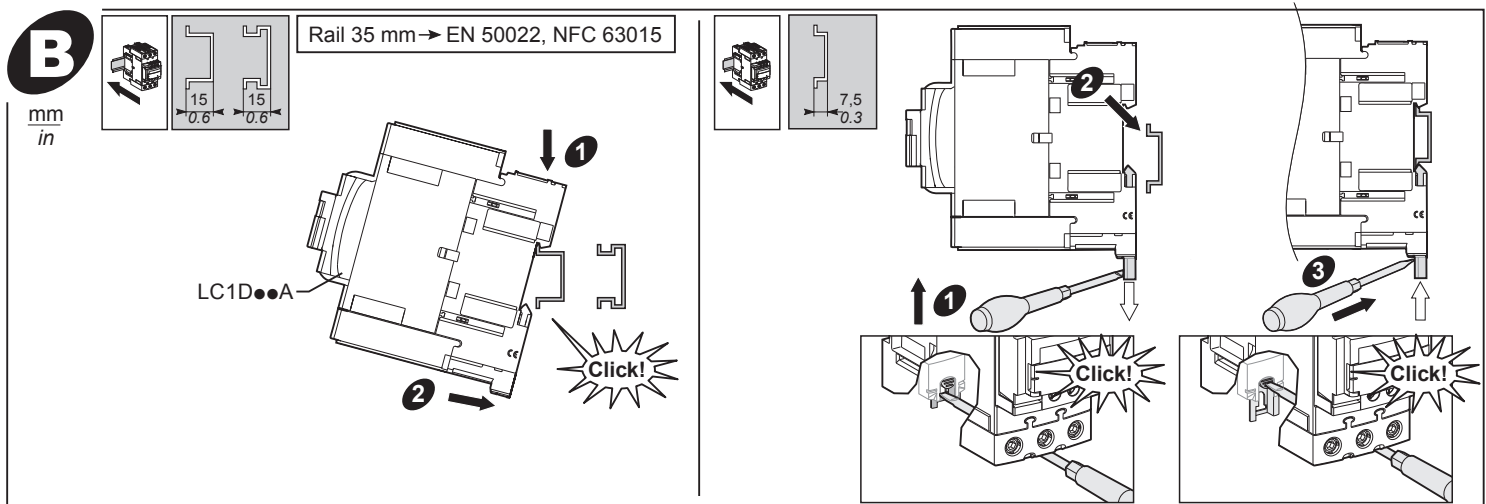
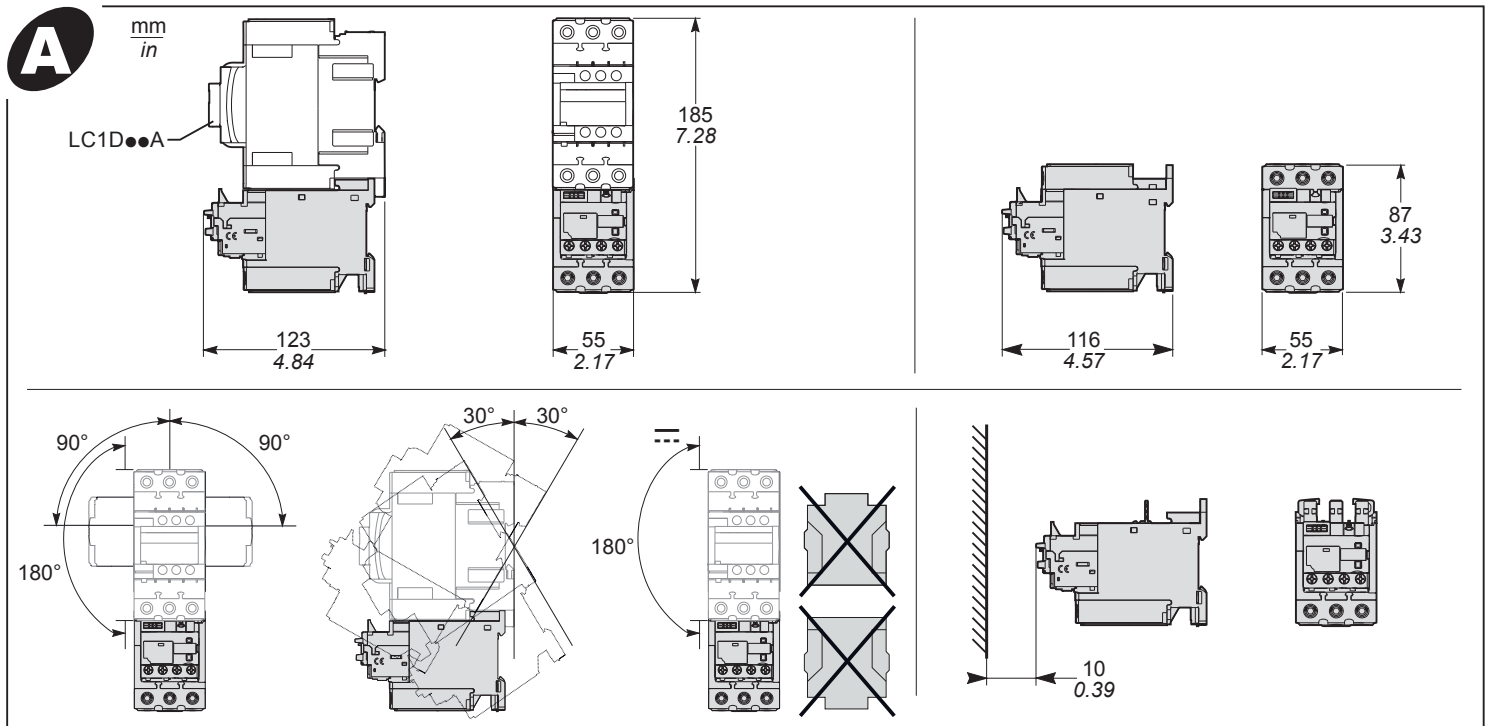
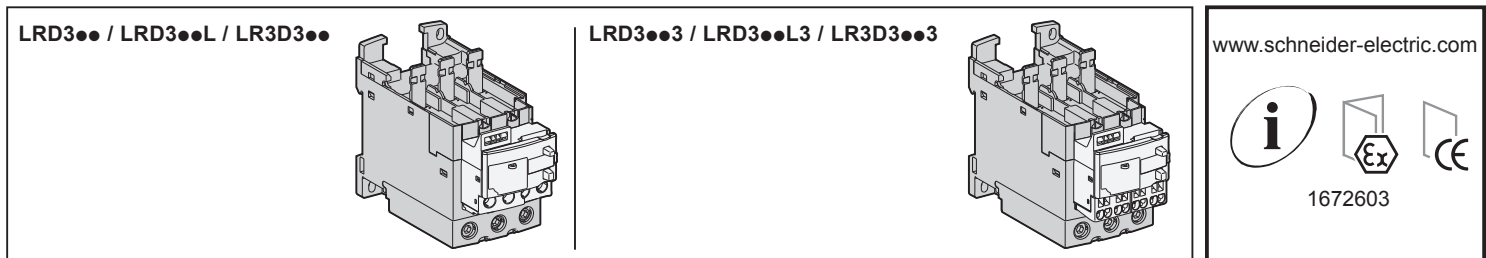

⚠ ⚠ DANGER / DANGER / PELIGRO / GEFAHR / PERICOLO / PERIGO / 危險 / ОПАСНО			
<p>HAZARD OF ELECTRIC SHOCK, EXPLOSION, OR ARC FLASH Disconnect all power before servicing equipment. Failure to follow these instructions will result in death or serious injury.</p>	<p>RISQUE D'ÉLECTROCUTION, D'EXPLOSION OU D'ARC ÉLECTRIQUE Coupez toutes les alimentations avant de travailler sur cet appareil. Le non-respect de ces instructions provoquera la mort ou des blessures graves.</p>	<p>PELIGRO DE DESCARGA ELÉCTRICA, EXPLOSIÓN O ARCO ELÉCTRICO Desconecte todas las alimentaciones antes de manipular el producto. Si no se siguen estas instrucciones provocará lesiones graves o incluso la muerte.</p>	<p>GEFAHR VON ELEKTRISCHEM SCHLAG, EXPLOSION ODER LICHTBOGEN Vor dem Arbeiten am Gerät alle Spannungsversorgungen abschalten. Die Nichtbeachtung dieser Anweisungen führt zu Tod oder schwerer Körperverletzung.</p>
<p>RISCHIO DI SCARICA ELETTRICA, ESPLOSIONE O ARCO ELETTRICO Scollegare l'apparecchio da tutti i circuiti di alimentazione prima di qualsiasi intervento. Il mancato rispetto di queste istruzioni provocherà morte o gravi infortuni.</p>	<p>RISCO DE ELECTROCUSSÃO, DE EXPLOSIÃO, OU DE ARCO ELÉCTRICO Desconecte todas as alimentações antes de manipular o produto. A não observância destas instruções resultará em morte, ou ferimentos graves.</p>	<p>可能有触电、爆炸或者电弧灼伤的危險 在此电力设备上工作时,请先切断所有电源 若违背这些说明,则可能会导致严重的人身伤害甚至死亡</p>	<p>Опасность поражением электрическим током, опасность взрыва или вспышки дуги. Перед обслуживанием или ремонтом убедитесь, что питание отключено. Несоблюдение этих инструкций приведет к смерти или серьезной травме.</p>

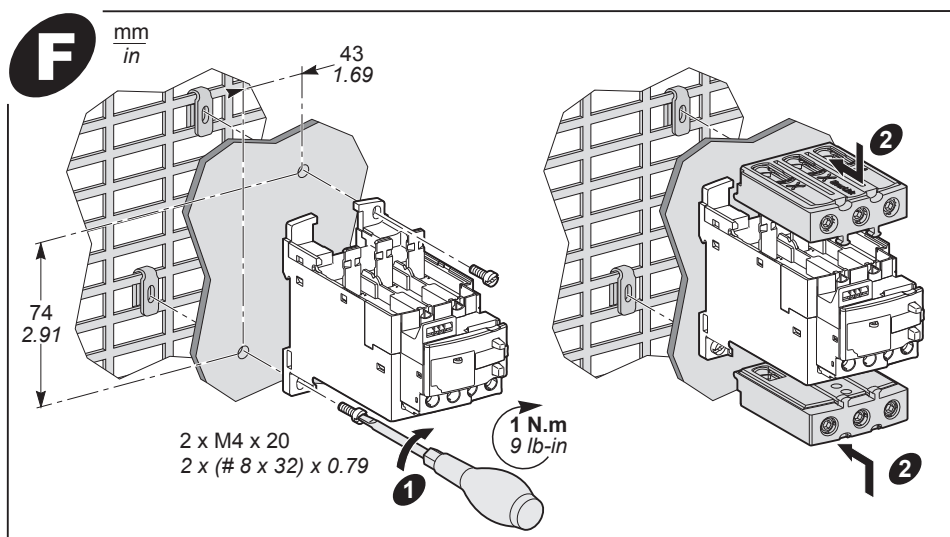
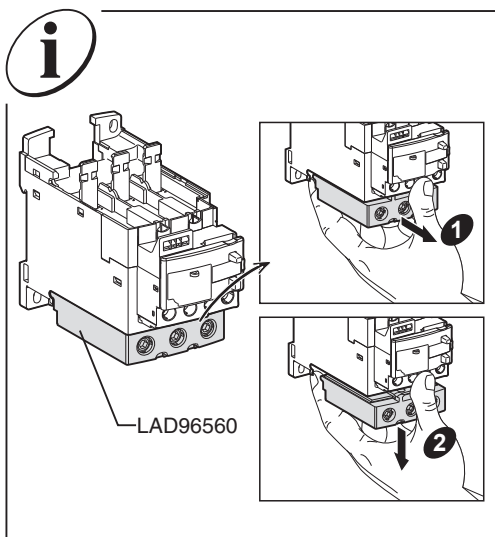
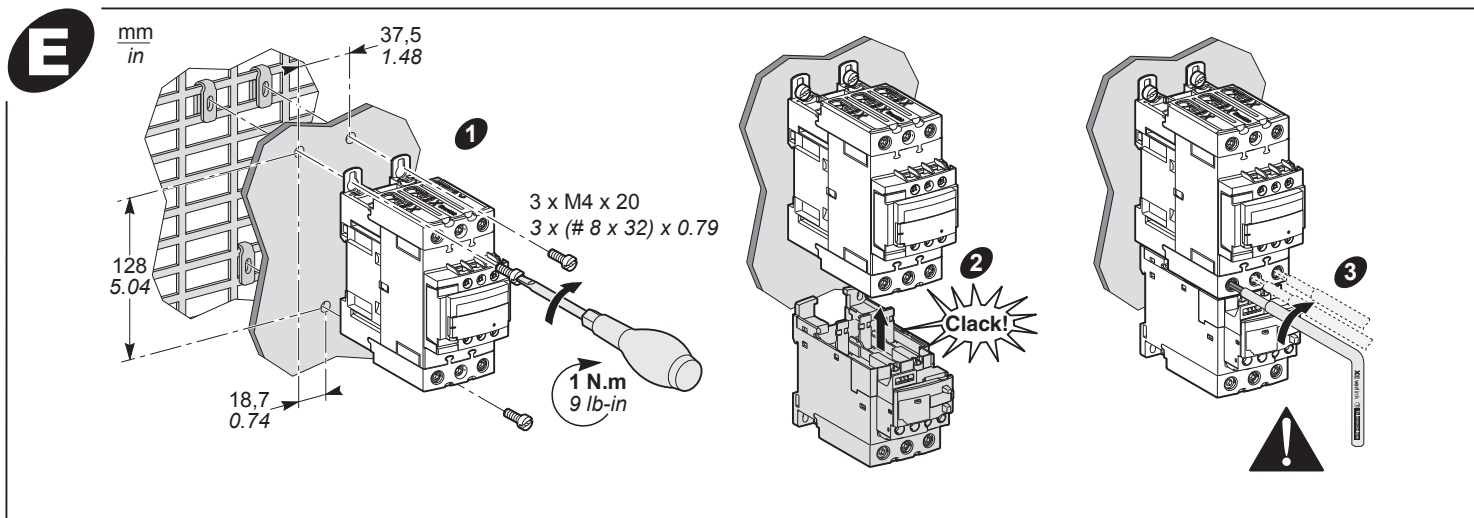
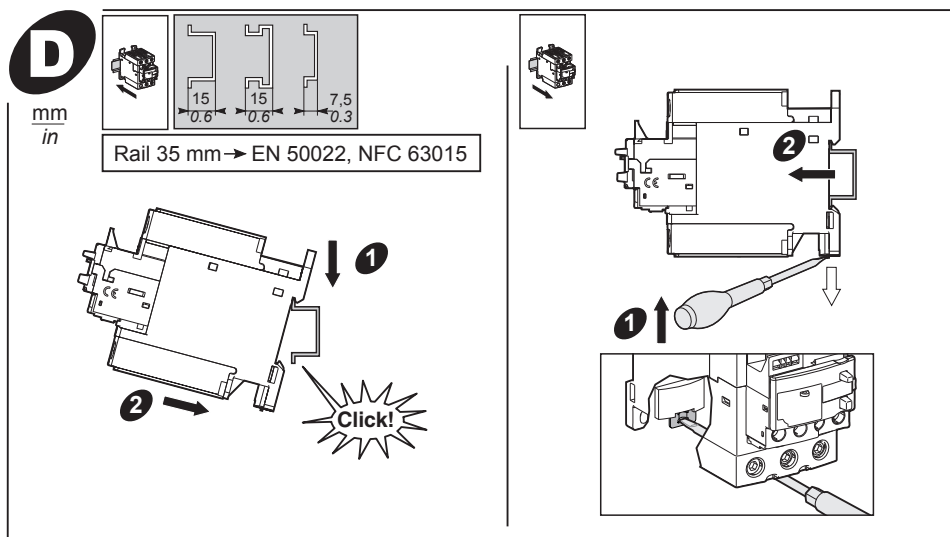
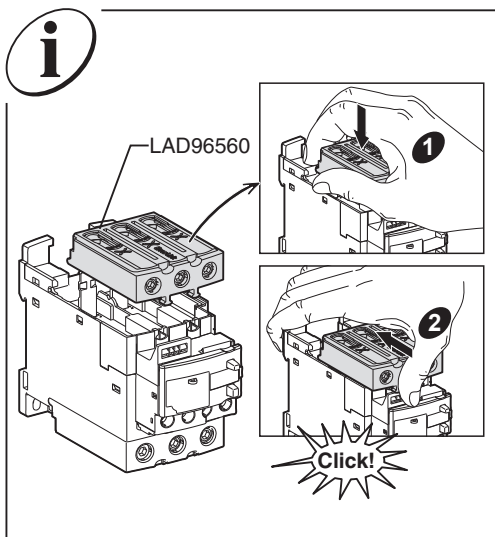
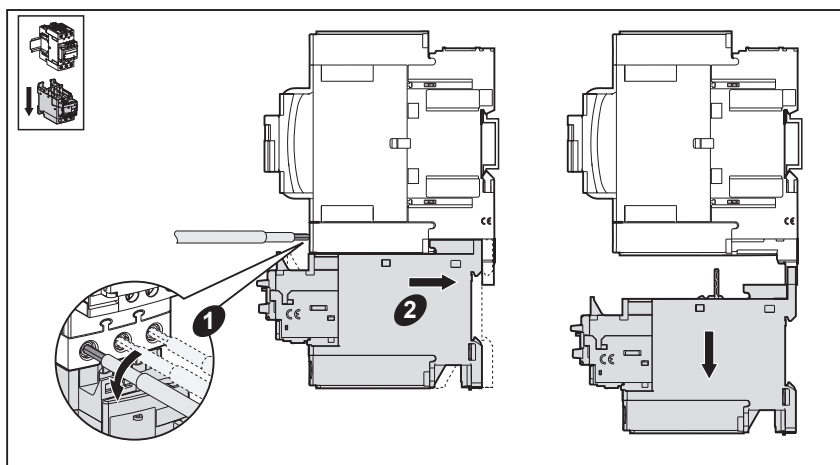
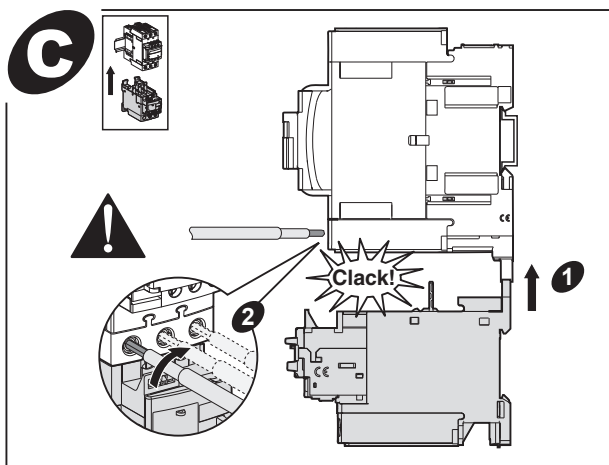

G LRD3●● / LRD3●●L / LR3D3●●

LAD 703●

H LRD3●● / LRD3●●L / LR3D3●●

LA7 D305

I

XB5 AL84101

J

XB5 AA86102

K

Reset { Auto [] Man. []
Test []
Stop []

L

16 mm	1...25 mm ²	2 x 1...25 mm ²						5 N.m		LADALLEN4
16 mm	35 mm ²	1 x 1...25 mm ² + 1 x 35 mm ²						8 N.m		4 mm
0.63 in.	AWG 18...2	1 x AWG 18...4 + 1 x AWG 18...2						70 lb-in		

LADALLEN4

M

LRD3●● LRD3●●L LR3D3●●											
	10 mm	1...2,5 mm ²	1...2,5 mm ²	1...2,5 mm ²	1...2,5 mm ²	1...2,5 mm ²	1...2,5 mm ²	1,7 N.m			
	0.4 in.	AWG 18...14	AWG 18...14	AWG 18...14	AWG 18...14	AWG 18...14	AWG 18...14	15 lb-in			PH 2

N

LRD3●●3 LRD3●●L3 LR3D3●●3											
		1...2,5 mm ²						Ø 3,5 mm			
		AWG 18...14						0.14 in.			

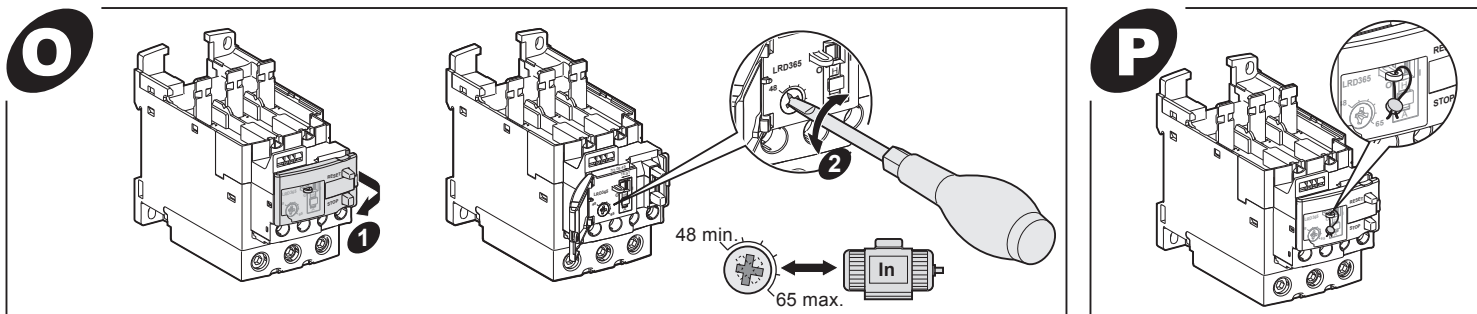

Q	Man. (for manual)	Man. (pour manuel)	Man. (manual)	Man. (für manuell)	Man. (manuale)	Man. (para manual)	手动 (表示手动)	Руч. (вручную)
	Auto (for automatic)	Auto (matique)	Auto(mático)	Auto(matisch)	Auto(matico)	Auto (para automático)	自动 (表示自动)	Авто (автоматический)

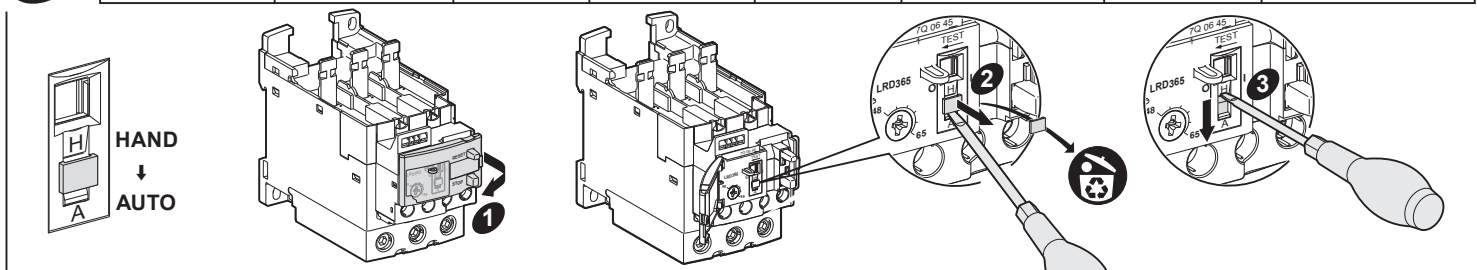

WARNING / AVERTISSEMENT / ADVERTENCIA / WARNUNG / AVVERTIMENTO / ATENÇÃO / 警告 / ПРЕДУПРЕЖДЕНИЕ

<p>AUTOMATIC START HAZARD Motor connected to the circuit may start automatically in auto restart position. Failure to follow these instructions can result in death, serious injury, or equipment damage.</p>	<p>RISQUE DE DÉMARRAGE AUTOMATIQUE En mode de redémarrage automatique, il est possible que le moteur connecté au circuit démarre automatiquement. Le non-respect de ces instructions peut provoquer la mort, des blessures graves ou des dommages matériels.</p>	<p>PELIGRO DE ARRANQUE AUTOMÁTICO Un motor conectado al circuito puede arrancar automáticamente cuando esté en la posición de rearranque automático. Si no se siguen estas instrucciones pueden producirse lesiones personales graves o mortales o daños en el equipo.</p>	<p>GEFAHR EINES AUTOMATISCHEN STARTS Der an den Stromkreis angeschlossene Motor könnte in der Position für automatischen Neustart automatisch starten. Die Nichtbeachtung dieser Anweisungen kann Tod, schwere Körperverletzung oder Sachschäden zur Folge haben.</p>
<p>PERICOLO AVVIO AUTOMATICO Il motore connesso al circuito può avviarsi automaticamente se in posizione riavvio automatico. Il mancato rispetto delle istruzioni può causare la morte, gravi ferite o danni all'attrezzatura.</p>	<p>PERIGO DE ARRANQUE AUTOMÁTICO O motor ligado ao circuito pode arrancar automaticamente na posição de rearranque automático. O não cumprimento destas instruções pode provocar danos no equipamento, ferimentos graves ou a morte.</p>	<p>自动启动危险 连接到电路中的电动机可能会在自动重新启动位置中自动重新启动。 如果不遵守这些要求，可能会导致死亡、严重的人身伤害或损坏设备。</p>	<p>ОПАСНОСТЬ АВТОМАТИЧЕСКОГО ЗАПУСКА Двигатель, подключенный к контуру, может запуститься автоматически в положении автоматического перезапуска. Неследование этим инструкциям может привести к смерти, серьезным травмам или повреждению оборудования.</p>

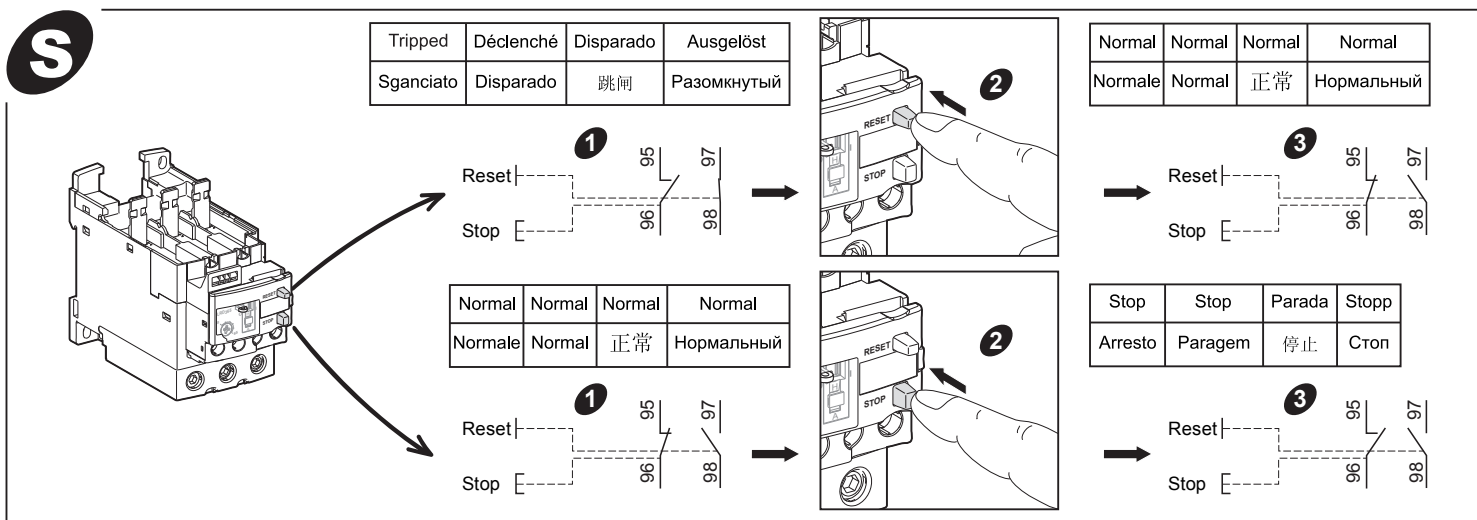
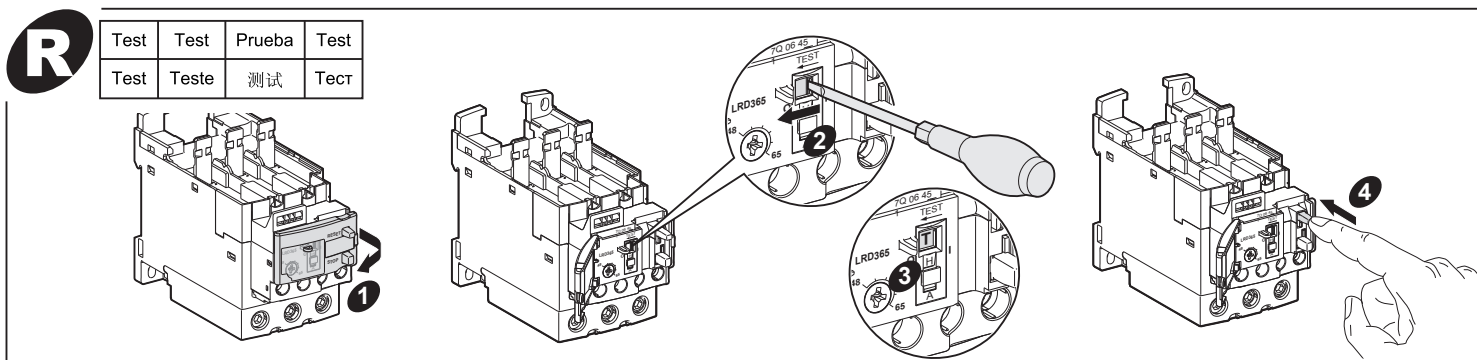

**WARNING / AVERTISSEMENT / ADVERTENCIA / WARNUNG /
AVVERTIMENTO / ATENÇÃO / 警告 / ПРЕДУПРЕЖДЕНИЕ**
RISK OF FIRE OR ELECTRIC SHOCK (FOR DEVICE WITH UL HI-FAULT SHORT CIRCUIT CURRENT RATINGS ONLY)

■ The opening of the branch-circuit protective device may be an indication that a fault current has been interrupted.
 ■ To reduce the risk of fire or electric shock, current-carrying parts and the other components of the controller should be examined and replaced if damaged.
Failure to follow these instructions can result in death, serious injury, or equipment damage.

RISQUE D'INCENDIE OU D'ELECTROCUTION (POUR APPAREIL AYANT DES COURANTS DE COURT-CIRCUIT ASSIGNES UL TRES ELEVES UNIQUEMENT)

■ L'ouverture du dispositif de protection du circuit de dérivation peut indiquer qu'un courant de défaut a été interrompu.
 ■ Pour réduire le risque d'incendie ou d'électrocution, les parties sous tension et les autres composants du contrôleur doivent être examinés et remplacés en cas de dommage.
Le non-respect de ces instructions peut provoquer la mort, des blessures graves ou des dommages matériels.

RIESGO DE INCENDIO O ELECTROCUCIÓN (SOLO PARA EL DISPOSITIVO CON CORRIENTES DE CORTOCIRCUITO ASIGNADAS UL MUY ELEVADAS)

■ La abertura del dispositivo de protección del circuito de derivación puede indicar que una corriente de fallo ha sido interrumpida.
 ■ Para reducir el riesgo de incendio o electrocución, las partes bajo tensión y los demás componentes del circuito deben ser examinados y sustituidos en caso de dañarse.
Si no se siguen estas instrucciones pueden producirse lesiones personales graves o mortales o daños en el equipo.

BRAND- ODER STROMSCHLAGGEFAHR (NUR BEI GERÄTEN MIT KURZSCHLUSSFESTIGKEIT BEI HOHEM FEHLERSTROM NACH UL-STANDARD)

■ Das Öffnen der Schutzvorrichtung des Zweigstromkreises kann ein Hinweis darauf sein, dass ein Fehlerstrom unterbrochen wurde.
 ■ Um die Brand- oder Stromschlaggefahr zu mindern, sollten stromführende Bauteile sowie die anderen Komponenten des Steuergeräts überprüft und bei Beschädigung ausgetauscht werden.
Die Nichtbeachtung dieser Anweisungen kann Tod, schwere Verletzungen oder Sachschäden zur Folge haben.

RISCHIO DI INCENDIO O SCARICA ELETTRICA (SOLO PER DISPOSITIVO CERTIFICATO UL CON SCCL AD ALTA CORRENTE DI GUASTO)

■ L'apertura del dispositivo di protezione del circuito derivato può indicare un'interruzione della corrente di guasto.
 ■ Per ridurre il rischio di incendio o scarica elettrica, è necessario esaminare le parti in cui al momento passa la corrente e gli altri componenti del controllore e sostituirli se sono danneggiati.
Il mancato rispetto di queste istruzioni può provocare morte, gravi infortuni o danni alle apparecchiature.

RISCO DE INCÊNDIO OU ELETROCUSSÃO (PARA DISPOSITIVO COM ALTO VALOR NOMINAL DE CORRENTE DE CURTO-CIRCUITO DE FALTA UNICAMENTE)

■ A abertura do dispositivo de proteção do circuito derivado pode ser uma indicação de que uma corrente de falta foi interrompida.
 ■ Para reduzir o risco de incêndio ou eletrocussão, as partes condutoras de corrente e os outros componentes do controlador devem ser examinados e substituídos se estiverem deteriorados.
A não observância destas instruções pode provocar a morte, ferimentos graves, ou danos no equipamento.

有火灾或电击危险（仅当设备具有超高故障短路电流额定值时）

■ 分支电流保护装置断开可能表明某故障电流已被切断。
 ■ 为减少火灾或电弧烧伤的危险，应经常检查和更换（如损坏）控制器的带电部分及其它部件。
不遵循上述说明可能导致人员伤亡或设备损坏。

ОПАСНОСТЬ ВОЗНИКНОВЕНИЯ ПОЖАРА ИЛИ УДАРА ЭЛЕКТРИЧЕСКИМ ТОКОМ (ТОЛЬКО ДЛЯ УСТРОЙСТВА С ВЫСОКИМ НОМИНАЛОМ ТОКА КОРОТКОГО ЗАМЫКАНИЯ СОГЛАСНО UL)

■ Срабатывание расцепителя устройства защитного отключения групповой цепи может являться признаком наличия тока утечки.
 ■ Для снижения риска возникновения пожара или поражения электрическим током токоведущие части и другие детали контроллера следует регулярно проверять и заменять в случае повреждения.
Несоблюдение этих инструкций может привести к смерти, серьезной травме или повреждению оборудования.

产品中有毒有害物质或元素的名称及含量
Contents of Toxic or Hazardous Substances or Elements

部件名称 Part Name	有毒有害物质或元素 Toxic or hazardous Substances and Elements					
	铅 (Pb)	汞 (Hg)	镉 (Cd)	六价铬 (Cr ⁶⁺)	多溴联苯 (PBB)	多溴二苯醚 (PBDE)
金属部件 Metal Parts	X	O	O	O	O	O

O : 表示该有毒有害物质在该部件所有均质材料中的含量均在 SJ/T11363-2006 标准规定的限量要求以下。
 Indicates that this toxic or hazardous substance contained in all of the homogeneous materials for this part is below the limit requirement in SJ/T11363-2006.

X : 表示该有毒有害物质至少在该部件的某一均质材料中的含量超出 SJ/T11363-2006 标准规定的限量要求。
 Indicates that this toxic or hazardous substance contained in at least one of the homogeneous materials used for this part is above the limit requirement in SJ/T11363-2006.

对销售之日的所售产品，本表显示，施耐德电气供应链的电子产品信息产品可能包含这些物质。注意：在所售产品中可能会也可能不会含有所有列出的部件。
 Note: The products on sale may or may not contain all the parts/components listed here.

Schneider Electric Industries SAS

35, rue Joseph Monier
 CS 30323
 F - 92506 Rueil Malmaison Cedex
 www.schneider-electric.com

http://www.schneider-electric.com

Уполномоченный поставщик в РФ: ЗАО «Шнейдер Электрик» Адрес: 127018, г. Москва, ул. Двинцев, д.12, корп.1, тел. +7 (495)777 99 88, факс: +7 (495)777 99 94, 8-800-200-6446 www.schneider-electric.ru	
Only for models bearing these marks	



SCATTERGOOD & JOHNSON LTD

ELECTRICAL ENGINEERING & FLUID CONTROL DISTRIBUTORS

Est.1899

At Scattergood & Johnson Ltd, we pride ourselves on being a technical distributor to specialist industries.

Working with a range of quality product suppliers across a number of specialist markets, we are not your average 'box shifter' - we are your technical and supply chain partner.

We fully support every product we sell - for free! Our internal team and external sales engineers can answer any product or application question, no matter the complexity.

Backing up this technical ability is a range of 50,000+ products available from stock for nationwide next day delivery (same day if required!), or you can collect what you need from any of our trade counters around the UK.

Select your specialist interest below to learn more about how we can help.



Online, In Branch and On the Road - Scattergood & Johnson Ltd, there when you need us.

www.scatts.co.uk