

Data sheet

OMNIMATE Signal - series LSF LSF-SMT 5.08/04/180 3.5SN BK TU

Weidmüller Interface GmbH & Co. KG
Klingenbergstraße 26
D-32758 Detmold
Germany
Fon: +49 5231 14-0
Fax: +49 5231 14-292083
www.weidmueller.com

Product image

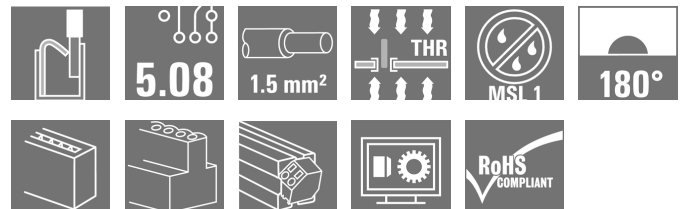

Similar to illustration

PCB terminal for fully automatic assembly in reflow soldering (SMT), with Push In conductor connection system. Conductor inserted and slider operated in same direction (TOP). Packed in box or as tape on reel. Pin lengths optimised at 1.5 mm or 3.5 mm.

General ordering data

| | |
|--------------|---|
| Type | LSF-SMT 5.08/04/180 3.5SN BK TU |
| Order No. | 1826070000 |
| Version | Printed circuit board terminals, 5.08 mm, Number of poles: 4, 180°, Solder pin length (l): 3.5 mm, black, PUSH IN, Clamping range, max.: 1.5 mm ² , Tube |
| GTIN (EAN) | 4032248328789 |
| Qty. | 28 pc(s). |
| Product data | IEC: 500 V / 17.5 A / 0.2 - 1.5 mm ² UL: 300 V / 12 A / AWG 28 - AWG 14 |
| Packaging | Tube |

Creation date 21 April 2020 16:51:18 CEST

Data sheet

OMNIMATE Signal - series LSF LSF-SMT 5.08/04/180 3.5SN BK TU

Weidmüller Interface GmbH & Co. KG
Klingenbergstraße 26
D-32758 Detmold
Germany
Fon: +49 5231 14-0
Fax: +49 5231 14-292083
www.weidmueller.com

Technical data

Dimensions and weights

| | | | |
|--------------------------|------------|-----------------|------------|
| Width | 19.44 mm | Width (inches) | 0.765 inch |
| Height | 17.5 mm | Height (inches) | 0.689 inch |
| Height of lowest version | 14 mm | Depth | 7.8 mm |
| Depth (inches) | 0.307 inch | Net weight | 2.46 g |

System parameters

| | | | |
|--|------------------------------|--|------------------------|
| Product family | OMNIMATE Signal - series LSF | Wire connection method | PUSH IN |
| Mounting onto the PCB | THT/THR solder connection | Conductor outlet direction | 180° |
| Pitch in mm (P) | 5.08 mm | Pitch in inches (P) | 0.2 inch |
| Number of poles | 4 | Fitted by customer | No |
| Solder pin length (l) | 3.5 mm | Solder pin length tolerance | +0.1 / -0.3 mm |
| Solder pin dimensions | 0.35 x 0.8 mm | Solder pin dimensions = d tolerance | 0 / -0.1 mm |
| Solder eyelet hole diameter (D) | 1.1 mm | Solder eyelet hole diameter tolerance (D) | + 0,1 mm |
| Number of solder pins per pole | 2 | Stripping length | 8 mm |
| L1 in mm | 15.24 mm | L1 in inches | 0.6 inch |
| Touch-safe protection acc. to DIN VDE 0470 | IP 20 | Touch-safe protection acc. to DIN VDE 57 106 | Safe from finger touch |
| Volume resistance | 1.60 mΩ | | |

Material data

| | | | |
|---------------------------------------|--------------|---------------------------------------|---------------------|
| Insulating material | LCP GF | Colour | black |
| Colour of operational elements | white | Material of operational elements | PPA GF |
| Colour chart (similar) | RAL 9011 | Insulating material group | Illa |
| Comparative Tracking Index (CTI) | ≥ 175 | Insulation strength | ≥ 10 ⁸ Ω |
| Moisture Level (MSL) | 1 | UL 94 flammability rating | V-0 |
| Contact material | Copper alloy | Layer structure of solder connection | 4-6 μm Sn matt |
| Storage temperature, min. | -25 °C | Storage temperature, max. | 50 °C |
| Max. relative humidity during storage | 70 % | Operating temperature, min. | -50 °C |
| Operating temperature, max. | 120 °C | Temperature range, installation, min. | -30 °C |
| Temperature range, installation, max. | 120 °C | | |

Conductors suitable for connection

| | |
|---|----------------------|
| Clamping range, min. | 0.13 mm ² |
| Clamping range, max. | 1.5 mm ² |
| Wire connection cross section AWG, min. | AWG 28 |
| Wire connection cross section AWG, max. | AWG 14 |
| Solid, min. H05(07) V-U | 0.2 mm ² |
| Solid, max. H05(07) V-U | 1.5 mm ² |
| Flexible, min. H05(07) V-K | 0.2 mm ² |
| Flexible, max. H05(07) V-K | 1.5 mm ² |
| w. plastic collar ferrule, DIN 46228 pt 4, min. | 0.25 mm ² |
| w. plastic collar ferrule, DIN 46228 pt 4, max. | 0.75 mm ² |
| w. wire end ferrule, DIN 46228 pt 1, min. | 0.25 mm ² |
| w. wire end ferrule, DIN 46228 pt 1, max. | 1.5 mm ² |

Creation date 21 April 2020 16:51:18 CEST

Catalogue status 17.04.2020 / We reserve the right to make technical changes.

Data sheet

OMNIMATE Signal - series LSF LSF-SMT 5.08/04/180 3.5SN BK TU

Weidmüller Interface GmbH & Co. KG
Klingenbergstraße 26
D-32758 Detmold
Germany
Fon: +49 5231 14-0
Fax: +49 5231 14-292083
www.weidmueller.com

Technical data

| | | | |
|---------------------|--|------------------------------|-------------------------------|
| Clampable conductor | Cross-section for conductor connection | Type | fine-wired |
| | | nominal | 0.25 mm ² |
| wire end ferrule | | Stripping length | nominal 10 mm |
| | | Recommended wire-end ferrule | H0,25/12 HBL |
| Clampable conductor | Cross-section for conductor connection | Type | fine-wired |
| | | nominal | 0.34 mm ² |
| wire end ferrule | | Stripping length | nominal 10 mm |
| | | Recommended wire-end ferrule | H0,34/12 TK |
| Clampable conductor | Cross-section for conductor connection | Type | fine-wired |
| | | nominal | 0.5 mm ² |
| wire end ferrule | | Stripping length | nominal 10 mm |
| | | Recommended wire-end ferrule | H0,5/14 OR |
| Clampable conductor | Cross-section for conductor connection | Type | fine-wired |
| | | nominal | 0.75 mm ² |
| wire end ferrule | | Stripping length | nominal 10 mm |
| | | Recommended wire-end ferrule | H0,75/14T HBL |
| Clampable conductor | Cross-section for conductor connection | Type | fine-wired |
| | | nominal | 1.5 mm ² |
| wire end ferrule | | Stripping length | nominal 7 mm |
| | | Recommended wire-end ferrule | H1,5/7 |
| Reference text | Length of ferrules is to be chosen depending on the product and the rated voltage., The outside diameter of the plastic collar should not be larger than the pitch (P) | | |
| Max. clamping range | 1.5 mm ² | | |

Rated data acc. to IEC

| | | | |
|---|------------------------|---|------------------|
| tested acc. to standard | IEC 60664-1, IEC 61984 | Rated current, min. number of poles (Tu=20°C) | 17.5 A |
| Rated current, max. number of poles (Tu=20°C) | 17.5 A | Rated current, min. number of poles (Tu=40°C) | 17.5 A |
| Rated current, max. number of poles (Tu=40°C) | 15 A | Rated voltage for surge voltage class / pollution degree II/2 | 500 V |
| Rated voltage for surge voltage class / pollution degree III/2 | 320 V | Rated voltage for surge voltage class / pollution degree III/3 | 250 V |
| Rated impulse voltage for surge voltage class/ pollution degree II/2 | 4 kV | Rated impulse voltage for surge voltage class/ pollution degree III/2 | 4 kV |
| Rated impulse voltage for surge voltage class/ contamination degree III/3 | 4 kV | Short-time withstand current resistance | 3 x 1s with 80 A |

Rated data acc. to CSA

| | | | |
|-----------------------------------|---|-----------------------------------|----------------|
| Institute (CSA) |  | Certificate No. (CSA) | 200039-1664286 |
| Rated voltage (Use group B / CSA) | 300 V | Rated voltage (Use group D / CSA) | 300 V |
| Rated current (Use group B / CSA) | 10 A | Rated current (Use group D / CSA) | 10 A |
| Wire cross-section, AWG, min. | AWG 28 | Wire cross-section, AWG, max. | AWG 14 |
| Reference to approval values | Specifications are maximum values, details - see approval certificate. | | |

Creation date 21 April 2020 16:51:18 CEST

Catalogue status 17.04.2020 / We reserve the right to make technical changes.

Data sheet

OMNIMATE Signal - series LSF LSF-SMT 5.08/04/180 3.5SN BK TU

Weidmüller Interface GmbH & Co. KG
Klingenbergstraße 26
D-32758 Detmold
Germany
Fon: +49 5231 14-0
Fax: +49 5231 14-292083
www.weidmueller.com

Technical data

Rated data acc. to UL 1059

Institute (cURus)



Certificate No. (cURus)

E60693

Rated voltage (Use group B / UL 1059) 300 V

Rated voltage (Use group D / UL 1059) 300 V

Rated current (Use group B / UL 1059) 12 A

Rated current (Use group D / UL 1059) 10 A

Wire cross-section, AWG, min. AWG 28

Wire cross-section, AWG, max. AWG 14

Reference to approval values

Specifications are
maximum values, details -
see approval certificate.

Packing

Packaging Tube

VPE length 15 mm

VPE width 20 mm

VPE height 550 mm

Surface resistance $R_s = 10^9 - 10^{12} \Omega$

Classifications

ETIM 6.0

EC002643

ETIM 7.0

EC002643

eClass 9.0

27-44-04-01

eClass 9.1

27-44-04-01

eClass 10.0

27-44-04-01

UNSPSC

30-21-18-01

Notes

Notes

- Additional push button colours on request
- Operating force of slider max. 40 N
- Rated current related to rated cross-section & min. No. of poles.
- Wire end ferrule with plastic collar to DIN 46228/4
- Wire end ferrule without plastic collar to DIN 46228/1
- P on drawing = pitch
- Rated data refer only to the component itself. Clearance and creepage distances to other components are to be designed in accordance with the relevant application standards.
- Crimping shape "A" for wire end ferrules with PZ 6/5 crimping tool recommended.

IPC conformity

Conformity: The products are developed, manufactured and delivered according international recognized standards and norms and comply with the assured properties in the data sheet resp. fulfill decorative properties in accordance with IPC-A-610 "Class 2". Further claims on the products can be evaluated on request.

Approvals

Approvals



ROHS

Conform

Creation date 21 April 2020 16:51:18 CEST

Catalogue status 17.04.2020 / We reserve the right to make technical changes.

Data sheet

OMNIMATE Signal - series LSF LSF-SMT 5.08/04/180 3.5SN BK TU

Weidmüller Interface GmbH & Co. KG
Klingenbergstraße 26
D-32758 Detmold
Germany
Fon: +49 5231 14-0
Fax: +49 5231 14-292083
www.weidmueller.com

Technical data

Downloads

| | |
|---|---|
| Approval/Certificate/Document of Conformity | Declaration of the Manufacturer |
| Brochure/Catalogue | FL DRIVES EN FL ANALO.SIGN.CONV. EN MB SMT EN FL DRIVES DE MB DEVICE MANUF. EN CAT 2 PORTFOLIOGUIDE EN FL BUILDING SAFETY EN FL APPL LED LIGHTING EN FLIndustr.CONTROLS EN FL MACHINE SAFETY EN FL HEATING ELECTR EN FL APPL_INVERTER EN FL_BASE_STATION_EN FL ELEVATOR EN FL POWER SUPPLY EN FL 72H SAMPLE SER EN PO OMNIMATE EN |
| Engineering Data | EPLAN, WSCAD |
| Engineering Data | LSF-SMT.zip STEP |
| White paper surface mount technology | Download Whitepaper |

Data sheet

OMNIMATE Signal - series LSF
LSF-SMT 5.08/04/180 3.5SN BK TU

Weidmüller Interface GmbH & Co. KG
 Klingenbergstraße 26
 D-32758 Detmold
 Germany
 Fon: +49 5231 14-0
 Fax: +49 5231 14-292083
 www.weidmueller.com

Drawings

Dimensional drawing

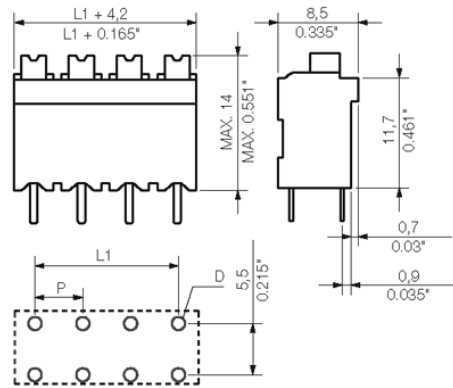

Graph

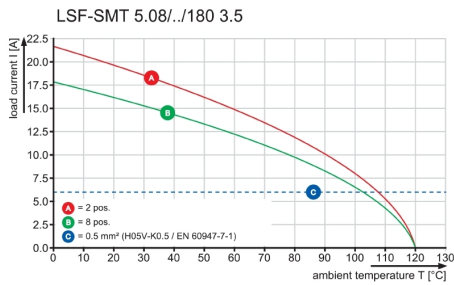

Graph

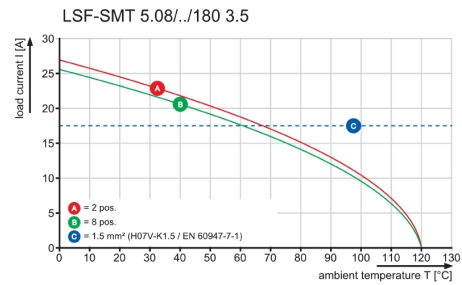

The reproduction, distribution and utilization of this document as well as the communication of its contents to others without explicit authorization is prohibited. Offenders will be held liable for the payment of damages. Weidmüller exclusively reserves the right to file for patents, utility models or designs.

© Weidmüller Interface GmbH & Co. KG

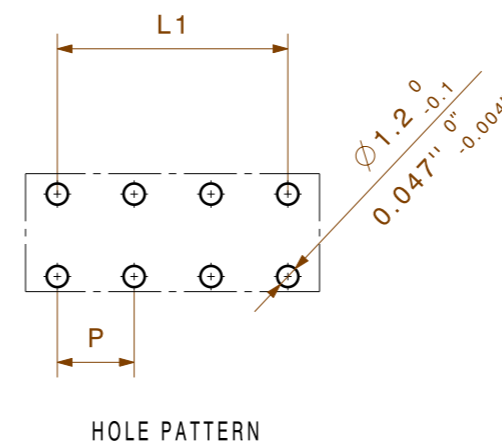
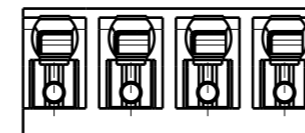
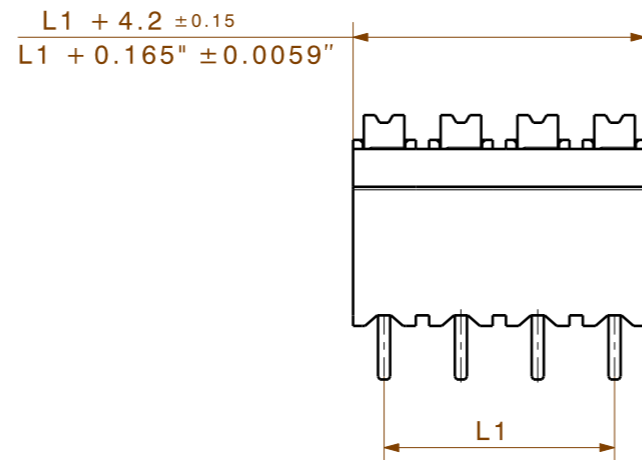

P=5.08

SHOWN: LSF-SMT 5.08/04/180

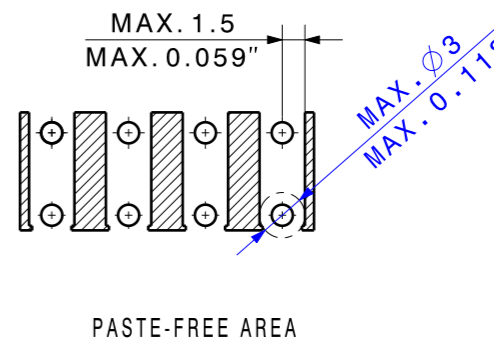
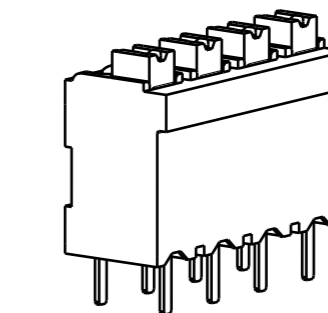
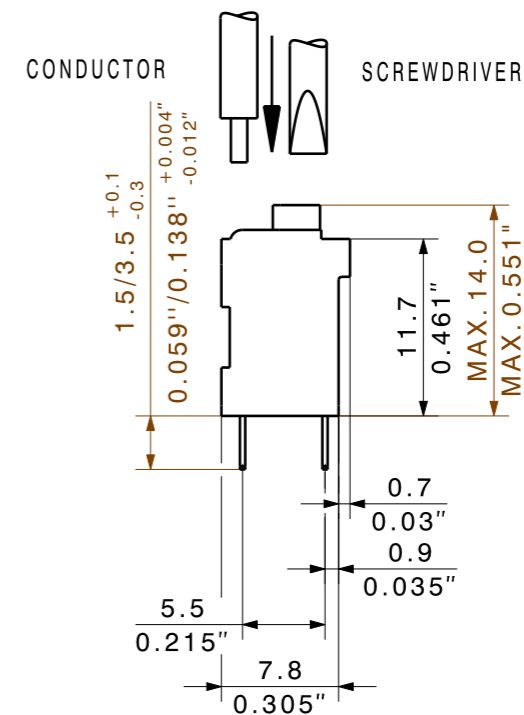

$MAX. \phi 3$
 $MAX. 0.118$

| | | |
|---|---------|-----------|
| 8 | 35,56 | 1,400 |
| 7 | 30,48 | 1,200 |
| 6 | 25,40 | 1,000 |
| 5 | 20,32 | 0,800 |
| 4 | 15,24 | 0,600 |
| 3 | 10,16 | 0,400 |
| 2 | 5,08 | 0,200 |
| n | L1 [mm] | L1 [Inch] |

For the mounting on PCBs, it should be noted that the rated data relates only to the PCB components alone. The necessary creepage and clearance paths must be observed in the relevant equipment standards in accordance with IEC 664 / VDE 0110. The current-carrying capacity and pitch tolerance is to be determined according to DIN IEC 326 part 3.

Weidmüller PCB components are rated in accordance with the DIN EN 61984 standard, and are valid for its field of application. If the components are used in accordance with the intended purpose, the components will meet all requirements with respect to the occurring of electrical, mechanical, thermic and corrosive stress.

| | | | | |
|-----------------------------|----------------|-------------------|---|--|
| | DIN ISO 2768-m | | Cat.no.: . | |
| | 98688/5 | 23.10.17 HELIS_MA | 00 | |
| | | | 3 34084 15 | |
| Modification | | | Drawing no. Issue no. | |
| Date Name | | | Sheet 04 of 07 sheets | |
| Drawn 22.06.2004 SEIDEL_T | | | LSF-SMT .../.../180...TU LEITERPLATTENKLEMME PCB TERMINAL | |
| Responsible KRUG_M | | | | |
| Checked 01.11.2017 HELIS_MA | | | | |
| Scale: 5/1 | | | Product file: LSF-SMT | |
| Supersedes: . | | | Approved HECKERT_M 7358 | |

Wave Solder Profile

Recommended wave soldering profiles

Weidmüller Interface GmbH & Co. KG

Klingenbergstraße 16

D-32758 Detmold

Germany

Fon: +49 5231 14-0

Fax: +49 5231 14-292083

www.weidmueller.com

Single Wave:

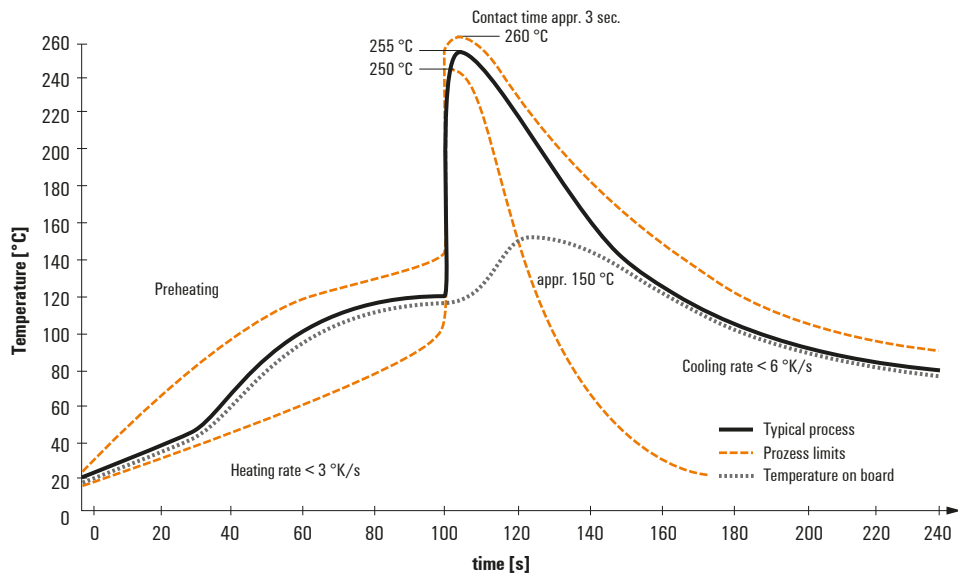

Double Wave:

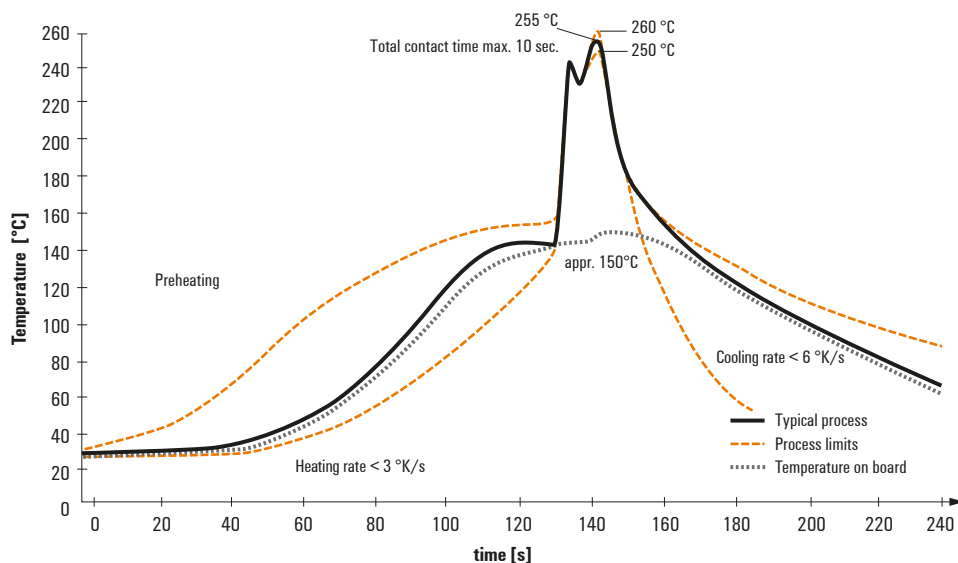

Wave soldering profiles

Wired connection elements should be processed in accordance with the DIN EN 61760-1 standard. We have included two recommendations for practical wave soldering profiles, with which Weidmüller PCB terminals and connectors are qualified.

When choosing a suitable profile for your application, the following factors also need to be considered:

- PCB thickness
- Proportion of Cu in the layers
- Single/double-sided assembly
- Product range
- Heating and cooling rates

The single and double wave profiles each indicate the recommended operating range, including the maximum soldering temperature of 260°C. In practice, the maximum soldering temperature is quite often well below the above maximum profile.

We reserve the right to make technical changes.

Reflow Solder Profile

Recommended reflow soldering profile

Weidmüller Interface GmbH & Co. KG

Klingenbergstraße 16

D-32758 Detmold

Germany

Fon: +49 5231 14-0

Fax: +49 5231 14-292083

www.weidmueller.com

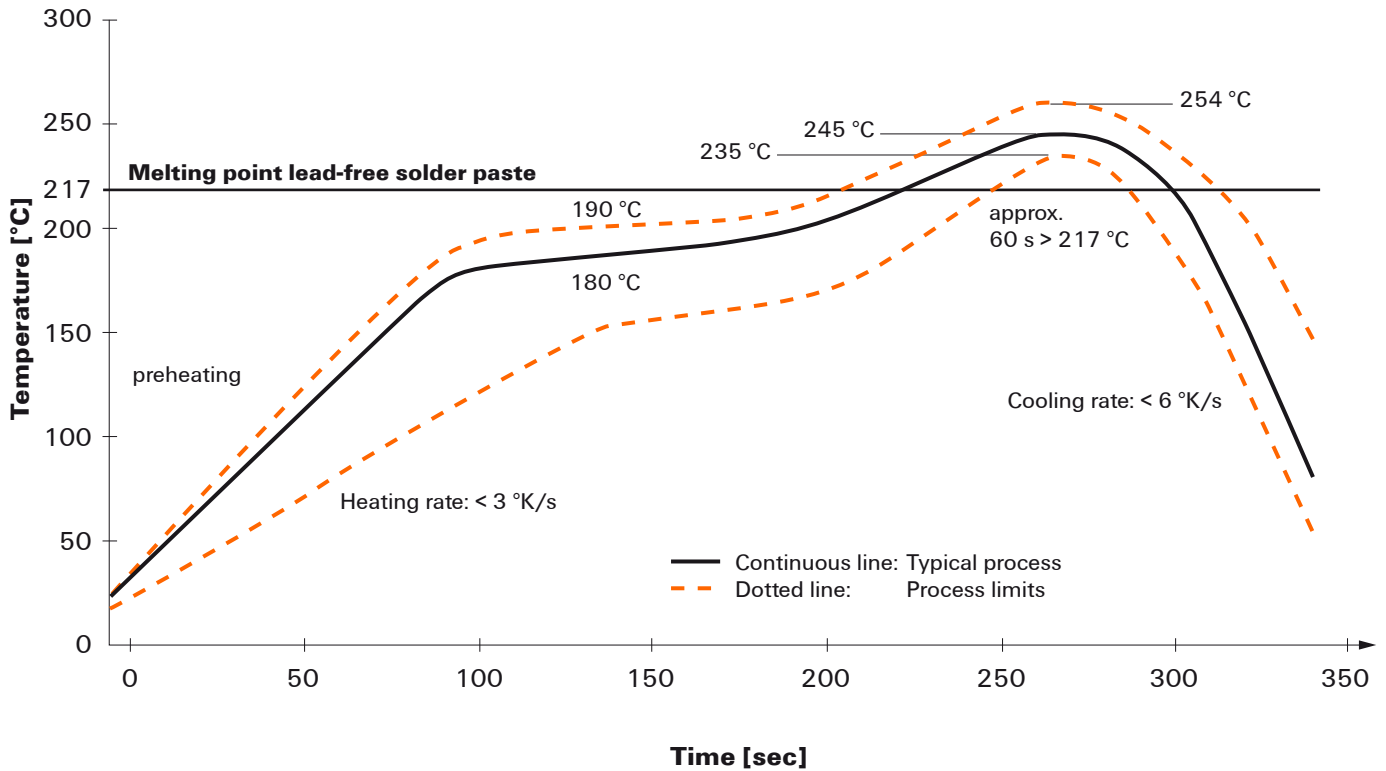

Reflow soldering profile

The perfect soldering profile for SMT Surface Mount Technology is one the most exiting question in SMT production. But there are more than one correct answer: The diagram of temperature-on-time is related to processing features of solder paste and to maximum load of components.

We have to consider the following parameters:

- Time for pre heating
- Maximum temperature
- Time above melting point
- Time for cooling
- Maximum heating rate
- Maximum cooling rate

We recommend a typical solder profile with associated process limits. With preheating components and board are prepared smoothly for the solder phase. Heating rate is typically $\leq +3\text{K/s}$. In parallel the solder paste is ‚activated‘. The time above melting point of 217°C the paste gets liquid and components and boards begin to connect. The maximum temperature of 245°C to 254°C should stay between 10 and 40 seconds. In the cooling phase at $\geq -6\text{K/s}$ solder is cured. Board and components cool down while avoiding cold cracks.

We reserve the right to make technical changes.



SCATTERGOOD & JOHNSON LTD

ELECTRICAL ENGINEERING & FLUID CONTROL DISTRIBUTORS

Est.1899

At Scattergood & Johnson Ltd, we pride ourselves on being a technical distributor to specialist industries.

Working with a range of quality product suppliers across a number of specialist markets, we are not your average 'box shifter' - we are your technical and supply chain partner.

We fully support every product we sell - for free! Our internal team and external sales engineers can answer any product or application question, no matter the complexity.

Backing up this technical ability is a range of 50,000+ products available from stock for nationwide next day delivery (same day if required!), or you can collect what you need from any of our trade counters around the UK.

Select your specialist interest below to learn more about how we can help.



Online, In Branch and On the Road - Scattergood & Johnson Ltd, there when you need us.

www.scatts.co.uk