

# FLH 250 | FLH 400 FAN HEATER 250–400 W

The FLH series of fan heaters consists of two versions with heating performance ratings of 250 and 400 Watts. This type of heating is ideal for use in larger electrical enclosures. It has an integrated fan that assists the natural convection and thus provides for fast and even distribution of the heat in the control cabinet.



PRODUCT	FLH 250	FLH 400	
ARTICLE NO.	17025010007	17040010007	UNIT
ARTICLE NO. with 2 <sup>nd</sup> protective grille	17025010107	17040010107	

#### DATA

Heating performance (Ta = +20 °C)	250	400	W
Rated voltage <sup>1</sup> ±10 %	AC 50   60 Hz		V
	230		
Functional range	207–258 V AC 50   60 Hz		
Max. starting current	1.1	1.8	A
Max. surface temperature	70	85	°C
Operating temperature	–40 ... +70		
System of protection for intended purpose of use	IP 20		
Protection class	I		
Device construction	aluminium profile, brightly anodised		
Type of mounting	snap fastening for 35 mm profile bars according to EN 60715		
Type of connection	plug terminal connector		
Weight	1035	1200	g

ACCESSORIES	ARTICLE NUMBER
Thermostat	17111000000
Hygrostat	17207000000
Internal enclosure fan	18110000000

For additional models, options and voltages visit [www.pfanenberg.com](http://www.pfanenberg.com) or contact us directly.

<sup>1</sup> other voltages available on request



## Dimensions

mm	FLH 250	FLH 400
<b>X</b>	85	85
<b>Y1</b>	186.5	226.5
<b>Y2</b>	90	110
<b>Y3</b>	65	65
<b>Z</b>	104	104

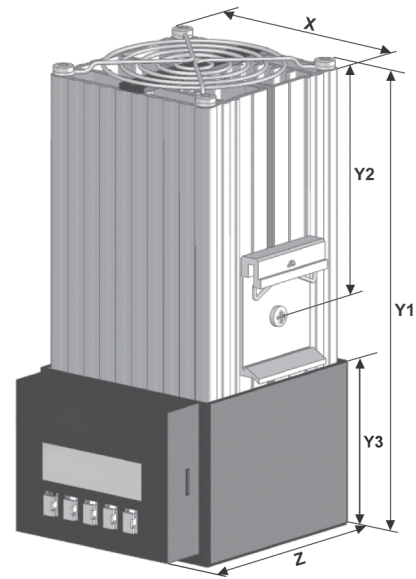



# SCATTERGOOD & JOHNSON LTD

ELECTRICAL ENGINEERING & FLUID CONTROL DISTRIBUTORS

Est.1899

At Scattergood & Johnson Ltd, we pride ourselves on being a technical distributor to specialist industries.

Working with a range of quality product suppliers across a number of specialist markets, we are not your average 'box shifter' - we are your technical and supply chain partner.

We fully support every product we sell - for free! Our internal team and external sales engineers can answer any product or application question, no matter the complexity.

Backing up this technical ability is a range of 50,000+ products available from stock for nationwide next day delivery (same day if required!), or you can collect what you need from any of our trade counters around the UK.

Select your specialist interest below to learn more about how we can help.



Online, In Branch and On the Road - Scattergood & Johnson Ltd, there when you need us.

# [www.scatts.co.uk](http://www.scatts.co.uk)