

FLH-T

FAN HEATER WITH INTEGRATED THERMOSTAT 250–1000 W

Pfannenberger heater line with integrated thermostat. This line has been specifically developed for demanding environments, especially wind turbines and for use in the telecommunications sector.

- all tests were performed according to European Norms, EN 60068-2-6 / 60068-2-27 / 60068-2-29 Railway applications - Rolling stock equipment - Shock and vibration tests and therefore are unique to the industry
- can be used under extreme conditions (- 40 °C...+ 70 °C)
- fan design with ball bearing: guaranteed long service life
- voltage range: 230 V / 115 V / 50/60 Hz



PRODUCT		FLH-T 250	FLH-T 400	FLH-T 600	FLH-T 800	FLH-T 1000	
ARTICLE NO.	230 V	17025310007	17040310007	17060310007	17080310007	17099310007	Unit
ARTICLE NO.	115 V	17025315007	17040315007	17060315007	17080315007	17099315007	

DATA

Heating performance (Ta = +20 °C)		250	400	600	800	1000	W
Rated voltage ±10 %		AC 50 60 Hz					
		230					V
Functional range		104–127 V or 207–258 V AC 50 60 Hz					
Max. starting current		0.7	2.6	3.4	4.3	5.2	A
Bearing type		ball bearing					
Service life L ₁₀ (+ 25 °C)		52500					h
Switching temperature difference		< 7					K
Switching point tolerance		± 4					
Temperature setting range		-20 ... +40					°C
Operating temperature		-40 ... +70					
Volumetric air flow	50 Hz	160					m ³ /h
	60 Hz	180					
System of protection for intended purpose of use		IP 20					
Protection class		II (double insulation)					
Device construction		plastic UL 94V-0, black					
Type of mounting		4 x M5 screws (not included)					
Type of connection		2-pole terminal strip					
Weight		1.0	1.1	1.2	1.4	kg	

ACCESSORIES	ARTICLE NUMBER
Hygrostat	17207000000
Internal enclosure fan	18110000000

For additional models, options and voltages visit www.pfannenberger.com or contact us directly.



Dimensions

mm	FLH-T
X	150
X1	138
X2	6
X3	5.4
Y	100
Z	164
Z1	100
Z2	13.3
Z3	5

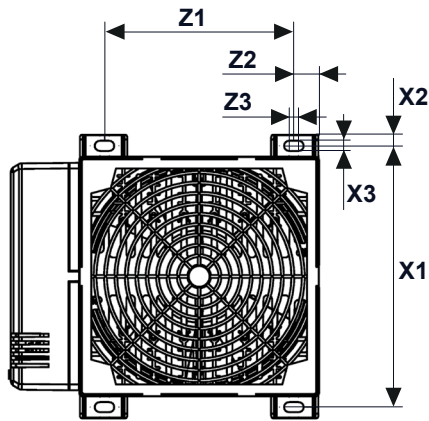
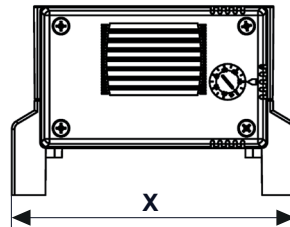
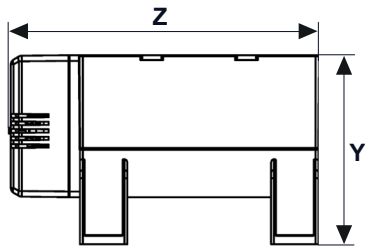
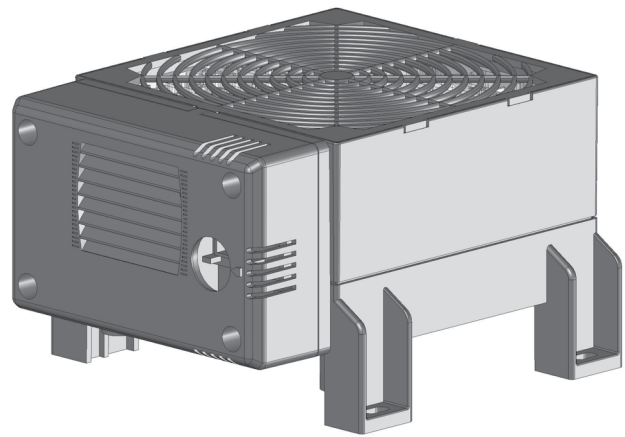



SCATTERGOOD & JOHNSON LTD

ELECTRICAL ENGINEERING & FLUID CONTROL DISTRIBUTORS

Est.1899

At Scattergood & Johnson Ltd, we pride ourselves on being a technical distributor to specialist industries.

Working with a range of quality product suppliers across a number of specialist markets, we are not your average 'box shifter' - we are your technical and supply chain partner.

We fully support every product we sell - for free! Our internal team and external sales engineers can answer any product or application question, no matter the complexity.

Backing up this technical ability is a range of 50,000+ products available from stock for nationwide next day delivery (same day if required!), or you can collect what you need from any of our trade counters around the UK.

Select your specialist interest below to learn more about how we can help.



Online, In Branch and On the Road - Scattergood & Johnson Ltd, there when you need us.

www.scatts.co.uk