

FLZ 600 | FLZ 610 HYGROSTAT | HYGROSTAT-THERMOSTAT COMBINATION DEVICE

Hygrostats from the FLZ series switch on control cabinet heaters or filterfans when a preset relative humidity is exceeded. The relative humidity is kept above the dew point and the condensation of water on electrical components and the corrosion of unprotected sheet metal is prevented. The electronic combination device unites thermostat and hygrostat in one housing and, at the same time, monitors the relative humidity and the temperature independently of each other.



PRODUCT	FLZ 600	FLZ 610	
ARTICLE NO.	17207000000	17218100000	Unit

DATA

Device implementation		mechanical hygrostat	electronic hygrostat-thermostat combination device	
Rated voltage ±10%		N/A	AC 50/60 230	Hz V
Type of contact		changeover with spring contact	changeover/relay	
Switching difference		approx. 5 %	approx. 2 K ±1 K / approx. 4 % R.H. ±1 %	
Contact resistance		–	< 10	mΩ
Max. switching power value in brackets: inductive load at cos φ = 0.6	N.C.	24–230 V AC / 5 (0.2) A – min. 100 mA	240 V AC, 8 (3) A or 120 V AC, 8 (3) A	
	N.O.	24–230 V AC / 5 (0.2) A – min. 100 mA	24 V DC, 4 A	
	DC	50 V, 1 A 75 V, 0.5 A min. 100 mA	–	
Setting range		40–90		% R.H.
Operating temperature		0 ... +60	0 ... +60 –20 ... +60	°C
System of protection		IP 30	IP 20	
Probe type		polyamide belt	–	
Suitable for the operation of		fan and heater		
Operating display		–	LED	
Type of mounting		snap fastening for 35 mm profile bars according to EN 60715		
Type of connection		screw terminal for cable cross-section 0.5 to 2.5 mm ²		
Colour		RAL 7035		
Weight		55	85	g

ACCESSORIES	ARTICLE NUMBER
-------------	----------------

Hygrostat	17207000000
Internal enclosure fan	18110000000

For additional models, options and voltages visit www.pfanenberg.com or contact us directly.



Dimensions

mm	FLZ 600	FLZ 610
X	37	59
Y	60	80.5
Z	47	38

FLZ 600 **FLZ 610**

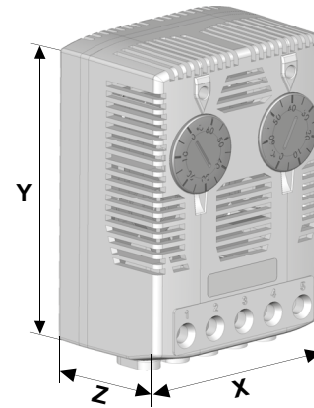
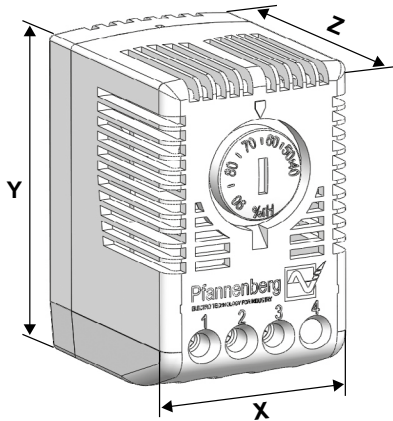

Schematics

FLZ 600

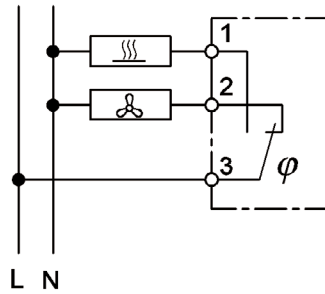

FLZ 610

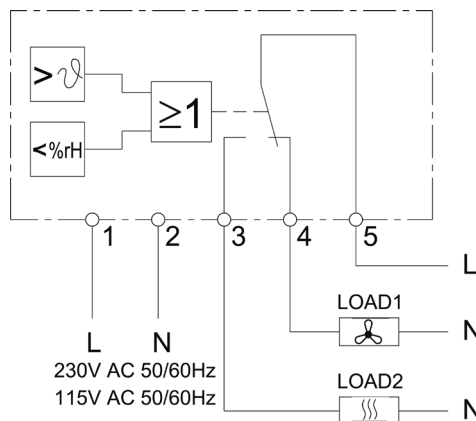



SCATTERGOOD & JOHNSON LTD

ELECTRICAL ENGINEERING & FLUID CONTROL DISTRIBUTORS

Est.1899

At Scattergood & Johnson Ltd, we pride ourselves on being a technical distributor to specialist industries.

Working with a range of quality product suppliers across a number of specialist markets, we are not your average 'box shifter' - we are your technical and supply chain partner.

We fully support every product we sell - for free! Our internal team and external sales engineers can answer any product or application question, no matter the complexity.

Backing up this technical ability is a range of 50,000+ products available from stock for nationwide next day delivery (same day if required!), or you can collect what you need from any of our trade counters around the UK.

Select your specialist interest below to learn more about how we can help.



Online, In Branch and On the Road - Scattergood & Johnson Ltd, there when you need us.

www.scatts.co.uk