

# LED MULTI FUNCTION LIGHT

## Quadro-LED Flex-3G/3D



- Designed for tough requirements under industrial conditions.
- Suitable for indoor and outdoor use.
- Suitable for use in potentially explosive areas in Zones 2 and 22.
- Extremely insensitive to shock and vibration.
- Maintenance-free service life exceeding 50,000 hrs.
- Internally and externally selectable operating mode as standard; one device for 4 different alarms:
  - continuous light
  - blinking light
  - flashing light
  - rotating light (non-wearing)
- 24 V AC/DC devices as standard with Soft Start Module.
- Can be operated directly via 24 V transistor PLC output, no additional relay control necessary.
- Inexpensive and flexible; wide range power supplies as standard.



protection system



impact-proof housing



operating temperature



warranty

PRODUCT	Quadro-LED Flex 3G/3D ATEX			
Rated voltage	115 V / 230 V		24 V	
	AC 50   60 Hz		AC 50   60 Hz / DC	
Operating range	AC	95–253 V		15–40 V
	DC			10–60 V
Current consumption in continuous light mode	60 mA		250 mA	
Explosion protection	II3G Ex nR II T5 X –20 °C ≤ Ta ≤ +55 °C II3G Ex nR II T6 X –20 °C ≤ Ta ≤ +50 °C II3D IP66 T 85°C X –20 °C ≤ Ta ≤ +55 °C			
Category (area of use)	3G (Zone 2), 3D (Zone 22)			
Conformity to standards	Guideline 94/9/EG (ATEX 100a)			
Testing body	Pfannenberg			
Special conditions	X: according to the requirements of prDIN EN 60 079-0, DIN EN 61241-0 (2007) and DIN EN 61241-1 (2005), the equipment is suitable for applications with a low degree of mechanical danger. It must therefore be ensured that the light is mounted with sufficient protection against impacts. A protective cage is not mandatory.			
Operating mode (internally and externally selectable)	continuous light	blinking light	flashing light	rotating all-round light
Light alternation frequency		1.5 Hz	1 Hz	2.5 Hz
Light source	LED; 8x 2 pieces (3 chip version)			
Light intensity (DIN 5037) <sup>1</sup>	9 cd			
Operating temperature	–20 °C ... +50 °C (T6) / –20 °C ... +55 °C (T5)			
Storage temperature	–40 °C ... +70 °C			
Relative humidity	100 %			
Protection system (EN 60529)	IP 66; mounting arbitrary			
Impact resistance (EN 50102)	IK08			
Protection class	II			
Duty cycle	100 %			
Service life of the light source	>50,000 hrs			
Material	lens	polycarbonate (PC)		
	housing	polycarbonate (PC), light grey RAL 7035		
Connecting terminals	cage clamp terminal 0.08–2.5 mm <sup>2</sup>			
Cable entry	2x M20 x 1.5 (1x blanking plug, 1x cable connection)			
Weight	500 g			

<sup>1</sup> with a clear lens

**DIMENSIONS**

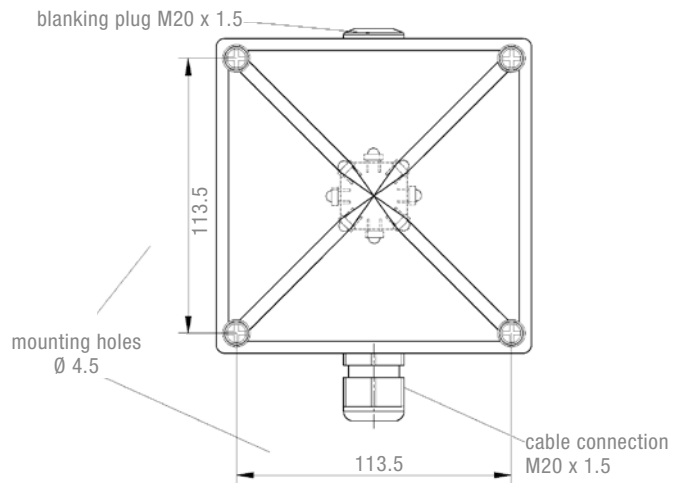
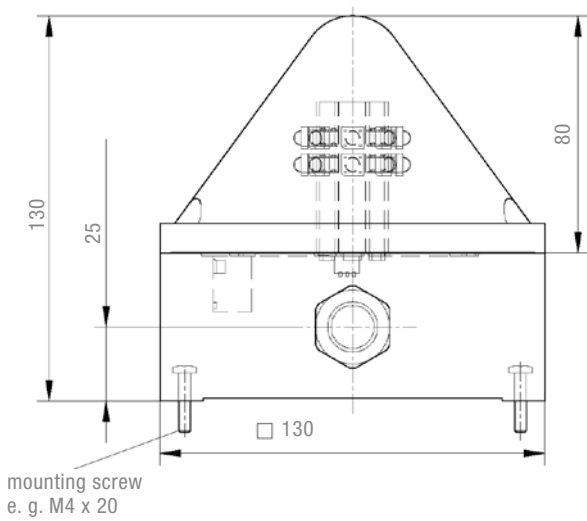

**OPERATING MODES**

S1			Selection via internal DIP switch	
1	2	3		
OFF	OFF	OFF	OFF	
OFF	OFF	ON	all-round light	2.5 Hz
OFF	ON	OFF	continuous light	
OFF	ON	ON	blinking light	1.5 Hz
ON	OFF	OFF	flashing light	1 Hz
ON	OFF	ON	all-round light	2.5 Hz
ON	ON	OFF	continuous light	
ON	ON	ON	blinking light	1.5 Hz

S1 - 1	X1 - 1	2	3	4	Selection via external control	
(S1-2 = OFF, S1-3 = OFF)						
OFF	-/N	+/L			OFF (standby)	
OFF	-/N	+/L		+/L	all-round light	2.5 Hz
OFF	-/N	+/L	+/L		continuous light	
OFF	-/N	+/L	+/L	+/L	blinking light	1.5 Hz
ON	-/N	+/L			flashing light	1 Hz
ON	-/N	+/L		+/L	all-round light	2.5 Hz
ON	-/N	+/L	+/L		continuous light	
ON	-/N	+/L	+/L	+/L	blinking light	1.5 Hz

ARTICLE NO.	Quadro-LED Flex 3G/3D ATEX	
Lens colour	115 V / 230 V AC	24 V AC/DC
●	21104643009	21104633009
●	21104644009	21104634009
●	21104645009	21104635009

Article numbers for other colours and voltages on request.

CONNECTION DIAGRAM

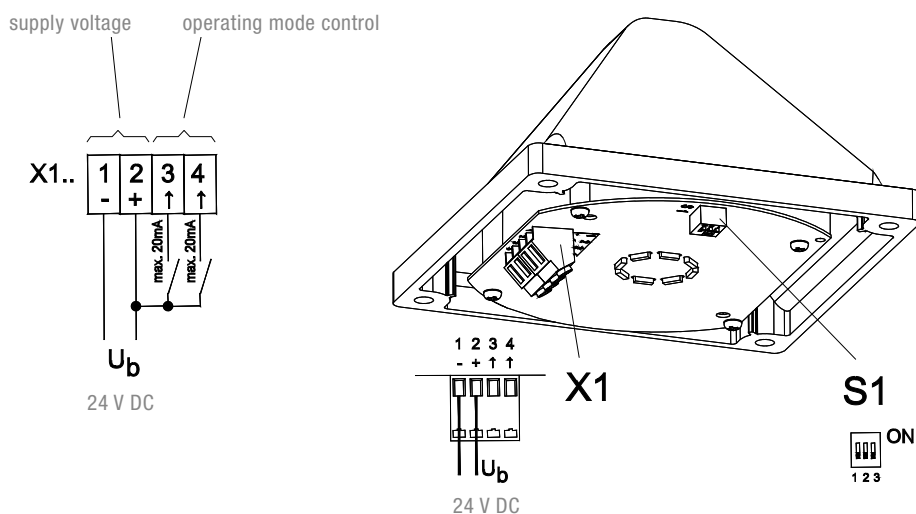

MANUFACTURER'S DECLARATION

We hereby declare that the explosion-protected means of alarm with the type designation **Quadro-LED Flex 3G/3D** has been developed and manufactured in accordance with the requirements as per EN 60079.

**This declaration is based on compliance with the following regulations and standards:**

- DIN EN 60079-0      Electrical equipment for areas at risk of gas explosions – Part 0: General requirements
- DIN EN 60079-15    Electrical equipment for areas at risk of explosions – Part 15: type of protection type “n”
- DIN EN 61241-0      Electrical equipment for use in areas with combustible dust – General requirements
- DIN EN 61241-1      Electrical equipment for use in areas with combustible dust – protection by enclosure “tD”
- DIN EN 60598-1      Lights – Part 1: General requirements and tests
- DIN EN 60947-1      Low-voltage switchgear – Part 1: General specifications
- DIN EN 60529          Types of protection by enclosure (IP code)
- DIN EN 50102          Types of protection by enclosure for electrical equipment against external mechanical stresses (IK code)
- DIN EN 61000-6-2    Electromagnetic compatibility (EMC) – Part 6-2: Generic standards, noise immunity for industrial areas
- DIN EN 61000-6-3    Electromagnetic compatibility (EMC) – Part 6-3: Generic standards, interference emission for residential areas, business and commercial areas as well as small companies
- DIN EN 981            Machine safety – System of acoustic and visual alarm signals and information signals
- ISO 11429             System of acoustic and visual alarm signals and information signals
- UVV-BGV A3(VBG4)    Electrical plants and equipment
- GSGV                    German Appliance Safety Act

The Quadro-LED Flex 3G/3D multifunction lights are approved for use in potentially explosive areas in Zones 2 and 22 as per 94/9/EU.



# SCATTERGOOD & JOHNSON LTD

ELECTRICAL ENGINEERING & FLUID CONTROL DISTRIBUTORS

Est.1899

At Scattergood & Johnson Ltd, we pride ourselves on being a technical distributor to specialist industries.

Working with a range of quality product suppliers across a number of specialist markets, we are not your average 'box shifter' - we are your technical and supply chain partner.

We fully support every product we sell - for free! Our internal team and external sales engineers can answer any product or application question, no matter the complexity.

Backing up this technical ability is a range of 50,000+ products available from stock for nationwide next day delivery (same day if required!), or you can collect what you need from any of our trade counters around the UK.

Select your specialist interest below to learn more about how we can help.



Online, In Branch and On the Road - Scattergood & Johnson Ltd, there when you need us.

# [www.scatts.co.uk](http://www.scatts.co.uk)